

Ordering information

Silent Tools™ Plus

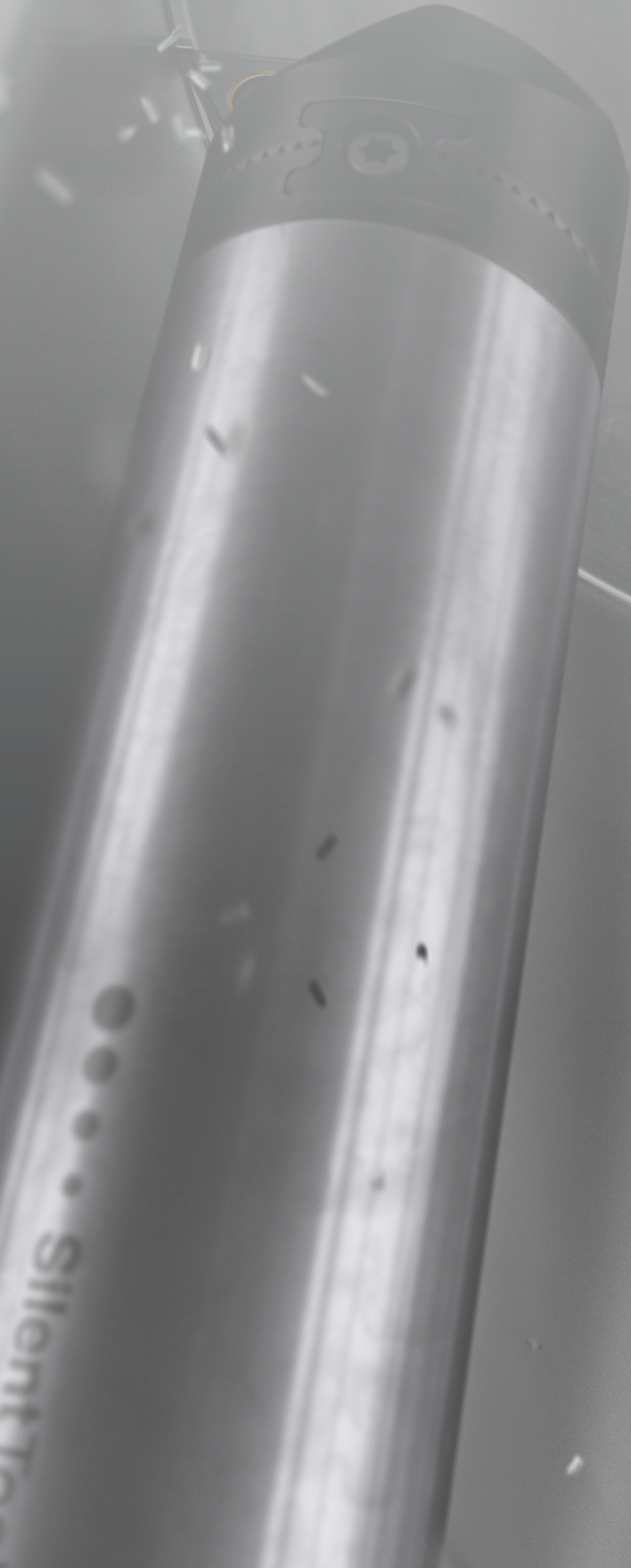



- 1 Introduction and availability**
- 2 Silent Tools Plus software**
- 3 Metric version**
- 4 Inch version**
- 5 Wedge Lock cutting heads**
- 6 Engineered solutions**

Connected turning solution

The sensor-equipped Silent Tools™ Plus damped adaptors increase process security in internal turning with long overhang. The solution gives you access to information about what's happening inside your component, making process improvements possible.

The product kit includes necessary cables, batteries, electronic unit, charger and wall charging adaptor. The Windows 10 tablet needed to access the Silent Tools Plus dashboard is not included.

Before starting to use the solution, you will need to activate your license. Documentation of how to activate your license and get started is delivered together with the tool. The same instruction can also be found on the Sandvik Coromant web.

Solution availability

Silent Tools Plus is available in selected markets within the European union, Japan and North America.

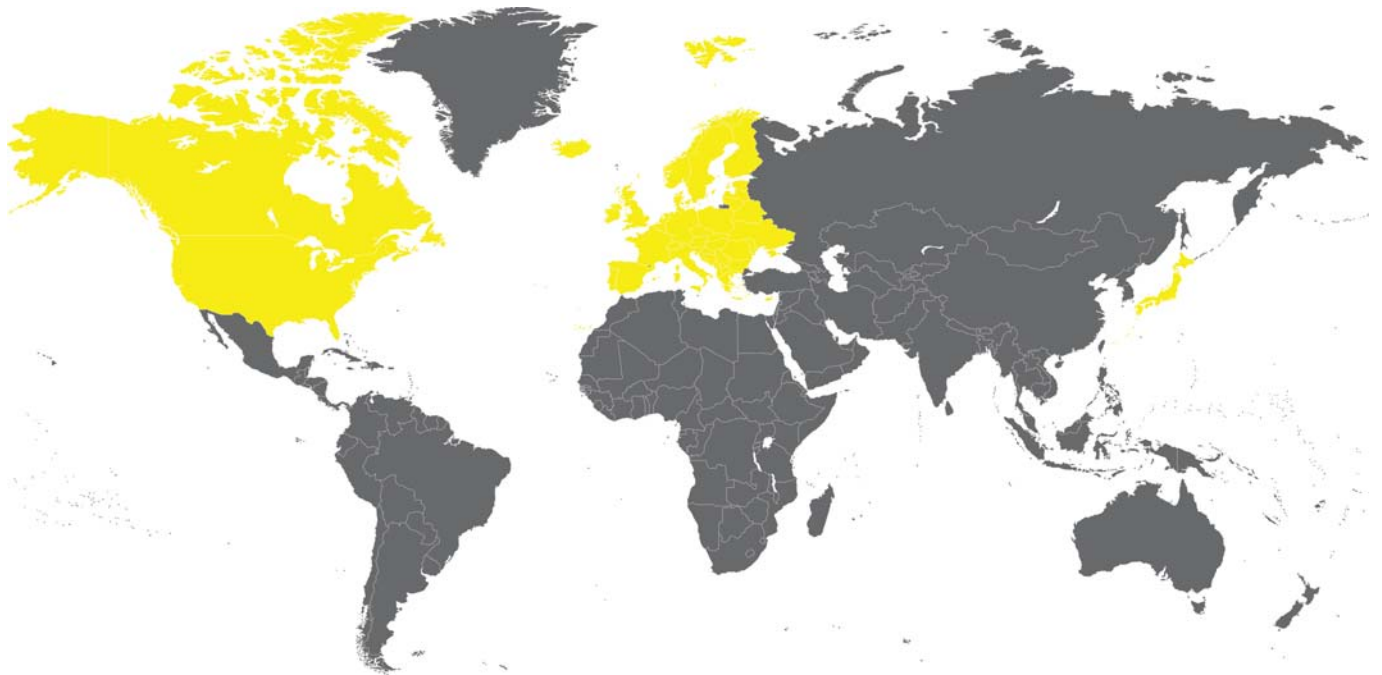

For more information, visit www.sandvik.coromant.com/silenttoolsplus

Silent Tools™ Plus



Silent Tools Plus software

The Silent Tools Plus software provides the operator with a completely new insight into the long overhang turning process. Having new “eyes and ears” inside the process gives operator confidence, and aids rapid, data-driven decision making before problems are allowed to escalate.

Knowing your process provides the route to process and stability improvements, reducing scrap and re-work while increasing productivity and tool utilization.

The software can be run on any Windows 10 device with Bluetooth connectivity.

To get started, follow the quick start guide found online at: www.sandvik.coromant.com/silenttoolsplus



Software features

	Silver Requires standard Silent Tools™ Plus damped adaptor	Gold In development, coming soon	Platinum Requires strain gauge equipped Silent Tools™ Plus damped adaptor	Diamond In development, coming soon
Operator training and support 24 hours on weekdays	✓		✓	
Software updates and new features	✓		✓	
Center height setting	✓		✓	
Real-time data visualization - Temperature, In-cut detection.	✓		✓	
Real-time data visualization - Surface toughness and vibration	✓		✓	
Real-time data visualization - Load and deflection			✓	
Ordering code	STS4-ST-SS12-01 (Yearly license)		STS4-ST-PS12-01 (Yearly license)	

Please note:

Software and adaptor can be used offline for periods of up to two months at a time before an online verification is needed.

Software and firmware updates are released regularly. It is recommended to always use the latest versions.

Internet access is required during software activation, online verification and when updating the software.

Silent Tools™ Plus

Metric version



ENG

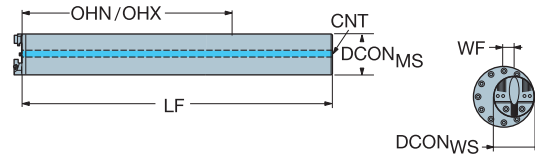

							Dimensions, mm						
CZC _{MS}	CZC _{WS}	OHN	OHX	CNSC	CXSC	Ordering code	DCON _{MS}	DCON _{WS}	LF	WF	CNT	BAR	KG
60	40	600	600	1	1	TA60D-CY60B810W4R/LB	60	40	810	10	G1/8	150	15
80	40	800	800	1	1	TA60D-CY80B1090W4R/LB	80	40	1090	20	G1/8	150	40
100	40	1000	1000	1	1	TA60D-CY100B1410W4R/LB	100	40	1410	30	G1/8	150	80

The ordering codes above are kits containing all the hardware you will need, but when ordering a Silent Tools Plus adaptor kit, you also need to order a service pack.

Service pack ordering code:
STS4-ST-SS12-01 (Yearly license)

Spare parts

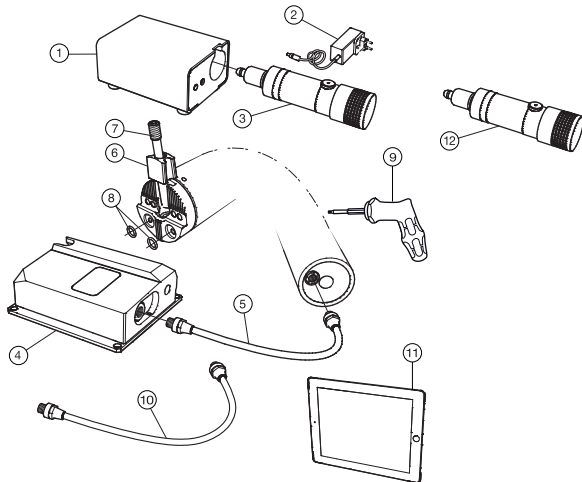

Spare parts								Included parts	Accessories			
1	2	3	4	5	6	7	8	9	10	11	12	
Battery charger	Power supply charger	Battery (2 batteries/KIT)	Electronic unit (1 output)	Cable (300 mm)	Wedge	Screw	O-rings	Torque wrench	Cable (500 mm)	Windows tablet	Cover plug	
7120 110-01	7110 010-02	7130 110-01	7210 110-01	7310 110-01	5431 015-01	5516 014-09	5641 005-153	5680 100-10	7310 110-02	7410 010-01	5645 060-01	

Silent Tools™ Plus

Inch version

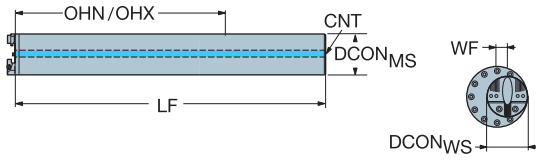

●●● SilentTools®

							Dimensions, inch						
CZC _{MS}	CZC _{WS}	OHN	OHX	CNSC	CXSC	Ordering code	DCON _{MS}	DCON _{WS}	LF	WF	CNT	PSI	LBS
2 1/2	40mm	21.500	21.500	1	1	TA60D-CYA40B810W4R/LB	2.500	40mm	31.890	.463	G1/8	2175	33
3	40mm	30.000	30.000	1	1	TA60D-CYA48B1090W4R/LB	3.000	40mm	42.913	.713	G1/8	2175	88
4	40mm	40.000	40.000	1	1	TA60D-CYA64B1410W4R/LB	4.000	40mm	55.512	1.213	G1/8	2175	176

The ordering codes above are kits containing all the hardware you will need, but when ordering a Silent Tools Plus adaptor kit, you also need to order a service pack.

Service pack ordering code:
STS4-ST-SS12-01 (Yearly license)

Spare parts

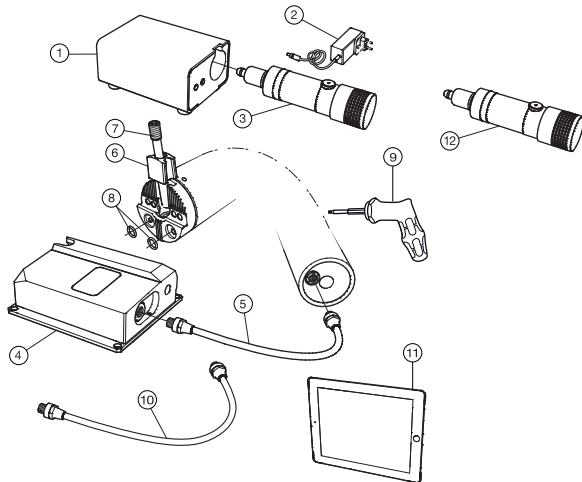

Spare parts								Included parts	Accessories			
1	2	3	4	5	6	7	8	9	10	11	12	
Battery charger	Power supply charger	Battery (2 batteries/KIT)	Electronic unit (1 output)	Cable (300 mm)	Wedge	Screw	O-rings	Torque wrench	Cable (500 mm)	Windows tablet	Cover plug	
7120 110-01	7110 010-02	7130 110-01	7210 110-01	7310 110-01	5431 015-01	5516 014-09	5641 005-153	5680 100-10	7310 110-02	7410 010-01	5645 060-01	

Silent Tools™ Plus

Wedge Lock cutting heads



ENG

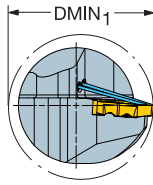

		Dimensions, mm, inch						
	DMIN ₁	Ordering code	DCON	LF	WF	KAPR	MIID	
	50.0	TITR-W4R/L-D13U-27A	40	29	27.0	93.0°	TR-DC 13 08	
	1.969		1.575	1.142	1.063			
		Dimensions, mm, inch						
	DMIN ₁	Ordering code	DCON	LF	WF	KAPR	MIID	
	50.0	TIP0-W4R/L-C12L-27A	40	31.0	27.0	95.0°	CNMG 12 04 08	
	1.969		1.575	1.220	1.063			
	50.0	TI07-W4R/L-C09L-27A	40	28.0	27.0	95.0°	CCMT 09 T3 08	
	1.969		1.575	1.102	1.063			
		Dimensions, mm, inch						
	DMIN ₁	Ordering code	DCON	LF	WF	KAPR	MIID	
	50.0	TIP0-W4R/L-D15U-27A	40	30.0	27.0	93.0°	DNMG 15 04 08	
	1.969		1.575	1.181	1.063			
		Dimensions, mm, inch						
	DMIN ₁	Ordering code	DCON	LF	WF	KAPR	MIID	
	50	TITR-W4R/L-V13U-27A	40	28	27	93°	TR-VB1308	
	1.969		1.575	1.102	1.063			
		Dimensions, mm, inch						
	DMIN ₁	Ordering code	DCON	LF	LPR	WF	KAPR	MIID
	50.0	TITR-W4R/L-D13UX27A	40	18.0	37.5	27.0	93.0°	TR-DC 13 08
	1.969		1.575	.709	1.476	1.063		
		Dimensions, mm, inch						
	DMIN ₁	Ordering code	DCON	LF	LPR	WF	KAPR	MIID
	50	TITR-W4R/L-D13X-27A	40	23	30	27	62.5°	TR-DC1308
	1.969		1.575	.906	1.181	1.063		

Silent Tools™ Plus

Wedge Lock cutting heads

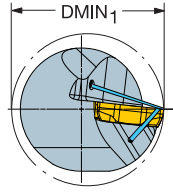

	DMIN ₁	Ordering code	Dimensions, mm, inch				MIID
			DCON	LF	WF	KAPR	
	50.0	TICP-W4R/L-A1130-27C	40	35.0	27.0	30°	CP-A1108
	1.969			1.575	1.378	1.063	
	50.0	TICP-W4R/L-B1125-27B	40	40.0	27.0	25°	CP-B1108
	1.969			1.575	1.575	1.063	
	50.0	TICP-W4R/L-B1125X27B	40	16.0	27.0	25°	CP-B1108
	1.969		1.575	.630	1.063		

When ordering a Silent Tools Plus adaptor kit, you need to order a service pack.

Service pack ordering code for engineered products:
STS4-ST-PS12-01 (Yearly license)

Diameter (mm)	Overhang (xD)				
	8	10	12	14	16
60		Standard			N/A
80					
100			Engineered: Vibration- and load sensor		
120					
140			Engineered: Vibration sensor		
160					
Up to 300					

Spare parts

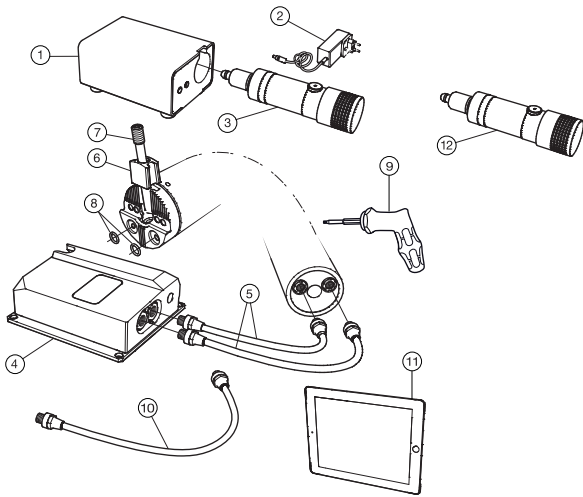

Spare parts								Included parts	Accessories			
1	2	3	4	5	6	7	8	9	10	11	12	
Battery charger	Power supply charger	Battery (2 batteries/KIT)	Electronic unit (2 outputs)	Cable (300 mm)	Wedge	Screw	O-rings	Torque wrench	Cable (500 mm)	Windows tablet	Cover plug	
7120 110-01	7110 010-02	7130 110-01	7210 110-02	7310 110-01	5431 015-01	5516 014-09	5641 005-153	5680 100-10	7310 110-02	7410 010-01	5645 060-01	

Head office:
AB Sandvik Coromant
SE-811 81 Sandviken, Sweden
E-mail: info.coromant@sandvik.com
www.sandvik.coromant.com

C-2900:162 en-GB © AB Sandvik Coromant 2019

