



weco **Compact chillers**



**Powerful and reliable.
Also for high ambient
temperatures.**

gwk

The smart approach to cooling. Energy-efficient. Competent.



**Improve parts
quality**

The chillers which can be either air- or water-cooled achieve a very high level of efficiency, reliably high operating safety and a long service life.



**Increase
productivity**

Even in fluctuating ambient temperatures, they guarantee absolutely stable production conditions, enabling tangible improvements in the production process.



**Lower
operating costs**

As gwk technology also handles energy extremely efficiently, your operating costs will be significantly reduced, which is good news for the environment, too.



**Produce
eco-friendly**

Environmentally friendly

As a specialist manufacturer of energy-saving technology we are taking responsibility for the environment. For many years we have led the way in developing equipment using environmentally friendly refrigerants. We are currently using the **Low-GWP R513A refrigerant** for our products.

Quality guaranteed

- Development and manufacture with experienced, qualified personnel
- A high degree of vertical integration provides a potential for flexibility
- Utilisation of proven brand components
- Test run of each machine before it is delivered
- Certified process procedures in accordance with DIN ISO EN 9001



Series weco 01 - 09

Air or water cooled up to 9 kW

The **gwk** compact water chillers, type **weco** 01 - 09 are aircooled units - size 07 and 09 are optionally available as water cooled version - that are piped and wired ready for connection. The sizes 01 and 03 are equipped with an assembly out of compressor, collector and condenser. The sizes 04 and 09 dispose of scroll compressors, separate condensers and fans as well as robust coaxial evaporators.

The tank volume of this machine series is rather large for the small capacities, so that the chillers are suitable for a wide range of application. The housing is designed as profile frame construction out of galvanized and varnished sheet steel with access from all four sides and steerable castors with two stop brakes. As standard the chillers are equipped with the **gwk** compact controller.

The most important data at a glance

Model	Nom. cooling capacity (kW)	Flow (m ³ /bar) ¹	Pressure (bar) ¹	Dimensions (L x W x H)	Weight (kg)
weco 01	1,3	3,6	3,8	675 x 735 x 1.000 mm	134
weco 03	2,9	3,6	3,8	675 x 735 x 1.000 mm	134
weco 04	4,2	4,2	4,9	675 x 835 x 1.250 mm	155
weco 07	7,4	4,2	4,9	675 x 835 x 1.250 mm	161
weco 09	9,1	4,2	4,9	675 x 835 x 1.250 mm	170

¹ Standard pump / Process pumps with higher capacities for weco Z series optionally

Subject to technical modification without notice!



Air and water cooled chillers

Series weco 15.1 - 300.1

Precise and compact

The overall technical design of the unit and the precise measurement and control technology enable a high temperature stability for every application. The high capacity together with a compact footprint enable the chiller to be sited even in re-stricted areas.

Fan and compressor concept

The fan concept reduces the noise level of the machines. By the use of high-performance compressors a very high degree of efficiency can be achieved. This results in low operating costs, high operating reliability and long service life of the chiller.

Set up, connect, ready

gwk compact water chillers are turnkey products. For end users this implies that the machine can be installed and connected without extensive assembly and that it is ready for immediate operation.

Available systems

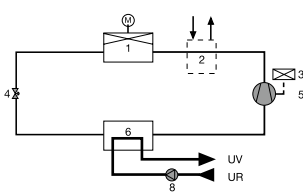
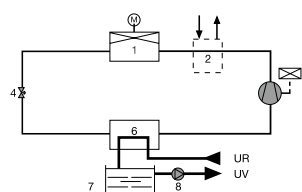
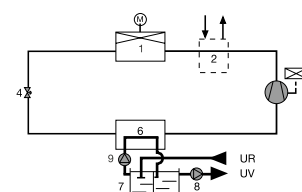
Basic Design (G)	Standard Design (B)	Central cooling plant (Z)
		
Pump type: Operating pump (optional)	Pump type: Operating pump	Pump type: Operating pump and evaporator pump
Without tank	Tank	Two-chamber tank
Applications: Open consumer circuits (existing reservoirs, external circuits and open cooling channels)	Applications: Direct connection to the consumer network with external sources of heat (mould cooling, hydraulic system cooling and individual processing machinery)	Applications: Simultaneous operation of several consumers at varying loads in the water network or at an increased return flow temperature

Legend: 1 = condenser / 2 = additional heating condenser* / 3 = temp. regulator / 4 = expansion valve / 5 = compressor / 6 = evaporator / 7 = water tank / 8 = process pump / 9 = evaporator pump / UV = to consumer / UR = from consumer / — = cold water circuit / — = refrigerant circuit / * = option



More options for exact temperature control

- Redundant/ Frequency-controlled operating pump
- Heat exchanger for heat recovery
- Flexible connection to an air duct system
- Outside installation kit
- Interfaces (serial interface, Profibus, Profinet, Ethercat and external contact interfaces)
- Special voltage
- Analogue fill level monitoring from external tank
- Axial fans operating in parallel with pressure-depending speed control and energy-efficient EC motors
- Moveable version

The most important data at a glance

Model	Nom. cooling capacity (kW)	Flow (m ³ /bar) ¹	Pressure (bar) ¹	Dimensions (L x W x H)	Weight air cooled (kg)	Weight water cooled (kg)
weco 15.1	15,5	4,2	4,7	1.000 x 1.630 x 2.000 mm	405	365
weco 24.1	24,0	6,3	4,9	1.000 x 1.630 x 2.000 mm	447	399
weco 35.1	36,0	6,3	4,9	1.000 x 1.630 x 2.000 mm	505	480
weco 48.1	48,5	15,1	5,0	1.000 x 2.450 x 2.000 mm	771	616
weco 59.1	60,5	15,1	5,0	1.000 x 2.450 x 2.000 mm	825	627
weco 71.1	72,0	15,1	5,0	1.000 x 2.450 x 2.000 mm	842	645
weco 85.1	96,0	22,0	5,4	1.220 x 3.100 x 2.150 mm	1.333	1.096
weco 100.1	118,5	22,0	5,4	1.220 x 3.100 x 2.150 mm	1.413	1.181
weco 120.1	136,5	30,0	5,5	1.220 x 3.100 x 2.150 mm	1.497	1.270
weco 145.1	146,0	53,5	4,5	1.750 x 3.825 x 2.420 mm	2.230	2.085
weco 170.1	172,0	53,5	4,5	1.750 x 3.825 x 2.420 mm	2.475	2.112
weco 190.1	197,5	53,5	4,5	1.750 x 3.825 x 2.420 mm	2.530	2.144
weco 230.1	230,0	53,5	4,5	1.750 x 4.625 x 2.420 mm	2.700	2.215
weco 250.1	257,0	84,0	4,5	1.750 x 4.625 x 2.420 mm	2.750	2.288
weco 300.1	321,0	84,0	4,5	1.750 x 4.625 x 2.420 mm	3.250	2.670

¹ Standard pump / Process pumps with higher capacities for weco Z series optionally

Subject to technical modification without notice!

Easy operation with touch screen

The proven **weco** series has been upgraded by the installation of a user-friendly touch-screen with new integrated functions. By a light touch on symbols on the start page useful functions like temperature control, pressure control etc. can be selected. Due to the modular controller design an expansion with a uniform operating concept is possible for all components. In order to supplement the operational safety, maintenance intervals and advice are indicated in clear text on the service page.

Temperature input and temperature display

The clear temperature trend display allows a process evaluation by visualisation of temperature differences for a freely selectable period of time.

The actual process evaluation is effected by the direct comparison of set and actual values with alphanumeric display and graphically by means of a thermometer. So with a simple glance it can be checked whether the requested temperature has been reached.

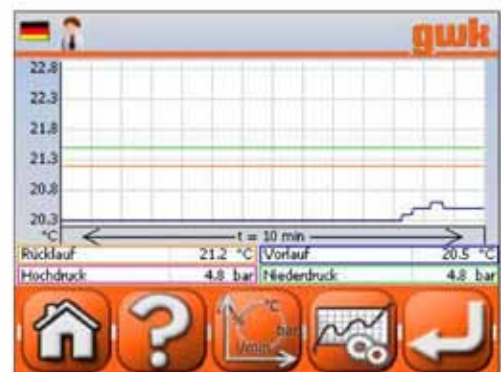
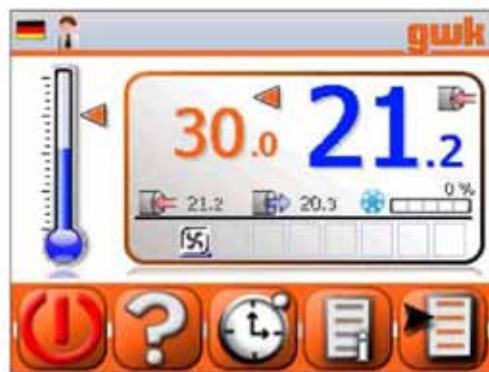

Pressure control

Visualisation of the pressure control allows a quick evaluation of the cooling circuit. By means of the option "service module" the temperatures in the cooling circuit can be displayed as well.

Tailor-made compact chillers

Various production processes, individual customer demands, national regulations and specific standards in different industrial sectors present a large number of requirements to the technical design of a water chiller. In close cooperation with customers of various industrial branches a new machine concept in modular design has been created over several decades.

One major strength of our company is our know-how in cooling technology by means of which we can convert thermal process requirements into constructive solutions in order to design tailor-made solutions for our customers with a high level of vertical integration.

Our experts will be pleased to advise you in the implementation of your requirements.

Design versions:

- Low-temperature chillers
- Chillers with integrated temperature control circuit
- Split type chillers
- Explosion-proof chillers
- Compact, high-performance chillers



Chillers with integrated temperature control circuit for temperatures of the medium from -30 °C to +90 °C



Customised low-temperature chiller

gwk Perfect Cooling and Temperature Control

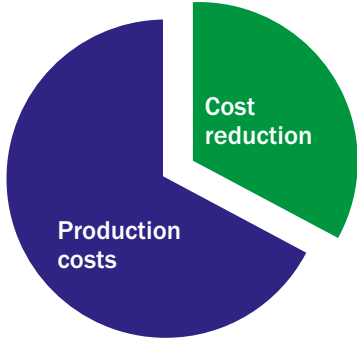

Increased productivity

In many areas of the industry, cooling and temperature control provides a great potential for increasing productivity and thus for lowering costs.

Many factors serve to improve productivity:

- Reduction of cooling time, therefore savings in required machine hours
- Improvement of product quality
- Increasing availability of production plants
- Decreasing running cost
- Reduction of maintenance cost



integrat 40/80/direct

Increase of productivity by means of specific and segmented mould temperature control.



gwk weco wd

Energy-efficient chillers with free cooling function and integrated temperature control circuits. Cooling and heating with one device only.



gwk teco c

The compact series with excellent price-performance ratio for the demanding plastics processor.



gwk container-plants

Highest flexibility and lowest expenses for planning, installation and relocation of a centralised cooling plant.



gwk protemp

High-performance temperature controller with increased flow rate and reduced energy consumption due to high quality stainless steel centrifugal pump.



gwk hermeticool hybrid

Innovative cooling system to decrease the running and maintenance cost in comparison to conventional cooling systems.



gwk teco

High process stability with customised temperature control solutions for all applications with high performance requirements up to 400 °C.



gwk container-plants

Highest flexibility and lowest expenses for planning, installation and relocation of a centralised cooling plant.



gwk teco cw

Most economic system to extract heat from consumers at very low temperatures by patented cold water temperature control.



gwk Service

Decreasing the maintenance cost and protection of company owned resources through professional execution of installation and maintenance works incl. cooling water treatment.



Member of the technotrans group

gwk Gesellschaft Wärme Kältetechnik mbH
 Scherl 10 · D-58540 Meinerzhagen
 Tel. +49 2354 7060-0 · Fax +49 2354 7060-150
 info@gwk.com · www.gwk.com

