

integrat evolution
integrat vario cs/wh/gt

Dynamic cavity temperature control
Cyclic mould heating and cooling



integrat vario cs/wh/gt and integrat ev

Cyclic and dynamic temperature control sy

Conventional temperature control methods have been around for almost fifty years. Operated within a cycle, they maintain a constant fluid temperature, any temperature changes can only be achieved within tight limits by means of continuous or discontinuous flow metering.

Dynamic mould temperature control is a temperature control method that allows temperature variations within the cycle, and is also known as “cyclical temperature control” or “variotherm temperature control”. While this method has been known for almost forty years, it has only undergone a dynamic development in the last few years. This is due to the increasingly exacting quality requirements of consumers, the use of polymer materials in new applications and fast technical advancement.

high cavity wall temperatures significantly improve mould filling and the reproduction of surface detail.

Compared to conventional methods, dynamic temperature control prevents joint lines, gloss variations and other surface defects are prevented by preheating the cavity wall with a heater and increasing the heat during the filling phase. As soon as the filling is completed, the cavity temperature is cooled down to a low temperature depending on the cycle.

When a temperature control system is selected it is important to mind that it matches exactly with the application and that the economic benefit justifies the technical efforts as well as the energy consumption.

All technological solutions available in the market are based on one basic insight:

| Technology | Heating medium |
|---|--|
| | Heating rate |
| | Max. temperature |
| Economic advantages | Energy consumption |
| | Investment costs |
| | Operating costs |
| | Mould modification |
| Desired effect | Applications |
| High-gloss surfaces of large parts | Frames, covers |
| High-gloss surfaces of small parts | Housings, mobile phone cases |
| High-gloss surfaces of foamed parts | Panels, covers |
| Concealing of weld-lines | Panels, covers |
| Concealing of numerous weld-lines, prevention of sink marks | Panels, covers |
| Functional surfaces | Medical technology |
| Moulding of micro structures | Plastic optics, displays |
| Adhesion optimization of hybrid parts | Metal-plastic composites |
| Start of thermosetting cross-linking reactions | Displays with scratch-resistant coatings |
| Adhesion optimization of multi-component injection moulding | Hard/hard and hard/soft composites |
| Extension of flow distance | Thin-walled articles, metal injection |

Evolution Systems are advancing

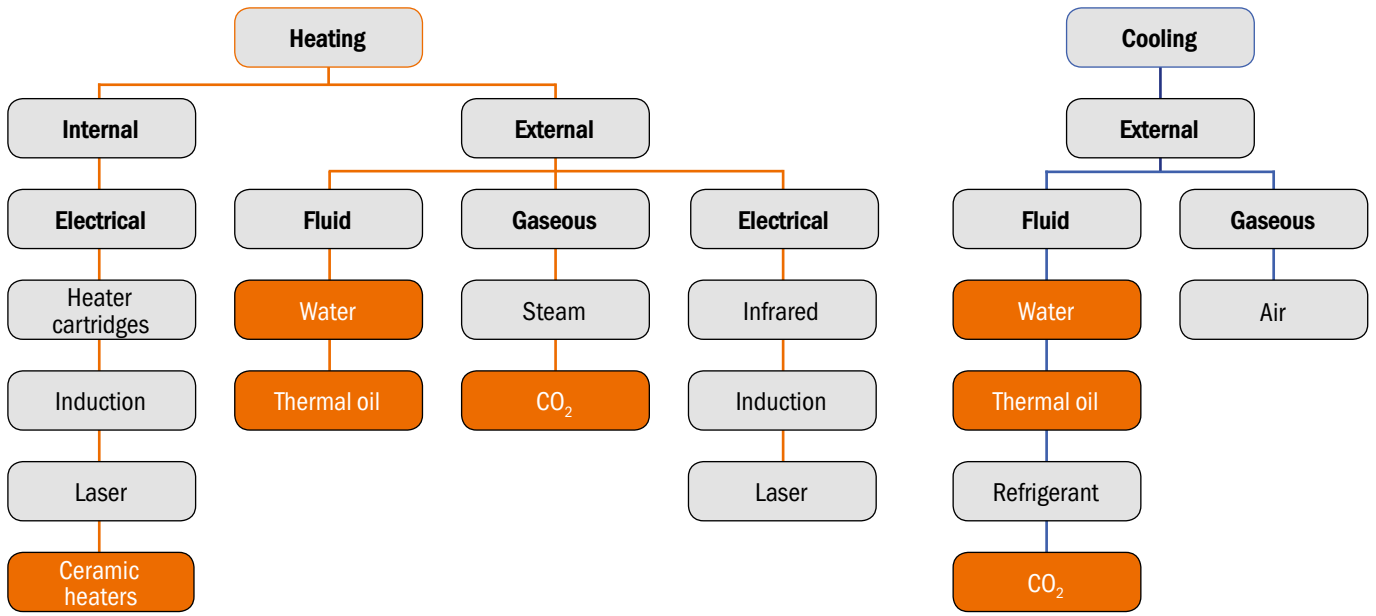

The variety of dynamic temperature control methods available in the market today is as wide as the range of applications they are used for.

| External heating processes | | | | | | | Internal heating processes | | |
|----------------------------|------------------|------------|-----------------|----------|-----------|----------|----------------------------|-----------|----------|
| Water | Heat carrier oil | Hot vapour | CO ₂ | Infrared | Induction | Laser | Ceramics | Induction | Laser |
| ★★★ | ★ | ★★★★★ | ★★★ | ★★★ | ★★★★★ | ★★★★★ | ★★★★★ | ★★★★★ | ★★★★★ |
| 200 °C | 300 °C | 200 °C | 250 °C | 200 °C | > 300 °C | > 300 °C | > 300 °C | > 300 °C | > 300 °C |
| ★★★ | ★★ | ★★ | ★★★ | ★★★ | ★★ | ★★★★ | ★★★★ | ★★★★ | ★★★★ |
| ★★★ | ★★★ | ★★ | ★★★ | ★★★★ | ★★ | ★★ | ★★★★ | ★★ | ★★ |
| ★★★ | ★★ | ★★ | ★★ | ★★★ | ★★ | ★★★★ | ★★★★ | ★★★★ | ★★★★ |
| ★★★ | ★★★ | ★★★ | ★★★ | ★★★ | ★★★★★ | ★ | ★★ | ★★ | ★★ |
| ★★★★★ | ★ | ★★★★★ | ★ | ★★★ | ★★★★★ | ★ | ★ | ★ | ★ |
| ★★★★★ | ★ | ★ | ★★★★★ | ★★★★★ | ★ | ★★★ | ★★★★★ | ★★★★★ | ★★★ |
| ★★★★★ | ★ | ★★★★★ | ★ | ★★★ | ★★★ | ★ | ★★★ | ★★★ | ★ |
| ★★★ | ★ | ★ | ★★★★★ | ★★★ | ★ | ★ | ★★★★★ | ★★★★★ | ★★★★★ |
| ★★★★★ | ★★★ | ★★★ | ★ | ★★★ | ★★★ | ★ | ★ | ★ | ★ |
| ★ | ★★★★★ | ★ | ★★★ | ★★★ | ★★★ | ★★★ | ★★★★★ | ★★★★★ | ★★★★★ |
| ★★★ | ★★★ | ★ | ★★★★★ | ★★★ | ★ | ★ | ★★★★★ | ★★★★★ | ★★★ |
| ★ | ★★★ | ★ | ★★★ | ★ | ★ | ★★★ | ★★★★★ | ★★★ | ★★★ |
| ★★★★★ | ★ | ★★★ | ★★★ | ★ | ★ | ★ | ★★★★★ | ★★★★★ | ★ |
| ★★★★★ | ★ | ★★★ | ★★★★★ | ★★★ | ★ | ★ | ★★★★★ | ★★★★★ | ★★★ |
| ★★★★ | ★ | ★★★ | ★★★★★ | ★ | ★★★ | ★ | ★★★★★ | ★★★★★ | ★★★ |

Process leading mould temperature control

Introduction and applications

Injection moulding is a cyclic process where a hot melt hits cooler cavity walls. This causes a thin material layer to „freeze“, thereby creating a thermal insulation, while the inner material of the injected part has to be cooled down to be stable enough to be ejected. This process has got a double impact. For one, due to the poor heat conductivity, for parts with increasing wall thickness the cooling time becomes the commanding factor of the total cycle time. For two the high demands placed on distortion, dimensional accuracy and, above all surface quality, have to be compensated for with an even higher cavity temperature which leads to a further increase in cycle time. Highly affected are all parts with high gloss surfaces and thick walled optical lenses with high quality demands, which cannot be produced eco-

nomically in large quantities with current manufacturing processes. A solution to this problem is the latest process with vario-thermic mould heating and dynamic cavity temperature control, which operates the heating and cooling intervals in accordance with the cycle times.

The active increase of the mould wall temperature during the injection phase leads to a better modelled surface and reduces internal stresses within the moulded parts. The following intensive cooling phase keeps the increase in cycle time within economically reasonable limits.

Conventional temperature control

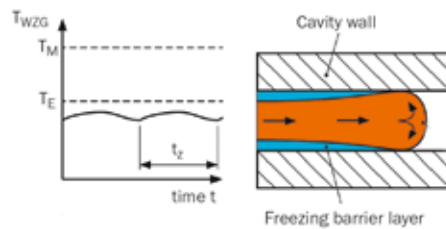

Highly dynamic cavity temperature control

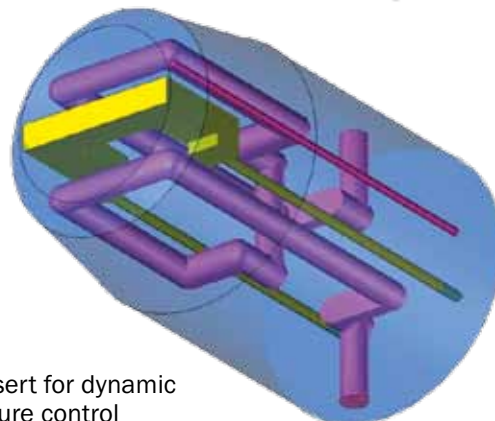
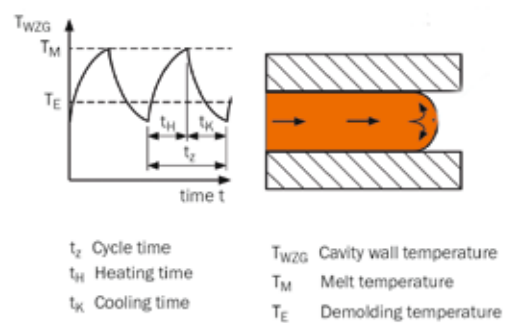

Mould insert for dynamic temperature control

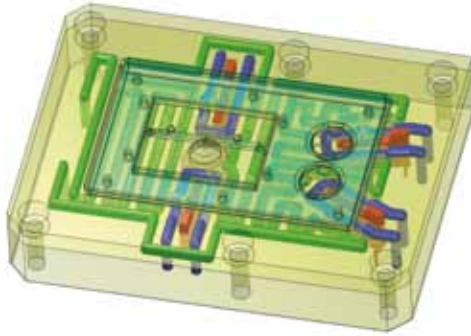
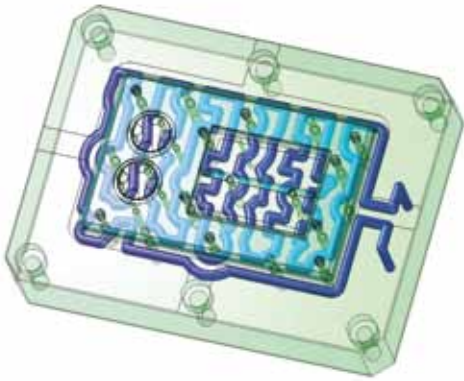

Visible weld-lines can be avoided by ceramic power heaters placed close to the cavity.



Conventional temperature control with visible weld-lines

Dynamic temperature control without visible weld-lines

Process leading mould temperature control

Multiple applications

Dynamic cavity temperature control has become an important criteria for the development of advanced, pioneering applications in automotive, aeronautical and medical engineering as well as other innovative segments of the industry.

The production of high-quality surfaces without typical flaws such as gloss imperfections or visible weld-lines is another tried and tested area of application for ceramic heaters. Excellent reproduction of surface details makes the production of functional surfaces cost-efficient. Removing visible weld-lines prior to coating used to be costly, as it required post-production polishing of the part after injection moulding. Integrated mould inserts now prevent the occurrence of these surface flaws. Special heating / cooling inserts with a ceramic temperature control system are used for part of the cavity or the entire cavity area is heated and cooled by fluids, depending on the application at hand. In-mould production of homo-

genous high-gloss surfaces obviates the need for post-production coating.

High-performance inserts with integrated ceramic heaters and contour-aligned cooling circuits are suitable for a variety of applications.

They are ideal for the production of ultrathin parts with formerly unattainable flow path / wall thickness ratios and for the cost-efficient production of thick-wall precision optical parts. Also, the strategic, individual thermal manipulation of components with completely different flow and cooling properties now allows formerly unrealistic material combinations.

Illustration of micro- and nano-structures

reflecting part



dynamic temperature control

non-reflecting part



conventional temperature control

Application possibilities

Optical parts

- Optimum surface quality
- Parts with big differences in wall thickness
- Modelling of nano structures (non-reflecting part)
- Scratch-proof coating of moulded parts directly inside the mould
- Reduction of double refraction



Medical products

- Moulding of micro- and nano-structures
- Functional surfaces; hydrophobic, hydrophilic, antibacterial, bio-adhesive articles
- Micro-optical components

Foamed components

- Improvement of surface quality
- Impact on cell structure

Back injection moulding of metal films

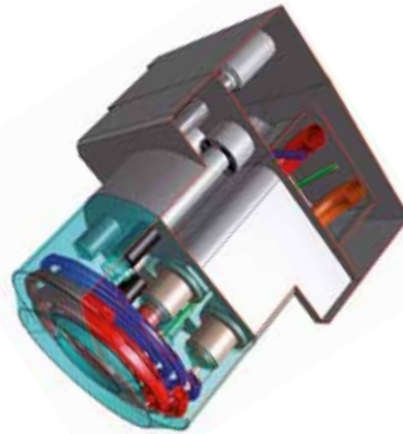
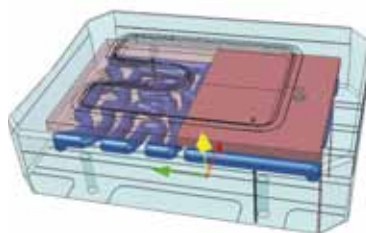

Thick-walled lens

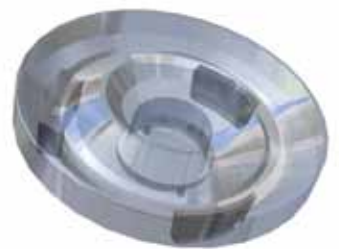

Technical parts

- Avoidance of weld-lines
- Reduction of dimensional stability and internal stresses
- Avoidance of holes and bubbles
- Stress release of material
- Impact on grade of crystallinity
- High dimensional and shape stability
- Brilliant surface quality and outline stability
- Reduction of start-up scrap
- Multi component injection moulding with various cavity wall temperatures

Thin wall parts

- Manufacture of components with very high flow way / wall thickness relation
- Reduction of injection pressure loss and injection pressure requirements
- Reduction of dumping and machine size

High-gloss surfaces without weld-lines





integrat evolution

Dynamic cavity temperature control with ceramic

While fluid-based solutions are largely used for integral temperature control of the production of high-quality surfaces, in-mould ceramic heaters are ideal for local heating or cooling of clearly defined mould segments. They are a reliable, fast and energy-efficient method of preventing visible joint lines. Electrically conductive ceramic materials are beneficial because of their pinpoint precision, immediate action and high capacity. Innovative production methods allow the combination of heat-conducting and thermally insulating layers. Close-to-cavity cooling achieves an even and fast cooling of specific mould segments after of the filling phase. The combination of both methods within one system can result in a more efficient, energy-saving mould temperature control with highly dynamic temperature variations.

The **integrat evolution** combines several modules. The **integrat 4D** technology is applied for the close-to-cavity arrangement of the temperature control channels in the mould. The circulation water for the mould temperature control is provided by **integrat 40** units. The energy-saving individual control of the water quantity per cooling channel for the cooling phase is taken over by the **integrat direct**. The **integrat process control** is responsible for the communication and control between the heating and cooling elements. The complete system is installed in a rack on a small footprint of only 60 x 60 cm. Energy and cooling water supply are realized via common central connections.



Reduce cycle time



Improve parts quality



Minimize reject rates



Reduce energy costs

mic power heaters

Ideal applications are high-gloss surfaces in the automotive and consumer goods sector as well as in telecommunications. Also thick-walled moulded parts for optical applications can be produced more efficient than before.

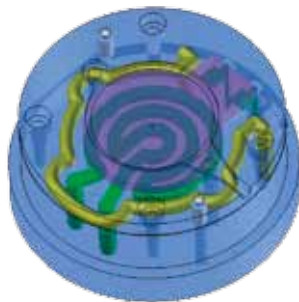
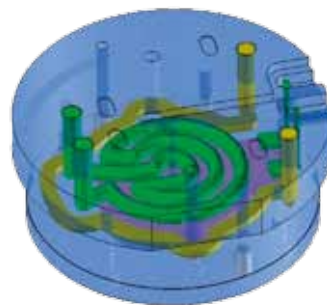

Dynamic cavity temperature control

Cavities with integrated high performance ceramic (CPH) and close-to-cavity cooling



integrat evolution Funktionalität und design

Heating: Inside the mould with high performance ceramic (CPH)

The dynamic cavity temperature control relocates the heater from the temperature controller into the mould. Through a ceramic high performance heater located only a few millimetres behind the cavities, the desired change in temperature can be affected very rapidly with less energy expenditure.

Cooling: Via temperature controller with fluid medium

The cooling of the mould walls happens through a temperature controller with direct cooling and low outlet temperature. The cooling is effected close-to-cavity through water and serves simultaneously to insulate the mould from the heater. Hereby an intensive and short cooling phase is ensured. The start of the cooling phase is initiated by a machine signal. After the end of the cooling phase, the mould opens and the next cycle starts.

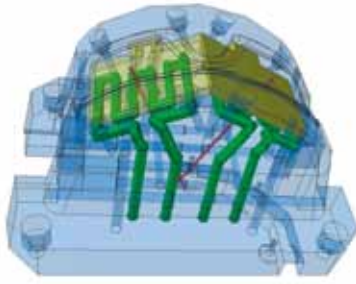

Interface injection moulding machine

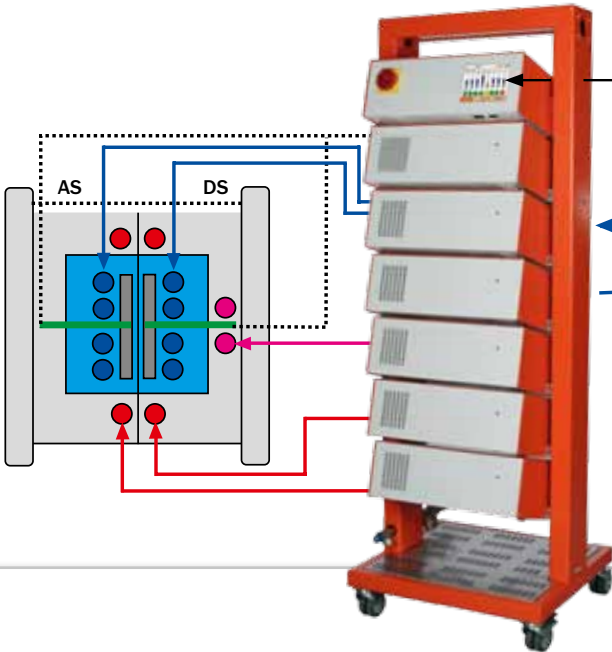

The dynamic cavity temperature control offers new technological possibilities to develop new injection moulding procedures. Example: Production of electroconductive plastic/metal parts in an adiabatic and one-level multi-component injection moulding process.

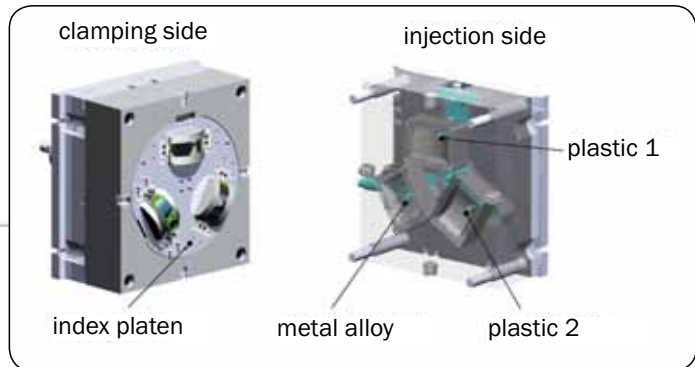

High performance mould inserts and integrat 4D

The integrated high performance mould inserts with ceramic power heaters (CPH) and close-to-cavity cooling are responsible for the highly dynamic temperature control. Independent from the temperature of the main mould they highly efficiently control the temperature profile of each individual cavity with heating / cooling cycles of up to 25 K/sec. Process control is handled by the central controller of the heating unit which simultaneously ensures a uniform temperature of the mould.

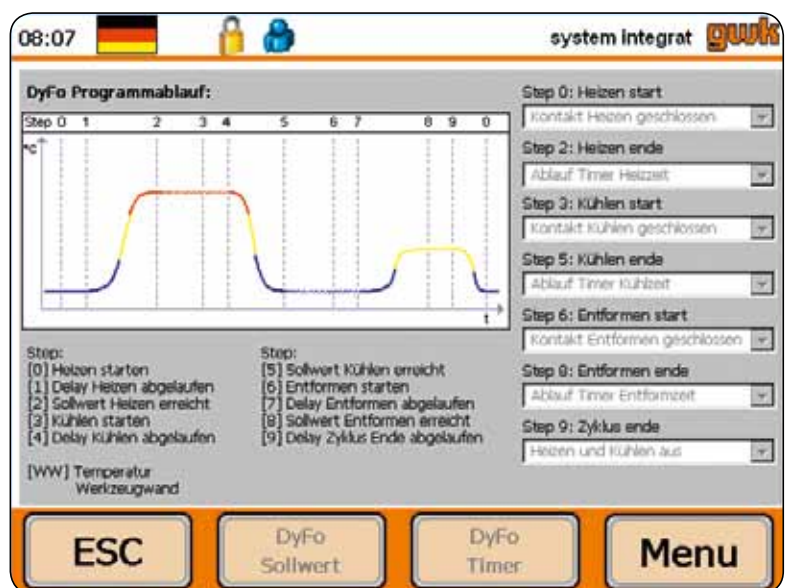



integrat vario cs/wh

Cyclic mould heating and cooling with water

Applications that are based on heat transfer fluids require either two temperature controllers or a special two-circuit unit where one circuit operates for heating and the other one for cooling. The two-step temperature control is achieved by the fact that at first the hot medium flows through the temperature control channels and thereafter the exchange with the colder medium is effected.

Temperature sensors, machine signals and adjustable time periods control the valve groups that are responsible for the switch-over between the two temperature control circuits. Depending on the temperatures required for the process the right temperature control system is selected that can reach fast heating and cooling rates with low energy consumption.

The systems of the **integrat vario cs** series are working with water up to 160 °C where as the **integrat vario wh** realizes water temperatures up to 200 °C.

The modular design allows a system configuration that is adjusted to the individual process requirements.



Reduce cycle time



Improve parts quality



Minimize reject rates



Increase productivity

er up to 160 °C / 200 °C





Scratch-proof coatings



integrat vario cs/wh Funktionalität und design

Heating: Via temperature controller with fluid medium

The heating process of the mould wall to a high temperature level is affected through a pressurized hot water temperature control with maximum outlet temperatures of up to 200 °C. The hot circulation medium is pumped through the temperature control channels situated close to the cavity, until a temperature sensor indicates the achievement of the desired mould wall temperature and releases the injection process.

Cooling: Via temperature controller with fluid medium

The cooling of the mould wall happens through a temperature controller with highly efficient plate heat exchanger and very low outlet temperature. Hereby an intensive and short cooling phase is ensured. The start of the cooling phase is initiated by a machine signal. After the end of the cooling phase, the mould opens and the heating phase for the next cycle begins.

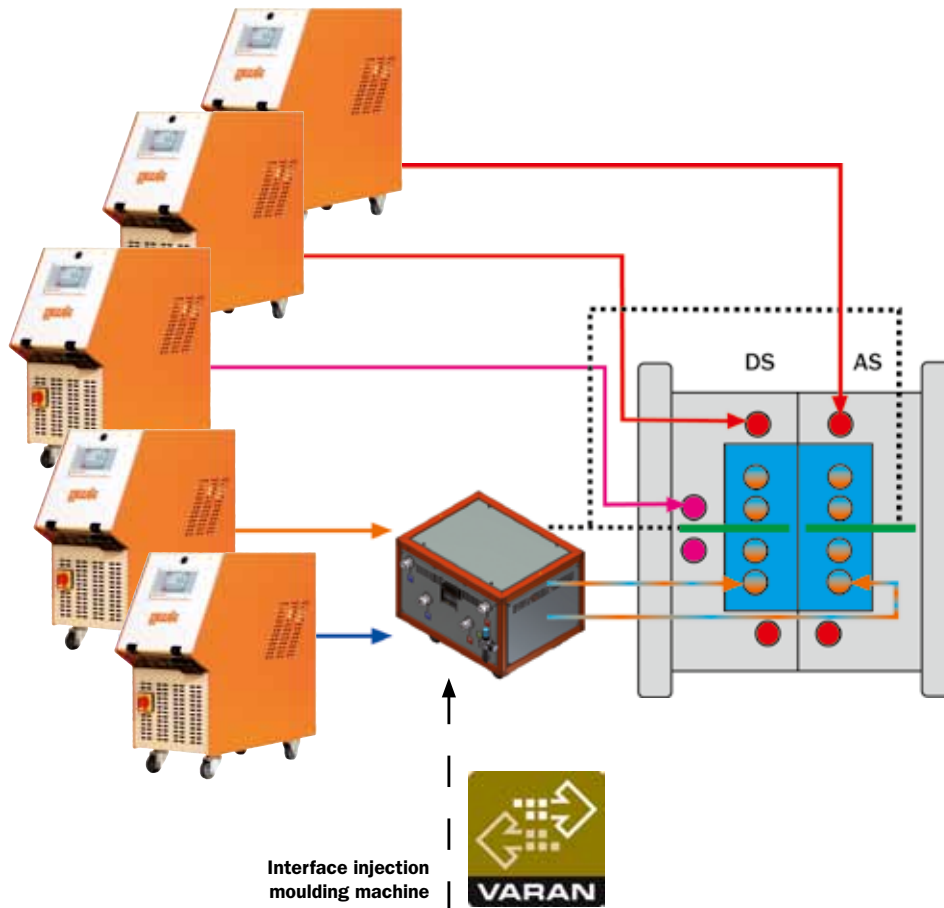

Close-to-cavity energy buffer and controlling unit

The shift between heating and cooling phase is affected by a close-to-cavity placed valve unit. The disadvantage of conventional temperature control units that rests on a high energy input due to the change between heating and cooling of the circulation medium, can now be avoided by means of the highly efficient energy storage and regulation unit. The ESR stores the varying amounts of heat and releases them to the process when the temperature level reverses. The energy buffer is controlled by a micro processor unit which adapts automatically to the cycle times and the size of the mould.

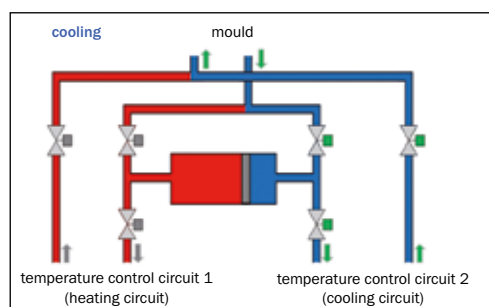
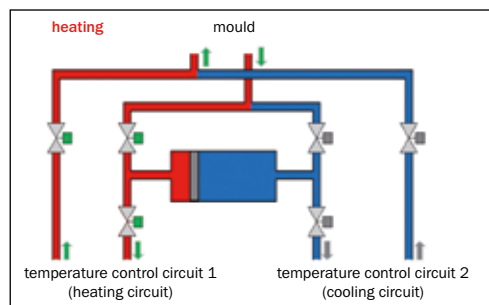



integrat vario gt

Waterless dynamic cavity temperature control

Ceramic or induction heaters are a viable heating method for many applications. However, areas of application that do not benefit from these methods or the cooling phase in general demand an alternative. Gaseous media may be useful in some cases, as they eliminate the risk of contamination.

On the downside, they have a relatively bad heat transfer capacity. This applies to air, which is therefore rarely used for cooling. Carbon dioxide, however, has a lot of potential. Brand-new perspectives and possibilities are offered by the dynamic temperature control with CO₂. This new and environment-friendly procedure really provides a solution for heating and cooling of complex and thinwalled moulded parts. By using gaseous media for heating and cooling processes, soiled cooling channels are now a thing of the past.

Basically it is true that gaseous media have the disadvantage to be bad heat carriers. This applies at least to air that is only used for cooling processes under special circumstances. But in contrast, if the opportunities of CO₂ are exhausted properly, it offers an interesting alternative to conventional water temperature control.



Reduce cycle time



Improve parts quality



Minimize reject rates



Increase productivity

Control with CO₂





teco vario gt Functionality and design

Cooling with CO₂ is sufficiently tested and well-known. The high enthalpy of evaporation of the injected fluid accompanied by a temperature of -76 °C offers an extremely efficient heat transfer. As far as cooling of long and thin cores or of narrow bars is concerned, cooling with CO₂ has already been applied with great success for many years. Nevertheless, the new feature is that heating is also possible with gaseous CO₂. In the vario gt CO₂ is compressed to a suitable pressure and heated close to the mould cavity. In contrast to steam water and hot steam the medium is uncritical even in case of high temperatures. It does not tend to deposits and corrosion and has got excellent heat transfer characteristics, facts that make it ideal for dynamic temperature control. The high temperature gradient between hot and cold media is unrivalled and promises minimum cycle times.

The positive environmental effects are also an important benefit:

The CO₂ applied is an extract of by-products from chemical processes, which would normally be emitted directly into the environment. Thanks to a new technique developed by Linde, ISK and gwk, however, it is refined and thus becomes suitable for the dynamic temperature control of narrow and otherwise inaccessible mould sections and complex part geometries. In contrast to all other techniques, this temperature control method does not put any requirements on the cooling system, neither in terms of temperature, pressure, volumetric flow rates or water quality. The waterless temperature control is very well-suited for applications under clean-room production conditions.

The dynamic mould heating and cooling with CO₂ is very well-suited for the waterless operation of injection moulds in high temperature applications.

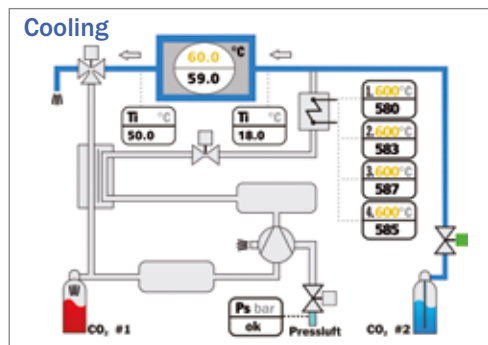
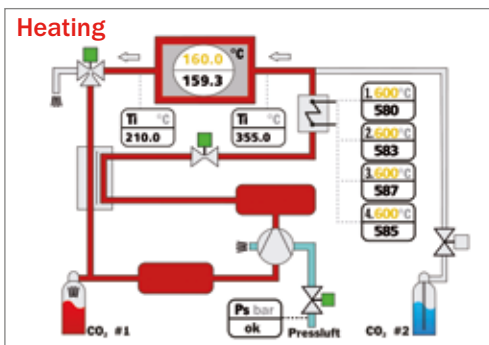

In the heating process the CO₂ is led through the cavity in a closed circuit. A compressor consolidates the gas to a pressure range of approx. 26 bar and pumps the CO₂ through a gas heater that is installed close to the mould into the mould insert. Through a 3-way-motor valve the gas is conveyed to a collection tank and is then recompressed.

After injection of the moulding material into the cavity the cooling process is released by the injection moulding machine. The CO₂ is taken out of an immersion pipe bottle and supplied pulse by pulse via a cooling valve into the temperature control channels of the cavity. There it expands gaseously and extracts the heat from the cavity by phase transformation.

gwk Perfect Cooling and Temperature Control

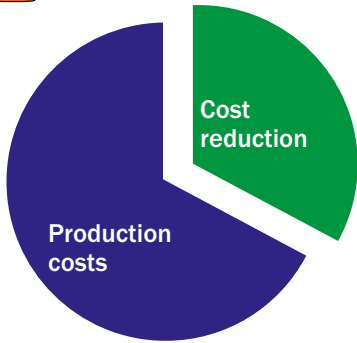

Increased productivity

In many areas of the industry, cooling and temperature control provides a great potential for increasing productivity and thus for lowering costs.

Many factors serve to improve productivity:

- Reduction of cooling time, therefore savings in required machine hours
- Increasing availability of production plants
- Improvement of product quality
- Decreasing running cost
- Reduction of maintenance cost



gwk integrat 4D

Optimal product quality through homogeneous temperature distribution by temperature control with close-to-cavity mould inserts.



gwk weco

Controllable production in variable climatic conditions and high flexibility with compact, energy-saving water chillers using environmentally friendly refrigerant.



gwk teco cs

The universal solution for standard applications in the temperature range up to 160 °C. Provides efficient options for continuous process monitoring.



gwk hermeticool hybrid

Innovative cooling system to decrease the running and maintenance cost in comparison to conventional cooling systems.



gwk system integrat

Increase of productivity by means of specific and segmented mould temperature control.



gwk container-plants

Highest flexibility and lowest expenses for planning, installation and relocation of a centralised cooling plant.



gwk tecma

High process stability with customised temperature control solutions for all applications with high performance requirements up to 400 °C.



gwk moldclean

Increased productivity through effective, automatically controlled cleaning of heat exchange surfaces in cooling and temperature controlled circuits.



gwk teco cw

Most economic system to extract heat from consumers at very low temperatures by patented cold water temperature control.



gwk service

Decreasing the maintenance cost and protection of company owned resources through professional execution of installation and maintenance works incl. cooling water treatment.



gwk Gesellschaft Wärme Kältetechnik mbH
 Scherl 10 · D-58540 Meinerzhagen
 Tel. +49 2354 7060-0 · Fax +49 2354 7060-156
 info@gwk.com · www.gwk.com

