

For the mobile version of this guide, see:
animatics.com/docs/guides-html/c6_enetse/



Ethernet Serial Encapsulation Guide

Class 6 SmartMotor
Technology



Copyright Notice

©2017, Moog Inc., Animatics.

Moog Animatics Class 6 SmartMotor™ Ethernet Serial Encapsulation Guide, PN: SC80100017-001, Rev. B.

This manual, as well as the software described in it, is furnished under license and may be used or copied only in accordance with the terms of such license. The content of this manual is furnished for informational use only, is subject to change without notice and should not be construed as a commitment by Moog Inc., Animatics. Moog Inc., Animatics assumes no responsibility or liability for any errors or inaccuracies that may appear herein.

Except as permitted by such license, no part of this publication may be reproduced, stored in a retrieval system or transmitted, in any form or by any means, electronic, mechanical, recording, or otherwise, without the prior written permission of Moog Inc., Animatics.

The programs and code samples in this manual are provided for example purposes only. It is the user's responsibility to decide if a particular code sample or program applies to the application being developed and to adjust the values to fit that application.

Moog Animatics and the Moog Animatics logo, SmartMotor and the SmartMotor logo, Combitronic and the Combitronic logo are all trademarks of Moog Inc., Animatics. Other trademarks are the property of their respective owners.

Please let us know if you find any errors or omissions in this manual so that we can improve it for future readers. Such notifications should contain the words "Ethernet Serial Encapsulation Guide" in the subject line and be sent by e-mail to: animatics_marcom@moog.com. Thank you in advance for your contribution.

Contact Us:

Americas - West

Moog Animatics
2581 Leghorn Street
Mountain View, CA 94043
USA
Tel: 1 650-960-4215

Americas - East

Moog Animatics
750 West Sproul Road
Springfield, PA 19064
USA
Tel: 1 610-328-4000 x3999
Fax: 1 610-605-6216

Support: 1 (888) 356-0357

Website: www.animatics.com

Email: animatics_sales@moog.com

Table Of Contents

Introduction	4
Purpose	5
Safety Information	6
Safety Symbols	6
Other Safety Considerations	6
Safety Information Resources	8
Additional Documents	9
Related Guides	9
Other Documents	9
Additional Resources	10
Motor Pinouts, Connections and Status LEDs	11
Connecting the System	12
Class 6 M-Style EIP Motors: Connectors and Pinouts	12
Moog Animatics Industrial Ethernet Cables	13
Ethernet Custom Cable	13
Cable Diagram	14
Understanding the Status LEDs	15
Using Ethernet Serial Encapsulation	16
Ethernet Serial Encapsulation Description	17
TCP Port	17
UDP Port	17
Detecting the Motors in SMI	18
Setting the IP Address	18
Supported/Not-Supported Functionality	19
Supported Functionality	19
Not-Supported Functionality	20
Ethernet Serial Encapsulation Communications Setup	21
Ethernet Serial Encapsulation Sample Command Sequences	21
UDP (User Datagram Protocol) Discovery Example	23
TCP (Transmission Control Protocol) Command Examples	24
Troubleshooting	29

Introduction

This chapter provides information on the purpose and scope of this manual. It also provides information on safety notation, related documents and additional resources.

Purpose	5
Safety Information	6
Safety Symbols	6
Other Safety Considerations	6
Safety Information Resources	8
Additional Documents	9
Related Guides	9
Other Documents	9
Additional Resources	10

Purpose

This guide describes the Moog Animatics Ethernet Serial Encapsulation protocol provided by the Class 6 EtherNet/IP (EIP) SmartMotor™ (see the following figure). It describes the major concepts that must be understood to integrate a SmartMotor slave with an Ethernet Serial Encapsulation master device. It also includes a byte-by-byte discussion of the Moog Animatics Ethernet Serial Encapsulation protocol.

NOTE: The feature set described in this version of the manual refers to SmartMotor (-EIP option) firmware version 6.0.2.28 and netX firmware (NXF) version 3.3.0.3.

NOTE: The keepalive feature to reset broken connections requires firmware 6.0.2.41 or higher with netX firmware (NXF) version 3.4.0.5 or higher. Earlier firmware versions will not activate this feature.

The Ethernet Serial Encapsulation protocol was developed by Moog Animatics as a means for the Class 6 EtherNet/IP (EIP) motor to receive and send serial communications over Ethernet. In addition to this protocol, Moog Animatics offers a variety of other fieldbus protocol options for the Class 6 M-style motors, such as EtherNet/IP, Modbus, and more. Please contact Moog Animatics for details.



Model: SM23166MT



Model: SM23166MT2

Safety Information

This section describes the safety symbols and other safety information.

Safety Symbols

The manual may use one or more of the following safety symbols:



WARNING: This symbol indicates a potentially non-lethal mechanical hazard, where failure to follow the instructions could result in serious injury to the operator or major damage to the equipment.



CAUTION: This symbol indicates a potential minor hazard, where failure to follow the instructions could result in slight injury to the operator or minor damage to the equipment.

NOTE: Notes are used to emphasize non-safety concepts or related information.

Other Safety Considerations

The Moog Animatics SmartMotors are supplied as components that are intended for use in an automated machine or system. As such, it is beyond the scope of this manual to attempt to cover all the safety standards and considerations that are part of the overall machine/system design and manufacturing safety. Therefore, the following information is intended to be used only as a general guideline for the machine/system designer.

It is the responsibility of the machine/system designer to perform a thorough "Risk Assessment" and to ensure that the machine/system and its safeguards comply with the safety standards specified by the governing authority (for example, ISO, OSHA, UL, etc.) for the locale where the machine is being installed and operated. For more details, see Machine Safety on page 7.

Motor Sizing

It is the responsibility of the machine/system designer to select SmartMotors that are properly sized for the specific application. Undersized motors may: perform poorly, cause excessive downtime or cause unsafe operating conditions by not being able to handle the loads placed on them. The *Moog Animatics Product Catalog*, contains information and equations that can be used for selecting the appropriate motor for the application.

Replacement motors must have the same specifications and firmware version used in the approved and validated system. Specification changes or firmware upgrades require the approval of the system designer and may require another Risk Assessment.

Environmental Considerations

It is the responsibility of the machine/system designer to evaluate the intended operating environment for dust, high-humidity or presence of water (for example, a food-processing environment that requires water or steam wash down of equipment), corrosives or chemicals that may come in contact with the machine, etc. Moog Animatics manufactures specialized IP-rated motors for operating in extreme conditions. For details, see the *Moog Animatics Product Catalog*.

Machine Safety

In order to protect personnel from any safety hazards in the machine or system, the machine/system builder must perform a "Risk Assessment", which is often based on the ISO 13849 standard. The design/implementation of barriers, emergency stop (E-stop) mechanisms and other safeguards will be driven by the Risk Assessment and the safety standards specified by the governing authority (for example, ISO, OSHA, UL, etc.) for the locale where the machine is being installed and operated. The methodology and details of such an assessment are beyond the scope of this manual. However, there are various sources of Risk Assessment information available in print and on the internet.

NOTE: The following list is an example of items that would be evaluated when performing the Risk Assessment. Additional items may be required. The safeguards must ensure the safety of all personnel who may come in contact with or be in the vicinity of the machine.

In general, the machine/system safeguards must:

- Provide a barrier to prevent unauthorized entry or access to the machine or system. The barrier must be designed so that personnel cannot reach into any identified danger zones.
- Position the control panel so that it is outside the barrier area but located for an unrestricted view of the moving mechanism. The control panel must include an E-stop mechanism. Buttons that start the machine must be protected from accidental activation.
- Provide E-stop mechanisms located at the control panel and at other points around the perimeter of the barrier that will stop all machine movement when tripped.
- Provide appropriate sensors and interlocks on gates or other points of entry into the protected zone that will stop all machine movement when tripped.
- Ensure that if a portable control/programming device is supplied (for example, a hand-held operator/programmer pendant), the device is equipped with an E-stop mechanism.

NOTE: A portable operation/programming device requires *many* additional system design considerations and safeguards beyond those listed in this section. For details, see the safety standards specified by the governing authority (for example, ISO, OSHA, UL, etc.) for the locale where the machine is being installed and operated.

- Prevent contact with moving mechanisms (for example, arms, gears, belts, pulleys, tooling, etc.).
- Prevent contact with a part that is thrown from the machine tooling or other part-handling equipment.
- Prevent contact with any electrical, hydraulic, pneumatic, thermal, chemical or other hazards that may be present at the machine.
- Prevent unauthorized access to wiring and power-supply cabinets, electrical boxes, etc.
- Provide a proper control system, program logic and error checking to ensure the safety of all personnel and equipment (for example, to prevent a run-away condition). The control system must be designed so that it does not automatically restart the machine/system after a power failure.
- Prevent unauthorized access or changes to the control system or software.

Documentation and Training

It is the responsibility of the machine/system designer to provide documentation on safety, operation, maintenance and programming, along with training for all machine operators, maintenance technicians, programmers, and other personnel who may have access to the machine. This documentation must include proper lockout/tagout procedures for maintenance and programming operations.

It is the responsibility of the operating company to ensure that:

- All operators, maintenance technicians, programmers and other personnel are tested and qualified before acquiring access to the machine or system.
- The above personnel perform their assigned functions in a responsible and safe manner to comply with the procedures in the supplied documentation and the company safety practices.
- The equipment is maintained as described in the documentation and training supplied by the machine/system designer.

Additional Equipment and Considerations

The Risk Assessment and the operating company's standard safety policies will dictate the need for additional equipment. In general, it is the responsibility of the operating company to ensure that:

- Unauthorized access to the machine is prevented at all times.
- The personnel are supplied with the proper equipment for the environment and their job functions, which may include: safety glasses, hearing protection, safety footwear, smocks or aprons, gloves, hard hats and other protective gear.
- The work area is equipped with proper safety equipment such as first aid equipment, fire suppression equipment, emergency eye wash and full-body wash stations, etc.
- There are no modifications made to the machine or system without proper engineering evaluation for design, safety, reliability, etc., and a Risk Assessment.

Safety Information Resources

Additional SmartMotor safety information can be found on the Moog Animatics website; open the file "109_Controls, Warnings and Cautions.pdf" located at:

<http://www.animatics.com/support/moog-animatics-catalog.html>

OSHA standards information can be found at:

<https://www.osha.gov/law-regs.html>

ANSI-RIA robotic safety information can be found at:

<http://www.robotics.org/robotic-content.cfm/Robotics/Safety-Compliance/id/23>

UL standards information can be found at:

<http://ulstandards.ul.com/standards-catalog/>

ISO standards information can be found at:

<http://www.iso.org/iso/home/standards.htm>

EU standards information can be found at:

http://ec.europa.eu/growth/single-market/european-standards/harmonised-standards/index_en.htm

Additional Documents

The Moog Animatics website contains additional documents that are related to the information in this manual. Please refer to the following list.

Related Guides

- *Class 6 SmartMotor™ Installation and Startup Guide*
<http://www.animatics.com/cl-6-install-startup-guide>
- *SmartMotor™ Developer's Guide*
<http://www.animatics.com/smartmotor-developers-guide>

Other Documents

- *SmartMotor™ Product Certificate of Conformance*
<http://www.animatics.com/download/Declaration of Conformity.pdf>
- *SmartMotor™ UL Certification*
http://www.animatics.com/download/MA_UL_online_listing.pdf
- *SmartMotor Developer's Worksheet*
(interactive tools to assist developer: Scale Factor Calculator, Status Words, CAN Port Status, Serial Port Status, RMODE Decoder and Syntax Error Codes)
<http://www.animatics.com/tools>
- *Moog Animatics Product Catalog*
<http://www.animatics.com/support/moog-animatics-catalog.html>

Additional Resources

The Moog Animatics website contains additional resources such as product information, documentation, product support and more. Please refer to the following list:

- General company information:
<http://www.animatics.com>
- Product information:
<http://www.animatics.com/products.html>
- Product support (Downloads, How To videos, Forums, Knowledge Base, and FAQs):
<http://www.animatics.com/support.html>
- Sales and distributor information:
<http://www.animatics.com/sales-offices.html>
- Application ideas (including videos and sample programs):
<http://www.animatics.com/applications.html>

Motor Pinouts, Connections and Status LEDs

The following sections describe the motor pinouts, system connections and the status LEDs.

Connecting the System	12
Class 6 M-Style EIP Motors: Connectors and Pinouts	12
Moog Animatics Industrial Ethernet Cables	13
Ethernet Custom Cable	13
Cable Diagram	14
Understanding the Status LEDs	15

Connecting the System

The following sections show system connections and cable diagrams for typical Class 6 M-style EIP motors.

Class 6 M-Style EIP Motors: Connectors and Pinouts

The following figure provides a brief overview of the connectors and pinouts available on the Class 6 M-style SmartMotors. Additional connector specifications are available in the *Class 6 SmartMotor™ Installation Guide*.

The EtherNet/IP (industrial Ethernet) ports are used to connect the motor to the Ethernet network. See the figure below for the location of those ports.

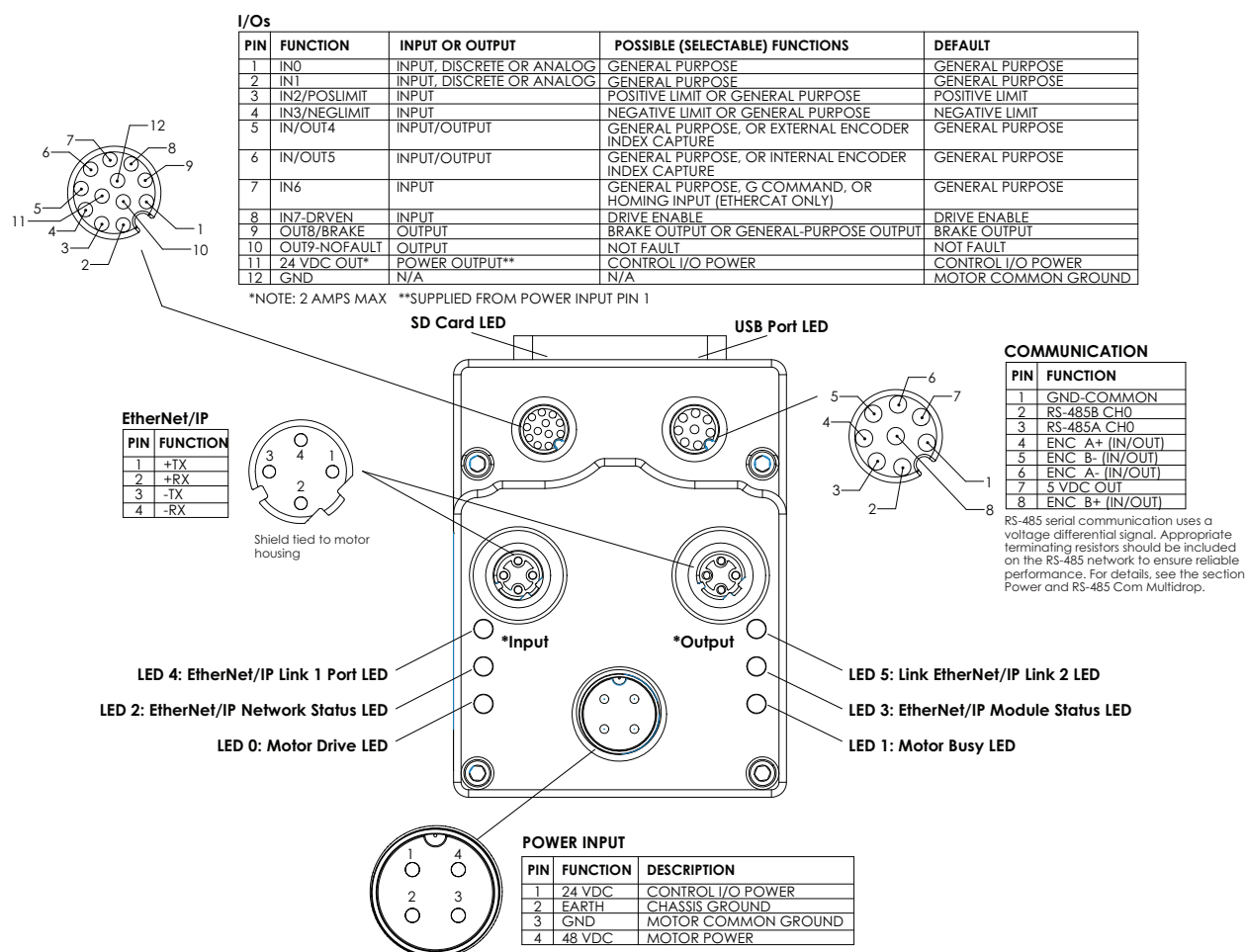

NOTE: When daisy-chaining SmartMotors for an Ethernet Serial Encapsulation network, there is no specific IN or OUT Ethernet port. In other words, either Ethernet port can be used for the input or the output.

Moog Animatics Industrial Ethernet Cables

The following Industrial Ethernet cables are available from Moog Animatics.

M-style to M-style Ethernet Cable

This cable has M12 male threaded connectors at both ends. It is available in 1, 3, 5 and 10 meter lengths. For the standard cable, use part number CBLIP-ETH-MM-xM, where "x" denotes the cable length. A right-angle version is also available; use part number CBLIP-ETH-MM-xMRA.

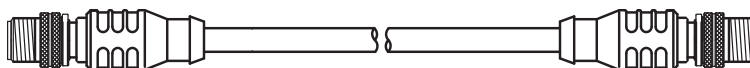

M-style to RJ45 Ethernet Cable

This cable has an M12 male threaded connector at one end, and an RJ45 male connector at the opposite end. It is available in 1, 3, 5 and 10 meter lengths. For the standard cable, use part number CBLIP-ETH-MRJ-xM, where "x" denotes the cable length. A right-angle version is also available; use part number CBLIP-ETH-MRJ-xMRA.

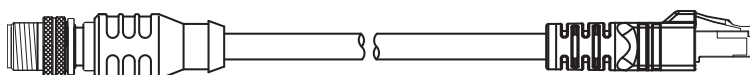

Ethernet Custom Cable

The following figure provides details for creating a custom shielded Ethernet cable.

NOTE: The motor end of the cable requires an industrial Ethernet connector.

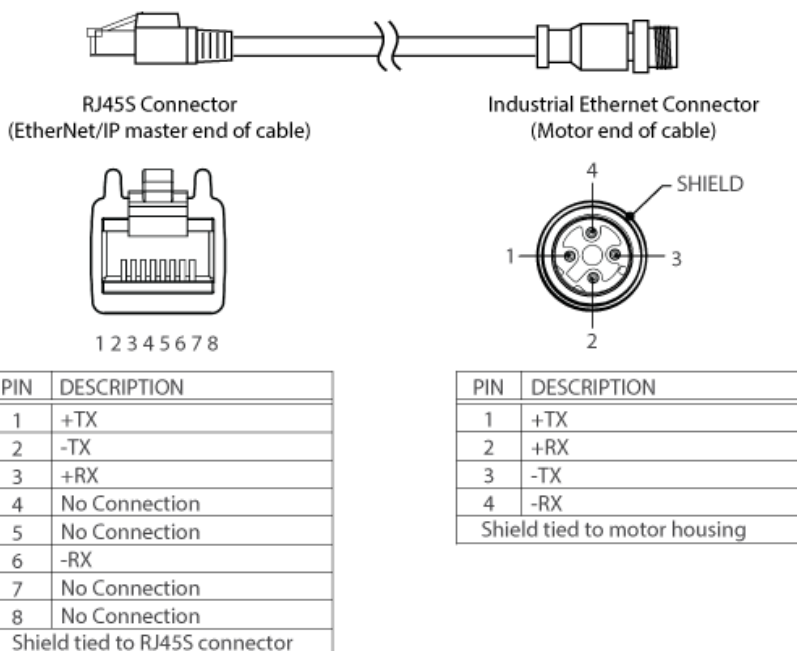

Cable Diagram

The following figures show a Ethernet Serial Encapsulation master connected to a series of slave devices. Although only two configurations are shown, many different network topologies are possible. Other devices (routers, gateways, etc.) may also be on the network. See the previous page for cable part numbers.

Ethernet TCP/IP Network

Example Daisy-Chain Configuration

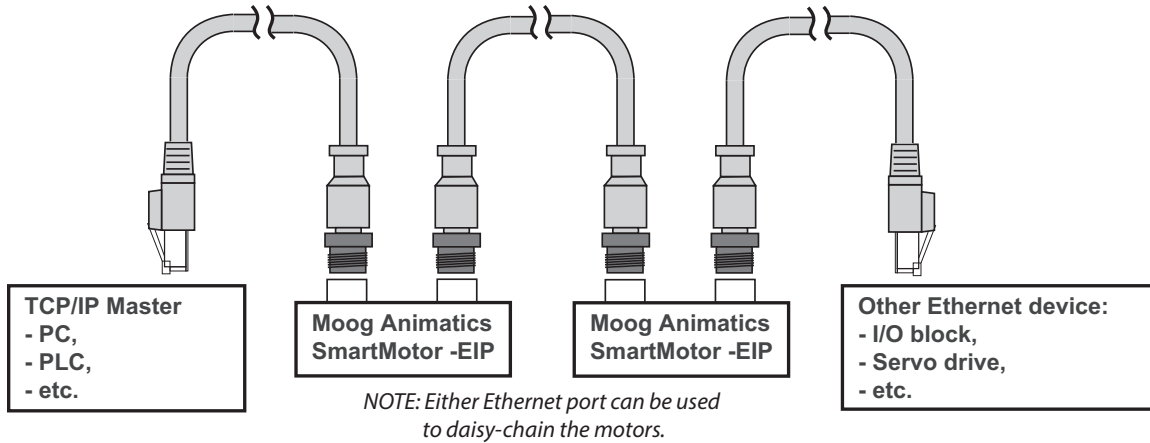

NOTE: Unlike other fieldbus protocols, this configuration does not require terminators at each end of the network.

Ethernet TCP/IP Network

Example Star Configuration

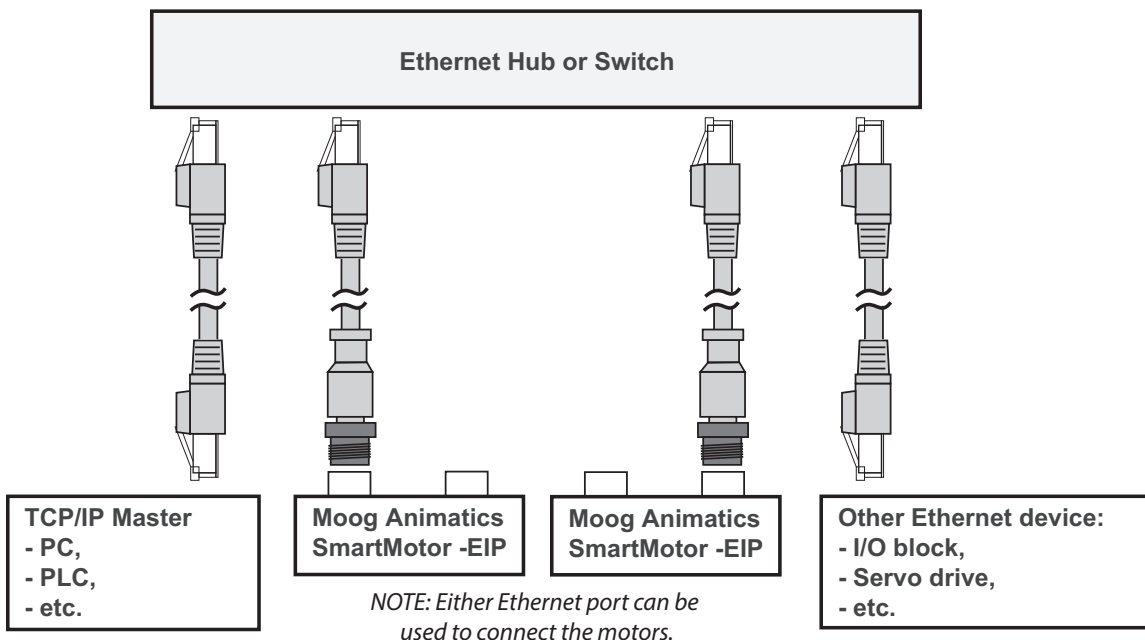

NOTE: Unlike other fieldbus protocols, this configuration does not require terminators at each end of the network.

Understanding the Status LEDs

The following figure and tables describe the functionality of the Ethernet Serial Encapsulation Status LEDs on the Class 6 EIP SmartMotor.

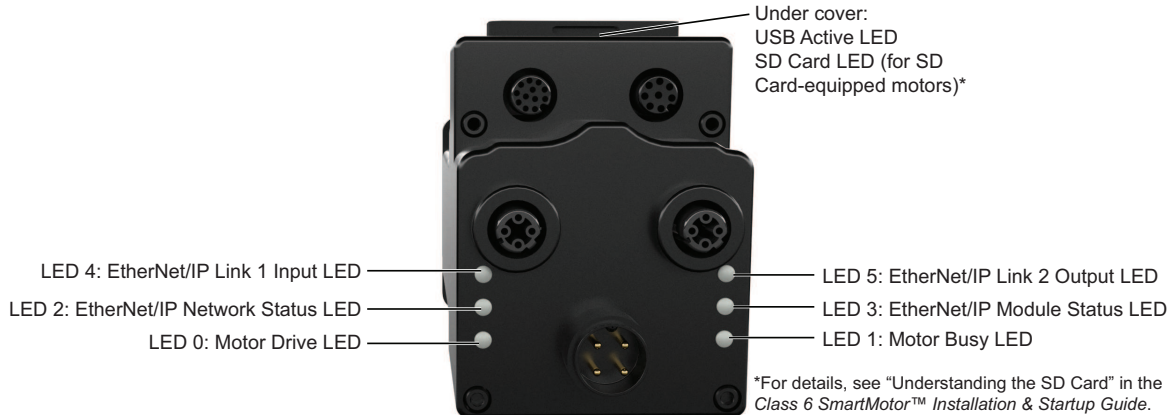

Flickering = On/Off in 0.1 sec; Blinking = On/Off in 0.5 sec; Flashing = separated by 1 sec for EtherNet/IP LEDs and 2 sec for Fault Codes

<p>SD Card LED (for SD Card-equipped motors)</p> <table border="0"> <tr><td>Off</td><td>No card, bad or damaged card</td></tr> <tr><td>Blinking green</td><td>Busy, do not remove card</td></tr> <tr><td>Solid green</td><td>Card detected</td></tr> <tr><td>Solid red</td><td>Card with no SmartMotor data</td></tr> </table>	Off	No card, bad or damaged card	Blinking green	Busy, do not remove card	Solid green	Card detected	Solid red	Card with no SmartMotor data	<p>USB Active LED</p> <table border="0"> <tr><td>Flashing green</td><td>Active</td></tr> <tr><td>Flashing red</td><td>Suspended</td></tr> <tr><td>Solid red</td><td>USB power detected, no configuration</td></tr> </table>	Flashing green	Active	Flashing red	Suspended	Solid red	USB power detected, no configuration																																						
Off	No card, bad or damaged card																																																				
Blinking green	Busy, do not remove card																																																				
Solid green	Card detected																																																				
Solid red	Card with no SmartMotor data																																																				
Flashing green	Active																																																				
Flashing red	Suspended																																																				
Solid red	USB power detected, no configuration																																																				
<p>LED 0: Motor Drive LED</p> <table border="0"> <tr><td>Off</td><td>No power</td></tr> <tr><td>Solid green</td><td>Drive on</td></tr> <tr><td>Blinking green</td><td>Drive off, no faults</td></tr> <tr><td>Triple red flash</td><td>Watchdog fault</td></tr> <tr><td>Solid red</td><td>Faulted or no drive enable input</td></tr> </table> <p>LED 2: EtherNet/IP Network Status LED</p> <table border="0"> <tr><td>Off</td><td>No power or no IP address</td></tr> <tr><td>Flashing red/grn</td><td>Power-up self test</td></tr> <tr><td>Flashing green</td><td>No connections</td></tr> <tr><td>Solid green</td><td>Connected</td></tr> <tr><td>Flashing red</td><td>Connection timeout</td></tr> <tr><td>Solid red</td><td>Duplicate IP</td></tr> </table> <p>LED 4: EtherNet/IP Link 1 Input LED</p> <table border="0"> <tr><td>Off</td><td>No/bad cable; no/bad Link port</td></tr> <tr><td>Solid green</td><td>Link established</td></tr> <tr><td>Blinking green</td><td>Activity</td></tr> </table>	Off	No power	Solid green	Drive on	Blinking green	Drive off, no faults	Triple red flash	Watchdog fault	Solid red	Faulted or no drive enable input	Off	No power or no IP address	Flashing red/grn	Power-up self test	Flashing green	No connections	Solid green	Connected	Flashing red	Connection timeout	Solid red	Duplicate IP	Off	No/bad cable; no/bad Link port	Solid green	Link established	Blinking green	Activity	<p>LED 1: Motor Busy LED</p> <table border="0"> <tr><td>Off</td><td>Not busy</td></tr> <tr><td>Solid green</td><td>Drive on, trajectory in progress</td></tr> <tr><td>Flashing # red</td><td>Flashes fault code* (see below) when Drive LED is solid red</td></tr> </table> <p>LED 3: EtherNet/IP Module Status LED</p> <table border="0"> <tr><td>Off</td><td>No power</td></tr> <tr><td>Flashing red/grn</td><td>Power-up self test</td></tr> <tr><td>Flashing green</td><td>Standby</td></tr> <tr><td>Solid green</td><td>Device operational</td></tr> <tr><td>Flashing red</td><td>Minor fault</td></tr> <tr><td>Solid red</td><td>Major fault</td></tr> </table> <p>LED 5: EtherNet/IP Link 2 Output LED</p> <table border="0"> <tr><td>Off</td><td>No/bad cable; no/bad Link port</td></tr> <tr><td>Solid green</td><td>Link established</td></tr> <tr><td>Blinking green</td><td>Activity</td></tr> </table>	Off	Not busy	Solid green	Drive on, trajectory in progress	Flashing # red	Flashes fault code* (see below) when Drive LED is solid red	Off	No power	Flashing red/grn	Power-up self test	Flashing green	Standby	Solid green	Device operational	Flashing red	Minor fault	Solid red	Major fault	Off	No/bad cable; no/bad Link port	Solid green	Link established	Blinking green	Activity
Off	No power																																																				
Solid green	Drive on																																																				
Blinking green	Drive off, no faults																																																				
Triple red flash	Watchdog fault																																																				
Solid red	Faulted or no drive enable input																																																				
Off	No power or no IP address																																																				
Flashing red/grn	Power-up self test																																																				
Flashing green	No connections																																																				
Solid green	Connected																																																				
Flashing red	Connection timeout																																																				
Solid red	Duplicate IP																																																				
Off	No/bad cable; no/bad Link port																																																				
Solid green	Link established																																																				
Blinking green	Activity																																																				
Off	Not busy																																																				
Solid green	Drive on, trajectory in progress																																																				
Flashing # red	Flashes fault code* (see below) when Drive LED is solid red																																																				
Off	No power																																																				
Flashing red/grn	Power-up self test																																																				
Flashing green	Standby																																																				
Solid green	Device operational																																																				
Flashing red	Minor fault																																																				
Solid red	Major fault																																																				
Off	No/bad cable; no/bad Link port																																																				
Solid green	Link established																																																				
Blinking green	Activity																																																				

LED Status on Power-up:

- With no program and the travel limit inputs are low:
LED 0 solid red; motor is in fault state due to travel limit fault
LED 1 off
- With no program and the travel limits are high:
LED 0 solid red for 500 milliseconds then flashing green
LED 1 off
- With a program that only disables travel limits:
LED 0 red for 500 milliseconds then flashing green
LED 1 off

LED1 Fault Codes:

Flash	Description
1	NOT Used
2	Bus Voltage
3	Over Current
4	Excessive Temperature
5	Excessive Position
6	Velocity Limit
7	dE/Dt - First derivative of position error is excessive
8	Hardware Positive Limit Reached
9	Hardware Negative Limit Reached
10	Software Positive Travel Limit Reached
11	Software Negative Travel Limit Reached

*Busy LED pauses for 2 seconds before flashing the code

Using Ethernet Serial Encapsulation

The following sections describe how to enable Ethernet Serial Encapsulation communications with your SmartMotor, along with information on supported function codes, input registers and holding registers.

Ethernet Serial Encapsulation Description	17
TCP Port	17
UDP Port	17
Detecting the Motors in SMI	18
Setting the IP Address	18
Supported/Not-Supported Functionality	19
Supported Functionality	19
Not-Supported Functionality	20
Ethernet Serial Encapsulation Communications Setup	21
Ethernet Serial Encapsulation Sample Command Sequences	21
UDP (User Datagram Protocol) Discovery Example	23
TCP (Transmission Control Protocol) Command Examples	24

Ethernet Serial Encapsulation Description

Ethernet Serial Encapsulation is a protocol developed by Moog Animatics that allows host software, such as SMI, to communicate via serial commands over Ethernet. The Moog Animatics Class 6 EtherNet/IP (EIP) SmartMotor supports communication with a PLC, HMI, or other host device over Ethernet.

Unlike Modbus RTU serial communication, the OCHN command is not needed or used for Ethernet Serial Encapsulation communication. In fact, once the motors are connected to the Ethernet network, they will be able to communicate with the Ethernet Serial Encapsulation master if DHCP is used, or they will simply need a static IP address if DHCP is not being used.

TCP Port

There is a single instance of the TCP port that acts like a serial command parser. Note that a second concurrent attempt to connect will be rejected. However, if the first connection is closed by the client, then the motor will accept another connection.



CAUTION: There is no security check or other method available to disable the TCP port. Therefore, the network is assumed to be "friendly" (i.e., secure, ready and safe to connect to).

TCP Port 10001

The TCP port uses ASCII commands to create a "pipeline" to the same handling as a serial port, as follows:

- Prepend with a byte of the value: 0x80
- Terminate with a byte of the value: 0x20 (a space)
- Responses terminate with 0x0d

Example:

- Command: 0x80RPA0x20 = "0x80RPA " (note there is a space at the end).
- Response: 102330x0d = the number 10233 with the byte value 0x0d at the end.

UDP Port

Optionally, and unrelated to the TCP connection, a broadcast to port 30718 over UDP can be used to discover the SmartMotor(s).

UDP port 30718

Send a UDP packet broadcast:

To address 255.255.255.255, port 30718 with the BCAST flag:

1. Send the packet from your port 30718
2. Send this data:
 - Datagram length: four bytes
 - Content (from first to last): 0x00, 0x00, 0x00, 0xf6

Listen for response back to your port 30718:

1. Check that data length received is 30 bytes.
2. Check that the first four bytes (0-3) are:
0x00, 0x00, 0x00, 0xf7
3. For the remaining bytes:
 - Bytes 4-23 should all be 0
 - Bytes 24-29 represent the MAC ID of the motor

Detecting the Motors in SMI

When using the Detect Motors feature in SMI to detect the SmartMotor(s), they will be detected as "Ethernet". Note the following:

- The ability to change the SmartMotor IP address through the SMI menus and dialogs will not function. However, you can use SMI software's Terminal window to issue commands that set the IP address. See the SMI software's online help for details on the Terminal window.
- The SmartMotor "webpage" feature, also used to set the IP address, will not function.

Therefore, the IP address must be set through either:

- The IP Control command (IPCTL), or
- The SmartMotor's USB port

For details, refer to the following section.

Setting the IP Address

As mentioned previously, for Ethernet Serial Encapsulation on the SmartMotor, the IP address can be either static or dynamic (DHCP). The default operation is dynamic addressing. For applications requiring a fixed IP address, it must be set using the IP control command (IPCTL) through either:

- The Ethernet port, or
- The SmartMotor's USB port

The IPCTL command allows you to change the IP address of the SmartMotor. The default setting is "0.0.0.0" for IP address, subnet mask, and gateway disabled/automatic. Three function codes (0, 1, and 2) are available for setting a specific IP address, a specific subnet mask, and/or a specific gateway address, respectively. It uses the form:

```
IPCTL(function,"string")
```

- function is one of the following codes:

function	Description
0	Set IP address
1	Set subnet mask
2	Set gateway

- "string" is formatted as an IP address and entered as a string

For example:

```
IPCTL(0, "192.168.0.10") 'Set the IP address to 192.168.0.10
```

For more details on the IPCTL command, see the *SmartMotor™ Developer's Guide*. For details on the Ethernet and USB ports, see the *Class 6 SmartMotor™ Installation & Startup Guide*.

Supported/Not-Supported Functionality

Supported Functionality

A small set of functions are supported for access to these basic SmartMotor operations:

- Report commands: RPA, RSP, etc.

Report commands are shown in the *SmartMotor Developer's Guide*. They can be identified by looking at the command lists (near the end of the guide) for commands that begin with a superscript "R" character, for example: ^RPA, ^RSP, ^RPC etc.

Commands that begin with an "R" character that *is not* superscript *are not* report commands, for example: RANDOM=, RESUME, RETURN, RETURNI, RUN, RUN?.

NOTE: Also, refer to the Not-Supported Functionality section.

For more details, refer to Example with a String Response on page 24 and Example with a Numeric Response on page 25.

- Assign a variable: a=400

For more details, refer to Example of Assigning a Variable on page 26.

- Motion commands

All the motion commands listed in the Motion Control section of the SmartMotor Developer's Guide will work with the exception of the following (as these are not yet supported in Class 6 SmartMotors):

- ADTS
- ATS
- DTS
- VTS
- PTS
- PRTS
- GS
- PRTSS
- PTSS
- RPTSD
- RPTST

- User program download, run and upload.

For more details, refer to Example of Program Downloading, Running and Uploading on page 27.

- Channel 2 is always open (see Not-Supported Functionality)
- TCP keepalive feature (requires firmware 6.0.2.41 or higher with netX firmware (NXF) version 3.4.0.5 or higher.)

Not-Supported Functionality

The following SmartMotor functions are not supported:

- Serial "data" mode is not supported (for example, RGETCHR)

Report commands specific to the serial port, like RGETCHR, RGETCHR1, etc. (reporting the state of the actual serial ports) will report a value without problem. However, commands like RGETCHR2, RLEN2 are not supported specific to the state of the serial encapsulation channel itself; i.e., you can't put the serial encapsulation into "data" mode.

Any command that can be performed on the serial port should also work through Ethernet Serial Encapsulation. There are a few operations, however, that don't apply to this environment:

- Setting or reading the baud rate specific to that port
- OCHN, serial interpolation time sync
- Serial addressing
- Open channel and change channel (OCHN and CCHN, respectively) commands are not supported

NOTE: Channel 2 is always open.

Ethernet Serial Encapsulation Communications Setup

This topic contains Ethernet Serial Encapsulation communications setup information.

For a typical Ethernet Serial Encapsulation application:

- Ethernet Serial Encapsulation requires the Class 6 "-EIP" SmartMotor model. Verify that you have the correct motor.
- Verify the type of motor addressing being used. Note the following:
 - For dynamic IP (DHCP) addressing (SmartMotor default), there is no need to set an IP address on the motor.
 - For static IP addressing, you will need to set a static IP address on the motor. For more details, see Setting the IP Address on page 18.
- There is no need to open the Ethernet Serial Encapsulation port, it is already open by default (using TCP port 10001). Therefore, no special program is needed.
- There is no need for a node ID—the IP address serves as the motor's identification. Note that the Node ID is typically assumed to be "0" in Ethernet Serial Encapsulation.

Command	Purpose	Value	Non-Volatile Setting
ETHCTL(100, value)	Enable/disable ports	-1 default 0 disable TCP communications port and UDP discovery port. 1 enable TCP communications port only 2 enable UDP discovery port only 3 enable TCP communications port and UDP discovery port. (default)	Yes
ETHCTL(110, value)	Keepalive time for Ethernet serial encapsulated connection.	-1 default (3 seconds) 0 disable 1-127 keepalive time (seconds)	Yes

Ethernet Serial Encapsulation Sample Command Sequences

This topic contains some sample Ethernet Serial Encapsulation command sequences. These examples show the data sent from and received by SMI software communicating with a

SmartMotor. For these examples, an open-source software (Wireshark network protocol analyzer) is used to show the communications between SMI software and the SmartMotor.

NOTE: There are various utilities available for this purpose. Therefore, Moog Animatics does not endorse any particular one—the selection depends on the requirements of your application.

For each of the following sections:

- Section title = action being performed
- Output = formatted byte stream sent from master to the SmartMotor
- Input = formatted byte stream received by the master from the SmartMotor

For the following tables:

NOTE: A table is provided to illustrate the parts of the byte sequence only. The byte sequence must be transmitted as a stream of bytes shown in the Output/Input strings above the table (i.e., no pause or null for the blank cells).

These items unique to the UDP Discovery Example:

- Operation Code (Bytes 0-3) = specifies the operation being performed
- Reserved (Bytes 4-23) = reserved bytes
- MAC address (Bytes 24-29) = the MAC address of the responding motor

These items are common to TCP Command Examples:

- Prefix = required stream prefix (Output always 80; Input = N/A)
- Command = Output byte string representing the desired command
- Response = Input byte string representing the response from the motor
- Terminator = required stream terminator (Output always 20; Input = 0d)

TCP (Transmission Control Protocol) Command Examples

Example with a String Response

This is a TCP example with a string response; the RSP command replies with "06250/6.0.2.30"

Output: 80 52 53 50 20
Input: 30 36 32 35 30 2f 36 2e 30 2e 32 2e 33 30 0d

	TCP Stream			
	Prefix	Command	Response	Terminator
Output	80	52 53 50 ("RSP")		20
Input			30 36 32 35 30 2f 36 2e 30 2e 32 2e 33 30 ("06250/6.0.2.30")	0d

A table is provided to illustrate the parts of the byte sequence only. The byte sequence must be transmitted as a stream of bytes shown in the Output/Input strings above the table (i.e., no pause or null for the blank cells).

Output:

```

[+] Frame 44: 59 bytes on wire (472 bits), 59 bytes captured (472 bits)
[+] Ethernet II, Src: Intel_39:52:10 (90:e2:ba:39:52:10), Dst: Hilscher_2b:41:ff (00:02:a2:2b:41:ff)
[+] Internet Protocol Version 4, Src: 172.16.252.1 (172.16.252.1), Dst: 172.16.252.10 (172.16.252.10)
[+] Transmission Control Protocol, Src Port: 58203 (58203), Dst Port: scp-config (10001), Seq: 1, Ack: 1, Len: 5
    Source port: 58203 (58203)
    Destination port: scp-config (10001)
    [Stream index: 3]
    Sequence number: 1 (relative sequence number)
    [Next sequence number: 6 (relative sequence number)]
    Acknowledgement number: 1 (relative ack number)
    Header length: 20 bytes
    [+] Flags: 0x18 (PSH, ACK)
        window size value: 64240
        [Calculated window size: 64240]
        [window size scaling factor: -2 (no window scaling used)]
    [+] Checksum: 0x504d [validation disabled]
    [SEQ/ACK analysis]
[+] Data (5 bytes)
    Data: 8052535020
    [Length: 5]
0000 00 02 a2 2b 41 ff 90 e2 ba 39 52 10 08 00 45 00  ...+A... .9R...E.
0010 00 2d 00 99 40 00 80 06 00 00 ac 10 fc 01 ac 10  -.@... ..
0020 fc 0a e3 5b 27 11 58 c6 fc 76 00 00 19 6f 50 18  ...['.X. .v...oP.
0030 fa f0 50 4d 00 00 80 52 53 50 20                ..PM...R SP
    
```

Input:

```

[+] Frame 45: 69 bytes on wire (552 bits), 69 bytes captured (552 bits)
[+] Ethernet II, Src: Hilscher_2b:41:ff (00:02:a2:2b:41:ff), Dst: Intel_39:52:10 (90:e2:ba:39:52:10)
[+] Internet Protocol Version 4, Src: 172.16.252.10 (172.16.252.10), Dst: 172.16.252.1 (172.16.252.1)
[+] Transmission Control Protocol, Src Port: scp-config (10001), Dst Port: 58203 (58203), Seq: 1, Ack: 6, Len: 15
    Source port: scp-config (10001)
    Destination port: 58203 (58203)
    [Stream index: 3]
    Sequence number: 1 (relative sequence number)
    [Next sequence number: 16 (relative sequence number)]
    Acknowledgement number: 6 (relative ack number)
    Header length: 20 bytes
    [+] Flags: 0x18 (PSH, ACK)
        window size value: 2915
        [Calculated window size: 2915]
        [window size scaling factor: -2 (no window scaling used)]
    [+] Checksum: 0x6fb9 [validation disabled]
    [SEQ/ACK analysis]
[+] Data (15 bytes)
    Data: 30363235302f362e302e322e33300d
    [Length: 15]
0000 90 e2 ba 39 52 10 00 02 a2 2b 41 ff 08 00 45 00  ...9R... .+A...E.
0010 00 37 00 02 00 00 ff 06 6b 91 ac 10 fc 0a ac 10  .7.... k.....
0020 fc 01 27 11 e3 5b 00 00 19 6f 58 c6 fc 7b 50 18  ...'...[. .ox...{P.
0030 0b 63 6f b9 00 00 30 36 32 35 30 2f 36 2e 30 2e  .co...06 250/6.0.
0040 32 2e 33 30 0d 2.30.
    
```

Example with a Numeric Response

This is a TCP example with a numeric response as a string; the RPA command reports the value 1105.

Output: 80 52 50 41 20

Input: 31 31 30 35 0d

TCP Stream*				
	Prefix	Command	Response	Terminator
Output	80	52 50 41 ("RPA")		20
Input			31 31 30 35 ("1105")	0d

A table is provided to illustrate the parts of the byte sequence only. The byte sequence must be transmitted as a stream of bytes shown in the Output/Input strings above the table (i.e., no pause or null for the blank cells).

Output:

```

⊞ Frame 706: 59 bytes on wire (472 bits), 59 bytes captured (472 bits)
⊞ Ethernet II, Src: Intel_39:52:10 (90:e2:ba:39:52:10), Dst: Hilscher_2b:41:ff (00:02:a2:2b:41:ff)
⊞ Internet Protocol Version 4, Src: 172.16.252.1 (172.16.252.1), Dst: 172.16.252.10 (172.16.252.10)
⊞ Transmission Control Protocol, Src Port: 51490 (51490), Dst Port: scp-config (10001), Seq: 1, Ack: 1, Len: 5
  Source port: 51490 (51490)
  Destination port: scp-config (10001)
  [Stream index: 11]
  Sequence number: 1 (relative sequence number)
  [Next sequence number: 6 (relative sequence number)]
  Acknowledgement number: 1 (relative ack number)
  Header length: 20 bytes
  ⊞ Flags: 0x18 (PSH, ACK)
  Window size value: 64240
  [Calculated window size: 64240]
  [Window size scaling factor: -2 (no window scaling used)]
  ⊞ Checksum: 0x504d [validation disabled]
  ⊞ [SEQ/ACK analysis]
⊞ Data (5 bytes)
  Data: 8052504120
  [Length: 5]

0000 00 02 a2 2b 41 ff 90 e2 ba 39 52 10 08 00 45 00  ...+A... .9R...E.
0010 00 2d 02 b2 40 00 80 06 00 00 ac 10 fc 01 ac 10  ..-..@... ..
0020 fc 0a c9 22 27 11 a2 01 3e 19 00 00 19 85 50 18  ...".... >.....P.
0030 fa f0 50 4d 00 00 80 52 50 41 20                ..PM...R PA
  
```

Input:

```

⊞ Frame 707: 60 bytes on wire (480 bits), 60 bytes captured (480 bits)
⊞ Ethernet II, Src: Hilscher_2b:41:ff (00:02:a2:2b:41:ff), Dst: Intel_39:52:10 (90:e2:ba:39:52:10)
⊞ Internet Protocol Version 4, Src: 172.16.252.10 (172.16.252.10), Dst: 172.16.252.1 (172.16.252.1)
⊞ Transmission Control Protocol, Src Port: scp-config (10001), Dst Port: 51490 (51490), Seq: 1, Ack: 6, Len: 5
  Source port: scp-config (10001)
  Destination port: 51490 (51490)
  [Stream index: 11]
  Sequence number: 1 (relative sequence number)
  [Next sequence number: 6 (relative sequence number)]
  Acknowledgement number: 6 (relative ack number)
  Header length: 20 bytes
  ⊞ Flags: 0x18 (PSH, ACK)
  Window size value: 2915
  [Calculated window size: 2915]
  [Window size scaling factor: -2 (no window scaling used)]
  ⊞ Checksum: 0xfbf7 [validation disabled]
  ⊞ [SEQ/ACK analysis]
⊞ Data (5 bytes)
  Data: 313130350d
  [Length: 5]

0000 90 e2 ba 39 52 10 00 02 a2 2b 41 ff 08 00 45 00  ...9R... .+A...E.
0010 00 2d 00 94 00 00 ff 06 6b 09 ac 10 fc 0a ac 10  ..-..... k.....
0020 fc 01 27 11 c9 22 00 00 19 85 a2 01 3e 1e 50 18  ...".... >.....P.
0030 0b 63 fb f7 00 00 31 31 30 35 0d 00                .c....11 05.
  
```

Example of Assigning a Variable

This is a TCP example of assigning a numeric value to a variable: a=400.

Output: 80 61 3D 34 30 30 20

Input: 31 31 30 35 0d

TCP Stream*				
	Prefix	Command	Response	Terminator
Output	80	61 3D 34 30 30 ("a=400")		20
Input	N/A - See Input figure below			

A table is provided to illustrate the parts of the byte sequence only. The byte sequence must be transmitted as a stream of bytes shown in the Output/Input strings above the table (i.e., no pause or null for the blank cells).

Output:

No.	Time	Source	Destination
1	2016-11-22 14:00:32.647792	172.16.252.1	172.16.252.10
2	2016-11-22 14:00:32.752392	172.16.252.10	172.16.252.1

```

Frame 1: 61 bytes on wire (488 bits), 61 bytes captured (488 bits)
Ethernet II, Src: Intel_39:52:10 (90:e2:ba:39:52:10), Dst: Hilscher_2b:41:ff (00:02:a2:2b:41:ff)
Internet Protocol Version 4, Src: 172.16.252.1 (172.16.252.1), Dst: 172.16.252.10 (172.16.252.10)
Transmission Control Protocol, Src Port: 60035 (60035), Dst Port: scp-config (10001), Seq: 1, Ack: 1, Len: 7
Data (7 bytes)
  Data: 80613d34303020
    [Length: 7]

0000  00 02 a2 2b 41 ff 90 e2 ba 39 52 10 08 00 45 00  ...+A... .9R...E.
0010  00 2f 00 e3 40 00 80 06 00 00 ac 10 fc 01 ac 10  ../.@... .....
0020  fc 0a ea 83 27 11 a5 82 4a 68 00 00 19 85 50 18  ....'... Jh...P.
0030  fa f0 50 4f 00 00 80 61 3d 34 30 30 20          ..PO...a =400
    
```

Input:

The following figure shows the SmartMotor ACKnowledgement back to the PC/master. However, it doesn't contain any data to respond to; it is just to keep the TCP connection alive.

No.	Time	Source	Destination	Protocol	Length	Info
1	2016-11-22 14:00:32.647792	172.16.252.1	172.16.252.10	TCP	61	60035 > scp-config [PSH, ACK] Seq=1 Ack=1 win=64240 Len=7
2	2016-11-22 14:00:32.752392	172.16.252.10	172.16.252.1	TCP	60	scp-config > 60035 [ACK] Seq=1 Ack=8 win=2913 Len=0
3	2016-11-22 14:00:59.997567	Hilscher_2b:41:ff	Broadcast	ARP	60	who has 172.16.252.10? Tell 0.0.0.0

```

Frame 2: 60 bytes on wire (480 bits), 60 bytes captured (480 bits)
Ethernet II, Src: Hilscher_2b:41:ff (00:02:a2:2b:41:ff), Dst: Intel_39:52:10 (90:e2:ba:39:52:10)
Internet Protocol Version 4, Src: 172.16.252.10 (172.16.252.10), Dst: 172.16.252.1 (172.16.252.1)
Transmission Control Protocol, Src Port: scp-config (10001), Dst Port: 60035 (60035), Seq: 1, Ack: 8, Len: 0

0000  90 e2 ba 39 52 10 00 02 a2 2b 41 ff 08 00 45 00  ...9R... .+A...E.
0010  00 28 00 93 00 00 ff 06 6b 0f ac 10 fc 0a ac 10  ..(. .... k.....
0020  fc 01 27 11 ea 83 00 00 19 85 a5 82 4a 6f 50 10  .... ..JOP.
0030  0b 61 39 3a 00 00 00 00 00 00 00 00          ..a9:....
    
```

Example of Program Downloading, Running and Uploading

This is a TCP example of downloading, running and uploading the following program:

```
' My test program

WHILE 1
    PRINT2("Hi there Ethernet host",#13)
    WAIT=1000
LOOP

END
```

Downloading the Program

Output:	80 4C 4F 41 44 20	LOAD command sent to motor
Input:	06	ACK from motor
Output:	24 36 30 30 30 30 30 30 31 31 36 44 30 30 30 30 34 30 30 30 30 30 30 30 30 30 30 30 24 57 30 30 33	32 character block of program download
Input:	06	ACK from motor
Output:	43 4C 45 20 31 0A 50 52 49 4E 54 32 28 22 48 69 20 74 68 65 72 65 20 45 74 68 65 72 6E 65 74 20	32 character block of program download
Input:	06	ACK from motor
Output:	68 6F 73 74 22 2C 23 31 33 29 0A 57 41 49 54 3D 31 30 30 30 0A 24 4C 30 30 30 30 50 0A 45 4E 44	32 character block of program download
Input:	06	ACK from motor
Output:	0A FF 24 74 65 73 74 20 65 74 68 65 72 6E 65 74 2E 73 6D 78 00 20 20 20 20 20 10 0B 16 13 07	32 character block of program download
Input:	06	ACK from motor
Output:	02 87 00 00 00 59 08	Remaining character block of program down- load
Output:	FF FF 20	Output, but no reply expected
Output:	80 52 43 4B 53 20	RCKS command
Input:	30 30 30 30 30 30 20 30 30 31 31 36 44 20 50 0D	Two checksum values and P (pass)

SMI Serial Data Analyzer (shows Output and Input)

```
>80 4C 4F 41 44 20 | ..LOAD..
>06 | ..
>24 36 30 30 30 30 30 30 31 31 36 44 30 30 30 30 34 30 30 30 30 | $600000116D000040000
30 30 30 30 30 30 30 30 24 57 30 30 33 06 43 4C 45 20 31 0A 50 | 0000000$W003..CLE..1..P
52 49 4E 54 32 28 22 48 69 20 74 68 65 72 65 20 45 74 68 65 | RINT2("Hi..there..Ethe
72 6E 65 74 20 06 68 6F 73 74 22 2C 23 31 33 29 0A 57 41 49 | rnet...host",#13)..WAI
54 3D 31 30 30 30 0A 24 4C 30 30 30 30 50 0A 45 4E 44 06 0A | T=1000..$L0000P..END....
FF 24 74 65 73 74 20 65 74 68 65 72 6E 65 74 2E 73 6D 78 00 | ..$test..ethernet.smx..
20 20 20 20 20 20 10 0B 16 13 07 06 02 87 00 00 00 59 08 | .....Y..
>FF FF 20 | .....
>80 52 43 4B 53 20 | ..RCKS..
>30 30 30 30 30 30 20 30 30 31 31 36 44 20 50 0D | 000000..00116D..P..
```

Running the Program

Output:	80 52 55 4E 20	RUN command
	48 69 20 74 68 65 72 65 20 45 74 68 65 72 6E 65	
	74 20 68 6F 73 74 0D	
Input:	...	"Hi there..." messages from program loop
	48 69 20 74 68 65 72 65 20 45 74 68 65 72 6E 65	
	74 20 68 6F 73 74 0D	
Output:	80 45 4E 44 20	END command

SMI Serial Data Analyzer (shows Output and Input)

```

>80 52 55 4E 20 | ..RUN..
>48 69 20 74 68 65 72 65 20 45 74 68 65 72 6E 65 74 20 68 6F | Hi..there..Ethernet..ho
73 74 0D | st..
>48 69 20 74 68 65 72 65 20 45 74 68 65 72 6E 65 74 20 68 6F | Hi..there..Ethernet..ho
73 74 0D | st..
>48 69 20 74 68 65 72 65 20 45 74 68 65 72 6E 65 74 20 68 6F | Hi..there..Ethernet..ho
73 74 0D | st..
>48 69 20 74 68 65 72 65 20 45 74 68 65 72 6E 65 74 20 68 6F | Hi..there..Ethernet..ho
73 74 0D | st..
>80 45 4E 44 20 | ..END..
    
```

Uploading the Program

Output:	80 55 50 4C 4F 41 44 20	UPLOAD command sent to motor
Input:	57 48 49 4C 45 20 31 0A	16 character block of upload from motor
Output:	06	ACK from host
Input:	50 52 49 4E 54 32 28 22	16 character block of upload from motor
Output:	06	ACK from host
Input:	48 69 20 74 68 65 72 65	16 character block of upload from motor
Output:	06	ACK from host
Input:	20 45 74 68 65 72 6E 65	16 character block of upload from motor
Output:	06	ACK from host
Input:	74 20 68 6F 73 74 22 2C	16 character block of upload from motor
Output:	06	ACK from host
Input:	23 31 33 29 0A 57 41 49	16 character block of upload from motor
Output:	06	ACK from host
Input:	54 3D 31 30 30 30 0A 4C	16 character block of upload from motor
Output:	06	ACK from host
Input:	4F 4F 50 0A 45 4E 44 0A	16 character block of upload from motor

SMI Serial Data Analyzer (shows Output and Input)

```

>80 55 50 4C 4F 41 44 20 | ..UPLOAD..
>57 48 49 4C 45 20 31 0A | WHILE..1..
>06 | ..
>50 52 49 4E 54 32 28 22 | PRINT2 ("
>06 | ..
>48 69 20 74 68 65 72 65 | Hi..there
>06 | ..
>20 45 74 68 65 72 6E 65 | ..Etherne
>06 | ..
>74 20 68 6F 73 74 22 2C | t..host",
>06 | ..
>23 31 33 29 0A 57 41 49 | #13)..WAI
>06 | ..
>54 3D 31 30 30 30 0A 4C | T=1000..L
>06 | ..
>4F 4F 50 0A 45 4E 44 0A | OOP..END..
    
```

Troubleshooting

The following table provides troubleshooting information for solving common problems. For additional support resources, see the Moog Animatics Support page at:

<http://www.animatics.com/support.html>

Issue	Cause	Solution
Communication and Control Issues		
Motor control power light does not illuminate.	Control power is off, disconnected or incorrectly wired.	Check that control power is connected to the proper pins and turned on. For connection details, see Connecting the System on page 12.
	Motor has routed drive power through drive-enable pins.	Ensure cabling is correct and drive power is not being delivered through the 15-pin connector.
	Motor is equipped with the DE option.	To energize control power, apply 24-48 VDC to pin 15 and ground to pin 14.
Motor does not communicate with SMI.	Transmit, receive or ground pins are not connected correctly.	Ensure that transmit, receive and ground are all connected properly to the host PC.
	Motor program is stuck in a continuous loop or is disabling communications.	To prevent the program from running on power up, use the Communications Lockup Wizard located on the SMI software Communications menu.
Motor not detected or not communicating through TCP (Ethernet port in SMI).	IP address and/or net-mask not set.	See IPCTL command, or check DHCP server.
	Feature disabled	See ETHCTL(100,<value>) command.
Motor disconnects from SMI sporadically.	COM port buffer settings are too high.	Adjust the COM port buffer settings to their lowest values.
	Poor connection on serial cable.	Check the serial cable connections and/or replace it.
	Power supply unit (PSU) brownout.	PSU may be too high-precision and/or undersized for the application, which causes it to brown-out during motion. Make moves less aggressive, increase PSU size or change to a linear unregulated power supply.
Red PWR SERVO light illuminated.	Critical fault.	To discover the source of the fault, use the Motor View tool located on the SMI software Tools menu.
Common Faults		
Bus voltage fault.	Bus voltage is either too high or too low for operation.	Check servo bus voltage. If motor uses the DE power option, ensure that both drive and control power are connected.
Overcurrent occurred.	Motor intermittently drew more than its rated level of current. Does not cease motion.	Consider making motion less abrupt with softer tuning parameters or acceleration profiles.
Excessive temperature fault.	Motor has exceeded temperature limit of 85°C. Motor will remain unresponsive until it cools down below 80°C.	Motor may be undersized or ambient temperature is too high. Consider adding heat sinks or forced air cooling to the system.

Troubleshooting

Issue	Cause	Solution
Excessive position error.	The motor's commanded position and actual position differ by more than the user-supplied error limit.	Increase error limit, decrease load or make movement less aggressive.
Historical positive/negative hardware limit faults.	A limit switch was tripped in the past.	Clear errors with the ZS command.
	Motor does not have limit switches attached.	Configure the motor to be used without limit switches by setting their inputs as general use.
Programming and SMI Issues		
Several commands not recognized during compiling.	Compiler default firmware version set incorrectly.	Use the Compiler default firmware version option in the SMI software Compile menu to select a default firmware version closest to the motor's firmware version. In the SMI software, view the motor's firmware version by right-clicking the motor and selecting Properties.

PN: SC80100017-001, Rev. B
Ethernet Serial Encapsulation