

# 2013

## HOCHLEISTUNGSFRÄSER



Vielfalt vereint

Dynamik in allen Dimensionen



SOFTMILL ungleicher Drill	Z	Drall	Beschichtung coated	Art.-Nr. Art.-No.	STAHL steel	HSC	HRc 56	INOX stainless steel	GUSS cast iron	Titan Inconell Hasteloy	ALU aluminium	NE non ferrous	Kunststoff plastic	Graphit graphite	Seite page
------------------------------	---	-------	---------------------	----------------------	----------------	-----	-----------	----------------------------	-------------------	-------------------------------	------------------	----------------------	-----------------------	---------------------	---------------

ungleiche Drallsteigung + ungleiche Schneidenteilung

	4	35° 38°	ZX4	KF100	■ ■				■ ■	■ ■					6
	3	41°/43° 45°	ZX4	KF101	■ ■				■ ■	■ ■					6
	4	36° 38°	ZX3	KF102			■ ■								7
	4	40° 42°	ohne	KF103							■ ■	■			7
	6	44°/45° 46°	ZX4	KF110	■ ■		■ ■	■ ■	■ ■	■ ■					8

UNIVERSAL 30° (WERKNORM)	Z	Drall	Beschichtung coated	Art.-Nr. Art.-No.	STAHL steel	HSC	HRc 70	INOX stainless steel	GUSS cast iron	Titan Inconell Hasteloy	ALU aluminium	NE non ferrous	Kunststoff plastic	Graphit graphite	Seite page
-----------------------------	---	-------	---------------------	----------------------	----------------	-----	-----------	----------------------------	-------------------	-------------------------------	------------------	----------------------	-----------------------	---------------------	---------------

VHM-Schaftfräser 30° - Kempf Norm - Ø 2,0 bis Ø 20,0

	2	30°	ohne	KF342	■			■	■	■	■	■	■	■	9
	3	30°	ohne	KF343	■			■	■	■	■	■	■	■	9

UNIVERSAL 30° LANG + EXTRA LANG	Z	Drall	Beschichtung coated	Art.-Nr. Art.-No.	STAHL steel	HSC	HRc 70	INOX stainless steel	GUSS cast iron	Titan Inconell Hasteloy	ALU aluminium	NE non ferrous	Kunststoff plastic	Graphit graphite	Seite page
------------------------------------	---	-------	---------------------	----------------------	----------------	-----	-----------	----------------------------	-------------------	-------------------------------	------------------	----------------------	-----------------------	---------------------	---------------

VHM-Schaftfräser 30° - Baulänge DIN 6527 Lang und EXTRA LANG - Ø 2,0 bis Ø 20,0

	2	30°	ZX4	KF322	■			■	■	■	■	■	■	■	10
	3	30°	ZX4	KF323	■			■	■	■	■	■	■	■	10
	4	30°	ZX4	KF324	■			■	■	■	■	■	■	■	10
	2	30°	ZX4	KF392	■			■	■	■	■	■	■	■	11
	3	30°	ZX4	KF393	■			■	■	■	■	■	■	■	11
	4	30°	ZX4	KF394	■			■	■	■	■	■	■	■	11

UNIVERSAL 45° MINI + LANG	Z	Drall	Beschichtung coated	Art.-Nr. Art.-No.	STAHL steel	HSC	HRc 70	INOX stainless steel	GUSS cast iron	Titan Inconell Hasteloy	ALU aluminium	NE non ferrous	Kunststoff plastic	Graphit graphite	Seite page
------------------------------	---	-------	---------------------	----------------------	----------------	-----	-----------	----------------------------	-------------------	-------------------------------	------------------	----------------------	-----------------------	---------------------	---------------

VHM-Schaftfräser 45° - Werknorm (MINI) und Baulänge DIN 6527 Lang - Ø 0,5 bis Ø 20,0

	3	45°	ZX3	KF300	■ ■			■	■ ■	■	■	■			12
--	---	-----	-----	-------	-----	--	--	---	-----	---	---	---	--	--	----

SCHLICHTFRÄSER UNIVERSAL	Z	Drall	Beschichtung coated	Art.-Nr. Art.-No.	STAHL steel	HSC	HRc 70	INOX stainless steel	GUSS cast iron	Titan Inconell Hasteloy	ALU aluminium	NE non ferrous	Kunststoff plastic	Graphit graphite	Seite page
-----------------------------	---	-------	---------------------	----------------------	----------------	-----	-----------	----------------------------	-------------------	-------------------------------	------------------	----------------------	-----------------------	---------------------	---------------

VHM-Schlichtfräser 45°/50° - Baulänge DIN 6527 Lang und EXTRA LANG - Ø 4,0 bis Ø 25,0

	6-8	45°	ZX3	KF308	■ ■			■	■ ■	■	■	■			13
	6-8	45°	ZX3	KF309	■ ■			■	■ ■	■	■	■			13

Zeichenerklärung:





















- = Werkzeug gut geeignet
- ■ = Werkzeug hervorragend geeignet (speziell für diesen Werkstoff entwickelt)

RADIUSFRÄSER UNIVERSAL				STAHLeel	HSC	HRC 70	INOX stainless steel	GUSS cast iron	Titan Inconell Hasteloy	ALU aluminium	NE non ferrous	Kunststoff plastic	Graphit graphite	Seite page
VHM-Radiusfräser mit 2, 3 oder 4 Schneiden - kurze und extra lange Ausführung														
	2/3/4	30°	ohne o. ZX1	KFB...	■		■	■	■	■	■	■	■	35
	2/3/4	30°	ohne o. ZX1	KFB...	■		■	■	■	■	■	■	■	35
ALU-FRÄSER KUNSTSTOFFE				STAHLeel	HSC	HRC 70	INOX stainless steel	GUSS cast iron	Titan Inconell Hasteloy	ALU aluminium	NE non ferrous	Kunststoff plastic	Graphit graphite	Seite page
VHM-Schaftfräser für Alu, Kunststoffe und NE-Metalle - Ø 3,0 bis Ø 20,0														
	2	45°	ohne	KF302						■ ■	■ ■	■		14
	2	45°	ohne	KF396						■ ■	■ ■			14
	3	45°	ohne	KF318						■ ■	■ ■	■		15
VHM-HSC-Fräser mit geläppter Spannutt für Alu, Kunststoffe und NE-Metalle - Ø 2,0 bis Ø 20,0														
	1	30°	ohne	KF535						■ ■		■ ■		16
	2	30°	ohne	KF536						■ ■		■ ■		17
	3	30°	ohne	KF537						■ ■		■ ■		17
VHM-HSC-Fräser mit Diamantverzahnung für GFK, CFK und Kunststoffe - Ø 2,0 bis Ø 12,0														
			ohne	KF630								■ ■	■	18
			ohne	KF631								■ ■	■	18
			ohne	KF632								■ ■	■	19
PKD-Schaftfräser ALU + NE-Metalle				STAHLeel	HSC	HRC 70	INOX stainless steel	GUSS cast iron	Titan Inconell Hasteloy	ALU aluminium	NE non ferrous	GFK CFK	Graphit graphite	Seite page
PKD-Schaftfräser für Aluminium und NE-Metalle														
	2	0°	ohne	KF910						■ ■	■ ■	■ ■	■ ■	20
	2	2°+1	ohne	KF915						■ ■	■ ■	■ ■	■ ■	20
	2	2°+1	ohne	KF920						■ ■	■ ■	■ ■	■ ■	21
	2	0°	ohne	KFB910						■ ■	■ ■	■ ■	■ ■	21
GRAPHIT-FRÄSER KUNSTSTOFFE				STAHLeel	HSC	HRC 70	INOX stainless steel	GUSS cast iron	Titan Inconell Hasteloy	ALU aluminium	NE non ferrous	GFK CFK	Graphit graphite	Seite page
VHM-Schaftfräser mit Diamantbeschichtung für Graphit														
	2	30°	DIA	KF700							■ ■	■ ■	■ ■	22
	2	30°	DIA	KFB700							■ ■	■ ■	■ ■	23

Hinweis: Diamantbeschichtete VHM-Fräser ab Ø 0,3 bis Ø 3,0 finden Sie auf den Seiten 28 bis 33.

Zeichenerklärung:











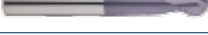
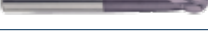

- = Werkzeug gut geeignet
- ■ = Werkzeug hervorragend geeignet (speziell für diesen Werkstoff entwickelt)

MICRO-FRÄSER AB Ø 0,10	Z	Drall	Beschichtung coated	Art.-Nr. Art.-No.	STAHL steel	HSC	HRC 56	INOX stainless steel	GUSS cast iron	Titan Inconel Hasteloy	ALU aluminium	NE non ferrous	Kunststoff plastic	Graphit graphite	Seite page
VHM-Micro-Schaftfräser 30° - Ø 0,1 bis Ø 3,0 - Arbeitstiefe 1,5 x Ø und 2-3 x Ø															
	2	30°	ohne	KF350 - KF351	■				■ ■		■ ■	■ ■	■ ■		28-29
	2	30°	ZX3	KF350 - KF351	■ ■		■	■ ■	■ ■	■ ■	■	■			28-29
	2	30°	DIA	KF350 - KF351							■ ■		■ ■	■ ■	28-29
VHM-Micro-Schaftfräser 30° - Ø 0,4 bis Ø 3,0 - Arbeitstiefe 5 x Ø und 8 x Ø															
	2	30°	ohne	KF352 - KF353	■				■ ■		■ ■	■ ■	■ ■		30
	2	30°	ZX3	KF352 - KF353	■ ■		■	■ ■	■ ■	■ ■	■	■			30
	2	30°	DIA	KF352 - KF353							■ ■		■ ■	■ ■	30
VHM-Micro-Schaftfräser 30° - Ø 0,4 bis Ø 2,5 - Arbeitstiefe bis 15mm															
	2	30°	ohne	KF354	■				■ ■		■ ■	■ ■	■ ■		31
	2	30°	ZX3	KF354	■ ■		■	■ ■	■ ■	■ ■	■	■			31
	2	30°	DIA	KF354							■ ■		■ ■	■ ■	31
VHM-Micro-Einzahnfräser - Ø 0,50 bis Ø 3,00 - Arbeitstiefe bis 3 x Ø															
	1	30°	ohne	KF535							■ ■		■ ■		16
MICRO-FRÄSER RADIUSFRÄSER															
VHM-Micro-Radiusfräser 30° - Ø 0,1 bis Ø 3,0 - Arbeitstiefe 1,5 x Ø und 2-3 x Ø															
	2	30°	ohne	KFB350 KFB351	■				■ ■		■ ■	■ ■	■ ■		32
	2	30°	ZX3	KFB350 KFB351	■ ■		■	■ ■	■ ■	■ ■	■	■			32
	2	30°	DIA	KFB350 KFB351							■ ■		■ ■	■ ■	32
VHM-Micro-Radiusfräser 30° - Ø 0,4 bis Ø 2,5 - Arbeitstiefe bis 15mm															
	2	30°	ohne	KFB352	■				■ ■		■ ■	■ ■	■ ■		33
	2	30°	ZX3	KFB352	■ ■		■	■ ■	■ ■	■ ■	■	■			33
	2	30°	DIA	KFB352							■ ■		■ ■	■ ■	33
VHM-Micro-Kugelfräser 30° - Ø 0,8 bis Ø 5,0															
	2	30°	ZX3	KFB510	■ ■		■	■ ■		■ ■					39
VHM-Micro-1/4-Kreis Konkavfräser															
	2	0°	ohne	KF616	■			■	■		■	■	■		34
UNIVERSAL-TOOL 60° - 90° - 120°															
VHM-Werkzeug zum Fräsen, Bohren und Senken mit nur einem Werkzeug															
	2	30°	ohne o. ZX3	KF620	■			■	■	■	■	■	■		26
	2	30°	ohne o. ZX3	KF621	■			■	■	■	■	■	■		27
	2	30°	ohne o. ZX3	KF622	■			■	■	■	■	■	■		27

Zeichenerklärung:

- = Werkzeug gut geeignet
- ■ = Werkzeug hervorragend geeignet (speziell für diesen Werkstoff entwickelt)

# Inhaltsverzeichnis

KOPIERFRÄSER HARTFRÄSER	Z	Drall	Beschichtung coated	Art.-Nr. Art.-No.	STAHL	HSC	HRC	INOX	GUSS	Titan	ALU	NE	Kunststoff	Graphit	Seite page
					steel		<65	stainless steel	cast iron	Inconel Hasteloy	aluminium	non ferrous	plastic	graphite	
<b>VHM-HSC-Kopierfräser</b>															
	2	30°	ZX3	KFB502	■	■	■		■						36
	2	30°	ZX3	KFB503	■	■	■		■						36
	2	15°	ZX3	KFB516	■	■	■								37
	2	30°	ZX3	KFB506	■	■	■		■						38
	2	30°	ZX3	KFB512	■	■	■		■						40
	4	30°	ZX3	KFB514	■	■	■		■						40
	4	30°	ZX3	KFB504	■	■	■		■						39
<b>VHM-HSC-Schaftfräser</b>															
	2	30°	ZX3	KF502	■		■		■						44
	4	30°	ZX3	KF504	■	■	■		■						45
	6-8	45°	ZX3	KF600 KF602	■	■	■								41
<b>VHM-HSC-Schaftfräser mit Eckenradius</b>															
	2	30°	ZX3	KF506	■		■		■						42
	4	30°	ZX3	KF508 KF509	■		■		■						43
<b>SCHRUPPFRÄSER Stahl/Alu/Universell</b>															
Z	Drall	Beschichtung coated	Art.-Nr. Art.-No.	STAHL	HSC	HRC	INOX	GUSS	Titan	ALU	NE	Kunststoff	Graphit	Seite page	
steel						<65	stainless steel	cast iron	Inconel Hasteloy	aluminium	non ferrous	plastic	graphite		
<b>VHM-Schrupp-Schlichtfräser</b>															
	3-4	30°	ZX5	KF306	■		■	■	■	■	■	■	■	■	25
<b>VHM-Schruppfräser und VHM-Schruppfräser mit Innenkühlung</b>															
	3-5	20°	ZX3	KF310 KF311	■		■		■						24
	3-4	20°	ZX3	KFB311	■		■		■						24
	4	30°	ZX4	KF319	■		■	■	■						25
<b>VHM-ALU-Schruppfräser und VHM-ALU-Schruppfräser mit Innenkühlung</b>															
	3	30°	ohne	KF312						■	■	■	■		15
	3	30°	ohne	KF313						■	■	■	■		15
KEMPF BESCHICHTUNGSVARIANTEN SEITE 34 / Kempf coating types page 34															
ANFRAGEBOGEN FÜR VHM-SONDERFRÄSER SEITE 46 / questionnaire for special solid carbide end mills page 46															

Zeichenerklärung: ■ = Werkzeug gut geeignet  
 ■■ = Werkzeug hervorragend geeignet (speziell für diesen Werkstoff entwickelt)

## SOFTMILL TYP UNI

### 4-Schneidig

### KF100 - ZX4



Einsatzgebiete: Universell einsetzbar, mit 35°/38° Spirale optimal zum Nuten, Schruppen und Schlichten in Stahl, hochlegiertem Stahl und gehärtetem Stahl bis 1600N/mm<sup>2</sup>.

application: Universal use, due to 35°/38° helix particularly suitable for grooving, roughing and finishing of steel, high-alloy steel and hardened steel up to 1600N/mm<sup>2</sup>



* Kantenschutz ***					
Ø 4 - Ø 5	Ø 6 - Ø 8	Ø 10 - Ø 12	Ø 16	Ø 20	Ø 25
0,1 x 45°	0,150 x 45°	0,200 x 45°	0,350 x 45°	0,450 x 45°	0,600 x 45°

- ab Lager / ex stock
- kurzfristig / on short notice
- Lieferzeit auf Anfrage / delivery time upon request

d1	d2	d3	l1	l2	l3	Artikel-Nr. (code no.)	Preis Euro / je	Artikel-Nr. (code no.)	Preis Euro / je
h10	h6					Schaft HB	Schaft HB	Schaft HA	Schaft HA
mm	mm	mm	mm	mm	mm				
4,00	6,0	3,7	57,0	11,0	18,0	KF100040ZX4B	17,20	KF100040ZX4	15,80
5,00	6,0	4,7	57,0	13,0	18,0	KF100050ZX4B	17,20	KF100050ZX4	15,80
6,00	6,0	5,5	57,0	13,0	21,0	KF100060ZX4B	20,80	KF100060ZX4	19,60
8,00	8,0	7,5	63,0	19,0	27,0	KF100080ZX4B	28,80	KF100080ZX4	27,60
10,00	10,0	9,2	72,0	22,0	32,0	KF100100ZX4B	42,40	KF100100ZX4	40,80
12,00	12,0	11,2	83,0	26,0	38,0	KF100120ZX4B	54,40	KF100120ZX4	52,80
16,00	16,0	15,0	92,0	32,0	44,0	KF100160ZX4B	95,20	KF100160ZX4	91,20
20,00	20,0	19,0	104,0	38,0	54,0	KF100200ZX4B	144,80	KF100200ZX4	141,60
25,00	25,0	23,5	121,0	45,0	65,0	KF100250ZX4B	230,40	KF100250ZX4	224,00

## SOFTMILL TYP UNI

### 3-Schneidig

### KF101 - ZX4



Einsatzgebiete: Mit 41°/43°/45° Spirale universell einsetzbar zum Nuten, Schruppen und Schlichten in Stahl, hochlegiertem Stahl und gehärtetem Stahl bis 1400N/mm<sup>2</sup> (44 HRC). Als 3-Schneider mit größerem Spanraum auch für extrem hohe Schnitttiefen einsetzbar.

application: Due to 41°/43°/45° helix universal use, well suited for grooving, roughing and finishing operations in steel, high-alloy steel and hardened steel up to 1400N/mm<sup>2</sup> (44HRC). This end mill with 3 flutes and additional chip space can be used for operations with extrem cutting depths.



* Kantenschutz ***		
Ø 3 - Ø 6	Ø 8 - Ø 10	Ø 12 - Ø 20
0,05 x 45°	0,100 x 45°	0,150 x 45°

- ab Lager / ex stock
- kurzfristig / on short notice
- Lieferzeit auf Anfrage / delivery time upon request

d1	d2	d3	l1	l2	l3	Artikel-Nr. (code no.)	Preis Euro / je	Artikel-Nr. (code no.)	Preis Euro / je
h10	h6					Schaft HB	Schaft HB	Schaft HA	Schaft HA
mm	mm	mm	mm	mm	mm				
3,00	6,0	2,7	57,0	8,0	15,0	KF101030ZX4B	20,00	KF101030ZX4	18,60
4,00	6,0	3,7	57,0	11,0	18,0	KF101040ZX4B	20,00	KF101040ZX4	18,60
5,00	6,0	4,7	57,0	13,0	18,0	KF101050ZX4B	20,00	KF101050ZX4	18,60
6,00	6,0	5,5	57,0	13,0	21,0	KF101060ZX4B	24,80	KF101060ZX4	23,40
8,00	8,0	7,5	63,0	19,0	27,0	KF101080ZX4B	33,60	KF101080ZX4	32,20
10,00	10,0	9,2	72,0	22,0	32,0	KF101100ZX4B	50,00	KF101100ZX4	48,00
12,00	12,0	11,2	83,0	26,0	38,0	KF101120ZX4B	64,40	KF101120ZX4	62,40
16,00	16,0	15,0	92,0	32,0	44,0	KF101160ZX4B	110,40	KF101160ZX4	107,00
20,00	20,0	19,0	104,0	38,0	54,0	KF101200ZX4B	167,80	KF101200ZX4	164,40

## SOFTMILL TYP INOX

## 4-Schneidig

## KF102 - ZX3

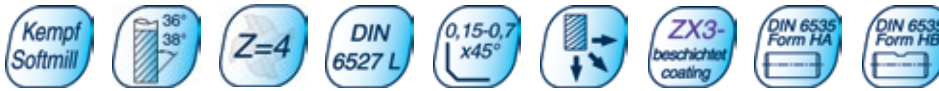

Einsatzgebiete: Hochleistungsfräser besonders gut geeignet zur Bearbeitung von VA-Stählen bzw. rostfreien Stählen mit verbesserter Spanabfuhr. Einsetzbar zum Schlichten, Schrupp-Schlichten und Schruppen mit einem Werkzeug.

application: High-performance end mill with improved chip removal well suited to machine VA-steels and stainless steels, for fine finishing, finishing, rough finishing and roughing operations with but one single tool.



* Kantenschutz ***						
Ø 6	Ø 8	Ø 10	Ø 12	Ø 16	Ø 20	Ø 25
0,2 x 45°	0,25 x 45°	0,30 x 45°	0,35 x 45°	0,50 x 45°	0,60 x 45°	0,75 x 45°

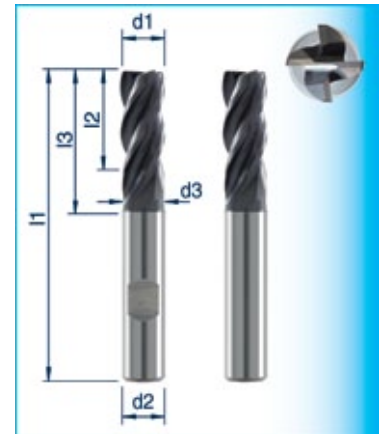

- ab Lager / ex stock
- kurzfristig / on short notice
- Lieferzeit auf Anfrage / delivery time upon request

d1	d2	d3	l1	l2	l3	Artikel-Nr.	Preis	Artikel-Nr.	Preis
h10	h6					(code no.)	Euro / je	(code no.)	Euro / je
mm	mm	mm	mm	mm	mm	Schaft HB	Schaft HB	Schaft HA	Schaft HA
4,00	6,0	3,7	54,0	8,0	15,0	KF102040ZX3B	• 23,40	KF102040ZX3	• 22,00
5,00	6,0	4,7	54,0	9,0	15,0	KF102050ZX3B	• 23,40	KF102050ZX3	• 22,00
6,00	6,0	5,5	57,0	13,0	21,0	KF102060ZX3B	• 27,40	KF102060ZX3	• 25,80
8,00	8,0	7,5	63,0	19,0	27,0	KF102080ZX3B	• 37,00	KF102080ZX3	• 35,80
10,00	10,0	9,2	72,0	22,0	32,0	KF102100ZX3B	• 55,60	KF102100ZX3	• 53,60
12,00	12,0	11,2	83,0	26,0	38,0	KF102120ZX3B	• 71,40	KF102120ZX3	• 68,60
16,00	16,0	15,0	92,0	32,0	44,0	KF102160ZX3B	• 122,60	KF102160ZX3	• 118,60
20,00	20,0	19,0	104,0	38,0	54,0	KF102200ZX3B	• 186,40	KF102200ZX3	• 183,60
25,00	25,0	23,5	121,0	45,0	65,0	KF102250ZX3B	• 297,20	KF102250ZX3	• 291,80

## SOFTMILL TYP ALU

## 4-Schneidig

## KF103

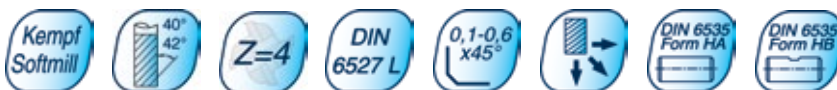

Einsatzgebiete: VHM-Hochleistungsfräser besonders gut geeignet zum Fräsen von Aluminium-Werkstoffen. Mit 40°/42° Spiralwinkel auch optimal für länger spannende Werkstoffe sowie NE-Metalle geeignet.

application: Solid carbide high-performance end mill particularly well suited to machine aluminium materials. Due to the 40°/42° helix also well suited to machine long-chipping materials such as nonferrous metals.

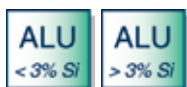

* Kantenschutz ***				
Ø 4 - Ø 5	Ø 6 - Ø 8	Ø 10 - Ø 12	Ø 16	Ø 20
0,1 x 45°	0,150 x 45°	0,200 x 45°	0,350 x 45°	0,450 x 45°

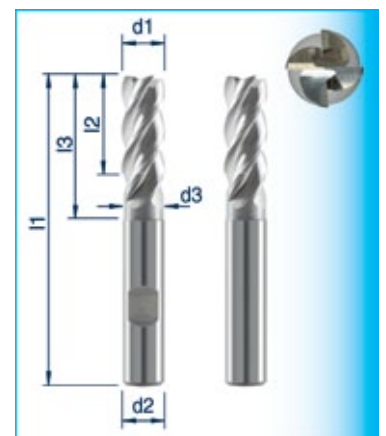

- ab Lager / ex stock
- kurzfristig / on short notice
- Lieferzeit auf Anfrage / delivery time upon request

d1	d2	d3	l1	l2	l3	Artikel-Nr.	Preis	Artikel-Nr.	Preis
h10	h6					(code no.)	Euro / je	(code no.)	Euro / je
mm	mm	mm	mm	mm	mm	Schaft HB	Schaft HB	Schaft HA	Schaft HA
4,00	6,0	3,7	57,0	11,0	18,0	KF103040ALUB	• 18,00	KF103040ALU	• 16,60
5,00	6,0	4,7	57,0	13,0	18,0	KF103050ALUB	• 18,00	KF103050ALU	• 16,60
6,00	6,0	5,5	57,0	13,0	21,0	KF103060ALUB	• 18,00	KF103060ALU	• 16,60
8,00	8,0	7,5	63,0	19,0	27,0	KF103080ALUB	• 20,60	KF103080ALU	• 19,00
10,00	10,0	9,2	72,0	22,0	32,0	KF103100ALUB	• 34,00	KF103100ALU	• 32,00
12,00	12,0	11,2	83,0	26,0	38,0	KF103120ALUB	• 47,40	KF103120ALU	• 44,60
16,00	16,0	15,0	92,0	32,0	44,0	KF103160ALUB	• 78,80	KF103160ALU	• 74,80
20,00	20,0	19,0	104,0	38,0	54,0	KF103200ALUB	• 129,60	KF103200ALU	• 125,40

## SOFTMILL TYP UNI-SCHLICHT

## 6-Schneidig

## KF110 - ZX4



**Einsatzgebiete:** Dieser Schlichtfräser eignet sich bestens für Feinstschlicht-HSC-Operationen und zum Semischruppen mit Zustellbreiten von  $0,3 \times D$ . Durch hohe Drallwinkel werden extrem gute Oberflächenqualitäten erzielt.

**application:** This roughing end mill is optimally suited for fine finishing operations and for semi-roughing operations with feed widths of up to  $0.3 \times \varnothing$ . Due to large helix angles super surface finishes can be obtained.



* Kantenschutz ***		
$\varnothing 8 - \varnothing 10$	$\varnothing 12 - \varnothing 20$	$\varnothing 25$
0,100 x 45°	0,150 x 45°	0,200 x 45°

• ab Lager / ex stock • kurzfristig / on short notice • Lieferzeit auf Anfrage / delivery time upon request

d1 h10 mm	d2 h6 mm	d3 mm	l1 mm	l2 mm	l3 mm	Artikel-Nr. (code no.) Schaft HB	Preis Euro / je Schaft HB	Artikel-Nr. (code no.) Schaft HA	Preis Euro / je Schaft HA
8,00	8,0	7,5	63,0	19,0	27,0	KF110080ZX4B	30,60	KF110080ZX4	28,80
10,00	10,0	9,5	72,0	22,0	32,0	KF110100ZX4B	48,80	KF110100ZX4	46,60
12,00	12,0	11,2	83,0	26,0	38,0	KF110120ZX4B	65,20	KF110120ZX4	62,40
16,00	16,0	15,0	92,0	32,0	44,0	KF110160ZX4B	117,20	KF110160ZX4	111,80
20,00	20,0	19,0	104,0	38,0	54,0	KF110200ZX4B	167,20	KF110200ZX4	160,40
25,00	25,0	23,5	121,0	45,0	65,0	KF110250ZX4B	297,20	KF110250ZX4	291,80

## VHM-SCHAFTFRÄSER 30°

## KF342 und KF343



Einsatzgebiete: Universell einsetzbar, sowohl für hochfeste Werkstoffe als auch für Alu und NE-Metalle geeignet.

application: Universal applications. Suitable for high hard materials as well as aluminium and nonferrous metals.

**KF342 = 2** Schneiden mit Zentrumschnitt / 2 cutting edges, center cutting

**KF343 = 3** Schneiden mit Zentrumschnitt / 3 cutting edges, center cutting

* Durchmessertoleranz (Ø-tolerance) „e8“:				
Ø 2 - Ø 3	Ø 3 - Ø 6	Ø 6 - Ø 10	Ø 10 - Ø 18	Ø 18 - Ø 20
-0,014 / -0,028	-0,020 / -0,038	-0,025 / -0,047	-0,032 / -0,059	-0,040 / -0,073

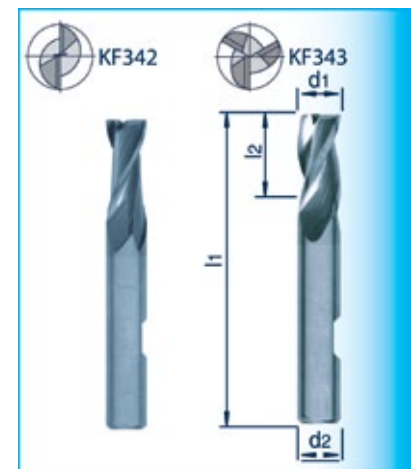

**KF342 = Z2**

**KF343 = Z3**

**universell einsetzbar**

- ab Lager / ex stock
- kurzfristig / on short notice
- Lieferzeit auf Anfrage / delivery time upon request

d1 e8* mm	d2 h6 mm	l2 mm	l1 mm	Artikel-Nr. (code no.)	Preis Euro / je KF342	Artikel-Nr. (code no.)	Preis Euro / je KF343
• 2,0	2,0	8	32	KF342020	7,60	KF343020	7,60
• 2,5	2,5	8	32	KF342025	7,60	KF343025	7,60
• 3,0	3,0	12	32	KF342030	7,60	KF343030	7,60
• 3,5	3,5	12	32	KF342035	7,60	KF343035	7,60
• 4,0	4,0	12	40	KF342040	8,00	KF343040	8,00
• 4,5	4,5	14	50	KF342045	9,80	KF343045	9,80
• 5,0	5,0	14	50	KF342050	9,80	KF343050	9,80
• 5,5	5,5	16	50	KF342055	11,00	KF343055	11,00
• 6,0**	6,0	14	50	KF342060	11,00	KF343060	11,00
• 6,5	6,5	16	50	KF342065	14,80	KF343065	14,80
• 7,0	7,0	20	60	KF342070	14,80	KF343070	14,80
• 7,5	7,5	20	60	KF342075	15,00	KF343075	15,00
• 8,0**	8,0	18	60	KF342080	15,00	KF343080	15,00
• 8,5	8,5	20	60	KF342085	19,60	KF343085	19,60
• 9,0	9,0	20	60	KF342090	19,60	KF343090	19,60
• 9,5	9,5	22	70	KF342095	23,00	KF343095	23,00
• 10,0**	10,0	20	70	KF342100	23,00	KF343100	23,00
• 11,0	11,0	22	70	KF342110	30,80	KF343110	30,80
• 12,0**	12,0	20	70	KF342120	30,80	KF343120	30,80
• 13,0	13,0	25	75	KF342130	44,00	KF343130	44,00
• 14,0**	14,0	22	75	KF342140	41,60	KF343140	41,60
• 15,0	15,0	25	75	KF342150	58,00	KF343150	58,00
• 16,0**	16,0	22	75	KF342160	54,60	KF343160	54,60
• 18,0**	18,0	32	100	KF342180	76,40	KF343180	76,40
• 20,0**	20,0	30	100	KF342200	81,00	KF343200	81,00

\*\* mit Weldon-Spannfläche DIN 6535 Form HB (with weldon flat)

## VHM-SCHAFTFRÄSER 30°

## KF322 / KF323 / KF324 - ZX4



Einsatzgebiete: Universell einsetzbar, sowohl für hochfeste Werkstoffe als auch für Alu und NE-Metalle geeignet.

application: Universal applications. Suitable for high hard materials as well as aluminium and nonferrous metals.

KF322 = 2 Schneiden mit Zentrumschnitt / 2 cutting edges, center cutting

KF323 = 3 Schneiden mit Zentrumschnitt / 3 cutting edges, center cutting

KF324 = 4 Schneiden mit Zentrumschnitt / 4 cutting edges, center cutting

Schutzfase / protection chamfer:

$\varnothing 2 - \varnothing 6$	$\varnothing 8 - \varnothing 10$	$\varnothing 12$	$\varnothing 14 - \varnothing 20$
0,05 - 0,02	0,10 - 0,02	0,15 - 0,02	0,15 $\pm$ 0,02

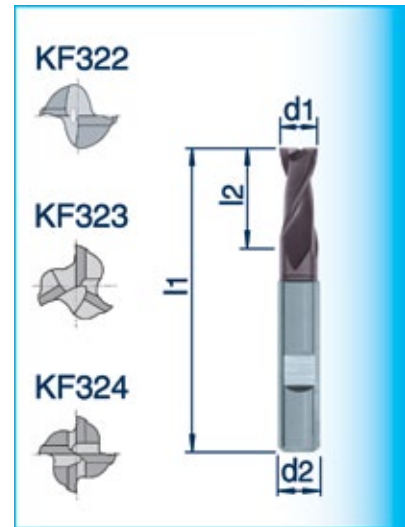

• ab Lager / ex stock • kurzfristig / on short notice • Lieferzeit auf Anfrage / delivery time upon request

### VHM-Schaftfräser KF322 = 2-Schneiden / KF323 = 3-Schneiden

d1 h10 mm	d2 h6 mm	l2 mm	l1 mm	Zähnezahl (no. of cutting edges)	Artikel-Nr. (code no.)	Preis Euro / je KF322 - ZX4	Zähnezahl (no. Of cutting edges)	Artikel-Nr. (code no.)	Preis Euro / je KF323 - ZX4
• 2,0	6	6	57	2	KF322020ZX4	13,60	3	KF323020ZX4	13,60
• 3,0	6	7	57	2	KF322030ZX4	13,60	3	KF323030ZX4	13,60
• 4,0	6	8	57	2	KF322040ZX4	12,80	3	KF323040ZX4	12,80
• 5,0	6	10	57	2	KF322050ZX4	12,80	3	KF323050ZX4	12,80
• 6,0	6	10	57	2	KF322060ZX4	12,00	3	KF323060ZX4	12,00
• 7,0	8	13	63	2	KF322070ZX4	19,80	3	KF323070ZX4	19,80
• 8,0	8	16	63	2	KF322080ZX4	16,40	3	KF323080ZX4	16,40
• 9,0	10	16	72	2	KF322090ZX4	28,40	3	KF323090ZX4	28,40
• 10,0	10	19	72	2	KF322100ZX4	24,00	3	KF323100ZX4	24,00
• 12,0	12	22	83	2	KF322120ZX4	34,00	3	KF323120ZX4	34,00
• 14,0	14	22	83	2	KF322140ZX4	46,60	3	KF323140ZX4	46,60
• 16,0	16	26	92	2	KF322160ZX4	56,40	3	KF323160ZX4	56,40
• 18,0	18	26	92	2	KF322180ZX4	80,80	3	KF323180ZX4	80,80
• 20,0	20	32	104	2	KF322200ZX4	84,60	3	KF323200ZX4	84,60

### VHM-Schaftfräser KF324 = 4-Schneiden

d1 h10 mm	d2 h6 mm	l2 mm	l1 mm	Zähnezahl (no. of cutting edges)	Artikel-Nr. (code no.)	Preis Euro / je KF324 - ZX4
• 2,0	6	7	57	4	KF324020ZX4	13,40
• 3,0	6	8	57	4	KF324030ZX4	14,20
• 4,0	6	11	57	4	KF324040ZX4	14,20
• 5,0	6	13	57	4	KF324050ZX4	14,80
• 6,0	6	13	57	4	KF324060ZX4	14,80
• 7,0	8	16	63	4	KF324070ZX4	17,40
• 8,0	8	19	63	4	KF324080ZX4	17,40
• 9,0	10	19	72	4	KF324090ZX4	22,40
• 10,0	10	22	72	4	KF324100ZX4	27,40
• 12,0	12	26	83	4	KF324120ZX4	37,20
• 14,0	14	26	83	4	KF324140ZX4	47,20
• 16,0	16	32	92	4	KF324160ZX4	62,60
• 18,0	18	32	92	4	KF324180ZX4	80,00
• 20,0	20	38	104	4	KF324200ZX4	99,00

## VHM-SCHAFTFRÄSER 30° EXTRA LANG KF392 / KF393 / KF394 - ZX4



Einsatzgebiete: Universell einsetzbar, sowohl für hochfeste Werkstoffe als auch für Alu und NE-Metalle geeignet.

application: Universal applications. Suitable for high hard materials as well as aluminium and nonferrous metals.

KF392 EXTRA LANG = 2 Schneiden mit Zentrumschnitt / 2 cutting edges, center cutting, EXTRA LONG  
 KF393 EXTRA LANG = 3 Schneiden mit Zentrumschnitt / 3 cutting edges, center cutting, EXTRA LONG  
 KF394 EXTRA LANG = 4 Schneiden mit Zentrumschnitt / 4 cutting edges, center cutting, EXTRA LONG

Schutzfase / protection chamfer:			
Ø 2 - Ø 6	Ø 8 - Ø 10	Ø 12	Ø 14 - Ø 20
0,05 - 0,02	0,10 - 0,02	0,15 - 0,02	0,15 ± 0,02

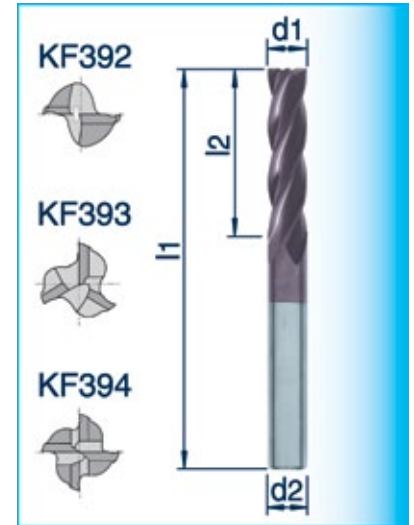

• ab Lager / ex stock • kurzfristig / on short notice • Lieferzeit auf Anfrage / delivery time upon request

### VHM-Schaftfräser KF392 Extra Lang - 2-Schneiden - ZX4

d1	d2	l2	l1	Zähnezahl	Artikel-Nr. (code no.)	Preis	Artikel-Nr. (code no.)	Preis
h10	h6			(no. of	ohne Spannfläche	Euro / je	mit Spannfläche	Euro / je
mm	mm	mm	mm	cutting edges)	without Weldon flat	KF392 - ZX4	with Weldon flat	KF392 - ZX4
• 3,0	3	20	75	2	KF392030ZX4	14,20	---	---
• 4,0	4	25	75	2	KF392040ZX4	16,20	---	---
• 5,0	5	30	75	2	KF392050ZX4	17,40	---	---
• 6,0	6	30	75	2	KF392060ZX4	21,80	KF392060WZX4	24,00
• 8,0	8	40	100	2	KF392080ZX4	27,40	KF392080WZX4	29,80
• 10,0	10	40	100	2	KF392100ZX4	33,20	KF392100WZX4	35,60
• 12,0	12	45	150	2	KF392120ZX4	51,20	KF392120WZX4	55,80
• 14,0	14	45	150	2	KF392140ZX4	62,60	KF392140WZX4	67,20
• 16,0	16	65	150	2	KF392160ZX4	83,20	KF392160WZX4	87,80
• 18,0	18	65	150	2	KF392180ZX4	99,00	KF392180WZX4	103,60
• 20,0	20	65	150	2	KF392200ZX4	112,80	KF392200WZX4	117,40

### VHM-Schaftfräser KF393 Extra Lang - 3-Schneiden - ZX4

d1	d2	l2	l1	Zähnezahl	Artikel-Nr. (code no.)	Preis	Artikel-Nr. (code no.)	Preis
h10	h6			(no. of	ohne Spannfläche	Euro / je	mit Spannfläche	Euro / je
mm	mm	mm	mm	cutting edges)	without Weldon flat	KF393 - ZX4	with Weldon flat	KF393 - ZX4
• 3,0	3	20	75	3	KF393030ZX4	18,20	---	---
• 4,0	4	25	75	3	KF393040ZX4	20,40	---	---
• 5,0	5	30	75	3	KF393050ZX4	22,40	---	---
• 6,0	6	30	75	3	KF393060ZX4	28,60	---	auf Anfrage
• 8,0	8	40	100	3	KF393080ZX4	32,00	---	auf Anfrage
• 10,0	10	40	100	3	KF393100ZX4	42,00	---	auf Anfrage
• 12,0	12	45	150	3	KF393120ZX4	59,60	---	auf Anfrage
• 16,0	16	65	150	3	KF393160ZX4	104,60	---	auf Anfrage
• 20,0	20	65	150	3	KF393200ZX4	139,00	---	auf Anfrage

### VHM-Schaftfräser KF394 Extra Lang - 4-Schneiden - ZX4

d1	d2	l2	l1	Zähnezahl	Artikel-Nr. (code no.)	Preis	Artikel-Nr. (code no.)	Preis
h10	h6			(no. of	ohne Spannfläche	Euro / je	mit Spannfläche	Euro / je
mm	mm	mm	mm	cutting edges)	without Weldon flat	KF394 - ZX4	with Weldon flat	KF394 - ZX4
• 3,0	3	20	75	4	KF394030ZX4	14,20	---	---
• 4,0	4	25	75	4	KF394040ZX4	16,20	---	---
• 5,0	5	30	75	4	KF394050ZX4	17,40	---	---
• 6,0	6	30	75	4	KF394060ZX4	21,80	KF394060WZX4	24,00
• 8,0	8	40	100	4	KF394080ZX4	27,40	KF394080WZX4	29,80
• 10,0	10	40	100	4	KF394100ZX4	33,20	KF394100WZX4	35,60
• 12,0	12	45	150	4	KF394120ZX4	51,20	KF394120WZX4	55,80
• 14,0	14	45	150	4	KF394140ZX4	62,60	KF394140WZX4	67,20
• 16,0	16	65	150	4	KF394160ZX4	83,20	KF394160WZX4	87,80
• 18,0	18	65	150	4	KF394180ZX4	99,00	KF394180WZX4	103,60
• 20,0	20	65	150	4	KF394200ZX4	112,80	KF394200WZX4	117,40

## VHM-MINI SCHAFTFRÄSER 45°

## KF300 - ZX3



Einsatzgebiete: Universell einsetzbar, sowohl für hochfeste Werkstoffe als auch für Alu und NE-Metalle geeignet.

application: Universal applications. Suitable for high hard materials as well as aluminium and nonferrous metals.

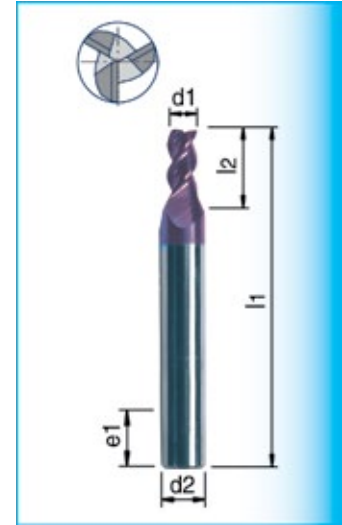

\* Durchmesser tolerance (Ø-tolerance) „e8“:

Ø 2 - Ø 3	Ø 3 - Ø 6	Ø 6 - Ø 10		
-0,014 / -0,028	-0,020 / -0,038	-0,025 / 0,047		



- ab Lager / ex stock
- kurzfristig / on short notice
- Lieferzeit auf Anfrage / delivery time upon request

	d1	d2	l2	l1	Länge e1	Artikel-Nr. (code no.)	Preis Euro / je KF300 - ZX3
	e8*	h6	h6	h6			
	mm	mm	mm	mm			
•	0,5	3,0	1,5	45	-	KF300005ZX3	13,20
•	1,0	3,0	2,0	45	-	KF300010ZX3	13,20
•	1,5	3,0	3,0	45	-	KF300015ZX3	13,20
•	1,8	3,0	3,0	45	-	KF300018ZX3	13,20
•	2,0	6,0	4,0	45	8,0	KF300020ZX3	13,20
•	2,8	6,0	6,0	45	8,0	KF300028ZX3	14,60
•	3,0	6,0	6,0	45	8,0	KF300030ZX3	13,20
•	3,8	6,0	7,0	45	8,0	KF300038ZX3	14,60
•	4,0	6,0	7,0	45	8,0	KF300040ZX3	13,20
•	4,8	6,0	8,0	45	8,0	KF300048ZX3	14,60
•	5,0	6,0	8,0	45	8,0	KF300050ZX3	13,20
•	5,75	6,0	10,0	45	8,0	KF300057ZX3	14,60
•	6,0	6,0	10,0	45	8,0	KF300060ZX3	13,20
•	6,75	8,0	10,0	55	11,0	KF300067ZX3	20,40
•	7,0	8,0	12,0	55	11,0	KF300070ZX3	18,80
•	7,75	8,0	12,0	55	11,0	KF300077ZX3	20,40
•	8,0	8,0	13,0	55	11,0	KF300080ZX3	18,80
•	8,7	10,0	14,0	55	7,0	KF300087ZX3	24,80
•	9,7	10,0	16,0	55	7,0	KF300097ZX3	24,80
•	10,0	10,0	16,0	55	7,0	KF300100ZX3	22,60

## VHM-SCHLICHTFRÄSER 45°

## KF308 / KF309 - ZX3



Einsatzgebiete: Speziell geeignet zum Umfangsfräsen zur Erzeugung höchster Oberflächengüten. Universell einsetzbar, sowohl für hochfeste Werkstoffe als auch für Alu und NE-Metalle geeignet.

application: Well suited for machining of circumference to achieve high surface qualities. Universal use, suited for high-tensile materials as well as for Al and nonferrous materials.

* Durchmesser toleranz (Ø-tolerance) „f8“:			
Ø 3 - Ø 6	Ø 6 - Ø 10	Ø 10 - Ø 18	Ø 18 - Ø 20
-0,010 / -0,028	-0,013 / -0,035	-0,016 / -0,043	-0,020 / -0,053

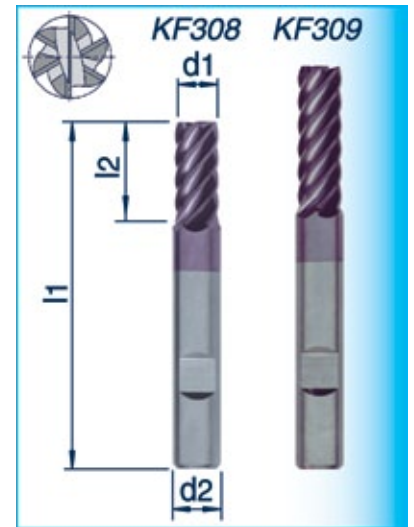

- ab Lager / ex stock
- kurzfristig / on short notice
- Lieferzeit auf Anfrage / delivery time upon request

### VHM-Schlichtfräser KF308 DIN 6527 Lang - ZX3

\*solange Vorrat reicht\*

d1 f8* mm	d2 h6 mm	l2 mm	l1 mm	Zähnezahl (no. of cutting edges)	Artikel-Nr. (code no.)	Preis Euro / je KF308 - ZX3	
**	4,0	6,0	11,0	57,0	6	KF308040ZX3	13,80
**	5,0	6,0	13,0	57,0	6	KF308050ZX3	13,80
**	6,0	6,0	13,0	57,0	6	KF308060ZX3	13,80
**	7,0	8,0	16,0	63,0	6	KF308070ZX3	16,20
**	8,0	8,0	19,0	63,0	6	KF308080ZX3	16,20
**	9,0	10,0	19,0	72,0	6	KF308090ZX3	32,40
**	10,0	10,0	22,0	72,0	6	KF308100ZX3	27,80
**	12,0	12,0	26,0	83,0	6	KF308120ZX3	32,80
**	14,0	14,0	26,0	83,0	6	KF308140ZX3	56,80
**	16,0	16,0	32,0	92,0	6	KF308160ZX3	57,20
**	18,0	18,0	32,0	92,0	8	KF308180ZX3	87,20
**	20,0	20,0	38,0	104,0	8	KF308200ZX3	80,80

### VHM-Schlichtfräser KF309 EXTRA LANG - ZX3

\*solange Vorrat reicht\*

d1 f8* mm	d2 h6 mm	l2 mm	l1 mm	Zähnezahl (no. of cutting edges)	Artikel-Nr. (code no.)	Preis Euro / je KF309 - ZX3	
**	4,0	6,0	16,0	62,0	6	KF309040ZX3	16,40
**	5,0	6,0	18,0	62,0	6	KF309050ZX3	16,40
**	6,0	6,0	18,0	62,0	6	KF309060ZX3	16,40
**	7,0	8,0	21,0	68,0	6	KF309070ZX3	31,40
**	8,0	8,0	24,0	68,0	6	KF309080ZX3	18,80
**	9,0	10,0	27,0	80,0	6	KF309090ZX3	49,40
**	10,0	10,0	30,0	80,0	6	KF309100ZX3	33,00
**	12,0	12,0	36,0	93,0	6	KF309120ZX3	38,80
**	14,0	14,0	42,0	99,0	6	KF309140ZX3	88,80
**	16,0	16,0	48,0	108,0	6	KF309160ZX3	72,40
**	18,0	18,0	54,0	114,0	8	KF309180ZX3	139,80
**	20,0	20,0	60,0	126,0	8	KF309200ZX3	100,20
**	25,0	25,0	95,0	160,0	8	KF309250ZX3	299,80

Weitere lieferbare Ausführungen:

- VHM-Schlichtfräser mit Eckenradius
- VHM-Schlichtfräser mit abgesetztem Schaft (Halseinschliff)
- andere Durchmesser und Längen auf Anfrage

## VHM-ALU-FRÄSER 45° kurz / lang / extra lang

## KF302 / KF396



Einsatzgebiete: Speziell geeignet zum Fräsen von Aluminiumlegierungen, Kunststoffen, Kupferlegierungen und NE-Metallen.

application: Especially suited for milling of aluminium alloys, plastics, copper alloys and non-ferrous metals.

* Durchmesser-toleranz (Ø-tolerance) „e8“:					Schutzfase / protection chamfer			
Ø2-Ø3	Ø3-Ø6	Ø6-Ø10	Ø10-Ø18	Ø18-Ø20	Ø2-Ø6	Ø8-Ø10	Ø12	Ø14-Ø20
-0,014 / -0,028	-0,020 / -0,038	-0,025 / -0,047	-0,032 / -0,059	-0,040 / -0,073	0,03-0,02	0,05-0,02	0,10-0,02	0,10±0,02



• ab Lager / ex stock • kurzfristig / on short notice • Lieferzeit auf Anfrage / delivery time upon request

### VHM-ALU-FRÄSER Typ KF302 kurz/lang - Schaft DIN 6535 Form HB

d1 e8* mm	d2 h6 mm	l2 mm	l1 mm	Zähnezahl (no. of cutting edges)	Artikel-Nr. (code no.)	Preis Euro / je KF302 ALU
• 3,0	6,0	4,0	50,0	2	KF302030ALUK	8,80
• 3,0	6,0	7,0	57,0	2	KF302030ALUL	10,60
• 4,0	6,0	5,0	54,0	2	KF302040ALUK	8,80
• 4,0	6,0	8,0	57,0	2	KF302040ALUL	10,60
• 5,0	6,0	6,0	54,0	2	KF302050ALUK	8,80
• 5,0	6,0	10,0	57,0	2	KF302050ALUL	10,60
• 6,0	6,0	7,0	54,0	2	KF302060ALUK	8,80
• 6,0	6,0	10,0	57,0	2	KF302060ALUL	10,60
• 8,0	8,0	9,0	58,0	2	KF302080ALUK	10,20
• 8,0	8,0	16,0	63,0	2	KF302080ALUL	12,00
• 10,0	10,0	11,0	66,0	2	KF302100ALUK	13,60
• 10,0	10,0	19,0	72,0	2	KF302100ALUL	20,80
• 12,0	12,0	12,0	73,0	2	KF302120ALUK	20,80
• 12,0	12,0	22,0	83,0	2	KF302120ALUL	30,00
• 14,0	14,0	14,0	75,0	2	KF302140ALUK	27,40
• 14,0	14,0	22,0	83,0	2	KF302140ALUL	36,00
• 16,0	16,0	16,0	82,0	2	KF302160ALUK	31,60
• 16,0	16,0	26,0	92,0	2	KF302160ALUL	49,60
• 18,0	18,0	18,0	84,0	2	KF302180ALUK	41,40
• 18,0	18,0	26,0	92,0	2	KF302180ALUL	56,00
• 20,0	20,0	20,0	92,0	2	KF302200ALUK	54,80
• 20,0	20,0	32,0	104,0	2	KF302200ALUL	76,60

### VHM-ALU-FRÄSER Typ KF396 EXTRA LANG - Schaft DIN 6535 Form HA

d1 h10 mm	d2 h6 mm	l2 mm	l1 mm	Zähnezahl (no. of cutting edges)	Artikel-Nr. (code no.)	Preis Euro / je KF396 ALU
• 5,0	5,0	30	75	2	KF396050ALU	17,20
• 6,0	6,0	30	75	2	KF396060ALU	23,40
• 8,0	8,0	40	100	2	KF396080ALU	28,20
• 10,0	10,0	40	100	2	KF396100ALU	39,60
• 12,0	12,0	45	150	2	KF396120ALU	62,20
• 16,0	16,0	65	150	2	KF396160ALU	114,40

## VHM-ALU-SCHRUPPFRÄSER

## KF312 / KF313-(mit IK)



Einsatzgebiete: Speziell geeignet zum Fräsen von Aluminiumlegierungen, Kupferlegierungen, Kunststoffen und NE-Metallen.

application: Especially suited for milling of aluminium alloys, plastics, copper alloys and non-ferrous metals.

**KF312** = ALU-Schruppfräser ohne Innenkühlung / end mill for AL without inner coolant supply

**KF313** = ALU-Schruppfräser mit Innenkühlung / end mill for AL with inner coolant supply



• ab Lager / ex stock • kurzfristig / on short notice • Lieferzeit auf Anfrage / delivery time upon request

d1 h10 mm	d2 h6 mm	l2 mm	l1 mm	Artikel-Nr. (code no.) ohne Innenkühlung without inner coolant	Preis Euro / je ohne Innenkühlung without inner coolant	Artikel-Nr. (code no.) mit Innenkühlung with inner coolant	Preis Euro / je mit Innenkühlung with inner coolant
• 6,0	6,0	10	57	KF312060ALU	22,20	KF313060ALU	31,00
• 8,0	8,0	16	63	KF312080ALU	23,00	KF313080ALU	35,00
• 10,0	10,0	19	72	KF312100ALU	28,20	KF313100ALU	38,20
• 12,0	12,0	22	83	KF312120ALU	34,60	KF313120ALU	53,60
• 16,0	16,0	26	92	KF312160ALU	52,60	KF313160ALU	78,00
• 20,0	20,0	32	104	KF312200ALU	99,00	KF313200ALU	134,20

## VHM-ALU-FRÄSER mit Innenkühlung

## KF318



Einsatzgebiete: Speziell zum Fräsen von Aluminiumlegierungen, Kunststoffen, Kupferlegierungen und NE-Metallen.

application: Especially suited for milling of aluminium alloys, plastics, copper alloys and non-ferrous metals.

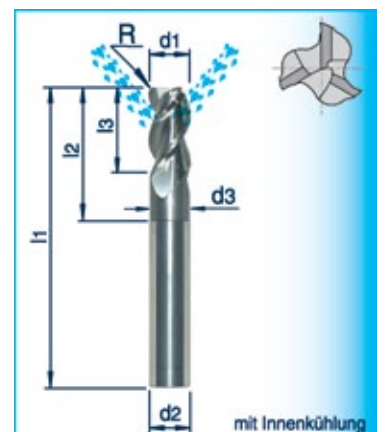

• ab Lager / ex stock • kurzfristig / on short notice • Lieferzeit auf Anfrage / delivery time upon request

d1 h10 mm	Radius R mm	d2 h6 mm	d3 mm	l1 mm	l2 mm	l3 mm	Zähnezahl (no. of cutting edges)	Artikel-Nr. (code no.)	Preis Euro / je KF318
• 6,0	1,0	6,0	5,7	57,0	21,0	10,0	3	KF318060ALU	17,80
• 8,0	1,0	8,0	7,7	63,0	27,0	16,0	3	KF318080ALU	19,80
• 10,0	1,5	10,0	9,5	72,0	32,0	19,0	3	KF318100ALU	35,20
• 12,0	1,5	12,0	11,5	83,0	38,0	22,0	3	KF318120ALU	52,60
• 16,0	2,0	16,0	15,5	92,0	44,0	26,0	3	KF318160ALU	84,20
• 20,0	2,5	20,0	19,5	104,0	54,0	32,0	3	KF318200ALU	120,20

## VHM-HSC-EINZAHNFRÄSER

## KF535



Einsatzgebiete: Einzahnfräser mit geläppter Spannutt und extrem scharfer Schneide zur Bearbeitung von Aluminium und Kunststoff. Geläppte Spannutt mit niedrigem Reibungskoeffizient und extrem begünstigtem Spanabfluss.

application: Single cutting edge end mill with lapped chip flute and extremely sharp cutting edge to machine aluminium and plastics. Lapped chip flute with low friction coefficient supports chip removal.



Hinweis: Einzahnfräser sind auch mit Linksdrahl (rechtsschneidend) ohne Aufpreis kurzfristig lieferbar.  
Note: These end mills are also available with lefthand-twist (RH-cutting) on short notice at no surcharge.

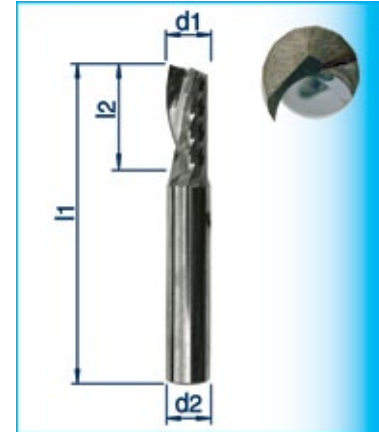

• ab Lager / ex stock • kurzfristig / on short notice • Lieferzeit ca. 1-2 Wochen / delivery time approx. 1-2 weeks

### VHM-HSC-Einzahnfräser mit geläppter Spannutt

	d1 h10 mm	d2 h6 mm	l1 mm	l2 mm	Zähnezahl (no. of cutting edges)	Artikel-Nr. (code no.)	Preis Euro / je KF535
•	2,0	2,0	40,0	10,0	1	KF535020	9,00
•	3,0	3,0	40,0	12,0	1	KF535030	9,60
•	4,0	4,0	40,0	15,0	1	KF535040	11,60
•	5,0	5,0	50,0	16,0	1	KF535050	15,00
•	6,0	6,0	60,0	20,0	1	KF535060	17,20
•	8,0	8,0	63,0	22,0	1	KF535080	27,60
•	10,0	10,0	72,0	25,0	1	KF535100	41,60
•	12,0	12,0	83,0	30,0	1	KF535120	55,00
•	14,0	14,0	83,0	30,0	1	KF535140	82,40
•	16,0	16,0	92,0	35,0	1	KF535160	116,80
•	18,0	18,0	92,0	35,0	1	KF535180	139,80
•	20,0	20,0	104,0	40,0	1	KF535200	157,00

### VHM-HSC-Einzahnfräser mit geläppter Spannutt und verstärktem Schaft

	d1 h10 mm	d2 h6 mm	l1 mm	l2 mm	Zähnezahl (no. of cutting edges)	Artikel-Nr. (code no.)	Preis Euro / je KF535
•	1,0	6,0	50,0	4,0	1	KF535010V	20,60
•	2,0	6,0	50,0	6,0	1	KF535020V1	20,60
•	2,0	6,0	50,0	20,0	1	KF535020V2	21,60
•	3,0	6,0	50,0	11,0	1	KF535030V1	20,60
•	3,0	6,0	50,0	22,0	1	KF535030V2	21,60
•	4,0	6,0	50,0	14,0	1	KF535040V1	20,60
•	4,0	6,0	50,0	22,0	1	KF535040V2	21,60
•	5,0	6,0	50,0	22,0	1	KF535050V	21,60
•	6,0	6,0	50,0	22,0	1	KF535060V	21,60

### VHM-HSC-Micro-Einzahnfräser mit geläppter Spannutt und verstärktem Schaft

	d1 h10 mm	d2 h6 mm	l1 mm	l2 mm	Zähnezahl (no. of cutting edges)	Artikel-Nr. (code no.)	Preis Euro / je KF535
•	0,5	3,0	39,0	1,5	1	KF535005M	13,80
•	0,6	3,0	39,0	1,5	1	KF535006M	13,80
•	0,8	3,0	39,0	2,0	1	KF535008M	15,00
•	1,0	3,0	39,0	3,0	1	KF535010M	13,80
•	1,2	3,0	39,0	4,0	1	KF535012M	13,80
•	1,4	3,0	39,0	4,0	1	KF535014M	15,00
•	1,5	3,0	39,0	4,0	1	KF535015M	15,00
•	1,6	3,0	39,0	4,0	1	KF535016M	15,60
•	1,8	3,0	39,0	5,0	1	KF535018M	15,60
•	2,0	3,0	39,0	5,0	1	KF535020M	15,00
•	2,5	3,0	39,0	7,0	1	KF535025M	16,60
•	3,0	3,0	39,0	10,0	1	KF535030M	19,60

## VHM-HSC-SCHAFTFRÄSER mit geläppter Spannutt

KF536



Einsatzgebiete: Schaftfräser mit geläppter Spannutt und extrem scharfer Schneide zur Bearbeitung von Aluminium und Kunststoff. Geläppte Spannutt mit niedrigem Reibungskoeffizient und extrem begünstigtem Spanabfluss.

application: Single cutting edge end mill with lapped chip flute and extremely sharp cutting edge to machine aluminium and plastics. Lapped chip flute with low friction coefficient supports chip removal.

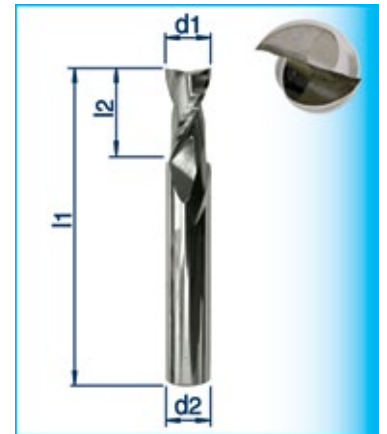

- ab Lager / ex stock
- kurzfristig / on short notice
- Lieferzeit ca. 1-2 Wochen / delivery time approx. 1-2 weeks

	d1 h10 mm	d2 h6 mm	l1 mm	l2 mm	Zähnezahl (no. of cutting edges)	Artikel-Nr. (code no.)	Preis Euro / je KF536
•	3,0	3,0	40,0	12,0	2	KF536030	12,00
•	4,0	4,0	40,0	14,0	2	KF536040	13,00
•	5,0	5,0	50,0	16,0	2	KF536050	15,00
•	6,0	6,0	50,0	18,0	2	KF536060	19,20
•	8,0	8,0	63,0	20,0	2	KF536080	28,60
•	10,0	10,0	72,0	25,0	2	KF536100	38,20
•	12,0	12,0	83,0	30,0	2	KF536120	52,40
•	16,0	16,0	92,0	35,0	2	KF536160	111,20
•	20,0	20,0	104,0	45,0	2	KF536200	157,00

## VHM-HSC-SCHAFTFRÄSER mit geläppter Spannutt

KF537



Einsatzgebiete: Schaftfräser mit geläppter Spannutt und extrem scharfer Schneide zur Bearbeitung von Aluminium und Kunststoff. Geläppte Spannutt mit niedrigem Reibungskoeffizient und extrem begünstigtem Spanabfluss.

application: Single cutting edge end mill with lapped chip flute and extremely sharp cutting edge to machine aluminium and plastics. Lapped chip flute with low friction coefficient supports chip removal.

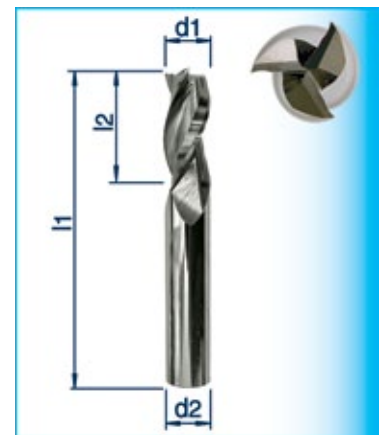

- ab Lager / ex stock
- kurzfristig / on short notice
- Lieferzeit ca. 1-2 Wochen / delivery time approx. 1-2 weeks

	d1 h10 mm	d2 h6 mm	l1 mm	l2 mm	Zähnezahl (no. of cutting edges)	Artikel-Nr. (code no.)	Preis Euro / je KF537
•	3,0	3,0	40,0	12,0	3	KF537030	13,20
•	4,0	4,0	40,0	14,0	3	KF537040	14,40
•	5,0	5,0	50,0	16,0	3	KF537050	16,40
•	6,0	6,0	50,0	18,0	3	KF537060	20,80
•	8,0	8,0	63,0	20,0	3	KF537080	30,00
•	10,0	10,0	72,0	25,0	3	KF537100	40,20
•	12,0	12,0	83,0	30,0	3	KF537120	55,00
•	16,0	16,0	92,0	35,0	3	KF537160	116,80
•	20,0	20,0	104,0	45,0	3	KF537200	165,00

## VHM-HSC-SCHAFTFRÄSER Diamantverzahnt/Stirnverzahnt KF630



Einsatzgebiete: Schaftfräser mit Diamantverzahnung und mehrschneidiger Stirnverzahnung zur Bearbeitung von Faserkunststoffen und Schaumwerkstoffen.

application: End mill with diamond-cut and multiple end cut. To machine fiber plastics and foam materials.



Diamant-beschichtete Vollhartmetallfräser sind auch in anderen Längen und Durchmessern erhältlich.  
Diamond-coated solid carbide end mills are available with other lengths and diameters upon request.



• ab Lager / ex stock • kurzfristig / on short notice • Lieferzeit auf Anfrage / delivery time upon request

	d1 h10 mm	d2 h6 mm	l1 mm	l2 mm	Artikel-Nr. (code no.)	Preis Euro / je KF630
•	3,0	3,0	40	10	KF630030	10,60
•	4,0	4,0	40	15	KF630040	13,00
•	5,0	5,0	50	16	KF630050	17,20
•	6,0	6,0	50	18	KF630060	19,00
•	8,0	8,0	63	25	KF630080	28,40
•	10,0	10,0	72	30	KF630100	39,40
•	12,0	12,0	82	32	KF630120	55,60

Hinweis: Diese Fräser erhalten Sie auch mit einer Diamantbeschichtung (für Graphitbearbeitung).

Note: Also available with diamond coating on short notice (to machine graphite).

## VHM-HSC-SCHAFTFRÄSER Diamantverzahnt/Stirnschnitt für Nuten KF631



Einsatzgebiete: Nutfräser mit Diamantverzahnung und zweischneidiger Stirnverzahnung zur Bearbeitung von Faserkunststoffen und Schaumwerkstoffen.

application: Groove mill with diamond cut and double front-cut to machine fiber plastics and foam materials.



Diamant-beschichtete Vollhartmetallfräser sind auch in anderen Längen und Durchmessern erhältlich.  
Diamond-coated solid carbide end mills are available with other lengths and diameters upon request.

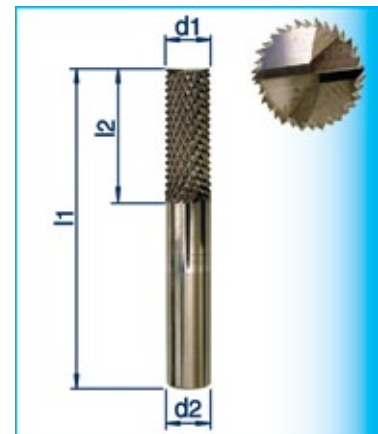

• ab Lager / ex stock • kurzfristig / on short notice • Lieferzeit auf Anfrage / delivery time upon request

	d1 h10 mm	d2 h6 mm	l1 mm	l2 mm	Artikel-Nr. (code no.)	Preis Euro / je KF631
•	2,0	2,0	40	7,0	KF631020	11,60
•	3,0	3,0	40	10,0	KF631030	11,60
•	4,0	4,0	40	15,0	KF631040	14,00
•	5,0	5,0	50	16,0	KF631050	18,60
•	6,0	6,0	50	18,0	KF631060	20,40
•	8,0	8,0	63	25,0	KF631080	30,60
•	10,0	10,0	72	30,0	KF631100	41,80
•	12,0	12,0	82,0	32,0	KF631120	58,60

## VHM-HSC-SCHAFTFRÄSER Diamantverzahnt/Bohrerspitze 135° KF632



Einsatzgebiete: Schaftfräser mit Diamantverzahnung und Bohrspitze zur Bearbeitung von Faserkunststoffen und Schaumwerkstoffen.

application: End mill with diamond-cut and drill tip to machine fiber plastics and foam materials.



Diamant-beschichtete Vollhartmetallfräser sind auch in anderen Längen und Durchmessern erhältlich.  
Diamond-coated solid carbide end mills are available with other lengths and diameters upon request.

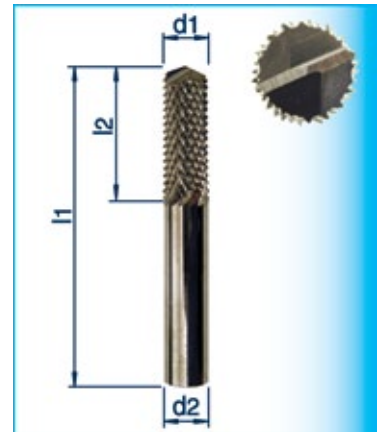

• ab Lager / ex stock • kurzfristig / on short notice • Lieferzeit auf Anfrage / delivery time upon request

	d1 h10 mm	d2 h6 mm	l1 mm	l2 mm	Artikel-Nr. (code no.)	Preis Euro / je KF632
•	3,0	3,0	40	10,0	KF632030	12,40
•	3,5	3,5	40	12,0	KF632035	13,60
•	4,0	4,0	40	15,0	KF632040	14,40
•	5,0	5,0	50	16,0	KF632050	19,60
•	6,0	6,0	50	18,0	KF632060	21,00
•	8,0	8,0	63	25,0	KF632080	31,00
•	10,0	10,0	72	30,0	KF632100	42,40
•	12,0	12,0	82	32,0	KF632120	59,80

Hinweis: Diese Fräser erhalten Sie auch mit einer Diamantbeschichtung (für Graphitbearbeitung).  
Note: Also available with diamond coating on short notice (to machine graphite).

### Info zu Fräserarten mit Pyramidenverzahnung / Diamantverzahnung

Diese Fräser werden in einem speziellen Schleifverfahren hergestellt. Es führt zu höchster Fertigungsqualität und kombiniert zwei wichtige Charakteristiken:  
- polierte Spannuten und scharfe Schneidkanten

Hierdurch werden beim Werkzeug folgende Eigenschaften erreicht:

- geringer Reibungskoeffizient
- bessere Spanabfuhr
- hohe Schnitthaltigkeit
- hohe Werkzeuglebensdauer



### Info zu Fräserarten mit Pyramidenverzahnung / Diamantverzahnung

Typ KF630 - mit mehrschneidiger Stirnverzahnung  
Stirnfräsen / Umfangsfräsen / Besäumen



Typ KF631 - mit zweischneidiger Stirnverzahnung  
Tauchen / Nutfräsen / Umfangsfräsen



Typ KF632 - mit Bohrspitze 135°  
Bohren / Zuschneiden / Besäumen



## PKD-SCHAFTFRÄSER mit Innenkühlung Achswinkel neutral KF910



Einsatzgebiete: Für die Bearbeitung von NE-Metallen wie Aluminium, Messing, Bronze, Kupfer, GFK, CFK, Graphit und Kohlenstoffe, Duroplaste und Thermoplaste.

application: For machining of non-ferrous metals such as aluminium, brass, bronze, copper, GRP and CFK, graphite and carbons, curable and thermo plastics.



• ab Lager / ex stock • kurzfristig / on short notice • Lieferzeit auf Anfrage / delivery time upon request

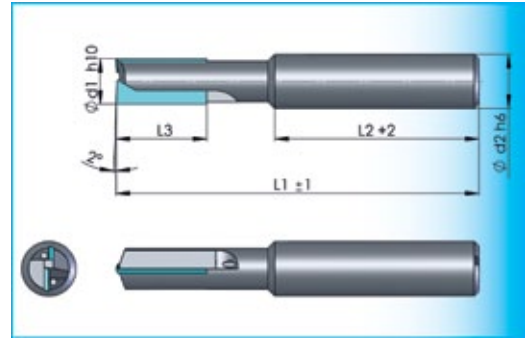

Hinweis: Auch mit 3D-Spanleitstufe lieferbar!

	d1 h10 mm	d2 h6 mm	l1 Gesamtlänge mm	l2 Schaftlänge mm	l3 (PKD-Länge) mm	Artikel-Nr. (code no.)	Preis Euro / je KF910
•	6	8	60	36	10	KF9100601	137,00
•	6	8	80	36	20	KF9100602	196,00
•	8	10	60	40	10	KF9100801	140,80
•	8	10	80	40	20	KF9100802	222,20
•	10	12	70	45	10	KF9101001	152,00
•	10	12	90	45	20	KF9101002	228,80
•	12	14	70	45	10	KF9101201	171,80
•	12	14	90	45	20	KF9101202	253,00
•	14	16	80	48	10	KF9101401	202,60
•	14	16	100	48	20	KF9101402	290,60
•	16	16	90	48	10	KF9101601	226,60
•	16	16	110	48	20	KF9101602	317,00
•	18	20	100	50	10	KF9101801	255,20
•	18	20	120	50	20	KF9101802	356,60
•	20	20	140	50	10	KF9102001	284,00
•	20	20	150	50	20	KF9102002	391,80

## PKD-SCHAFTFRÄSER mit Innenkühlung Achswinkel positiv KF915



Einsatzgebiete: Für die Bearbeitung von NE-Metallen wie Aluminium, Messing, Bronze, Kupfer, GFK, CFK, Graphit und Kohlenstoffe, Duroplaste und Thermoplaste.

application: For machining of non-ferrous metals such as aluminium, brass, bronze, copper, GRP and CFK, graphite and carbons, curable and thermo plastics.



• Lieferzeit ca. 4-5 Wochen (approx. 4-5 weeks delivery)  
Mindestabnahme 3 Stk (minimum order quantity 3 pcs)

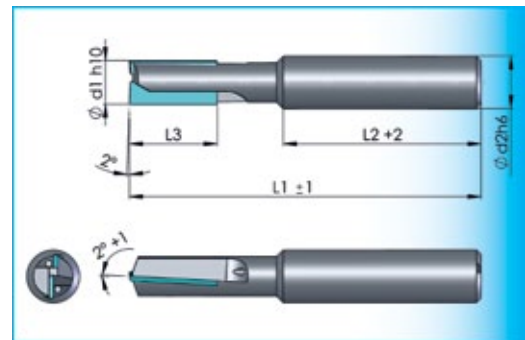

Hinweis: Auch mit 3D-Spanleitstufe lieferbar!

	d1 h10 mm	d2 h6 mm	l1 Gesamtlänge mm	l2 Schaftlänge mm	l3 (PKD-Länge) mm	Artikel-Nr. (code no.)	Preis Euro / je KF915
•	6	8	60	36	10	KF9150601	137,00
•	6	8	80	36	20	KF9150602	196,00
•	8	10	60	40	10	KF9150801	140,80
•	8	10	80	40	20	KF9150802	222,20
•	10	12	70	45	10	KF9151001	152,00
•	10	12	90	45	20	KF9151002	228,80
•	12	14	70	45	10	KF9151201	171,80
•	12	14	90	45	20	KF9151202	253,00
•	14	16	80	48	10	KF9151401	202,60
•	14	16	100	48	20	KF9151402	290,60
•	16	16	90	48	10	KF9151601	226,60
•	16	16	110	48	20	KF9151602	317,00
•	18	20	100	50	10	KF9151801	255,20
•	18	20	120	50	20	KF9151802	356,60
•	20	20	140	50	10	KF9152001	284,00
•	20	20	150	50	20	KF9152002	391,80

## PKD-SCHAFTFRÄSER mit Innenkühlung Achswinkel negativ KF920



Einsatzgebiete: Für die Bearbeitung von NE-Metallen wie Aluminium, Messing, Bronze, Kupfer, GFK, CFK, Graphit und Kohlenstoffe, Duroplaste und Thermoplaste.

application: For machining of non-ferrous metals such as aluminium, brass, bronze, copper, GRP and CFK, graphite and carbons, curable and thermo plastics.



• Lieferzeit ca. 4-5 Wochen (approx. 4-5 weeks delivery)  
Mindestabnahme 3 Stk (minimum order quantity 3 pcs)

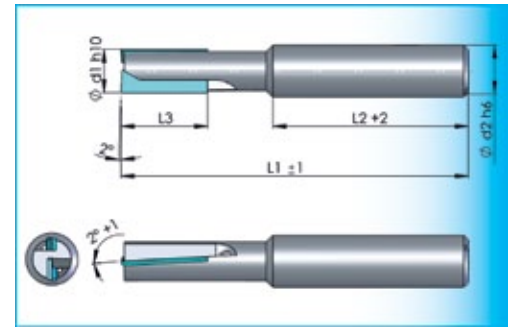

Hinweis: Auch mit 3D-Spanleitstufe lieferbar!

	d1 h10 mm	d2 h6 mm	l1 Gesamtlänge mm	l2 Schaftlänge mm	l3 (PKD-Länge) mm	Artikel-Nr. (code no.)	Preis Euro / je KF920
•	6	8	60	36	10	KF9200601	137,00
•	6	8	80	36	20	KF9200602	196,00
•	8	10	60	40	10	KF9200801	140,80
•	8	10	80	40	20	KF9200802	222,20
•	10	12	70	45	10	KF9201001	152,00
•	10	12	90	45	20	KF9201002	228,80
•	12	14	70	45	10	KF9201201	171,80
•	12	14	90	45	20	KF9201202	253,00
•	14	16	80	48	10	KF9201401	202,60
•	14	16	100	48	20	KF9201402	290,60
•	16	16	90	48	10	KF9201601	226,60
•	16	16	110	48	20	KF9201602	317,00
•	18	20	100	50	10	KF9201801	255,20
•	18	20	120	50	20	KF9201802	356,60
•	20	20	140	50	10	KF9202001	284,00
•	20	20	150	50	20	KF9202002	391,80

## PKD-RADIUSFRÄSER mit Innenkühlung Achswinkel neutral KFB910



Einsatzgebiete: Für die Bearbeitung von NE-Metallen wie Aluminium, Messing, Bronze, Kupfer, GFK, CFK, Graphit und Kohlenstoffe, Duroplaste und Thermoplaste.

application: For machining of non-ferrous metals such as aluminium, brass, bronze, copper, GRP and CFK, graphite and carbons, curable and thermo plastics.



• ab Lager / ex stock • kurzfristig / on short notice • Lieferzeit auf Anfrage / delivery time upon request

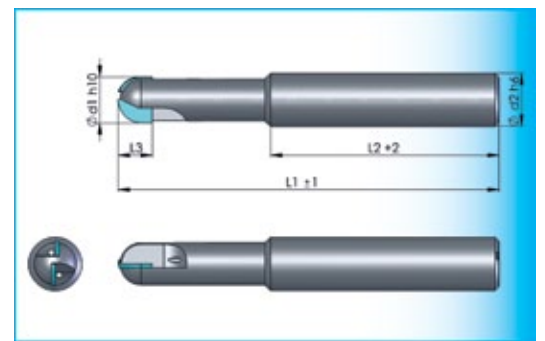

Hinweis: Auch mit 3D-Spanleitstufe lieferbar!

	d1 h10 mm	d2 h6 mm	l1 Gesamtlänge mm	l2 Schaftlänge mm	l3 (PKD-Länge) mm	Artikel-Nr. (code no.)	Preis Euro / je KFB910
•	4	6	75	40	2,5	KFB910040	116,60
•	5	8	75	40	3	KFB910050	118,80
•	6	8	100	60	6	KFB910060	149,80
•	8	10	100	60	7	KFB910080	163,00
•	10	12	100	60	8	KFB910100	191,60
•	12	14	100	60	9	KFB910120	224,40
•	16	16	150	100	11	KFB910160	286,20
•	20	20	150	90	13	KFB910200	387,40

### Vorteile von PKD-Fräsern mit gelasertter 3D-Spanleitstufe:



- geringere Schnittkräfte
- reduzierte Erwärmung am Bauteil
- verringerte Aufbauschneidenbildung
- kurze Späne durch gezielten Spanbruch
- weicherer Schnitt und bessere Oberflächengüten
- längere Standzeiten durch reduzierte Gratbildung

## VHM-SCHAFTFRÄSER MIT ECKENRADIUS

## KF700 - DIAMANT



**Einsatzgebiete:** Mit Diamant-Beschichtung zur Bearbeitung von stark abrasiven Werkstoffen. Insbesondere für Graphit, AlSi-Legierungen (Si>10%) und faserverstärkten Werkstoffen. Ausführung mit abgesetztem Halseinschliff (d3) sowie Eckenradius.

**application:** Diamond-coated to machine very abrasive materials. Especially suited for graphite, AlSi-alloys (Si>10%) and fiber-reinforced materials. With reduced shank (d3) and edge radius.



Diamant-beschichtete Vollhartmetallfräser sind auch in anderen Längen und Durchmessern erhältlich.  
Diamond-coated solid carbide end mills are available with other lengths and diameters upon request.

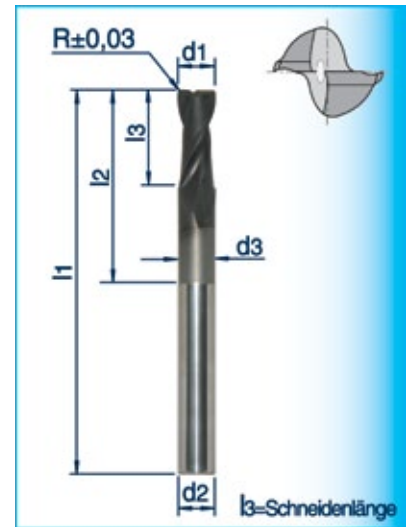

- ab Lager / ex stock
- kurzfristig / on short notice
- Lieferzeit ca. 1-2 Wochen / delivery time approx. 1-2 weeks

d1	d2	Radius	d3	l1	l2	l3	Zähnezahl	Artikel-Nr.	Preis
h10	h6	R					(no. of	(code no.)	Euro / je
mm	mm	±0,03	mm	mm	mm	mm	cutting edges)		KF700
• 2,0	3,0	0,5	1,9	50,0	12,0	6,0	2	KF700020DIA1	47,00
• 2,0	3,0	0,5	1,9	100,0	20,0	10,0	2	KF700020DIA2	50,00
• 3,0	3,0	0,5	2,9	60,0	16,0	8,0	2	KF700030DIA1	48,00
• 3,0	3,0	0,5	2,9	100,0	24,0	12,0	2	KF700030DIA2	50,00
• 4,0	4,0	0,5	3,8	60,0	20,0	10,0	2	KF700040DIA1	61,80
• 4,0	4,0	0,5	3,8	100,0	30,0	15,0	2	KF700040DIA2	64,20
• 5,0	5,0	0,5	4,8	60,0	24,0	12,0	2	KF700050DIA1	75,80
• 5,0	5,0	0,5	4,8	100,0	30,0	15,0	2	KF700050DIA2	80,80
• 6,0	6,0	0,5	5,8	75,0	40,0	20,0	2	KF700060DIA1	84,00
• 6,0	6,0	0,5	5,8	100,0	50,0	25,0	2	KF700060DIA2	90,00
• 6,0	6,0	0,5	5,8	150,0	60,0	30,0	2	KF700060DIA3	99,00
• 8,0	8,0	1,0	7,8	75,0	40,0	20,0	2	KF700080DIA1	111,00
• 8,0	8,0	1,0	7,8	100,0	50,0	25,0	2	KF700080DIA2	119,40
• 8,0	8,0	1,0	7,8	150,0	60,0	30,0	2	KF700080DIA3	133,00
• 10,0	10,0	1,0	9,8	100,0	50,0	25,0	2	KF700100DIA1	154,00
• 10,0	10,0	1,0	9,8	150,0	60,0	30,0	2	KF700100DIA2	169,00
• 12,0	12,0	1,0	11,8	100,0	50,0	25,0	2	KF700120DIA1	181,60
• 12,0	12,0	1,0	11,8	150,0	80,0	40,0	2	KF700120DIA2	211,60
• 16,0	16,0	1,5	15,8	100,0	50,0	25,0	2	KF700160DIA1	277,20
• 16,0	16,0	1,5	15,8	150,0	80,0	40,0	2	KF700160DIA2	310,00

## VHM-RADIUSFRÄSER

## KFB700 - DIAMANT



**Einsatzgebiete:** Mit Diamant-Beschichtung zur Bearbeitung von stark abrasiven Werkstoffen. Insbesondere für Graphit, AlSi-Legierungen (Si>10%) und faserverstärkten Werkstoffen. Ausführung mit abgesetztem Halseinschliff (d3) sowie Eckenradius.

**application:** Diamond-coated to machine very abrasive materials. Especially suited for graphite, AlSi-alloys (Si>10%) and fiber-reinforced materials. With reduced shank (d3) and edge radius.



Diamant-beschichtete Vollhartmetallfräser sind auch in anderen Längen und Durchmessern erhältlich.  
Diamond-coated solid carbide end mills are available with other lengths and diameters upon request.

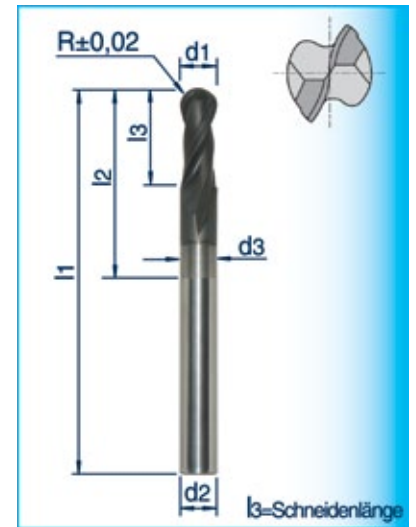

- ab Lager / ex stock
- kurzfristig / on short notice
- Lieferzeit ca. 1-2 Wochen / delivery time approx. 1-2 weeks

d1	d2	d3	l1	l2	l3	Zähnezahl (no. of cutting edges)	Artikel-Nr. (code no.)	Preis Euro / je KFB700
h10 mm	h6 mm	mm	mm	mm	mm			
• 2,0	3,0	1,9	50,0	12,0	6,0	2	KFB700020DI1	47,00
• 2,0	3,0	1,9	100,0	20,0	10,0	2	KFB700020DI2	50,00
• 3,0	3,0	2,9	60,0	16,0	8,0	2	KFB700030DI1	48,00
• 3,0	3,0	2,9	100,0	24,0	12,0	2	KFB700030DI2	50,00
• 4,0	4,0	3,8	60,0	20,0	10,0	2	KFB700040DI1	61,80
• 4,0	4,0	3,8	100,0	30,0	15,0	2	KFB700040DI2	64,20
• 5,0	5,0	4,8	60,0	24,0	12,0	2	KFB700050DI1	75,80
• 5,0	5,0	4,8	100,0	30,0	15,0	2	KFB700050DI2	80,80
• 6,0	6,0	5,8	75,0	40,0	20,0	2	KFB700060DI1	84,00
• 6,0	6,0	5,8	100,0	50,0	25,0	2	KFB700060DI2	90,00
• 6,0	6,0	5,8	150,0	60,0	30,0	2	KFB700060DI3	99,00
• 8,0	8,0	7,8	75,0	40,0	20,0	2	KFB700080DI1	111,00
• 8,0	8,0	7,8	100,0	50,0	25,0	2	KFB700080DI2	119,40
• 8,0	8,0	7,8	150,0	60,0	30,0	2	KFB700080DI3	133,00
• 10,0	10,0	9,8	100,0	50,0	25,0	2	KFB700100DI1	154,00
• 10,0	10,0	9,8	150,0	60,0	30,0	2	KFB700100DI2	169,00
• 12,0	12,0	11,8	100,0	50,0	25,0	2	KFB700120DI1	181,60
• 12,0	12,0	11,8	150,0	80,0	40,0	2	KFB700120DI2	211,60
• 16,0	16,0	15,8	100,0	50,0	25,0	2	KFB700160DI1	277,20
• 16,0	16,0	15,8	150,0	80,0	40,0	2	KFB700160DI2	310,00

## VHM-SCHRUPPFÄSER

## KF310 / KF311 / KFB311 - ZX3



**Einsatzgebiete:** Höchste Zerspanleistung durch Feinkornprofil in Verbindung mit verstärktem Kern, Substrat K50F und ZX3-Beschichtung. Für Stahlwerkstoffe, gehärtete Stähle und Gußwerkstoffe.

**application:** Highest cutting performance due to the fine-knurled profile in connection with the reinforced web, substrate K50F and ZX3-coating. For steel materials, hardened steel and cast materials.

KF310 = 3-5 Schneiden, kurze Ausführung, Zylinderschaft DIN6535-HB (Weldon-Spannfläche)  
 KF311 = 3-5 Schneiden, lange Ausführung, Zylinderschaft DIN6535-HB (Weldon-Spannfläche)  
 KFB311 = 3-4 Schneiden, lange Ausführung, Zylinderschaft DIN6535-HA



• ab Lager / ex stock • kurzfristig / on short notice • Lieferzeit auf Anfrage / delivery time upon request



### VHM-Schruppfäser KF310 - kurze Ausführung - Weldon-Spannfläche

d1 h10 mm	d2 h6 mm	l2 mm	l1 mm	Zähnezahl (no. of cutting edges)	Artikel-Nr. (code no.)	Preis Euro / je KF310 - ZX3
• 6,0	6,0	7,0	54,0	3	KF310060ZX3	24,20
• 7,0	8,0	8,0	58,0	3	KF310070ZX3	28,20
• 8,0	8,0	9,0	58,0	3	KF310080ZX3	28,20
• 9,0	10,0	13,0	66,0	4	KF310090ZX3	42,40
• 10,0	10,0	14,0	66,0	4	KF310100ZX3	42,40
• 12,0	12,0	16,0	73,0	4	KF310120ZX3	54,00
• 14,0	14,0	18,0	75,0	4	KF310140ZX3	65,80
• 16,0	16,0	22,0	82,0	4	KF310160ZX3	88,20
• 18,0	18,0	24,0	84,0	4	KF310180ZX3	113,20
• 20,0	20,0	26,0	92,0	4	KF310200ZX3	142,00
• 25,0	25,0	25,0	110,0	5	KF310250ZX3	249,20

### VHM-Schruppfäser KF311 - lange Ausführung - Weldon-Spannfläche

d1 h10 mm	d2 h6 mm	l2 mm	l1 mm	Zähnezahl (no. of cutting edges)	Artikel-Nr. (code no.)	Preis Euro / je KF311 - ZX3
• 6,0	6,0	16,0	57,0	3	KF311060ZX3	26,40
• 7,0	8,0	16,0	63,0	3	KF311070ZX3	30,40
• 8,0	8,0	16,0	63,0	3	KF311080ZX3	30,40
• 9,0	10,0	19,0	72,0	4	KF311090ZX3	45,40
• 10,0	10,0	22,0	72,0	4	KF311100ZX3	45,40
• 12,0	12,0	26,0	83,0	4	KF311120ZX3	58,20
• 14,0	14,0	26,0	83,0	4	KF311140ZX3	70,80
• 16,0	16,0	32,0	92,0	4	KF311160ZX3	94,80
• 18,0	18,0	32,0	92,0	4	KF311180ZX3	122,00
• 20,0	20,0	38,0	104,0	4	KF311200ZX3	152,80
• 25,0	25,0	45,0	121,0	5	KF311250ZX3	267,60

### VHM-Radius-Schruppfäser KFB311 - lange Ausführung

d1 h10 mm	d2 h6 mm	Radius R $\pm 0,02$	l2 mm	l1 mm	Zähnezahl (no. of cutting edges)	Artikel-Nr. (code no.)	Preis Euro / je KFB311 - ZX3
• 6,0	6,0	3,0	16,0	57,0	3	KFB311060ZX3	40,20
• 8,0	8,0	4,0	16,0	63,0	3	KFB311080ZX3	46,80
• 10,0	10,0	5,0	22,0	72,0	4	KFB311100ZX3	69,80
• 12,0	12,0	6,0	26,0	83,0	4	KFB311120ZX3	89,60
• 14,0	14,0	7,0	26,0	83,0	4	KFB311140ZX3	108,40
• 16,0	16,0	8,0	32,0	92,0	4	KFB311160ZX3	145,60
• 18,0	18,0	9,0	32,0	92,0	4	KFB311180ZX3	186,60
• 20,0	20,0	10,0	38,0	104,0	4	KFB311200ZX3	234,60

## VHM-SCHRUPP-SCHLICHTFRÄSER

## KF306 - ZX5



Einsatzgebiete: Zum Schrubb- und Schlichtfräsen mit extrem hohen Vorschüben in Stahl und NE-Metallen. Das spezielle Trapezprofil bietet im Einsatz hohe Zerspanungsleistung, doppelte Standzeit und sehr gute Oberflächengüten.

application: For roughing and finishing operations with extremely high feeds in steel and nonferrous metals. The special trapezoidal profile ensures high cutting performance, duplication of tool life and very good surface qualities.

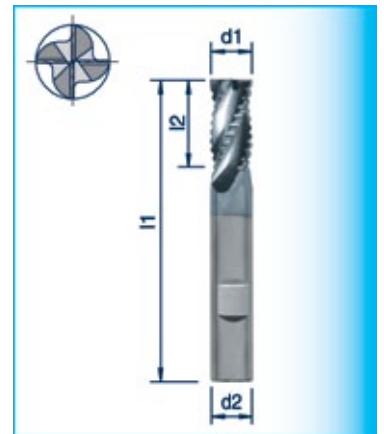

• ab Lager / ex stock • kurzfristig / on short notice • Lieferzeit auf Anfrage / delivery time upon request

d1 h10 mm	d2 h6 mm	l2 mm	l1 mm	Zähnezahl (no. of cutting edges)	Artikel-Nr. (code no.)	Preis Euro / je KF306 - ZX5
• 6,0	6,0	13,0	57,0	3	KF306060TIC	39,40
• 8,0	8,0	19,0	63,0	3	KF306080TIC	48,80
• 10,0	10,0	22,0	72,0	4	KF306100TIC	53,40
• 12,0	12,0	26,0	83,0	4	KF306120TIC	67,20
• 14,0	14,0	26,0	83,0	4	KF306140TIC	86,20
• 16,0	16,0	32,0	92,0	4	KF306160TIC	101,20
• 18,0	18,0	32,0	96,0	4	KF306180TIC	138,00
• 20,0	20,0	38,0	104,0	4	KF306200TIC	152,80

## VHM-SCHRUPPFRÄSER MIT INNENKÜHLUNG

## KF319 - ZX4



Einsatzgebiete: Für Stahlwerkstoffe, rost- und säurebeständige Stähle sowie für Gußwerkstoffe.

application: For steel materials, rust- and acid-resistant steels as well as for casting materials.

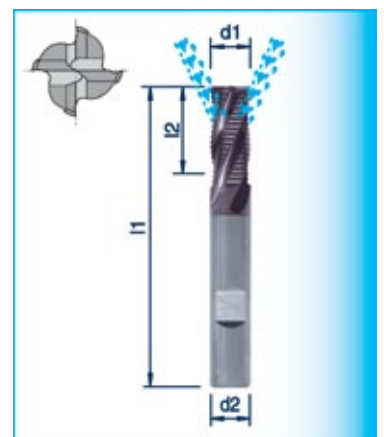

• ab Lager / ex stock • kurzfristig / on short notice • Lieferzeit auf Anfrage / delivery time upon request

d1 h10 mm	d2 h6 mm	l2 mm	l1 mm	Zähnezahl (no. of cutting edges)	Artikel-Nr. (code no.)	Preis Euro / je KF319 - ZX4
• 6,0	6,0	13,0	57,0	4	KF319060ZX4	45,40
• 8,0	8,0	19,0	63,0	4	KF319080ZX4	50,40
• 10,0	10,0	22,0	72,0	4	KF319100ZX4	55,20
• 12,0	12,0	26,0	83,0	4	KF319120ZX4	74,60
• 16,0	16,0	32,0	92,0	4	KF319160ZX4	104,20
• 20,0	20,0	38,0	104,0	4	KF319200ZX4	154,20

## VHM-UNIVERSAL-TOOL 90°

## KF620 - ZX3



**Einsatzgebiete:** Das Universal-Tool ist konzipiert zum Fräsen, Bohren und Senken mit nur einem Werkzeug. Bis zu 8 Bearbeitungsvorgänge ohne Werkzeugwechsel sind möglich. Werkzeugrüstzeiten und Werkzeugbevorratung werden eingespart.

**application:** This universal tool is constructed to mill, bore and countersink all in one. Up to 8 machining operations are possible without changing the tool. You save set-up time and stockkeeping.

### Hinweis/Einsatzempfehlung:

unbeschichtet K15F



ZX3-(TiAlN)-beschichtet

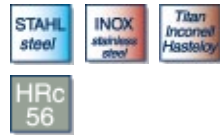

- ab Lager / ex stock
- kurzfristig / on short notice
- Lieferzeit auf Anfrage / delivery time upon request

d1 0/-0,01 mm	d2 h6 mm	z	l1 mm	l2 mm	Spitze α	T mm	Artikel-Nr. (code no.) unbeschichtet	Preis Euro / je unbeschichtet	Artikel-Nr. (code no.) ZX3	Preis Euro / je ZX3
0,50	3,0	2	39	1,0	90°	0,05	KF620005	18,80	KF620005ZX3	21,40
0,60	3,0	2	39	1,2	90°	0,06	KF620006	18,80	KF620006ZX3	21,40
0,70	3,0	2	39	1,4	90°	0,07	KF620007	18,80	KF620007ZX3	21,40
0,80	3,0	2	39	1,6	90°	0,08	KF620008	18,80	KF620008ZX3	21,40
0,90	3,0	2	39	1,8	90°	0,09	KF620009	18,80	KF620009ZX3	21,40
1,00	3,0	2	39	2,0	90°	0,10	KF620010	18,80	KF620010ZX3	21,40
1,20	3,0	2	39	2,4	90°	0,12	KF620012	18,80	KF620012ZX3	21,40
1,40	3,0	2	39	2,8	90°	0,14	KF620014	18,80	KF620014ZX3	21,40
1,50	3,0	2	39	3,0	90°	0,15	KF620015	18,80	KF620015ZX3	21,40
1,80	3,0	2	39	3,6	90°	0,18	KF620018	18,80	KF620018ZX3	21,40
2,00	3,0	2	39	4,0	90°	0,20	KF620020	18,80	KF620020ZX3	21,40
2,50	3,0	2	39	5,0	90°	0,25	KF620025	18,80	KF620025ZX3	21,40
3,00	4,0	2	50	6,0	90°	0,30	KF620030	24,80	KF620030ZX3	26,80
4,00	5,0	2	50	8,0	90°	0,40	KF620040	25,80	KF620040ZX3	30,20
5,00	6,0	2	50	10,0	90°	0,50	KF620050	27,20	KF620050ZX3	29,40
6,00	8,0	2	60	12,0	90°	0,60	KF620060	33,40	KF620060ZX3	35,80
8,00	10,0	2	70	16,0	90°	0,80	KF620080	46,40	KF620080ZX3	49,80
10,00	12,0	2	70	18,0	90°	1,00	KF620100	59,60	KF620100ZX3	63,80
12,00	12,0	2	70	20,0	90°	1,20	KF620120	57,80	KF620120ZX3	62,80
16,00	16,0	2	80	26,0	90°	1,60	KF620160	83,40	KF620160ZX3	90,80
20,00	20,0	2	100	32,0	90°	2,00	KF620200	144,40	KF620200ZX3	155,20

### Anwendungsmöglichkeiten:

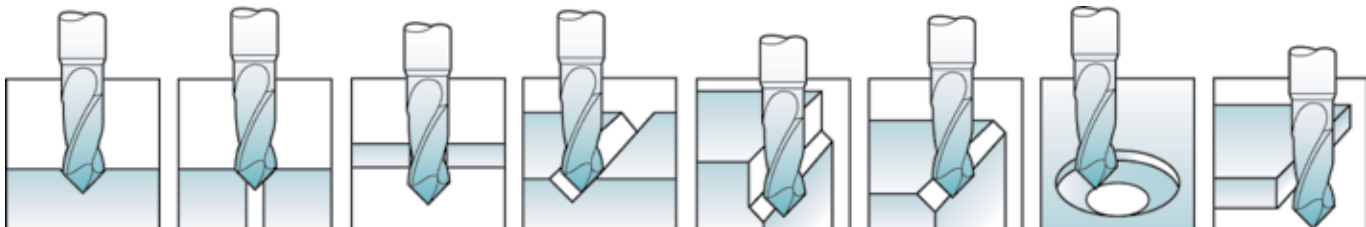

## VHM-UNIVERSAL-TOOL

## KF621 (60°) / KF622 (120°) - ZX3



**Einsatzgebiete:** Das Universal-Tool ist konzipiert zum Fräsen, Bohren und Senken mit nur einem Werkzeug. Bis zu 8 Bearbeitungsvorgänge ohne Werkzeugwechsel sind möglich. Werkzeugrüstzeiten und Werkzeugbevorratung werden eingespart.

**application:** This universal tool is constructed to mill, bore and countersink all in one. Up to 8 machining operations are possible without changing the tool. You save set-up time and stockkeeping.

### Hinweis/Einsatzempfehlung:

unbeschichtet K15F



ZX3-(TiAlN)-beschichtet

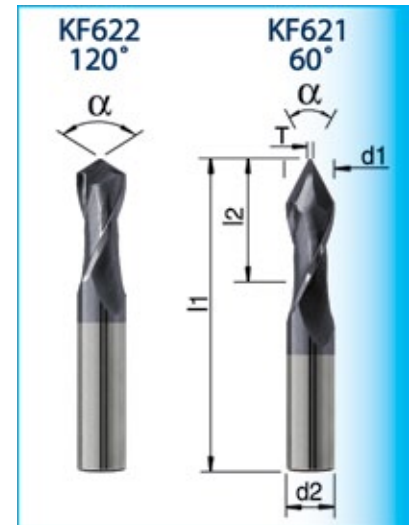
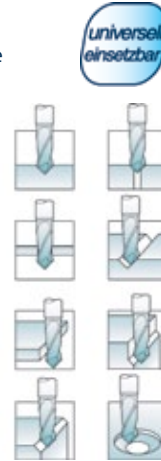

- ab Lager / ex stock
- kurzfristig / on short notice
- Lieferzeit auf Anfrage / delivery time upon request

### VHM-Universal-Tool 60°

d1 0/-0,01 mm	d2 h6 mm	z	l1 mm	l2 mm	Spitze α	T mm	Artikel-Nr. (code no.) unbeschichtet	Preis Euro / je unbeschichtet	Artikel-Nr. (code no.) ZX3	Preis Euro / je ZX3
0,50	3,0	2	39	2,0	60°	0,05	KF621005	38,60	KF621005ZX3	---
1,00	3,0	2	39	2,0	60°	0,10	KF621010	23,40	KF621010ZX3	26,00
1,50	3,0	2	39	3,0	60°	0,15	KF621015	23,40	KF621015ZX3	26,00
2,00	3,0	2	39	4,0	60°	0,20	KF621020	23,40	KF621020ZX3	26,00
2,50	3,0	2	39	5,0	60°	0,25	KF621025	23,40	KF621025ZX3	26,00
3,00	4,0	2	50	6,0	60°	0,30	KF621030	30,60	KF621030ZX3	33,00
4,00	5,0	2	50	8,0	60°	0,40	KF621040	32,00	KF621040ZX3	34,40
5,00	6,0	2	50	10,0	60°	0,50	KF621050	34,20	KF621050ZX3	36,00
6,00	8,0	2	60	12,0	60°	0,60	KF621060	41,80	KF621060ZX3	44,00
8,00	10,0	2	70	16,0	60°	0,80	KF621080	57,80	KF621080ZX3	61,60
10,00	12,0	2	70	18,0	60°	1,00	KF621100	74,40	KF621100ZX3	78,80
12,00	12,0	2	70	20,0	60°	1,20	KF621120	72,40	KF621120ZX3	77,40
16,00	16,0	2	80	26,0	60°	1,60	KF621160	104,60	KF621160ZX3	112,40
20,00	20,0	2	100	32,0	60°	2,00	KF621200	180,40	KF621200ZX3	191,60

### VHM-Universal-Tool 120°

d1 0/-0,01 mm	d2 h6 mm	z	l1 mm	l2 mm	Spitze α	T mm	Artikel-Nr. (code no.) unbeschichtet	Preis Euro / je unbeschichtet	Artikel-Nr. (code no.) ZX3	Preis Euro / je ZX3
1,00	3,0	2	39	2,0	120°	0,10	KF622010	18,80	KF622010ZX3	21,40
1,50	3,0	2	39	3,0	120°	0,15	KF622015	18,80	KF622015ZX3	21,40
2,00	3,0	2	39	4,0	120°	0,20	KF622020	18,80	KF622020ZX3	21,40
2,50	3,0	2	39	5,0	120°	0,25	KF622025	18,80	KF622025ZX3	21,40
3,00	4,0	2	50	6,0	120°	0,30	KF622030	24,80	KF622030ZX3	26,80
4,00	5,0	2	50	8,0	120°	0,40	KF622040	25,80	KF622040ZX3	28,00
5,00	6,0	2	50	10,0	120°	0,50	KF622050	27,20	KF622050ZX3	29,40
6,00	8,0	2	60	12,0	120°	0,60	KF622060	33,20	KF622060ZX3	35,80
8,00	10,0	2	70	16,0	120°	0,80	KF622080	46,40	KF622080ZX3	49,80
10,00	12,0	2	70	18,0	120°	1,00	KF622100	59,60	KF622100ZX3	63,80
12,00	12,0	2	70	20,0	120°	1,20	KF622120	57,80	KF622120ZX3	62,80
16,00	16,0	2	80	26,0	120°	1,60	KF622160	83,40	KF622160ZX3	90,80
20,00	20,0	2	100	32,0	120°	2,00	KF622200	144,40	KF622200ZX3	155,20

## VHM-MICRO-SCHAFTFRÄSER

## KF350 (1,5xØ)



Einsatzgebiete: Universell einsetzbar, sowohl für den Dentalbereich, Kleinstformenbau, Uhren- und Schmuckindustrie sowie zum Fräsen von Elektroden. Extrakurze, stabile Ausführung.

application: Universal applications. Well suited for dental, jewelry and miniature mould making industry as well as for the machining of electrodes. Extreme short, stable construction.

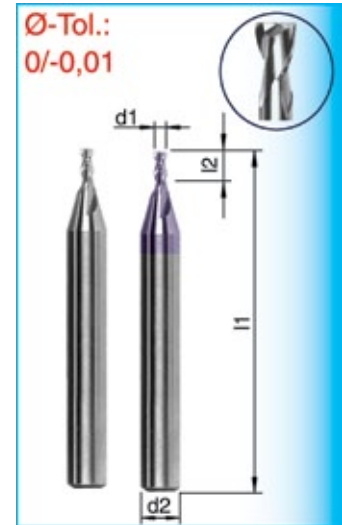

### Hinweis/Einsatzempfehlung:

#### unbeschichtet K15F



#### ZX3-(TiAlN)-beschichtet



#### Diamant-beschichtet



• ab Lager / ex stock • kurzfristig / on short notice • Lieferzeit ca. 1-2 Wochen / delivery time approx. 1-2 weeks

d1 0/-0,01	d2 h6	z	l1	l2	Artikel-Nr. unbeschichtet (uncoated)	Preis Euro / je unbeschichtet (uncoated)	Artikel-Nr. (code no.) ZX3	Preis Euro / je ZX3	Artikel-Nr. (code no.) Diamant	Preis Euro / je Diamant
0,10	3	2	39	0,10	KF3500010	44,80		---		---
0,15	3	2	39	0,20	KF3500015	37,60		---		---
0,20	3	2	39	0,30	KF3500020	32,00		---		---
0,25	3	2	39	0,35	KF3500025	32,00		---		---
0,30	3	2	39	0,45	KF3500030	19,00	KF3500030ZX3	21,60	KF3500030DIA	48,80
0,40	3	2	39	0,60	KF3500040	15,20	KF3500040ZX3	18,00	KF3500040DIA	45,00
0,50	3	2	39	0,75	KF3500050	13,20	KF3500050ZX3	16,20	KF3500050DIA	43,00
0,60	3	2	39	0,90	KF3500060	13,20	KF3500060ZX3	16,20	KF3500060DIA	43,00
0,70	3	2	39	1,05	KF3500070	13,20	KF3500070ZX3	16,20	KF3500070DIA	43,00
0,80	3	2	39	1,20	KF3500080	13,20	KF3500080ZX3	16,20	KF3500080DIA	43,00
0,90	3	2	39	1,35	KF3500090	13,20	KF3500090ZX3	16,20	KF3500090DIA	43,00
1,00	3	2	39	1,50	KF3500100	13,20	KF3500100ZX3	16,20	KF3500100DIA	43,00
1,10	3	2	39	1,65	KF3500110	13,20	KF3500110ZX3	16,20	KF3500110DIA	43,00
1,20	3	2	39	1,80	KF3500120	13,20	KF3500120ZX3	16,20		---
1,30	3	2	39	1,95	KF3500130	14,40	KF3500130ZX3	17,40		---
1,40	3	2	39	2,10	KF3500140	14,40	KF3500140ZX3	17,40		---
1,50	3	2	39	2,25	KF3500150	14,40	KF3500150ZX3	17,40	KF3500150DIA	44,20
1,60	3	2	39	2,40	KF3500160	15,20	KF3500160ZX3	18,00	KF3500160DIA	54,80
1,70	3	2	39	2,55	KF3500170	15,20	KF3500170ZX3	18,00		---
1,80	3	2	39	2,70	KF3500180	15,20	KF3500180ZX3	18,00	KF3500180DIA	54,80
1,90	3	2	39	2,85	KF3500190	15,20	KF3500190ZX3	18,00		---
2,00	3	2	39	3,00	KF3500200	14,40	KF3500200ZX3	17,40	KF3500200DIA	54,00

# VHM-MICRO-SCHAFTFRÄSER

# KF351 (2-3xØ)



Einsatzgebiete: Universell einsetzbar, sowohl für den Dentalbereich, Kleinstformenbau, Uhren- und Schmuckindustrie sowie zum Fräsen von Elektroden. Eingriffstiefe bis 3 x Ø.

application: Universal applications. Well suited for dental, jewelry and miniature mould making industry as well as for the machining of electrodes. Working depth up to 3 x dia.

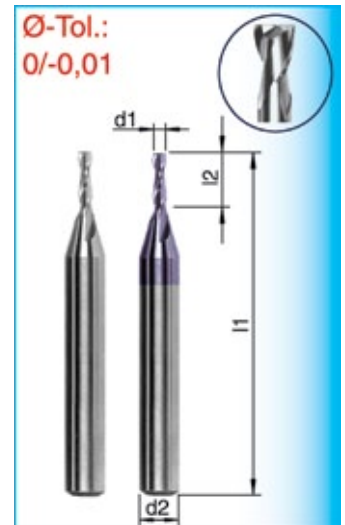

### Hinweis/Einsatzempfehlung:

#### unbeschichtet K15F



#### ZX3-(TiAlN)-beschichtet



#### Diamant-beschichtet



• ab Lager / ex stock • kurzfristig / on short notice • Lieferzeit ca. 1-2 Wochen / delivery time approx. 1-2 weeks

d1 0/-0,01	d2 h6	z	l1	l2	Artikel-Nr. unbeschichtet (uncoated)	Preis Euro / je unbeschichtet (uncoated)	Artikel-Nr. (code no.) ZX3	Preis Euro / je ZX3	Artikel-Nr. (code no.) Diamant	Preis Euro / je Diamant
0,10	3,0	2	39	0,2	KF3510010	44,80		---		---
0,15	3,0	2	39	0,3	KF3510015	37,60		---		---
0,20	3,0	2	39	0,5	KF3510020	32,00		---		---
0,25	3,0	2	39	0,5	KF3510025	32,00		---		---
0,30	3,0	2	39	1,0	KF3510030	19,00	KF3510030ZX3	21,60	KF3510030DIA	48,80
0,35	3,0	2	39	1,0	KF3510035	19,00	KF3510035ZX3	21,60		---
0,40	3,0	2	39	1,0	KF3510040	15,20	KF3510040ZX3	18,00	KF3510040DIA	45,00
0,45	3,0	2	39	1,0	KF3510045	22,40	KF3510045ZX3	25,00		---
0,50	3,0	2	39	1,5	KF3510050	13,20	KF3510050ZX3	16,20	KF3510050DIA	43,00
0,55	3,0	2	39	1,5	KF3510055	17,40	KF3510055ZX3	20,20		---
0,60	3,0	2	39	1,5	KF3510060	13,20	KF3510060ZX3	16,20	KF3510060DIA	43,00
0,65	3,0	2	39	1,5	KF3510065	17,40	KF3510065ZX3	20,20		---
0,70	3,0	2	39	2,0	KF3510070	13,20	KF3510070ZX3	16,20	KF3510070DIA	43,00
0,75	3,0	2	39	2,0	KF3510075	17,40	KF3510075ZX3	20,20		---
0,80	3,0	2	39	2,0	KF3510080	13,20	KF3510080ZX3	16,20	KF3510080DIA	43,00
0,85	3,0	2	39	2,0	KF3510085	17,40	KF3510085ZX3	20,20		---
0,90	3,0	2	39	2,5	KF3510090	13,20	KF3510090ZX3	16,20	KF3510090DIA	43,00
0,95	3,0	2	39	2,5	KF3510095	17,40	KF3510095ZX3	20,20		---
1,00	3,0	2	39	3,0	KF3510100	13,20	KF3510100ZX3	16,20	KF3510100DIA	43,00
1,05	3,0	2	39	3,0	KF3510105	17,40	KF3510105ZX3	20,20		---
1,10	3,0	2	39	3,0	KF3510110	13,20	KF3510110ZX3	16,20		---
1,15	3,0	2	39	3,0	KF3510115	17,40	KF3510115ZX3	20,20		---
1,20	3,0	2	39	4,0	KF3510120	13,20	KF3510120ZX3	16,20	KF3510120DIA	43,00
1,25	3,0	2	39	4,0	KF3510125	17,40	KF3510125ZX3	20,20		---
1,30	3,0	2	39	4,0	KF3510130	14,40	KF3510130ZX3	17,40		---
1,40	3,0	2	39	4,0	KF3510140	14,40	KF3510140ZX3	17,40	KF3510140DIA	44,20
1,50	3,0	2	39	4,0	KF3510150	14,40	KF3510150ZX3	17,40	KF3510150DIA	44,20
1,60	3,0	2	39	5,0	KF3510160	15,20	KF3510160ZX3	18,00	KF3510160DIA	54,80
1,70	3,0	2	39	5,0	KF3510170	15,20	KF3510170ZX3	18,00		---
1,80	3,0	2	39	5,0	KF3510180	15,20	KF3510180ZX3	18,00	KF3510180DIA	54,80
1,90	3,0	2	39	5,0	KF3510190	15,20	KF3510190ZX3	18,00		---
2,00	3,0	2	39	5,0	KF3510200	14,40	KF3510200ZX3	17,40	KF3510200DIA	54,00
2,10	3,0	2	39	6,0	KF3510210	16,00	KF3510210ZX3	18,80	KF3510210DIA	55,60
2,20	3,0	2	39	6,0	KF3510220	16,00	KF3510220ZX3	18,80	KF3510220DIA	55,60
2,30	3,0	2	39	6,0	KF3510230	16,00	KF3510230ZX3	18,80	KF3510230DIA	55,60
2,40	3,0	2	39	6,0	KF3510240	16,00	KF3510240ZX3	18,80	KF3510240DIA	55,60
2,50	3,0	2	39	7,0	KF3510250	16,00	KF3510250ZX3	18,80	KF3510250DIA	55,60
2,60	3,0	2	39	7,0	KF3510260	19,00	KF3510260ZX3	21,60	KF3510260DIA	48,80
2,70	3,0	2	39	7,0	KF3510270	19,00	KF3510270ZX3	21,60	KF3510270DIA	48,80
2,80	3,0	2	39	7,0	KF3510280	19,00	KF3510280ZX3	21,60	KF3510280DIA	48,80
2,90	3,0	2	39	7,0	KF3510290	19,00	KF3510290ZX3	21,60	KF3510290DIA	48,80
3,00	4,0	2	44	10,0	KF3510300	19,00	KF3510300ZX3	21,00	KF3510300DIA	48,80

## VHM-MICRO-SCHAFTFRÄSER

## KF352(5xØ) / KF353(8xØ)



Einsatzgebiete: Universell einsetzbar, sowohl für den Dentalbereich, Kleinstformenbau, Uhren- und Schmuckindustrie sowie zum Fräsen von Elektroden. Eingriffstiefe bis 8 x Ø.

application: Universal applications. Well suited for dental, jewelry and miniature mould making industry as well as for the machining of electrodes. Working depth up to 8 x dia.



### Hinweis/Einsatzempfehlung:

#### unbeschichtet K15F



#### ZX3-(TiAlN)-beschichtet



#### Diamant-beschichtet



• ab Lager / ex stock • kurzfristig / on short notice • Lieferzeit ca. 1-2 Wochen / delivery time approx. 1-2 weeks

### VHM-Microfräser KF352 - 5xØ

d1 0/-0,01	d2 h6	z	l1	l2	Artikel-Nr. unbeschichtet (uncoated)	Preis Euro / je unbeschichtet (uncoated)	Artikel-Nr. (code no.) ZX3	Preis Euro / je ZX3	Artikel-Nr. (code no.) Diamant	Preis Euro / je Diamant
0,40	3,0	2	39	2,0	KF3520040	38,20	KF3520040ZX3	42,40	KF3520040DIA	45,00
0,50	3,0	2	39	2,5	KF3520050	34,40	KF3520050ZX3	38,40	KF3520050DIA	45,00
0,60	3,0	2	39	3,0	KF3520060	33,40	KF3520060ZX3	37,80	KF3520060DIA	45,00
0,70	3,0	2	39	3,5	KF3520070	32,80	KF3520070ZX3	36,80	KF3520070DIA	45,00
0,80	3,0	2	39	4,0	KF3520080	32,00	KF3520080ZX3	36,00	KF3520080DIA	44,20
0,90	3,0	2	39	4,5	KF3520090	32,00	KF3520090ZX3	36,00	KF3520090DIA	44,20
1,00	3,0	2	39	5,0	KF3520100	32,00	KF3520100ZX3	36,00	KF3520100DIA	44,20
1,20	3,0	2	39	6,0	KF3520120	32,00	KF3520120ZX3	36,00	KF3520120DIA	44,20
1,50	3,0	2	39	7,5	KF3520150	32,00	KF3520150ZX3	36,00	KF3520150DIA	49,20
2,00	3,0	2	39	10,0	KF3520200	32,00	KF3520200ZX3	36,00	KF3520200DIA	54,00

### VHM-Microfräser KF353 - 8xØ

d1 0/-0,01	d2 h6	z	l1	l2	Artikel-Nr. unbeschichtet (uncoated)	Preis Euro / je unbeschichtet (uncoated)	Artikel-Nr. (code no.) ZX3	Preis Euro / je ZX3	Artikel-Nr. (code no.) Diamant	Preis Euro / je Diamant
0,50	3,0	2	39	4,0	KF3530050	40,40	KF3530050ZX3	48,60	KF3530050DIA	70,20
0,60	3,0	2	39	5,0	KF3530060	38,40	KF3530060ZX3	46,80	KF3530060DIA	68,20
0,80	3,0	2	39	6,0	KF3530080	38,40	KF3530080ZX3	46,80	KF3530080DIA	68,20
1,00	3,0	2	39	8,0	KF3530100	40,40	KF3530100ZX3	48,60	KF3530100DIA	70,20
1,20	3,0	2	39	9,0	KF3530120	40,40	KF3530120ZX3	50,20	KF3530120DIA	70,20
1,50	4,0	2	44	12,0	KF3530150	49,60	KF3530150ZX3	58,60	KF3530150DIA	105,00
2,00	4,0	2	44	16,0	KF3530200	51,20	KF3530200ZX3	61,00	KF3530200DIA	106,80
2,50	5,0	2	60	20,0	KF3530250	62,20	KF3530250ZX3	72,80		---
3,00	5,0	2	60	24,0	KF3530300	65,80	KF3530300ZX3	75,20		---

# VHM-MICRO-SCHAFTFRÄSER

# KF354 (Eingriffstiefe bis 15mm)



Einsatzgebiete: Universell einsetzbar, sowohl für den Dentalbereich, Kleinstformenbau, Uhren- und Schmuckindustrie sowie zum Fräsen von Elektroden. Mit freigestelltem Hals für besonders schwer zugängliche Stellen.

application: Universal applications. Well suited for dental, jewelry and miniature mould making industry as well as for the machining of electrodes.

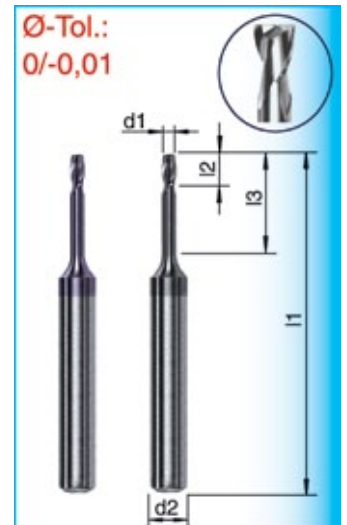

### Hinweis/Einsatzempfehlung:

unbeschichtet K15F



ZX3-(TiAlN)-beschichtet



Diamant-beschichtet



• ab Lager / ex stock • kurzfristig / on short notice • Lieferzeit ca. 1-2 Wochen / delivery time approx. 1-2 weeks

d1 0/-0,01	d2 h6	z	l1	l2	l3	Artikel-Nr. unbeschichtet (uncoated)	Preis Euro / je unbeschichtet (uncoated)	Artikel-Nr. (code no.) ZX3	Preis Euro / je ZX3	Artikel-Nr. (code no.) Diamant	Preis Euro / je Diamant
0,40	3,0	2	39	0,60	2	KF35400401	32,00	KF35400401ZX	35,40	KF35400401DI	53,80
0,50	3,0	2	39	0,75	2	KF35400501	32,00	KF35400501ZX	35,40	KF35400501DI	53,80
0,50	3,0	2	39	0,75	4	KF35400502	32,00	KF35400502ZX	35,40	KF35400502DI	53,80
0,50	3,0	2	60	0,75	6	KF35400503	49,00	KF35400503ZX	53,20	KF35400503DI	76,80
0,60	3,0	2	39	0,90	4	KF35400601	32,00	KF35400601ZX	35,40	KF35400601DI	53,80
0,70	3,0	2	39	1,05	4	KF35400701	32,00	KF35400701ZX	35,40	KF35400701DI	53,80
0,80	3,0	2	39	1,20	4	KF35400801	32,00	KF35400801ZX	35,40	KF35400801DI	53,80
0,80	3,0	2	39	1,20	6	KF35400802	40,60	KF35400802ZX	43,80	KF35400802DI	63,00
0,80	3,0	2	60	1,20	9	KF35400803	49,00	KF35400803ZX	53,20	KF35400803DI	76,80
0,90	3,0	2	39	1,35	6	KF35400901	40,60	KF35400901ZX	43,80	KF35400901DI	63,00
1,00	3,0	2	39	1,50	4	KF35401001	32,00	KF35401001ZX	35,40	KF35401001DI	53,80
1,00	3,0	2	39	1,50	6	KF35401002	32,00	KF35401002ZX	35,40	KF35401002DI	53,80
1,00	3,0	2	39	1,50	9	KF35401003	40,60	KF35401003ZX	43,80	KF35401003DI	63,00
1,00	3,0	2	60	1,50	12	KF35401004	49,00	KF35401004ZX	53,20	KF35401004DI	76,80
1,20	3,0	2	39	1,80	6	KF35401201	32,00	KF35401201ZX	35,40	KF35401201DI	53,80
1,20	3,0	2	39	1,80	9	KF35401202	40,60	KF35401202ZX	43,80	KF35401202DI	63,00
1,40	3,0	2	39	2,10	6	KF35401401	32,00	KF35401401ZX	35,40	KF35401401DI	53,80
1,40	3,0	2	39	2,10	9	KF35401402	40,60	KF35401402ZX	43,80	KF35401402DI	63,00
1,50	3,0	2	39	2,25	6	KF35401501	32,00	KF35401501ZX	35,40	KF35401501DI	53,80
1,50	3,0	2	39	2,25	9	KF35401502	40,60	KF35401502ZX	43,80	KF35401502DI	63,00
1,50	3,0	2	60	2,25	12	KF35401503	49,00	KF35401503ZX	53,20	KF35401503DI	76,80
1,80	3,0	2	39	2,70	9	KF35401801	40,60	KF35401801ZX	43,80	KF35401801DI	63,00
1,80	3,0	2	39	2,70	12	KF35401802	42,00	KF35401802ZX	45,40	KF35401802DI	64,40
2,00	3,0	2	39	3,00	9	KF35402001	40,60	KF35402001ZX	43,80	KF35402001DI	64,40
2,00	3,0	2	39	3,00	12	KF35402002	42,00	KF35402002ZX	45,40	KF35402002DI	64,40
2,00	3,0	2	60	3,00	15	KF35402003	49,00	KF35402003ZX	53,20	KF35402003DI	76,80
2,50	3,0	2	60	3,00	15	KF35402501	49,00	KF35402501ZX	53,20	KF35402501DI	76,80

## VHM-MICRO-RADIUSFRÄSER

## KFB350 (1,5xØ) / KFB351 (2-3xØ)



Einsatzgebiete: Universell einsetzbar, sowohl für den Dentalbereich, Kleinstformenbau, Uhren- und Schmuckindustrie sowie zum Fräsen von Elektroden.  
KFB350 = Extrakurze, stabile Ausführung.

application: Universal applications. Well suited for dental, jewelry and miniature mould making industry as well as for the machining of electrodes.  
KFB350 = extra short, stable construction.

### Hinweis/Einsatzempfehlung:

unbeschichtet K15F			ZX3-(TiAlN)-beschichtet			Diamant-beschichtet		
STAHL steel +1300Miner	Kunststoff plastic	ALU aluminium	STAHL steel +1300Miner	INOX stainless steel	Titan Inconel Hastelloy	Graphit graphite	ALU > 9% Si	GFK CFK
GUSS cast iron	NE non ferrous	Messing brass	HRc 56					



• ab Lager / ex stock • kurzfristig / on short notice • Lieferzeit ca. 1-2 Wochen / delivery time approx. 1-2 weeks

### VHM-Micro-Radiusfräser KFB350 1,5xØ

d1 0/-0,01	d2 h6	z	l1	l2	Artikel-Nr. unbeschichtet (uncoated)	Preis Euro / je unbeschichtet (uncoated)	Artikel-Nr. (code no.) ZX3	Preis Euro / je ZX3	Artikel-Nr. (code no.) Diamant	Preis Euro / je Diamant
0,10	3,0	2	39	0,10	KFB3500010	50,00		---		---
0,15	3,0	2	39	0,20	KFB3500015	43,40		---		---
0,20	3,0	2	39	0,30	KFB3500020	39,60		---		---
0,25	3,0	2	39	0,35	KFB3500025	36,00		---		---
0,30	3,0	2	39	0,45	KFB3500030	32,60	KFB3500030ZX	35,20	KFB3500030DI	61,00
0,40	3,0	2	39	0,60	KFB3500040	21,80	KFB3500040ZX	24,40	KFB3500040DI	46,80
0,50	3,0	2	39	0,75	KFB3500050	18,20	KFB3500050ZX	20,80	KFB3500050DI	46,80
0,60	3,0	2	39	0,90	KFB3500060	18,20	KFB3500060ZX	20,80	KFB3500060DI	46,80
0,70	3,0	2	39	1,05	KFB3500070	18,20	KFB3500070ZX	20,80	KFB3500070DI	46,80
0,80	3,0	2	39	1,20	KFB3500080	18,20	KFB3500080ZX	20,80	KFB3500080DI	46,80
0,90	3,0	2	39	1,35	KFB3500090	18,20	KFB3500090ZX	20,80	KFB3500090DI	46,80
1,00	3,0	2	39	1,50	KFB3500100	14,60	KFB3500100ZX	17,40	KFB3500100DI	46,80
1,20	3,0	2	39	1,80	KFB3500120	18,20	KFB3500120ZX	20,80	KFB3500120DI	46,80
1,50	3,0	2	39	2,25	KFB3500150	14,60	KFB3500150ZX	17,40	KFB3500150DI	46,80
2,00	3,0	2	39	3,00	KFB3500200	14,60	KFB3500200ZX	17,40	KFB3500200DI	56,20

### VHM-Micro-Radiusfräser KFB351 2-3xØ

d1 0/-0,01	d2 h6	z	l1	l2	Artikel-Nr. unbeschichtet (uncoated)	Preis Euro / je unbeschichtet (uncoated)	Artikel-Nr. (code no.) ZX3	Preis Euro / je ZX3	Artikel-Nr. (code no.) Diamant	Preis Euro / je Diamant
0,10	3,0	2	39	0,2	KFB3510010	50,00		---		---
0,15	3,0	2	39	0,3	KFB3510015	43,40		---		---
0,20	3,0	2	39	0,5	KFB3510020	39,60		---		---
0,25	3,0	2	39	0,5	KFB3510025	36,00		---		---
0,30	3,0	2	39	1,0	KFB3510030	32,60	KFB3510030ZX	35,20	KFB3510030DI	61,00
0,35	3,0	2	39	1,0	KFB3510035	28,80	KFB3510035ZX	31,60	KFB3510035DI	---
0,40	3,0	2	39	1,0	KFB3510040	21,80	KFB3510040ZX	24,40	KFB3510040DI	46,80
0,50	3,0	2	39	1,5	KFB3510050	18,20	KFB3510050ZX	20,80	KFB3510050DI	46,80
0,60	3,0	2	39	1,5	KFB3510060	18,20	KFB3510060ZX	20,80	KFB3510060DI	46,80
0,70	3,0	2	39	2,0	KFB3510070	18,20	KFB3510070ZX	20,80	KFB3510070DI	46,80
0,80	3,0	2	39	2,0	KFB3510080	18,20	KFB3510080ZX	20,80	KFB3510080DI	46,80
0,90	3,0	2	39	2,5	KFB3510090	18,20	KFB3510090ZX	20,80	KFB3510090DI	46,80
1,00	3,0	2	39	3,0	KFB3510100	14,60	KFB3510100ZX	17,40	KFB3510100DI	46,80
1,10	3,0	2	39	3,0	KFB3510110	18,20	KFB3510110ZX	20,80	KFB3510110DI	---
1,20	3,0	2	39	1,8	KFB3500120	18,20	KFB3500120ZX	20,80	KFB3500120DI	46,80
1,40	3,0	2	39	4,0	KFB3510140	18,20	KFB3510140ZX	20,80	KFB3510140DI	46,80
1,50	3,0	2	39	2,3	KFB3500150	14,60	KFB3500150ZX	17,40	KFB3500150DI	46,80
1,60	3,0	2	39	4,0	KFB3510160	18,20	KFB3510160ZX	20,80	KFB3510160DI	56,20
1,80	3,0	2	39	5,0	KFB3510180	18,20	KFB3510180ZX	20,80	KFB3510180DI	56,20
2,00	3,0	2	39	3,0	KFB3500200	14,60	KFB3500200ZX	17,40	KFB3500200DI	56,20
2,50	3,0	2	39	7,0	KFB3510250	18,20	KFB3512500ZX	20,80	KFB3510250DI	56,20
3,00	4,0	2	44	10,0	KFB3510300	19,80	KFB3510300ZX	22,00	KFB3510300DI	50,40

# VHM-MICRO-RADIUSFRÄSER

# KFB352 (Eingriffstiefe bis 15mm)



Einsatzgebiete: Universell einsetzbar, sowohl für den Dentalbereich, Kleinstformenbau, Uhren- und Schmuckindustrie sowie zum Fräsen von Elektroden. Mit freigestelltem Hals für besonders schwer zugängliche Stellen.

application: Universal applications. Well suited for dental, jewelry and miniature mould making industry as well as for the machining of electrodes.

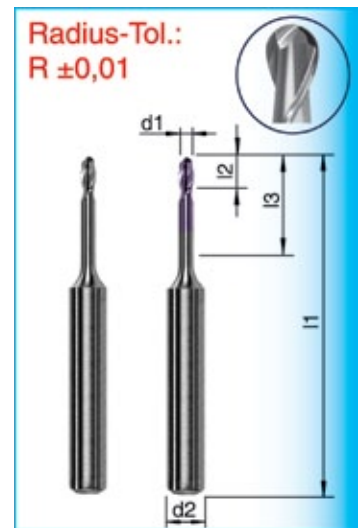

### Hinweis/Einsatzempfehlung:

unbeschichtet K15F			ZX3-(TiAlN)-beschichtet			Diamant-beschichtet		
STAHL steeel +1300N/mm²	Kunststoff plastic	ALU aluminium	STAHL steeel +1300N/mm²	INOX stainless steel	Titan Inconel Hastelloy	Graphit graphite	ALU > 9% Si	GFK CFK
GUSS cast iron	NE non ferrous	Messing brass	HRC 56					

• ab Lager / ex stock    • kurzfristig / on short notice    • Lieferzeit ca. 1-2 Wochen / delivery time approx. 1-2 weeks

d1 0/-0,01	d2 h6	z	l1	l2	l3	Artikel-Nr. unbeschichtet (uncoated)	Preis Euro / je unbeschichtet (uncoated)	Artikel-Nr. (code no.) ZX3	Preis Euro / je ZX3	Artikel-Nr. (code no.) Diamant	Preis Euro / je Diamant
0,40	3,0	2	39	0,60	2	KFB35200401	36,80	KFB35200401Z	40,20	KFB35200401D	62,80
0,50	3,0	2	39	0,75	2	KFB35200501	36,80	KFB35200501Z	40,20	KFB35200501D	62,80
0,50	3,0	2	39	0,75	4	KFB35200502	36,80	KFB35200502Z	40,20	KFB35200502D	62,80
0,50	3,0	2	60	0,75	6	KFB35200503	55,00	KFB35200503Z	58,80	KFB35200503D	88,40
0,60	3,0	2	39	0,90	4	KFB35200601	36,80	KFB35200601Z	40,20	KFB35200601D	62,80
0,80	3,0	2	39	1,20	4	KFB35200801	36,80	KFB35200801Z	40,20	KFB35200801D	62,80
0,80	3,0	2	39	1,20	6	KFB35200802	46,80	KFB35200802Z	49,80	KFB35200802D	74,20
0,80	3,0	2	60	1,20	9	KFB35200803	55,00	KFB35200803Z	58,80	KFB35200803D	88,40
1,00	3,0	2	39	1,50	4	KFB35201001	36,80	KFB35201001Z	40,20	KFB35201001D	62,80
1,00	3,0	2	39	1,50	6	KFB35201002	36,80	KFB35201002Z	40,20	KFB35201002D	62,80
1,00	3,0	2	39	1,50	9	KFB35201003	46,80	KFB35201003Z	49,80	KFB35201003D	74,20
1,00	3,0	2	60	1,50	12	KFB35201004	55,00	KFB35201004Z	58,80	KFB35201004D	88,40
1,20	3,0	2	39	1,80	6	KFB35201201	36,80	KFB35201201Z	40,20	KFB35201201D	62,80
1,50	3,0	2	39	2,25	6	KFB35201501	36,80	KFB35201501Z	40,20	KFB35201501D	62,80
1,50	3,0	2	39	2,25	9	KFB35201502	46,80	KFB35201502Z	49,80	KFB35201502D	74,20
1,50	3,0	2	60	2,25	12	KFB35201503	55,00	KFB35201503Z	58,80	KFB35201503D	88,40
2,00	3,0	2	39	3,00	9	KFB35202001	46,80	KFB35202001Z	49,80	KFB35202001D	74,20
2,00	3,0	2	39	3,00	12	KFB35202002	46,80	KFB35202002Z	49,80	KFB35202002D	74,20
2,00	3,0	2	60	3,00	15	KFB35202003	55,00	KFB35202003Z	58,80	KFB35202003D	88,40
2,50	3,0	2	60	3,75	15	KFB35202501	55,00	KFB35202501Z	58,80	KFB35202501D	88,40

## VHM-MICRO-1/4-KREIS KONKAVFRÄSER

## KF616



Einsatzgebiete: Micro-1/4-Kreis-Fräser aus Vollhartmetall. Der Radius (R) ist auf den kleinen Ø (d1) ausgerichtet und ermöglicht die präzise Bearbeitung komplexer Formen, kleinster Bohrungen und Nuten ab Ø 0,5mm.

application: CNC-micro-round-corner-cutters. Radius (R) is aligned with the small Ø (d1) which makes it possible to precisely machine complex forms and small slots starting at Ø 0.5mm.

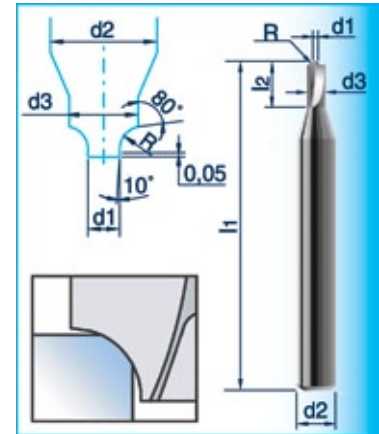

• ab Lager / ex stock • kurzfristig / on short notice • Lieferzeit auf Anfrage / delivery time upon request

Radius R ±0,02 mm	d1 ±0,10 mm	d2 h6 mm	d3 mm	l1 mm	l2 mm	Zähnezahl (no. of cutting edges)	Artikel-Nr. (code no.)	Preis Euro / je KF616
• 0,10	0,5	3,0	0,8	50	2,5	2	KF6160010	37,00
• 0,15	0,5	3,0	0,9	50	2,5	2	KF6160015	37,00
• 0,20	0,5	3,0	1,0	50	2,5	2	KF6160020	37,00
• 0,25	0,5	3,0	1,0	50	2,5	2	KF6160025	30,00
• 0,30	0,5	3,0	1,2	50	2,5	2	KF6160030	30,00
• 0,40	0,5	3,0	1,4	50	2,5	2	KF6160040	30,00
• 0,50	0,5	3,0	1,6	50	2,5	2	KF6160050	30,00
• 0,60	0,5	3,0	1,8	50	3,0	2	KF6160060	30,00
• 0,70	0,5	3,0	2,1	50	3,0	2	KF6160070	30,00
• 0,75	0,5	3,0	2,1	50	3,0	2	KF6160075	30,00
• 0,80	0,8	3,0	2,5	50	4,0	2	KF6160080	30,00
• 0,90	0,8	3,0	2,9	50	4,0	2	KF6160090	30,00
• 1,00	0,8	3,0	2,9	50	4,0	2	KF6160100	30,00
• 1,25	0,8	4,0	3,4	50	4,0	2	KF6160125	37,00
• 1,50	1,5	5,0	4,6	50	6,0	2	KF6160150	37,00
• 1,75	1,5	6,0	5,6	50	6,0	2	KF6160175	37,00
• 2,00	1,5	6,0	5,6	50	8,0	2	KF6160200	37,00
• 2,25	1,5	8,0	6,6	50	10,0	2	KF6160225	47,60
• 2,50	1,5	8,0	6,6	50	10,0	2	KF6160250	47,60
• 3,00	1,5	8,0	6,6	50	10,0	2	KF6160300	47,60
• 4,00	1,9	10,0	10,0	55	-	2	KF6160400	73,80
• 5,00	1,9	12,0	12,0	63	-	2	KF6160500	88,80

## Beschichtungsvarianten



Material	TIALN	TIALN	TIALN	TICN	DIAMANT
Mikrohärte (HV 0,05)	3000	3500	3300	3000	10000
Max. Anwendungs- Temperatur (°C)	800	800	800	400	700
Schichtfarbe	violett-grau	violett-grau	rot-violett	blau-grau	grau

## VHM-RADIUSFRÄSER 30°

## KFB... - ZX1



Einsatzgebiete: Universell einsetzbar, sowohl für hochfeste Werkstoffe als auch für Alu und NE-Metalle geeignet. Wahlweise unbeschichtet oder mit ZX1-Beschichtung.

application: Universal applications. Suitable for high hard materials as well as aluminium and nonferrous metals. Available uncoated or with ZX1-coating.

- KFB330 = 2 Schneiden mit Zentrumschnitt / 2 cutting edges, center cutting
- KFB362 = 3 Schneiden mit Zentrumschnitt / 3 cutting edges, center cutting
- KFB320 = 4 Schneiden mit Zentrumschnitt / 4 cutting edges, center cutting
- KFB382 = 2 Schneiden mit Zentrumschnitt EXTRA LANG / 2 cut. ed., center cutting EXTRA L.
- KFB383 = 3 Schneiden mit Zentrumschnitt EXTRA LANG / 3 cut. ed., center cutting EXTRA LONG
- KFB384 = 4 Schneiden mit Zentrumschnitt EXTRA LANG / 4 cut. ed., center cutting EXTRA LONG



• ab Lager / ex stock • kurzfristig / on short notice • Lieferzeit auf Anfrage / delivery time upon request

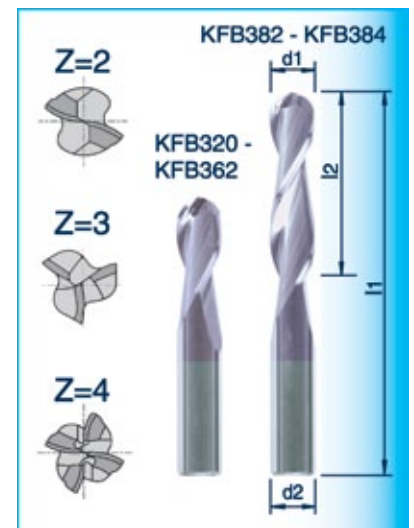

### VHM-Radiusfräser Werknorm

d1	d2	l2	l1	Artikel-Nr.	Artikel-Nr.	Artikel-Nr.	Preis	Artikel-Nr.	Artikel-Nr.	Artikel-Nr.	Preis	
h10	h6			2-Schneidig	3-Schneidig	4-Schneidig	Euro / je	2-Schneidig	3-Schneidig	4-Schneidig	Euro / je	
mm	mm	mm	mm	(code no.)	(code no.)	(code no.)	unbesch.	(code no.)	(code no.)	(code no.)	ZX1 - besch.	
Fräser unbeschichtet (uncoated)								Fräser ZX1 - beschichtet (ZX1 - coated)				
								2 cutting edges	3 cutting edges	4 cutting edges	ZX1 - coated	
•	1,0	3,0	3,0	38	KFB330010	KFB362010	KFB320010	10,60	KFB330010ZX1	KFB362010ZX1	KFB320010ZX1	12,60
•	1,5	3,0	4,5	38	KFB330015	KFB362015	KFB320015	10,00	KFB330015ZX1	KFB362015ZX1	KFB320015ZX1	11,80
•	2,0	3,0	6,3	38	KFB330020	KFB362020	KFB320020	10,00	KFB330020ZX1	KFB362020ZX1	KFB320020ZX1	11,80
•	2,5	3,0	9,5	38	KFB330025	KFB362025	KFB320025	9,60	KFB330025ZX1	KFB362025ZX1	KFB320025ZX1	11,40
•	3,0	3,0	12,0	38	KFB330030	KFB362030	KFB320030	9,00	KFB330030ZX1	KFB362030ZX1	KFB320030ZX1	10,60
•	4,0	4,0	14,0	50	KFB330040	KFB362040	KFB320040	13,00	KFB330040ZX1	KFB362040ZX1	KFB320040ZX1	15,20
•	5,0	5,0	16,0	50	KFB330050	KFB362050	KFB320050	14,40	KFB330050ZX1	KFB362050ZX1	KFB320050ZX1	17,80
•	6,0	6,0	19,0	50	KFB330060	KFB362060	KFB320060	14,80	KFB330060ZX1	KFB362060ZX1	KFB320060ZX1	18,20
•	7,0	7,0	20,0	60	KFB330070	KFB362070	KFB320070	20,40	KFB330070ZX1	KFB362070ZX1	KFB320070ZX1	25,60
•	8,0	8,0	20,0	63	KFB330080	KFB362080	KFB320080	20,60	KFB330080ZX1	KFB362080ZX1	KFB320080ZX1	26,40
•	9,0	9,0	22,0	63	KFB330090	KFB362090	KFB320090	28,00	KFB330090ZX1	KFB362090ZX1	KFB320090ZX1	33,40
•	10,0	10,0	22,0	70	KFB330100	KFB362100	KFB320100	33,60	KFB330100ZX1	KFB362100ZX1	KFB320100ZX1	41,00
•	12,0	12,0	25,0	76	KFB330120	KFB362120	KFB320120	39,80	KFB330120ZX1	KFB362120ZX1	KFB320120ZX1	47,40
•	14,0	14,0	32,0	89	KFB330140	KFB362140	KFB320140	70,20	KFB330140ZX1	KFB362140ZX1	KFB320140ZX1	81,00
•	16,0	16,0	38,0	89	KFB330160	KFB362160	KFB320160	76,00	KFB330160ZX1	KFB362160ZX1	KFB320160ZX1	89,60
•	18,0	18,0	38,0	101	KFB330180	KFB362180	KFB320180	124,80	KFB330180ZX1	KFB362180ZX1	KFB320180ZX1	138,60
•	20,0	20,0	38,0	101	KFB330200	KFB362200	KFB320200	143,60	KFB330200ZX1	KFB362200ZX1	KFB320200ZX1	159,40
•	25,0	25,0	38,0	101	KFB330250	KFB362250	KFB320250	179,40	KFB330250ZX1	KFB362250ZX1	KFB320250ZX1	200,20

### VHM-Radiusfräser EXTRA LANG

d1	d2	l2	l1	Artikel-Nr.	Artikel-Nr.	Artikel-Nr.	Preis	Artikel-Nr.	Artikel-Nr.	Artikel-Nr.	Preis	
h10	h6			2-Schneidig	3-Schneidig	4-Schneidig	Euro / je	2-Schneidig	3-Schneidig	4-Schneidig	Euro / je	
mm	mm	mm	mm	(code no.)	(code no.)	(code no.)	unbesch.	(code no.)	(code no.)	(code no.)	ZX1 - besch.	
Fräser unbeschichtet (uncoated)								Fräser ZX1 - beschichtet (ZX1 - coated)				
								2 cutting edges	3 cutting edges	4 cutting edges	ZX1 - coated	
•	3,0	3,0	25,0	76	KFB382030	KFB383030	KFB384030	18,20	KFB382030ZX1	KFB383030ZX1	KFB384030ZX1	20,80
•	4,0	4,0	28,0	76	KFB382040	KFB383040	KFB384040	20,80	KFB382040ZX1	KFB383040ZX1	KFB384040ZX1	24,00
•	5,0	5,0	32,0	76	KFB382050	KFB383050	KFB384050	24,40	KFB382050ZX1	KFB383050ZX1	KFB384050ZX1	28,60
•	6,0	6,0	38,0	76	KFB382060	KFB383060	KFB384060	25,60	KFB382060ZX1	KFB383060ZX1	KFB384060ZX1	29,80
•	8,0	8,0	40,0	101	KFB382080	KFB383080	KFB384080	33,20	KFB382080ZX1	KFB383080ZX1	KFB384080ZX1	40,60
•	10,0	10,0	50,0	101	KFB382100	KFB383100	KFB384100	52,00	KFB382100ZX1	KFB383100ZX1	KFB384100ZX1	61,60
•	12,0	12,0	50,0	101	KFB382120	KFB383120	KFB384120	56,20	KFB382120ZX1	KFB383120ZX1	KFB384120ZX1	66,40
•	16,0	16,0	64,0	127	KFB382160	KFB383160	KFB384160	124,20	KFB382160ZX1	KFB383160ZX1	KFB384160ZX1	144,80
•	20,0	20,0	76,0	152	KFB382200	KFB383200	KFB384200	258,40	KFB382200ZX1	KFB383200ZX1	KFB384200ZX1	283,00
•	25,0	25,0	76,0	152	KFB382250	KFB383250	KFB384250	303,40	KFB382250ZX1	KFB383250ZX1	KFB384250ZX1	331,20

## VHM-HSC-KOPIERFRÄSER 30°

## KFB502 / KFB503 - ZX3



Einsatzgebiete: Werkzeug und Hartmetall wurden speziell für die HSC- und Hartbearbeitung im Werkzeug- und Formenbau entwickelt. Hervorragend geeignet für die Trockenbearbeitung.

application: This tool and carbide grade were developed especially for high-speed and high-hard operations in tool making and die- and mould-making. Excellent suited for dry machining.

* Durchmesser-toleranz (Ø-tolerance) „e8“:				
Ø 1 - Ø 3	Ø 3 - Ø 6	Ø 6 - Ø 10	Ø 10 - Ø 18	Ø 18 - Ø 25
-0,014 / -0,028	-0,020 / -0,038	-0,025 / -0,047	-0,032 / -0,059	-0,040 / -0,073



KFB502 = kurze und lange Ausführung  
KFB503 = EXTRA LANGE Ausführung

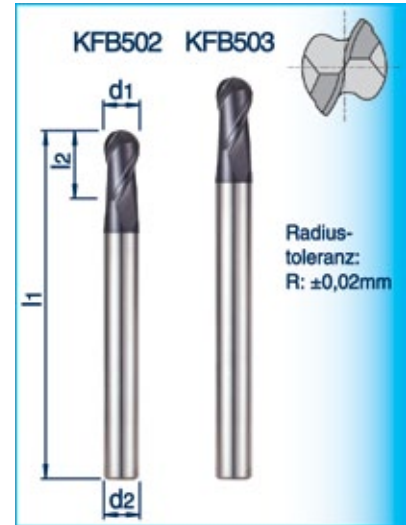

• ab Lager / ex stock • kurzfristig / on short notice • Lieferzeit auf Anfrage / delivery time upon request

### VHM-Kopierfräser KFB502 - kurze und lange Ausführung

	d1 e8* mm	d2 h6 mm	l2 mm	l1 mm	Zähnezahl (no. of cutting edges)	Artikel-Nr. (code no.)	Preis Euro / je KFB502 - ZX3
•	1,0	4,0	2,5	50	2	KFB502010ZX3	18,80
•	1,2	4,0	3,0	50	2	KFB502012ZX3	18,80
•	1,5	4,0	4,0	50	2	KFB502015ZX3	18,80
•	2,0	6,0	3,0	50	2	KFB502020ZXK	16,80
•	2,0	6,0	5,0	50	2	KFB502020ZX3	18,00
•	3,0	6,0	4,0	50	2	KFB502030ZXK	16,80
•	3,0	6,0	8,0	60	2	KFB502030ZX3	18,00
•	4,0	6,0	5,0	54	2	KFB502040ZXK	17,60
•	4,0	6,0	8,0	70	2	KFB502040ZX3	18,80
•	5,0	6,0	6,0	54	2	KFB502050ZXK	17,60
•	5,0	6,0	10,0	80	2	KFB502050ZX3	19,40
•	6,0	6,0	7,0	54	2	KFB502060ZXK	17,60
•	6,0	6,0	12,0	90	2	KFB502060ZX3	21,00
•	7,0	8,0	9,0	58	2	KFB502070ZXK	28,00
•	7,0	8,0	14,0	90	2	KFB502070ZX3	32,80
•	8,0	8,0	9,0	58	2	KFB502080ZXK	28,00
•	8,0	8,0	14,0	100	2	KFB502080ZX3	32,80
•	9,0	10,0	10,0	66	2	KFB502090ZXK	43,60
•	9,0	10,0	18,0	100	2	KFB502090ZX3	52,00
•	10,0	10,0	11,0	66	2	KFB502100ZXK	43,60
•	10,0	10,0	18,0	100	2	KFB502100ZX3	52,00
•	12,0	12,0	12,0	73	2	KFB502120ZXK	55,00
•	12,0	12,0	22,0	110	2	KFB502120ZX3	66,40
•	14,0	14,0	14,0	75	2	KFB502140ZXK	66,40
•	14,0	14,0	26,0	110	2	KFB502140ZX3	83,40
•	16,0	16,0	16,0	82	2	KFB502160ZXK	86,20
•	16,0	16,0	30,0	140	2	KFB502160ZX3	110,20
•	18,0	18,0	18,0	84	2	KFB502180ZXK	91,80
•	18,0	18,0	34,0	140	2	KFB502180ZX3	110,00
•	20,0	20,0	20,0	92	2	KFB502200ZXK	124,20
•	20,0	20,0	38,0	160	2	KFB502200ZX3	172,00
•	25,0	25,0	25,0	104	2	KFB502250ZXK	216,20
•	25,0	25,0	50,0	180	2	KFB502250ZX3	275,20

### VHM-Kopierfräser KFB503 - EXTRA LANGE Ausführung

	d1 e8* mm	d2 h6 mm	l2 mm	l1 mm	Zähnezahl (no. of cutting edges)	Artikel-Nr. (code no.)	Preis Euro / je KFB503 - ZX3
•	2,0	3,0	6,0	80	2	KFB503020ZX3	25,20
•	3,0	3,0	8,0	100	2	KFB503030ZX3	25,20
•	4,0	4,0	8,0	100	2	KFB503040ZX3	25,20
•	5,0	6,0	10,0	120	2	KFB503050ZX3	27,20
•	6,0	6,0	10,0	120	2	KFB503060ZX3	27,20
•	8,0	8,0	14,0	140	2	KFB503080ZX3	44,00
•	10,0	10,0	18,0	180	2	KFB503100ZX3	83,40
•	12,0	12,0	22,0	200	2	KFB503120ZX3	106,20
•	16,0	16,0	30,0	250	2	KFB503160ZX3	181,80
•	20,0	20,0	38,0	250	2	KFB503200ZX3	283,40

## VHM-HSC-KOPIERFRÄSER HRc55 bis HRc65

## KFB516 - ZX3



Einsatzgebiete: Werkzeug und Hartmetall wurden speziell für die HSC- und Hartbearbeitung im Werkzeug- und Formenbau entwickelt. Hervorragend geeignet für die Trockenbearbeitung.

application: This tool and carbide grade were developed especially for high-speed and high-hard operations in tool making and die- and mould-making. Excellent suited for dry machining.

\* Durchmessertoleranz (Ø-tolerance) „e8“:

Ø 1 - Ø 3	Ø 3 - Ø 6	Ø 6 - Ø 10	Ø 10 - Ø 18	Ø 18 - Ø 25
-0,014 / -0,028	-0,020 / -0,038	-0,025 / -0,047	-0,032 / -0,059	-0,040 / -0,073

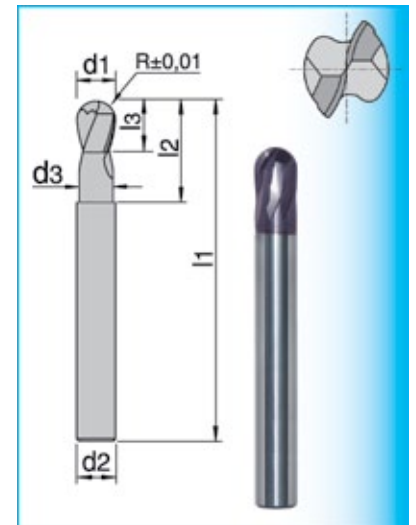

- ab Lager / ex stock
- kurzfristig / on short notice
- Lieferzeit auf Anfrage / delivery time upon request

	d1 e8 mm	d2 h6 mm	d3 mm	l3 mm	l2 mm	l1 mm	Zähnezahl (no. of cutting edges)	Artikel-Nr. (code no.)	Preis Euro / je KFB516 - ZX3
•	1,0	4	0,95	1,0	2,2	50	2	KFB516010ZX3	23,40
•	1,2	4	1,10	1,2	2,6	50	2	KFB516012ZX3	23,40
•	1,5	4	1,40	1,5	3,0	50	2	KFB516015ZX3	23,40
•	2,0	6	1,90	2,0	4,0	50	2	KFB516020ZX3	22,20
•	3,0	6	2,90	3,0	6,0	60	2	KFB516030ZX3	22,20
•	4,0	6	3,90	4,0	8,0	70	2	KFB516040ZX3	23,00
•	5,0	6	4,90	5,0	10,0	80	2	KFB516050ZX3	23,80
•	6,0	6	5,90	6,0	12,0	90	2	KFB516060ZX3	25,60
•	7,0	8	6,90	7,0	14,0	90	2	KFB516070ZX3	40,40
•	8,0	8	7,90	8,0	16,0	100	2	KFB516080ZX3	40,20
•	9,0	10	8,90	9,0	18,0	100	2	KFB516090ZX3	65,20
•	10,0	10	9,90	10,0	20,0	100	2	KFB516100ZX3	65,20
•	12,0	12	11,90	12,0	24,0	110	2	KFB516120ZX3	83,60
•	14,0	14	13,80	14,0	28,0	110	2	KFB516140ZX3	105,40
•	16,0	16	15,80	16,0	32,0	140	2	KFB516160ZX3	139,20
•	18,0	18	17,80	18,0	36,0	140	2	KFB516180ZX3	151,00
•	20,0	20	19,80	20,0	40,0	160	2	KFB516200ZX3	214,40
•	25,0	25	24,80	25,0	50,0	180	2	KFB516250ZX3	346,00

## VHM-HSC-KOPIERFRÄSER (zylindrisch abgesetzt) KFB506 - ZX3



Einsatzgebiete: Werkzeug und Hartmetall wurden speziell für die HSC- und Hartbearbeitung im Werkzeug- und Formenbau entwickelt. Hervorragend geeignet für die Trockenbearbeitung.

application: This tool and carbide grade were developed especially for high-speed and high-hard operations in tool making and die- and mould-making. Excellent suited for dry machining.

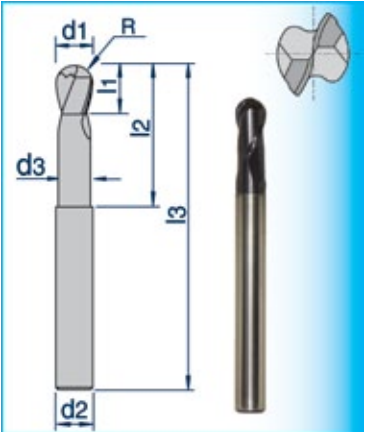

Ø-Toleranz für d1***:	
Ø 1 - Ø 6	Ø 6 - Ø 25
0 / -0,028	0 / -0,038

Radiustoleranz Typ KFB506:	
<math>< \text{Ø } 6,5</math>	> $\text{Ø } 6,5$
$\pm 0,01$	$\pm 0,02$

- ab Lager / ex stock
- kurzfristig / on short notice
- Lieferzeit auf Anfrage / delivery time upon request

d1 *** mm	R	d2 h6 mm	d3 mm	l1 mm	l2 mm	l3 mm	Artikel-Nr. (code no.)	Preis Euro / je KFB506 - ZX3
• 3,0	R1,5	6	-	8	-	70	KFB506030ZX3	22,40
• 4,0	R2,0	6	-	8	-	70	KFB506040ZX3	22,40
• 5,0	R2,5	6	-	12	-	80	KFB506050ZX3	23,40
• 6,0	R3,0	6	5,8	12	22	80	KFB506060ZX3	25,20
• 7,0	R3,5	8	-	14	-	90	KFB506070ZX3	39,20
• 8,0	R4,0	8	7,8	14	27	90	KFB506080ZX3	39,40
• 10,0	R5,0	10	9,8	18	31	100	KFB506100ZX3	64,00
• 12,0	R6,0	12	11,8	22	35	110	KFB506120ZX3	80,40
• 14,0	R7,0	12	-	26	-	120	KFB506140ZX3	89,40
• 16,0	R8,0	16	15,8	30	50	140	KFB506160ZX3	114,60
• 18,0	R9,0	16	-	34	-	140	KFB506180ZX3	124,00
• 20,0	R10,0	20	19,8	38	58	160	KFB506200ZX3	177,80
• 25,0	R12,5	25	24,8	55	75	180	KFB506250ZX3	297,00

## VHM-HSC-KOPIERFRÄSER 30°

## KFB504 - ZX3



Einsatzgebiete: Werkzeug und Hartmetall wurden speziell für die HSC- und Hartbearbeitung im Werkzeug- und Formenbau entwickelt. Hervorragend geeignet für die Trockenbearbeitung.

application: This tool and carbide grade were developed especially for high-speed and high-hard operations in tool making and die- and mould-making. Excellent suited for dry machining.

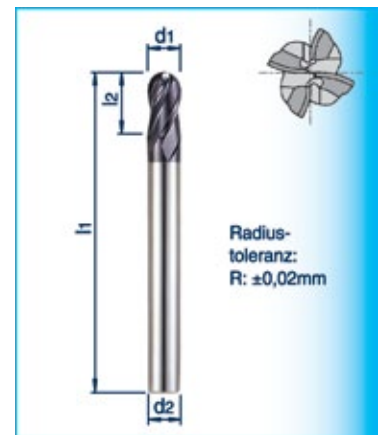

* Durchmessertoleranz (Ø-tolerance) „e8“:				
Ø 1 - Ø 3	Ø 3 - Ø 6	Ø 6 - Ø 10	Ø 10 - Ø 18	Ø 18 - Ø 25
-0,014 / -0,028	-0,020 / -0,038	-0,025 / -0,047	-0,032 / -0,059	-0,040 / -0,073



- ab Lager / ex stock
- kurzfristig / on short notice
- Lieferzeit auf Anfrage / delivery time upon request

d1 e8* mm	d2 h6 mm	l2 mm	l1 mm	Zähnezahl (no. of cutting edges)	Artikel-Nr. (code no.)	Preis Euro / je KFB504 - ZX3
• 1,0	4,0	2,5	50	4	KFB504010ZX3	25,60
• 1,5	4,0	4,0	50	4	KFB504015ZX3	25,60
• 2,0	6,0	5,0	50	4	KFB504020ZX3	24,40
• 3,0	6,0	8,0	60	4	KFB504030ZX3	24,40
• 4,0	6,0	8,0	70	4	KFB504040ZX3	25,20
• 5,0	6,0	10,0	80	4	KFB504050ZX3	26,00
• 6,0	6,0	12,0	90	4	KFB504060ZX3	27,60
• 7,0	8,0	14,0	90	4	KFB504070ZX3	40,60
• 8,0	8,0	14,0	100	4	KFB504080ZX3	40,60
• 9,0	10,0	18,0	100	4	KFB504090ZX3	62,40
• 10,0	10,0	18,0	100	4	KFB504100ZX3	62,40
• 12,0	12,0	22,0	110	4	KFB504120ZX3	78,60
• 14,0	14,0	26,0	110	4	KFB504140ZX3	97,20
• 16,0	16,0	30,0	140	4	KFB504160ZX3	128,80
• 18,0	18,0	34,0	140	4	KFB504180ZX3	150,60
• 20,0	20,0	38,0	160	4	KFB504200ZX3	214,40
• 25,0	25,0	50,0	180	4	KFB504250ZX3	343,20

## VHM-MICRO-KUGELFRÄSER

## KFB510 - ZX3



Einsatzgebiete: Für die 3D-Bearbeitung im Formenbau. Speziell für HSC, Hart- und Trockenbearbeitung optimiert. Eingriffstiefe bis 5xD.

application: Well suited for 3D-machining in die- and mould-making. Optimized for HSC, high-hard and dry machining. Working length up to 5xD.

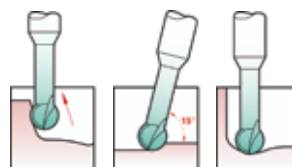
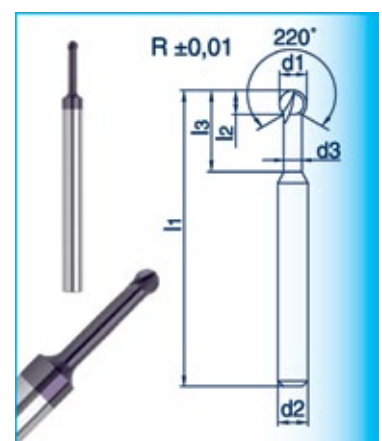

- ab Lager / ex stock
- kurzfristig / on short notice
- Lieferzeit auf Anfrage / delivery time upon request

d1 ±0,02 mm	d2 h6 mm	d3 mm	l1 mm	l2 mm	l3 mm	Artikel-Nr. (code no.)	Preis Euro / je KFB510 - ZX3
• 0,80	3,0	0,70	60	0,55	4,0	KFB5100080ZX	68,20
• 1,00	3,0	0,85	60	0,70	5,0	KFB5100100ZX	64,00
• 1,20	3,0	1,00	60	0,80	6,0	KFB5100120ZX	68,20
• 1,50	3,0	1,30	60	1,00	7,5	KFB5100150ZX	68,80
• 2,00	3,0	1,70	60	1,35	10,0	KFB5100200ZX	72,00
• 3,00	6,0	2,60	75	2,00	15,0	KFB5100300ZX	80,20
• 4,00	6,0	3,45	75	2,70	20,0	KFB5100400ZX	88,20
• 5,00	6,0	4,30	75	3,40	25,0	KFB5100500ZX	96,20

## VHM-HSC-KUGELFRÄSER

## KFB512 / KFB514



Einsatzgebiete: Werkzeug und Hartmetall wurden speziell für die HSC- und Hartbearbeitung im Werkzeug- und Formenbau entwickelt. Hervorragend geeignet für die Trockenbearbeitung.

application: This tool and carbide grade were developed especially for high-speed and high-hard operations in tool making and die- and mould-making. Excellent suited for dry machining.

\* Durchmesser-toleranz (Ø-tolerance) „h9“:

Ø 1 - Ø 3	Ø 3 - Ø 6	Ø 6 - Ø 10	Ø 10 - Ø 18	Ø 18 - Ø 25
0 / -0,025	0 / -0,030	0 / -0,036	0 / -0,043	0 / -0,052

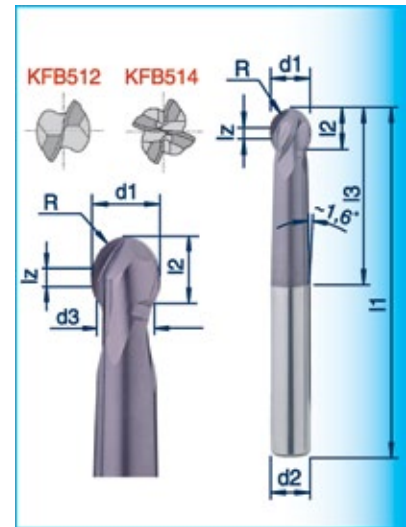

• ab Lager / ex stock • kurzfristig / on short notice • Lieferzeit auf Anfrage / delivery time upon request

### VHM-Kugelfräser KFB512 - 2-Schneidig

d1 h9 mm	Radius (R ±0,01)	d2 h6 mm	d3 mm	l2 mm	l3 mm	l1 mm	lz mm	Zähnezahl (no. of cutting edges)	Artikel-Nr. (code no.)	Preis Euro / je KFB512 - ZX3
• 3,0	1,5	6,0	2,5	4,0	30,0	80	1,5	2	KFB512030ZX3	28,40
• 4,0	2,0	6,0	3,3	5,0	30,0	80	1,5	2	KFB512040ZX3	28,80
• 5,0	2,5	6,0	4,1	6,0	43,0	80	2	2	KFB512050ZX3	28,40
• 6,0	3,0	6,0	4,7	7,0	30,0	100	2	2	KFB512060ZX3	32,00
• 8,0	4,0	8,0	6,5	9,0	36,0	100	3	2	KFB512080ZX3	47,40
• 10,0	5,0	10,0	8,2	11,0	43,0	100	3	2	KFB512100ZX3	78,60
• 12,0	6,0	12,0	9,8	13,0	52,0	100	3	2	KFB512120ZX3	97,20
• 16,0	8,0	16,0	13,4	15,0	61,0	150	3	2	KFB512160ZX3	174,80

### VHM-Kugelfräser KFB514 - 4-Schneidig

d1 h9 mm	Radius (R ±0,01)	d2 h6 mm	d3 mm	l2 mm	l3 mm	l1 mm	lz mm	Zähnezahl (no. of cutting edges)	Artikel-Nr. (code no.)	Preis Euro / je KFB514 - ZX3
• 5,0	2,5	6,0	4,1	6,0	43,0	80	2	4	KFB514050ZX3	28,40
• 6,0	3,0	6,0	4,7	7,0	30,0	100	2	4	KFB514060ZX3	32,00
• 8,0	4,0	8,0	6,5	9,0	36,0	100	3	4	KFB514080ZX3	47,40
• 10,0	5,0	10,0	8,2	11,0	43,0	100	3	4	KFB514100ZX3	78,60
• 12,0	6,0	12,0	9,8	13,0	52,0	100	3	4	KFB514120ZX3	97,20
• 16,0	8,0	16,0	13,4	15,0	61,0	150	3	4	KFB514160ZX3	174,80

## VHM-HSC-HARTFRÄSER

## KF600 / KF602 - ZX3



Einsatzgebiete: Werkzeug und Hartmetall wurden speziell für die HSC- und Hartbearbeitung im Werkzeug- und Formenbau entwickelt. Hervorragend geeignet für die Trockenbearbeitung.

application: This tool and carbide grade were developed especially for high-speed and high-hard operations in tool making and die- and mould-making. Excellent suited for dry machining.

KF600 = 6-8 Schneiden, lange Ausführung, Zylinderschaft DIN6535-HB (Weldon-Spannfläche)  
 KF602 = 6-8 Schneiden, Extra lange Ausführung, Zylinderschaft DIN6535-HB (Weldon-Spannfläche)  
 KF605 = 6-8 Schneiden, mit Eckenradius, Zylinderschaft DIN6535-HA



* Durchmessertoleranz (Ø-tolerance) „e8“:			
Ø 3 - Ø 6	Ø 6 - Ø 10	Ø 10 - Ø 18	Ø 18 - Ø 25
-0,020 / -0,038	-0,025 / -0,047	-0,032 / -0,059	-0,040 / -0,073

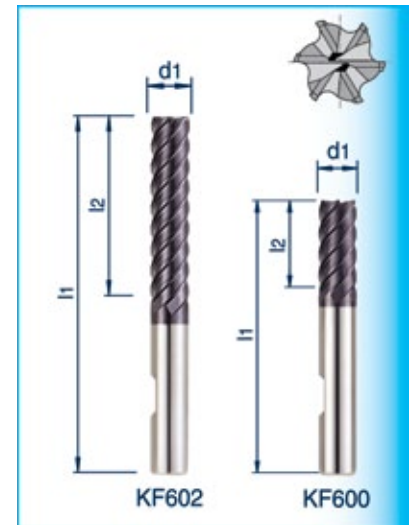

- ab Lager / ex stock
- kurzfristig / on short notice
- Lieferzeit auf Anfrage / delivery time upon request

### VHM-HSC-HARTFRÄSER

	d1 h10 mm	d2 h6 mm	l1 mm	l2 mm	Zähnezahl (no. of cutting edges)	Artikel-Nr. (code no.)	Preis Euro / je KF600/602 - ZX3
•	6,0	6,0	13	57	6	KF600060ZX3	22,00
•	6,0	6,0	26	70	6	KF602060ZX3	28,60
•	7,0	8,0	16	63	6	KF600070ZX3	28,00
•	8,0	8,0	19	63	6	KF600080ZX3	28,00
•	8,0	8,0	36	90	6	KF602080ZX3	37,60
•	9,0	10,0	19	72	6	KF600090ZX3	41,80
•	10,0	10,0	22	72	6	KF600100ZX3	41,80
•	10,0	10,0	46	100	6	KF602100ZX3	58,60
•	12,0	12,0	26	83	6	KF600120ZX3	56,60
•	12,0	12,0	56	110	6	KF602120ZX3	82,20
•	14,0	14,0	26	83	6	KF602140ZX3	71,00
•	16,0	16,0	32	92	6	KF600160ZX3	95,00
•	16,0	16,0	66	130	6	KF600160ZX3	142,60
•	18,0	18,0	32	92	8	KF600180ZX3	111,40
•	20,0	20,0	38	104	8	KF600200ZX3	139,80
•	20,0	20,0	76	140	6	KF602200ZX3	222,80
•	25,0	25,0	44	104	8	KF600250ZX3	246,40
•	25,0	25,0	92	180	6	KF602250ZX3	419,00

## VHM-SCHAFTFRÄSER MIT ECKENRADIUS

## KF506 - ZX3



Einsatzgebiete: Werkzeug und Hartmetall wurden speziell für die HSC- und Hartbearbeitung im Werkzeug- und Formenbau entwickelt. Hervorragend geeignet für die Trockenbearbeitung.

application: This tool and carbide grade were developed especially for high-speed and high-hard operations in tool making and die- and mould-making. Excellent suited for dry machining.

\* Durchmesser tolerance (Ø-tolerance) „e8“:

Ø 1 - Ø 3	Ø 3 - Ø 6	Ø 6 - Ø 10	Ø 10 - Ø 18	Ø 18 - Ø 25
-0,014 / -0,028	-0,020 / -0,038	-0,025 / -0,047	-0,032 / -0,059	-0,040 / -0,073

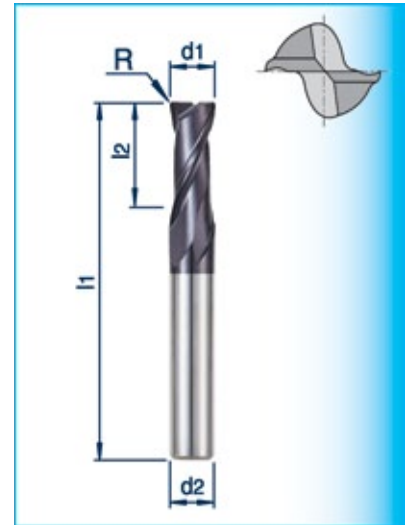

• ab Lager / ex stock • kurzfristig / on short notice • Lieferzeit auf Anfrage / delivery time upon request

	d1	d2	Eckenradius R	l2	l1	Zähnezahl	Artikel-Nr.	Preis
	e8	h6	(corner radius)			(no. of	(code no.)	Euro / je
	mm	mm	mm	mm	mm	cutting edges)		KF506 - ZX3
•	3,0	6,0	0,3	12	50	2	KF506030ZX31	25,00
•	4,0	6,0	0,3	15	50	2	KF506040ZX31	25,00
•	4,0	6,0	0,5	15	50	2	KF506040ZX32	25,00
•	5,0	6,0	0,3	20	60	2	KF506050ZX31	25,00
•	5,0	6,0	0,5	20	60	2	KF506050ZX32	25,00
•	6,0	6,0	0,5	20	60	2	KF506060ZX31	25,00
•	6,0	6,0	1,0	20	60	2	KF506060ZX32	25,00
•	8,0	8,0	0,5	25	70	2	KF506080ZX31	31,80
•	8,0	8,0	1,0	25	70	2	KF506080ZX32	31,80
•	8,0	8,0	1,5	25	70	2	KF506080ZX33	34,80
•	8,0	8,0	2,0	25	70	2	KF506080ZX34	34,80
•	10,0	10,0	0,5	30	90	2	KF506100ZX31	47,00
•	10,0	10,0	1,0	30	90	2	KF506100ZX32	47,00
•	10,0	10,0	1,5	30	90	2	KF506100ZX33	51,20
•	10,0	10,0	2,0	30	90	2	KF506100ZX34	51,20
•	12,0	12,0	0,5	30	90	2	KF506120ZX31	64,20
•	12,0	12,0	1,0	30	90	2	KF506120ZX32	64,20
•	12,0	12,0	1,5	30	90	2	KF506120ZX33	70,00
•	12,0	12,0	2,0	30	90	2	KF506120ZX34	70,00

## VHM-SCHAFTFRÄSER MIT ECKENRADIUS

## KF508 / KF509 - ZX3



Einsatzgebiete: Werkzeug und Hartmetall wurden speziell für die HSC- und Hartbearbeitung im Werkzeug- und Formenbau entwickelt. Hervorragend geeignet für die Trockenbearbeitung.

application: This tool and carbide grade were developed especially for high-speed and high-hard operations in tool making and die- and mould-making. Excellent suited for dry machining.

* Durchmesser-toleranz (Ø-tolerance) „e8“:				
Ø 1 - Ø 3	Ø 3 - Ø 6	Ø 6 - Ø 10	Ø 10 - Ø 18	Ø 18 - Ø 25
-0,014 / -0,028	-0,020 / -0,038	-0,025 / -0,047	-0,032 / -0,059	-0,040 / -0,073

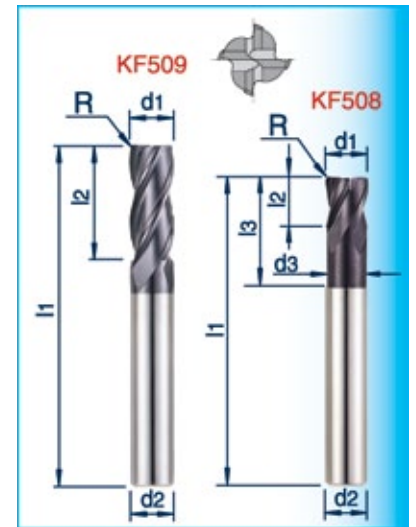

- ab Lager / ex stock
- kurzfristig / on short notice
- Lieferzeit auf Anfrage / delivery time upon request

### VHM-Schaftfräser mit Eckenradius - zylindrisch abgesetzt

	d1 e8 mm	d2 h6 mm	d3 h6 mm	Eckenradius R (corner radius) mm	l3 mm	l2 mm	l1 mm	Zähnezahl (no. of cutting edges)	Artikel-Nr. (code no.)	Preis Euro / je KF508 - ZX3
•	2,0	6,0	1,9	0,20	5,0	2,5	50	4	KF508020ZX3	20,80
•	2,5	6,0	2,4	0,25	6,0	3,0	50	4	KF508025ZX3	20,80
•	3,0	6,0	2,8	0,30	7,0	4,0	50	4	KF508030ZX3	20,80
•	3,5	6,0	3,2	0,35	8,0	4,5	50	4	KF508035ZX3	20,80
•	4,0	6,0	3,7	0,40	9,0	5,0	50	4	KF508040ZX3	20,80
•	5,0	6,0	4,6	0,50	12,0	6,0	50	4	KF508050ZX3	20,80
•	6,0	6,0	5,6	0,60	14,0	7,0	55	4	KF508060ZX3	20,80
•	8,0	8,0	7,4	0,80	18,0	10,0	60	4	KF508080ZX3	26,60
•	10,0	10,0	9,4	1,00	25,0	12,0	70	4	KF508100ZX3	39,20
•	12,0	12,0	11,4	1,20	30,0	15,0	80	4	KF508120ZX3	53,60
•	16,0	16,0	15,4	1,60	35,0	18,0	90	4	KF508160ZX3	97,00

### VHM-Schaftfräser mit Eckenradius

	d1 e8 mm	d2 h6 mm	Eckenradius R (corner radius) mm	l2 mm	l1 mm	Zähnezahl (no. of cutting edges)	Artikel-Nr. (code no.)	Preis Euro / je KF509 - ZX3
•	3,0	6,0	0,3	12	50	4	KF509030ZX31	27,40
•	4,0	6,0	0,3	15	50	4	KF509040ZX31	27,40
•	4,0	6,0	0,5	15	50	4	KF509040ZX32	27,40
•	5,0	6,0	0,3	20	60	4	KF509050ZX31	27,40
•	5,0	6,0	0,5	20	60	4	KF509050ZX32	27,40
•	6,0	6,0	0,5	20	60	4	KF509060ZX31	27,40
•	6,0	6,0	1,0	20	60	4	KF509060ZX32	27,40
•	8,0	8,0	0,5	25	70	4	KF509080ZX31	35,00
•	8,0	8,0	1,0	25	70	4	KF509080ZX32	35,00
•	8,0	8,0	1,5	25	70	4	KF509080ZX33	38,00
•	8,0	8,0	2,0	25	70	4	KF509080ZX34	38,00
•	10,0	10,0	0,5	30	90	4	KF509100ZX31	51,60
•	10,0	10,0	1,0	30	90	4	KF509100ZX32	51,60
•	10,0	10,0	1,5	30	90	4	KF509100ZX33	56,40
•	10,0	10,0	2,0	30	90	4	KF509100ZX34	56,40
•	12,0	12,0	0,5	30	90	4	KF509120ZX31	70,80
•	12,0	12,0	1,0	30	90	4	KF509120ZX32	70,80
•	12,0	12,0	1,5	30	90	4	KF509120ZX33	77,20
•	12,0	12,0	2,0	30	90	4	KF509120ZX34	77,20

## VHM-SCHAFTFRÄSER Kurze und Lange Ausführung

## KF502 - ZX3



Einsatzgebiete: Werkzeug und Hartmetall wurden speziell für die HSC- und Hartbearbeitung im Werkzeug- und Formenbau entwickelt. Hervorragend geeignet für die Trockenbearbeitung.

application: This tool and carbide grade were developed especially for high-speed and high-hard operations in tool making and die- and mould-making. Excellent suited for dry machining.

\* Durchmesser-toleranz (Ø-tolerance) „e8“:

Ø 1 - Ø 3	Ø 3 - Ø 6	Ø 6 - Ø 10	Ø 10 - Ø 18	Ø 18 - Ø 25
-0,014 / -0,028	-0,020 / -0,038	-0,025 / -0,047	-0,032 / -0,059	-0,040 / -0,073



Diese Schaftfräser sind in ähnlichen Baumaßen auch als 3-Schneider kurzfristig erhältlich.  
These end mills are also available with 3 cutting edges on short notice upon request.

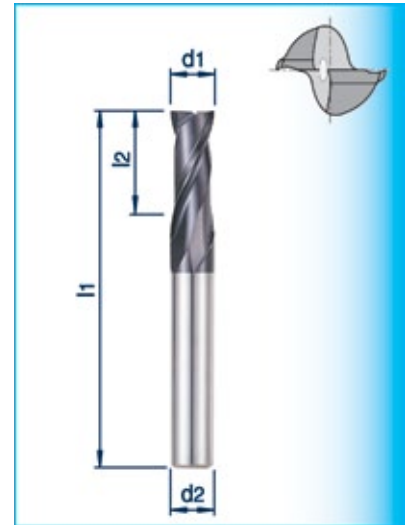

• ab Lager / ex stock • kurzfristig / on short notice • Lieferzeit auf Anfrage / delivery time upon request

d1 e8 mm	d2 h6 mm	l2 mm	l1 mm	Artikel-Nr. (code no.) K=Kurz L=Lang	Preis Euro / je ZX3	d1 h1 mm	d2 h6 mm	l2 mm	l1 mm	Artikel-Nr. (code no.) K=Kurz L=Lang	Preis Euro / je ZX3
• 1,0	4,0	2,5	40	KF502010ZX3K	14,40	• 10,0	10,0	22,0	70	KF502100ZX3K	35,60
• 1,5	4,0	4,0	40	KF502015ZX3K	14,40	• 10,0	10,0	30,0	90	KF502100ZX3L	42,60
• 2,0	4,0	6,0	40	KF502020ZX3K	13,00	• 10,5	12,0	22,0	75	KF502105ZX3K	48,80
• 2,0	4,0	8,0	40	KF502020ZX3L	15,80	• 11,0	12,0	22,0	75	KF502110ZX3K	48,80
• 2,5	4,0	8,0	40	KF502025ZX3K	13,00	• 11,5	12,0	22,0	75	KF502115ZX3K	48,80
• 3,0	6,0	8,0	45	KF502030ZX3K	19,00	• 12,0	12,0	26,0	75	KF502120ZX3K	48,80
• 3,0	6,0	12,0	50	KF502030ZX3L	22,60	• 12,0	12,0	30,0	90	KF502120ZX3L	58,60
• 3,5	6,0	10,0	45	KF502035ZX3K	19,00	• 13,0	12,0	26,0	85	KF502130ZX3K	61,80
• 4,0	6,0	11,0	45	KF502040ZX3K	19,00	• 14,0	14,0	26,0	85	KF502140ZX3K	61,80
• 4,0	6,0	15,0	50	KF502040ZX3L	22,60	• 14,0	16,0	40,0	110	KF502140ZX3L	83,40
• 4,5	6,0	11,0	45	KF502045ZX3K	19,00	• 15,0	16,0	26,0	90	KF502150ZX3K	80,80
• 5,0	6,0	13,0	50	KF502050ZX3K	19,00	• 16,0	16,0	32,0	100	KF502160ZX3K	80,80
• 5,0	6,0	20,0	60	KF502050ZX3L	22,60	• 16,0	16,0	50,0	110	KF502160ZX3L	109,20
• 5,5	6,0	13,0	50	KF502055ZX3K	19,00	• 17,0	16,0	32,0	100	KF502170ZX3K	107,20
• 6,0	6,0	13,0	50	KF502060ZX3K	19,00	• 18,0	18,0	32,0	100	KF502180ZX3K	107,20
• 6,0	6,0	20,0	60	KF502060ZX3L	22,60	• 18,0	20,0	50,0	110	KF502180ZX3L	148,00
• 6,5	8,0	16,0	60	KF502065ZX3K	24,20	• 19,0	20,0	32,0	100	KF502190ZX3K	134,00
• 7,0	8,0	16,0	60	KF502070ZX3K	24,20	• 20,0	20,0	38,0	105	KF502200ZX3K	134,00
• 7,5	8,0	16,0	60	KF502075ZX3K	24,20	• 20,0	20,0	55,0	110	KF502200ZX3L	180,60
• 8,0	8,0	19,0	60	KF502080ZX3K	24,20	• 22,0	20,0	38,0	105	KF502220ZX3K	174,00
• 8,0	8,0	25,0	70	KF502080ZX3L	28,80	• 24,0	25,0	45,0	120	KF502240ZX3K	214,00
• 8,5	10,0	19,0	70	KF502085ZX3K	35,60	• 25,0	25,0	45,0	120	KF502250ZX3K	214,00
• 9,0	10,0	19,0	70	KF502090ZX3K	35,60	• 25,0	25,0	75,0	140	KF502250ZX3L	288,80
• 9,5	10,0	19,0	70	KF502095ZX3K	35,60						

## VHM-SCHAFTFRÄSER Kurze und Lange Ausführung

## KF504 - ZX3



Einsatzgebiete: Werkzeug und Hartmetall wurden speziell für die HSC- und Hartbearbeitung im Werkzeug- und Formenbau entwickelt. Hervorragend geeignet für die Trockenbearbeitung.

application: This tool and carbide grade were developed especially for high-speed and high-hard operations in tool making and die- and mould-making. Excellent suited for dry machining.

\* Durchmesser tolerance (Ø-tolerance) „e8“:

Ø 1 - Ø 3	Ø 3 - Ø 6	Ø 6 - Ø 10	Ø 10 - Ø 18	Ø 18 - Ø 25
-0,014 / -0,028	-0,020 / -0,038	-0,025 / -0,047	-0,032 / -0,059	-0,040 / -0,073

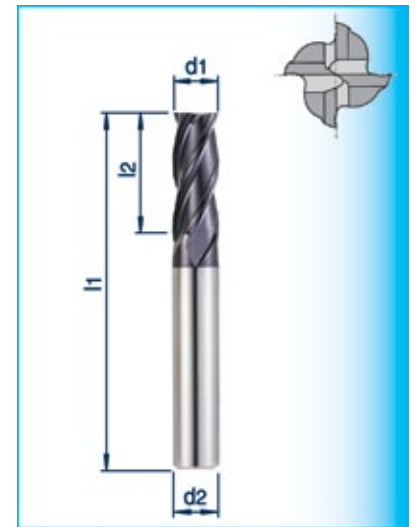

• ab Lager / ex stock • kurzfristig / on short notice • Lieferzeit auf Anfrage / delivery time upon request

d1 e8 mm	d2 h6 mm	l2 mm	l1 mm	Artikel-Nr. (code no.) K=Kurz L=Lang	Preis Euro / je ZX3	d1 h10 mm	d2 h6 mm	l2 mm	l1 mm	Artikel-Nr. (code no.) K=Kurz L=Lang	Preis Euro / je ZX3
• 2,0	4,0	6,0	40	KF504020ZX3K	13,00	• 10,0	10,0	30,0	90	KF504100ZX3L	42,60
• 2,0	4,0	8,0	40	KF504020ZX3L	15,80	• 10,5	12,0	22,0	75	KF504105ZX3K	48,80
• 2,5	4,0	8,0	40	KF504025ZX3K	13,00	• 11,0	12,0	22,0	75	KF504110ZX3K	48,80
• 3,0	6,0	8,0	45	KF504030ZX3K	19,00	• 11,5	12,0	22,0	75	KF504115ZX3K	48,80
• 3,0	6,0	12,0	50	KF504030ZX3L	22,60	• 12,0	12,0	26,0	75	KF504120ZX3K	48,80
• 3,5	6,0	10,0	45	KF504035ZX3K	19,00	• 12,0	12,0	30,0	90	KF504120ZX3L	58,60
• 4,0	6,0	11,0	45	KF504040ZX3K	19,00	• 13,0	12,0	26,0	85	KF504130ZX3K	61,80
• 4,0	6,0	15,0	50	KF504040ZX3L	22,60	• 14,0	14,0	26,0	85	KF504140ZX3K	61,80
• 4,5	6,0	11,0	45	KF504045ZX3K	19,00	• 14,0	16,0	40,0	110	KF504140ZX3L	83,40
• 5,0	6,0	13,0	50	KF504050ZX3K	19,00	• 15,0	16,0	26,0	90	KF504150ZX3K	80,80
• 5,0	6,0	20,0	60	KF504050ZX3L	22,60	• 16,0	16,0	32,0	100	KF504160ZX3K	80,80
• 5,5	6,0	13,0	50	KF504055ZX3K	19,00	• 16,0	16,0	50,0	110	KF504160ZX3L	109,20
• 6,0	6,0	13,0	50	KF504060ZX3K	19,00	• 17,0	16,0	32,0	100	KF504170ZX3K	107,20
• 6,0	6,0	20,0	60	KF504060ZX3L	22,60	• 18,0	18,0	32,0	100	KF504180ZX3K	107,20
• 6,5	8,0	16,0	60	KF504065ZX3K	24,20	• 18,0	20,0	50,0	110	KF504180ZX3L	148,00
• 7,0	8,0	16,0	60	KF504070ZX3K	24,20	• 19,0	20,0	32,0	100	KF504190ZX3K	134,00
• 7,5	8,0	16,0	60	KF504075ZX3K	24,20	• 20,0	20,0	38,0	105	KF504200ZX3K	134,00
• 8,0	8,0	19,0	60	KF504080ZX3K	24,20	• 20,0	20,0	55,0	110	KF504200ZX3L	180,60
• 8,0	8,0	25,0	70	KF504080ZX3L	28,80	• 22,0	20,0	38,0	105	KF504220ZX3K	174,00
• 8,5	10,0	19,0	70	KF504085ZX3K	35,60	• 24,0	25,0	45,0	120	KF504240ZX3K	214,00
• 9,0	10,0	19,0	70	KF504090ZX3K	35,60	• 25,0	25,0	45,0	120	KF504250ZX3K	214,00
• 9,5	10,0	19,0	70	KF504095ZX3K	35,60	• 25,0	25,0	75,0	140	KF504250ZX3L	288,80
• 10,0	10,0	22,0	70	KF504100ZX3K	35,60						

## Anfragebogen für VHM-Sonderfräser (questionnaire for special solid carbide end mills)

Bearbeitung von /  
mat. to be machined:

Stahl (steel)   
 GUß (cast iron)   
 AL (aluminum)   
 Graphit (graphite)

Werkstoffbezeichnung  
(material description):

.....

---

Schneidenanzahl/  
No. of flutes

2 Schneiden   
(2 flutes)  
 3 Schneiden   
(3 flutes)  
 4 Schneiden   
(4 flutes)  
 6 Schneiden   
(6 flutes)  
 sonstige  
(other)

---

übermitte Schneidend  
(center cutting)

---

Spiralwinkel  
helix angle

30°   
 45°   
 55°   
 60°   
 andere / other.....

---

Beschichtung /  
coating:

ZX3 (TiAlN)   
 ZX5 (TiN)   
 TiN   
 Diamant (diamond)   
 unbeschichtet /  
(uncoated)

---

andere / other.....

---

interne Kühlmittelzufuhr  
internal coolant IC:

mit K (with IC)   
 ohne K (without IC)

---

Anfrage (inquiry)   
 Bestellung (order)   
 Stückzahl (quantity):

---

Firma (company):  
 Straße (street):  
 Ort (town):  
 PLZ (zip code):  
 Land (country):  
 Ansprechpartner (contact):  
 e-mail:  
 Telefon (phone):  
 Telefax (fax):

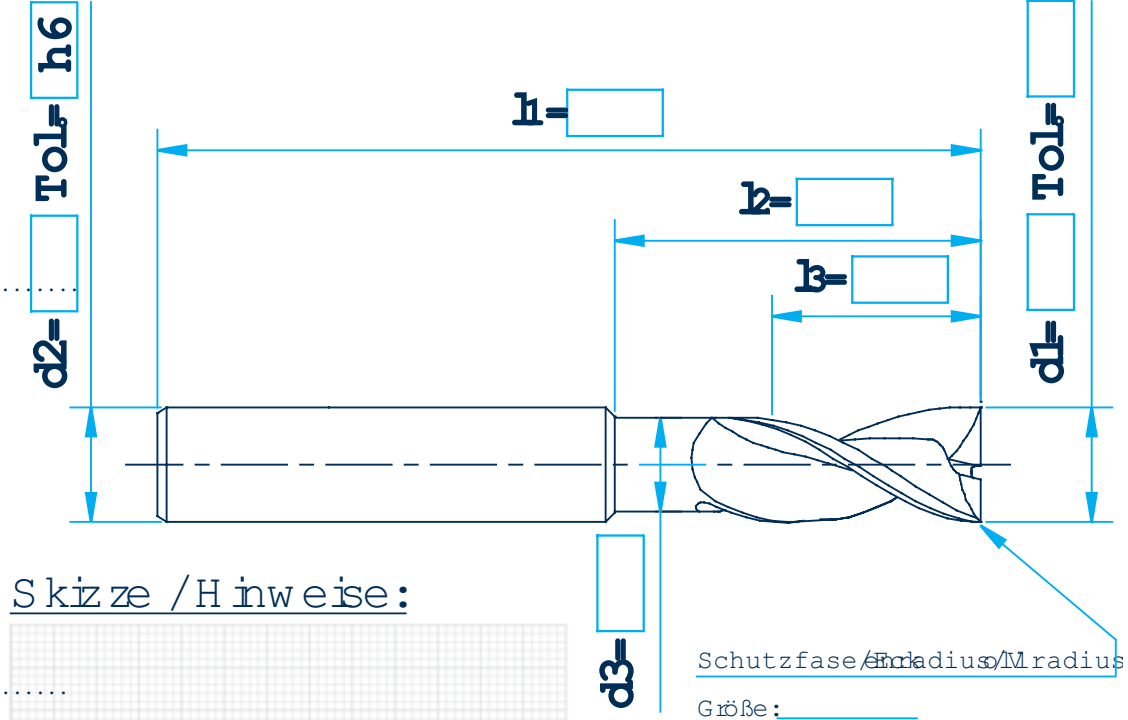

Schafformen DIN 6535 (shank type):

Form HA  Form HAK

Form HE  Form HEK

Form HB  Form HBK

## ENTGRATSPEZIALIST KEMPF

Entgraten Sie Ihre Bohrungen mit einzigartigen Entgratwerkzeuflösungen von Kempf. Wir bieten Ihnen im Bereich der Entgratwerkzeuge deutschlandweit die größte Auswahl und Vielfalt an standardisierten Problemlösern.

Ob wirtschaftliches Entgraten bei geringen Stückzahlen oder prozesssichere Bearbeitung in der Serienproduktion - Wir haben für jedes Entgratproblem die optimale Lösung!



Feinentgraten, Kantenverrunden und Oberflächenfinish mit High-Tech-Werkstoff



Entgraten an schwer zugänglichen Stellen und gewölbten Flächen ab  $\varnothing$  0,8mm

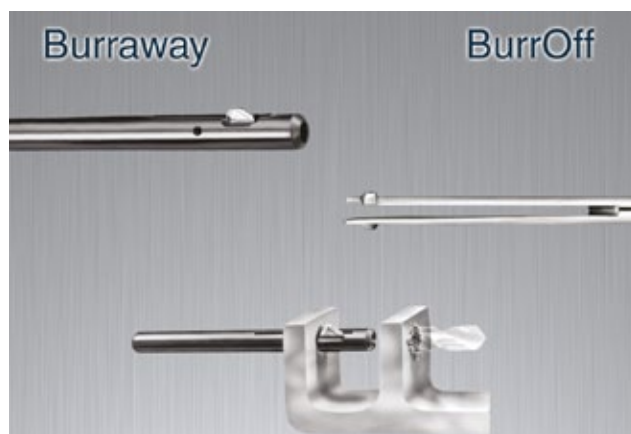

Wirtschaftliches Entgraten von Vorder- und Rückseite ab  $\varnothing$  0,8mm



Prozesssicheres High-Speed-Entgraten von Querbohrungen

## Produkt- und Kompetenzvielfalt

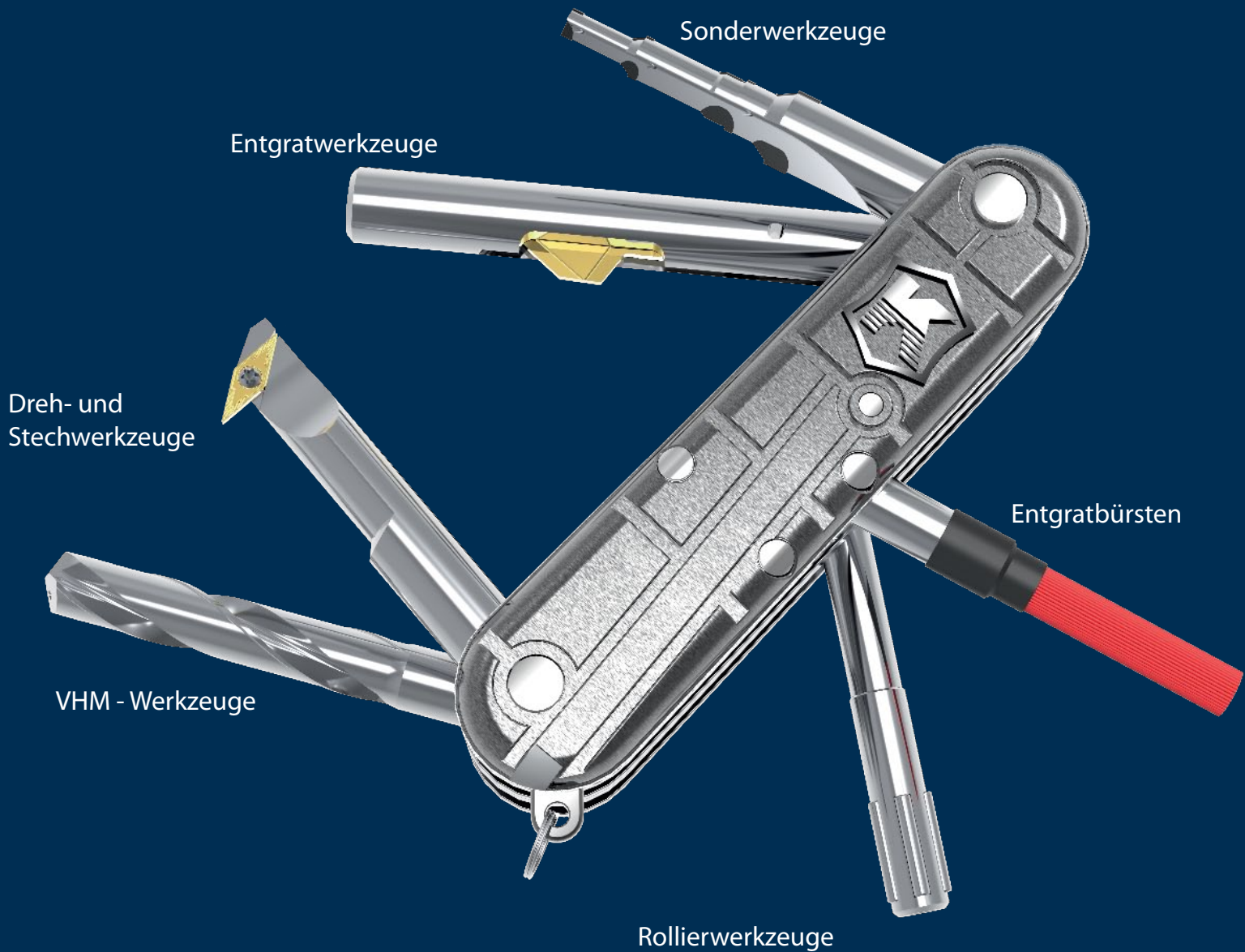

Vielfalt vereint

Unser Team freut sich auf Sie!

Kempf GmbH  
Sonderwerkzeuge in Präzision  
Leintelstraße 8  
73262 Reichenbach an der Fils

Tel: +49 (0) 71 53 95 49 0  
Fax: +49 (0) 71 53 95 49 49  
Email: [team@kempf-tools.de](mailto:team@kempf-tools.de)  
Web: [www.kempf-tools.de](http://www.kempf-tools.de)

