



MARINA ELECTRICAL EQUIPMENT, INC.

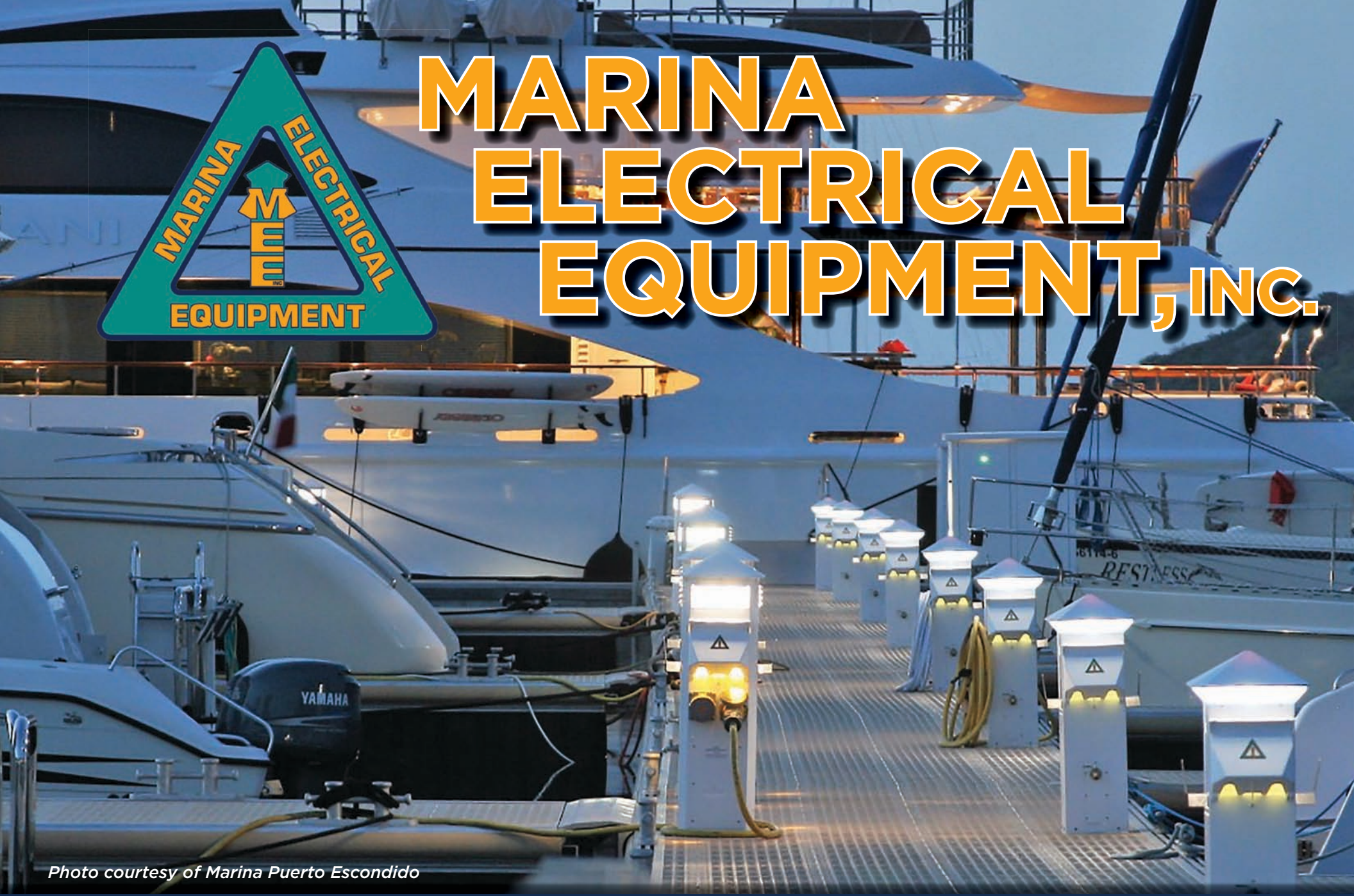

Photo courtesy of Marina Puerto Escondido

Marina Electrical Equipment, Inc.
1715 Merrimac Trail
Williamsburg, VA 23185

Toll Free: 1-855-258-3939
Fax: 1-757-258-3988
Email: info@marinaee.com
Web: www.marinaee.com

Business Hours:
Monday-Friday
8am-5pm EST

OUR OFFICE AND MANUFACTURING FACILITY

Located in Historic Williamsburg, Virginia, Marina Electrical Equipment, Inc. is a vertically integrated manufacturer, with all products proudly produced in our 147,000 square foot building. Please visit our website or contact us today to speak to our experienced sales and design team.

**1715 Merrimac Trail
Williamsburg, VA 23185
(855) 258-3939
(757) 258-3939
FAX (757) 258-3988
www.marinaee.com**

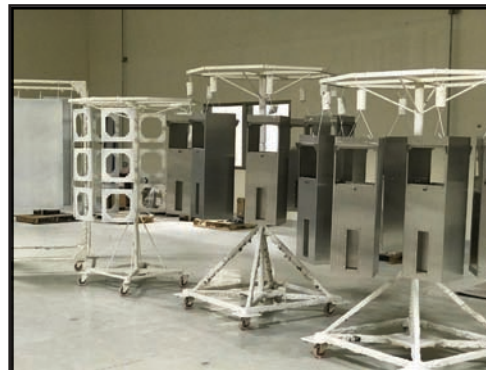
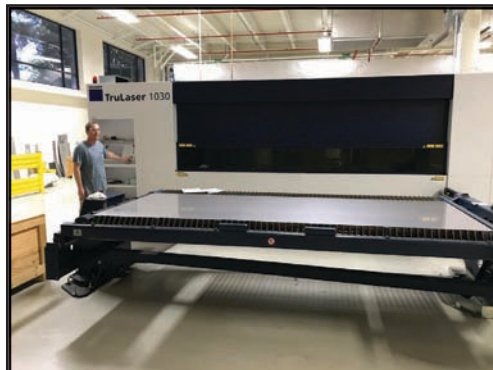

WHAT WE DO

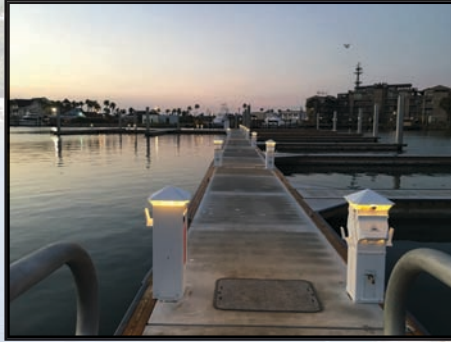

Marina Electrical Equipment manufactures the highest quality weatherproof electrical equipment in the marina industry.

Our 30 plus years of experience in this business allows us to produce the most advanced and user-friendly product selection of any power equipment manufacturer; to include: stainless steel and polycarbonate power pedestals, utility centers, fire safety pedestals, unit substations, panelboards, wire and cable, and solid state electric monitoring devices.

We also offer complimentary electrical layout and design consulting services by our experienced staff.

Marina Electrical Equipment is dedicated to continuing our long-standing history of designing and building the safest, most functional weatherproof electrical equipment in the business. We look forward to serving our customers and building lasting relationships in the process.



PRODUCT INDEX



HARBOR LIGHT SS
page 5



HARBOR LIGHT
page 6



COMMODORE SS
page 7



MARINA MATE SS
page 8



BAYSIDE
page 9



ANCHORAGE SS
page 10



FIRE STATION
page 11



**FIRE STATION
HOSE RACK**
page 12



**MARINA GROUND
FAULT CONTROL
PANEL**
page 13



**GTX™ UNIT
SUBSTATION**
page 14



**GTX™ SUPER YACHT
CENTER SUBSTATION**
page 15



**DISTRIBUTION
EQUIPMENT**
page 16



**INTERNATIONAL
INTELLIGENT
METERING**
page 17



**MARINA DESIGNS
AND LAYOUTS**
page 18



HARBOR LIGHT SS

Power Pedestal Model HLSS30100

Marina Electrical Equipment has performed extensive research and design to create the most innovative and user-friendly power pedestal, the "Harbor Light SS." This pedestal truly represents modernization and ease-of-use. We have taken all that we have learned over the past 30+ years in this business to create a power pedestal that is exceptionally durable, practical, and clean-looking, as well as simple to install and maintain.

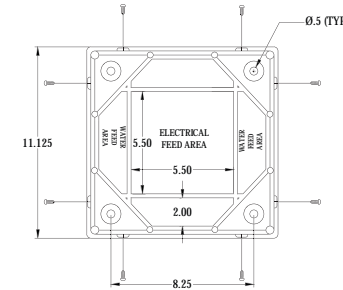

STANDARD DIMENSIONS: 42.5"H 11.125"W 11.125"D

STANDARD FEATURES

- Intertek-ETL Listed, tested in accordance with Underwriters Laboratories-231 standards, CAN/CSA Standard C22.2 No.29 and NFPA 303.
- Rugged, long-lasting 16-gauge 316L stainless steel NEMA 3RX main housing.
- Heavy-duty .1875" thick injection-molded polycarbonate top and lens assemblies.
- Limited 1-Year Warranty.
- Extra-wide back-lit receptacle faceplate for easier plug-in.
- Highest quality twist-lock receptacles and circuit breakers.
- Highest quality 100-Amp pin and sleeve receptacles (when 100-Amp receptacles are selected).
- Patented pivoting receptacle faceplate assembly, which simplifies field-maintenance tasks such as replacing circuit breakers, receptacles or meter current transformers.
- Photocell-controlled LED light fixture with fuse protection.
- 250-Amp rated copper stud-lug single phase 125/250V terminal block.
- Clean-looking, flush-mounted access panels.
- Newly designed, highly functional dual hose/cable brackets capable of holding min. 50' of standard 5/8" ID garden hose or 50' of 50-ampere, 4-wire shore power (S.O.) cord.
- Durable polycarbonate mounting base plate which isolates the bottom housing from the dock surface.
- Lockable polycarbonate weatherproof doors which shield the receptacles and circuit breakers from the elements while in use (as required by NFPA 303 and NEC Article 555).

OPTIONAL FEATURES

- Receptacle Options:
 - 20A, 125V Duplex GFCI.
 - 20A, 125V L5-20R Twist-Lock Shorepower.
 - 30A, 125V L5-30R Twist-Lock Shorepower.
 - 50A, 125V SS-1 Twist-Lock Shorepower.
 - 50A, 125/250V SS-2 Twist-Lock Shorepower.
 - 100A, 125/250V Pin and Sleeve Shorepower.
 - 100A, 125/250V Pin and Sleeve Shorepower.
 - 100A, 480V Pin and Sleeve Shorepower.
- Interlocking circuit breakers, ground fault circuit breakers.
- Solid-state electric monitoring for sub-metering kWh consumption.
- Wireless NUCORE™ remote meter reading.
- Ground Fault Monitoring at each slip (patented).
- 250-Amp rated copper stud-lug three phase 125/250V terminal block.
- 250-Amp rated split terminal block.
- 3/4" IPS ball valve hose bibs.
- Hose bib vacuum breakers.
- Water metering.
- Phone, Cable TV, and/or Data ports.
- Amber or Clear Polycarbonate Lens.



Harbor Light Mounting Detail



Protected kWh Counter



Extra-Wide Back-Lit Receptacle Faceplate



Easy-Access Terminal Block



Pivoting Faceplate Assembly

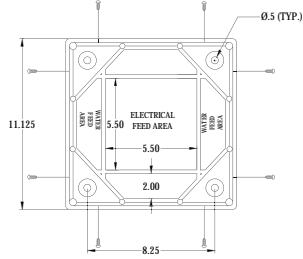

Harbor Light Mounting Detail



HARBOR LIGHT

Power Pedestal Model HL30100

The “Harbor Light” power pedestal has been developed as a polycarbonate sister to the “Harbor Light SS” and sets a new standard for durability and ease-of-use. Built to withstand the harshest environmental conditions, the “Harbor Light” keeps with the Marina Electrical Equipment philosophy of being incredibly simple to install, maintain, and operate for many years.



STANDARD DIMENSIONS: 42.5”H 11.125”W 11.125”D

STANDARD FEATURES

- Intertek-ETL Listed, tested in accordance with Underwriters Laboratories-231 standards, CAN/CSA Standard C22.2 No.29 and NFPA 303.
- Heavy-duty .1875” thick injection-molded polycarbonate NEMA 3RX main housing, lens and top assemblies.
- Limited 1-Year Warranty.
- Extra wide back-lit receptacle faceplate for easier plug-in.
- Highest quality twist-lock receptacles and circuit breakers.
- Patented pivoting receptacle faceplate assembly, which simplifies field-maintenance tasks such as replacing circuit breakers, receptacles or meter current transformer coils.
- Photocell-controlled LED light fixture with fuse protection.
- 250-Amp rated copper stud-lug single phase 125/250V terminal block.
- Newly designed, highly functional dual hose/cable brackets, capable of holding min. 50’ of standard 5/8” ID garden hose or 50’ of 50-ampere, 4-wire shore power (S.O.) cord.
- Clean-looking flush-mounted access panels.
- Durable polycarbonate mounting base plate which isolates the bottom housing from the dock surface.
- Lockable polycarbonate weatherproof doors which shield the receptacles and circuit breakers from the elements while in use (as required by NFPA 303 and NEC Article 555).

OPTIONAL FEATURES

- Receptacle Options:
 - 20A, 125V Duplex GFCI.
 - 20A, 125V L5-20R Twist-Lock Shorepower.
 - 30A, 125V L5-30R Twist-Lock Shorepower.
 - 50A, 125V SS-1 Twist-Lock Shorepower.
 - 50A, 125/250V SS-2 Twist-Lock Shorepower.
- Interlocking circuit breakers, ground fault circuit breakers.
- Solid-state electric monitoring for sub-metering kWh consumption.
- Wireless NUCORE™ remote meter reading.
- Ground Fault Monitoring at each slip (patented).
- 250-Amp rated copper stud-lug three phase 125/250V terminal block.
- 250-Amp rated split terminal block.
- 3/4” IPS ball valve hose bibs.
- Hose bib vacuum breakers.
- Water metering.
- Phone, Cable TV, and/or Data ports.
- Amber or Clear Polycarbonate Lens.



Protected KWH Counter



Extra-Wide Back-Lit Receptacle Faceplate



Easy-Access Terminal Block



Pivoting Faceplate Assembly

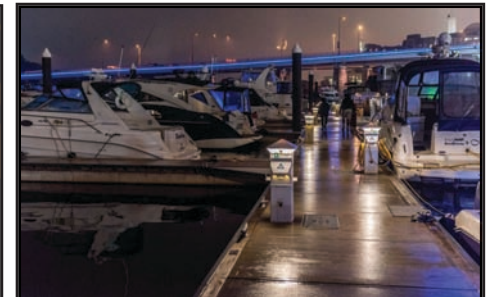



COMMODORE SS

Power Pedestal Models CD50200 & CD100200

Marina Electrical Equipment strives to stay on the cutting-edge of product development. Modern marinas require more electrical capability than ever before, and our flagship power pedestal, the "Commodore SS" is designed to fit that need. With the ability to supply dual voltages/phases at up to 500A each, the "Commodore SS" enables the marina to accommodate the diverse power requirements of the larger super-yachts.

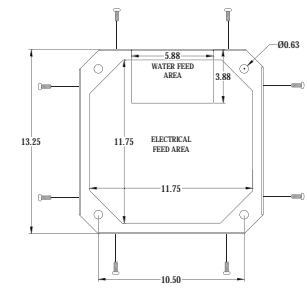

Commodore SS Single Feed Mounting Detail

STANDARD DIMENSIONS: 48"H 14"W 14"D

STANDARD FEATURES

- Intertek-ETL Listed, tested in accordance with Underwriters Laboratories-231 standards, CAN/CSA Standard C22.2 No.29 and NFPA 303.
- Rugged, long-lasting 16-gauge 316L stainless steel NEMA 3RX main housing.
- Heavy-duty .1875" thick injection-molded polycarbonate top assembly.
- Limited 1-Year Warranty.
- Extra wide back-lit receptacle faceplate for easier plug-in.
- Highest quality twist-lock receptacles and circuit breakers.
- Highest quality 100-Amp pin and sleeve receptacles (when 100-amp receptacles are selected).
- Industry-trusted 200-Amp pin and sleeve receptacles (when 200-amp receptacles are selected).
- Patented pivoting receptacle faceplate assembly, which simplifies field-maintenance tasks such as replacing circuit breakers, receptacles or meter current transformer coils.
- Two photocell-controlled LED light fixtures with fuse protection
- 250-Amp rated copper stud-lug single phase 125/250V terminal block.
- Newly designed, highly functional dual hose/cable brackets, capable of holding min. 50' of standard 5/8" ID garden hose or 50' of 50-ampere, 4-wire shore power (S.O.) cord.
- Clean-looking flush-mounted access panels.
- Lockable polycarbonate weatherproof doors which shield the receptacles and circuit breakers from the elements while in use (as required by NFPA 303 and NEC Article 555).

OPTIONAL FEATURES

- Receptacle Options:
 - 20A, 125V Duplex GFCI.
 - 20A, 125V L5-20R Twist-Lock Shorepower.
 - 30A, 125V L5-30R Twist-Lock Shorepower.
 - 50A, 125V SS-1 Twist-Lock Shorepower.
 - 50A, 125/250V SS-2 Twist-Lock Shorepower.
 - 100A, 125/250V Pin and Sleeve Shorepower.
 - 100A, 125/250Y Pin and Sleeve Shorepower.
 - 100A, 480V Pin and Sleeve Shorepower.
 - 200A, 480V Pin and Sleeve Shorepower.
- Hardwire Cam-Type Connectors.
- Interlocking circuit breakers, ground fault circuit breakers.
- Dual phase terminal blocks - available to 500-Amp ratings each.
- 250-Amp rated copper stud-lug three phase 125/250V terminal block(s).
- Solid-state electric monitoring for sub-metering kWh consumption.
- Wireless NUCORE™ remote meter reading.
- Ground Fault Monitoring at each slip (patented).
- 250-Amp rated copper stud-lug three phase 125/250V terminal block.
- 250-Amp rated split terminal block.
- 3/4" IPS ball valve hose bibs.
- Hose bib vacuum breakers.
- Water metering.
- Phone, Cable TV, and/or Data ports.
- Amber or Clear Polycarbonate Lens.

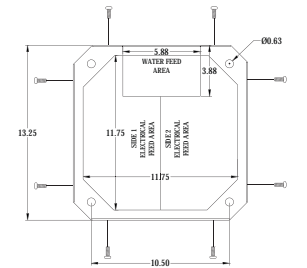

Commodore SS Dual Feed Mounting Detail



Easy-Access Terminal Block



Extra-Wide Back-Lit Receptacle Faceplate



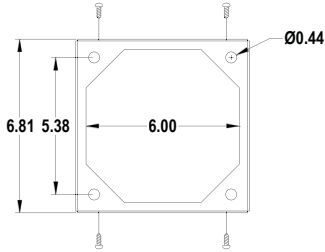

Marina Mate SS Single Feed Mounting Detail



Weatherproof Receptacle & Breaker Covers

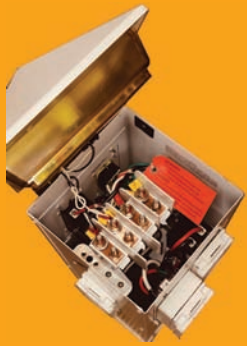

Easy-Access Terminal Block



Water Valves



MARINA MATE SS

Power Pedestal Model MMSS2050

The “Marina Mate SS” is a stylish and economical alternative to the full-sized “Harbor Light SS” power pedestal. This unit is the ideal choice for the smaller marina or personal docks with smaller power demands. It can be outfitted with receptacles and circuit breakers to serve as a full-fledged power pedestal, or simply act as an attractive luminaire to complement the marina or landscape ambience.



STANDARD DIMENSIONS: 30”H 8”W 8”D

STANDARD FEATURES

- Intertek-ETL Listed, tested in accordance with Underwriters Laboratories-231 standards, CAN/CSA Standard C22.2 No.29 and NFPA 303.
- Rugged, long-lasting 16-gauge 316L stainless steel NEMA 3RX main housing.
- Limited 1-Year Warranty.
- Highest quality twist-lock receptacles and circuit breakers.
- Patented pivoting faceplate assembly, which simplifies installation and field-maintenance tasks such as replacing circuit breakers, receptacles or meter current transformers.
- Photocell-controlled LED light fixture with fuse protection.
- 140-Amp rated copper stud-lug single phase 125/250V terminal block.
- Polycarbonate weatherproof covers.

OPTIONAL FEATURES

- Receptacle Options:
 - 20A, 125V Duplex GFCI.
 - 20A, 125V L5-20R Twist-Lock Shorepower.
 - 30A, 125V L5-30R Twist-Lock Shorepower.
 - 50A, 125V SS-1 Twist-Lock Shorepower.
 - 50A, 125/250V SS-2 Twist-Lock Shorepower.
- Ground fault circuit breakers.
- Solid-state electric monitoring for sub-metering kWh consumption.
- Wireless NUCORE™ remote meter reading.
- Ground Fault Monitoring at each slip (patented).
- 140-Amp rated copper stud-lug three phase 125/250Y terminal block.
- ¾” IPS ball valve hose bibs.
- Hose bib vacuum breakers.
- Phone, Cable TV, and/or Data ports.
- Amber or Clear Polycarbonate Lens.





BAYSIDE

Utility Center Model BU3050

The "Bayside" was developed as an economical solution for marinas and personal docks where space is limited. This compact utility center can handle a large current load, but is small enough to mount neatly on a triangular dock box or piling, keeping the deck surface clean and uncluttered. This attractive, little unit is packed full of features and electrical service capabilities without compromising quality or ease-of-use.

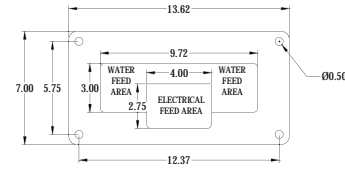

STANDARD DIMENSIONS: 14.5"H 11"W 10.625"D

STANDARD FEATURES

- Intertek-ETL Listed, tested in accordance with Underwriters Laboratories-231 standards, CAN/CSA Standard C22.2 No.29 and NFPA 303.
- Heavy-duty .1875" thick injection-molded polycarbonate NEMA 3RX main housing.
- Limited 1-Year Warranty.
- Extra wide receptacle faceplate for easier plug-in.
- Highest quality twist-lock receptacles and circuit breakers.
- Patented pivoting receptacle faceplate assembly, which simplifies field-maintenance tasks such as replacing circuit breakers, receptacles or meter current transformers.
- Photocell-controlled LED light fixture with fuse protection.
- 140-Amp rated copper stud-lug single phase 125/250V terminal block.
- Lockable polycarbonate weatherproof doors which shield the receptacles and circuit breakers from the elements while in use (as required by NFPA 303 and NEC Article 555).

OPTIONAL FEATURES

- Receptacle Options:
 - 20A, 125V Duplex GFCI.
 - 20A, 125V L5-20R Twist-Lock Shorepower.
 - 30A, 125V L5-30R Twist-Lock Shorepower.
 - 50A, 125V SS-1 Twist-Lock Shorepower.
 - 50A, 125/250V SS-2 Twist-Lock Shorepower.
- **V.I.P. Technology-Versatile Interchange Plates** for quick and easy receptacle configuration changes.
- Ground fault circuit breakers
- Solid-state electric monitoring for sub-metering kWh consumption.
- Wireless NUCORE™ remote meter reading.
- Ground Fault Monitoring at each slip (patented).
- 140-Amp rated copper stud-lug three phase 125/250Y terminal block.
- Phone, Cable TV, and/or Data ports
- Amber or Clear Polycarbonate Lens.
- 5052 aluminum pedestal.
- 316L stainless steel pedestal.
- 3/4" IPS ball valve hose bibs (with pedestal option).
- Hose bib vacuum breakers (with pedestal option).
- Water metering (with pedestal option).

Bayside Pedestal Mounting Detail



Easy-Access Terminal Block and Light Assembly



Weatherproof Receptacle & Breaker



Pivoting Faceplate Assembly

Bayside Mounted in Dock Box



Bayside Pedestal Option





Extra-Wide Receptacle Faceplate



Pivoting Faceplate Assembly



Easy-Access Terminals



ANCHORAGE SS

Power Outlet Panel Model AN3050

The "Anchorage SS" is a utilitarian-grade surface mount power outlet panel designed for commercial or industrial marinas and boatyards. The defining feature of this unit is its integral 100-Amp 120/240V ringless or ring-type utility meter socket for use with utility-style glass kWh meters.



STANDARD DIMENSIONS: 24.56"H 11.25"W 9.98"D

STANDARD FEATURES

- Intertek-ETL Listed, tested in accordance with Underwriters Laboratories-231 standards, CAN/CSA Standard C22.2 No.29 and NFPA 303.
- Rugged, long-lasting 16-gauge 316L stainless steel NEMA 3RX main housing.
- Limited 1-Year Warranty.
- Extra-wide receptacle faceplate for easier plug-in.
- Highest quality receptacles and circuit breakers.
- Patented pivoting faceplate assembly, which simplifies installation and field-maintenance tasks such as replacing circuit breakers and receptacles.
- 100-Amp rated 4-jaw ring-type or ringless-type utility meter socket & seal for glass-type kWh meter (single feed only - loop-feed not available).
- Lockable polycarbonate weatherproof door which shields the receptacles and circuit breakers from the elements while in use (as required by NFPA 303 and NEC Article 555).

OPTIONAL FEATURES

- Receptacle Options:
 - 20A, 125V Duplex GFCI.
 - * 20A, 125V L5-20R Twist-Lock Shorepower.
 - * 30A, 125V L5-30R Twist-Lock Shorepower.
 - * 50A, 125V SS-1 Twist-Lock Shorepower.
 - * 50A, 125/250V SS-2 Twist-Lock Shorepower.
- Interlocking circuit breakers, ground fault circuit breakers.

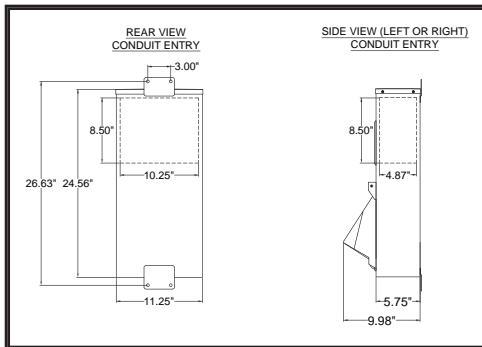

Anchorage SS Mounting & Cable Entry Details



Receptacles and breakers under lockable, weatherproof door



Stainless steel wall mounting brackets

Removable access covers for easy installation

Ring-type or ringless meter socket - 4, 5, and 7-JAW models available

316 stainless steel housing

Receptacles and circuit breakers under lockable, weatherproof, in-use door

OTHER STANDARD FEATURES:

Pivoting faceplate technology for easy maintenance



FIRE STATION

Safety Pedestal Model FS1020

Marina Electrical Equipment knows how important safety is to the marina manager and we have designed the “Fire Station” to fit this need. The “Fire Station” safety pedestal is the perfect solution to keep your marina in compliance with NFPA 303 6.2.1.1.1, which states: “(1) Extinguishers listed for Class A, Class B, and Class C fires shall be installed at the pier/land intersection on a pier that exceeds 25 ft. in length. (2) Additional fire extinguishers shall be placed such that the maximum travel distance to an extinguisher does not exceed 75 ft.” This pedestal compliments the look and feel of our other products and will stand ready for any marina emergency. This unit is also suitable for poolside or private dock environments as well.

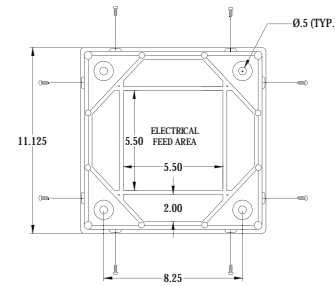

STANDARD DIMENSIONS: 42.5”H 11.125”W 11.125”D

STANDARD FEATURES

- Intertek-ETL Listed, tested in accordance with Underwriters Laboratories ANSI/UL 2017.
- Rugged, long-lasting 22-gauge 316L stainless steel NEMA 3RX main housing.
- Heavy-duty .1875” thick injection-molded polycarbonate top and lens assemblies.
- Limited 1-Year Warranty.
- Continuous-duty LED light fixture with fuse protection.
- 15-Amp rated single phase 125V terminal block.
- Unmistakable back-lit fire extinguisher symbol laser-cut in spring-loaded hinged cabinet door with red polycarbonate window.

OPTIONAL FEATURES

- 10-pound or 20-pound, Type ABC fire extinguisher, mounted on a bracket which suspends it above the bottom tray to inhibit corrosion.
- 24” life ring.
- Dual-function alarm and siren which activates with the removal of the optional 24” life ring and/or fire extinguisher.
- Amber or Clear Polycarbonate Lens.



Fire Station 10 or 20-lb. Extinguisher Option

Fire Station Mounting Detail





FIRE STATION HOSE RACK

Cabinet Model FSHR

Fire suppression systems are an integral part of the modern marina's fire safety design. These systems are vital, but often unsightly. Marina Electrical Equipment has designed the "Fire Station Hose Rack" to accommodate essential fire safety gear in one clean and functional cabinet. This design combines lighting, standpipe, valve/rack assembly with 100' of fire hose and one 10 or 20-lb Type ABC fire extinguisher in one compact package to stand ready for any fire emergency.



STANDARD DIMENSIONS: 43.75"H 34"W 10"D

STANDARD FEATURES

- Intertek-ETL Listed, tested in accordance with Underwriters Laboratories standard ANSI/UL 2017.
- Rugged, long-lasting 16-gauge 316L stainless steel main housing.
- Heavy-duty .1875" thick injection-molded polycarbonate lens assemblies.
- Limited 1-Year Warranty.
- Continuous-duty dual LED light fixture with fuse protection.
- 15-Amp rated single phase 125V terminal block.
- Unmistakable back-lit fire extinguisher symbol laser-cut in hinged cabinet door with red polycarbonate window.
- Laser-cut back-lit "F I R E" lettering on end walls with red polycarbonate window.
- Isolated mounting base which protects the bottom housing from the dock surface.

OPTIONAL FEATURES

- 10-pound or 20-pound, Type ABC fire extinguisher, mounted on a bracket which suspends it above the bottom tray to inhibit corrosion.
- 24" life ring
- Dual-function alarm and strobe which activates with the removal of the optional 24" life ring and/or fire extinguisher.
- Amber or Clear Polycarbonate Lens.

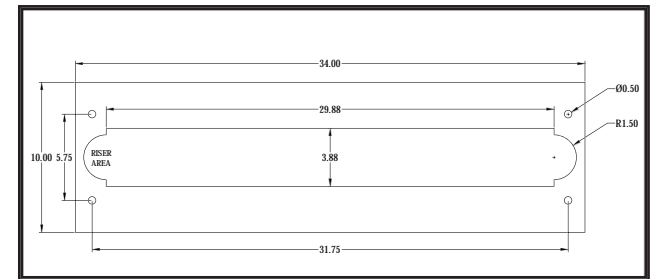

Fire Station Hose Rack
Mounting Detail





MARINA GROUND FAULT CONTROL PANEL

MEE GFCI control panels detect dangerous ground leakage currents in marina shore power electrical systems and fulfill the latest publication of NEC Article 555.3 entitled “Ground Fault-Protection.” All models are factory pre-set from 5mA to 5A based on customer and/or project requirements. All models feature rugged water-tight NEMA 4X rated nonmetallic enclosures, with test and reset buttons, and power and alarm LED pilot lights for unmistakable indication of a ground fault event.

FUNCTION

In a typical marina application, the secondary of the marina distribution transformer provides grounded 120/240 VAC or 208Y/120 VAC power to the power pedestals. When monitoring the main feeder, the Marina Ground Fault Control Panel will be connected to a Current Transformer (CT), which is placed around the NEUTRAL to GROUND main bonding jumper (if applicable) or all “HOT” conductors, plus the NEUTRAL conductor. NOTE: the GROUND conductor is not placed through the CT. This will allow the Marina Ground Fault Control Panel to detect all AC ground faults downstream of the CT, including any leakage current between the transformers and wiring to the power pedestals, and/or to any connected boat(s). Once the specified alarm leakage threshold has been detected, the device will illuminate the red LED pilot light and/or interrupt the circuit if connected to a shunt-trip circuit breaker.



STANDARD DIMENSIONS: 12.59”H 10.09”W 7.635”D

STANDARD FEATURES

- UL508A Listed.
- Satisfies NEC Article 555.3 entitled “Ground-Fault Protection”.
- Ground fault monitoring/circuit interrupting for marina shore power systems.
- Real-Time display of current leakage on system.
- Pre-set to alarm/trip values from 5mA to 5A current leakage to ground.
- Options available for single feeder monitoring and multiple-circuit branch monitoring .
- NEMA 4X rated, non-metallic lockable enclosure.
- NEMA 4X GREEN Power/System Safe LED pilot light on front.
- NEMA 4X RED Fault Alarm LED pilot light on front for indication of ground fault.
- NEMA 4X TEST/RESET pushbutton on front.
- Dry contact outputs for connection to 120VAC shunt-trip circuit breaker (for circuit interruption).

OPTIONAL FEATURES

- Single Channel, 120/240V, 208Y/120V or 220Y/127V (Main Feeder Monitoring/Interrupting)
- Single Channel, 480Y/277V or 480V Delta (Main Feeder Monitoring/Interrupting)
- Multiple Channel, 120/240V, 208Y/120V, 220Y/127V 480Y/277V or 480V (Branch Monitoring/Interrupting) - Requires individual CT per channel
- NEMA 4X Audible Alarm
- Factory wired/assembled within/to panelboards service disconnects and/or enclosed shunt-trip circuit breakers - consult factory for options

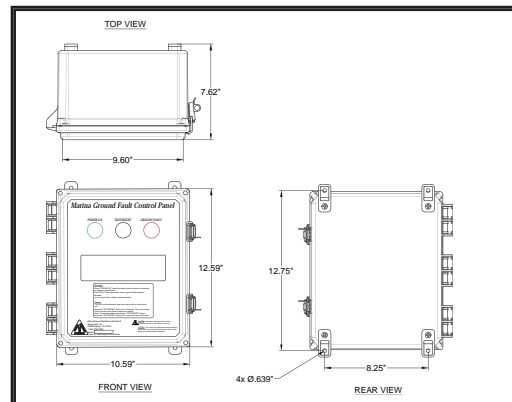

Marina Ground Fault Control Panel Detail





Integrated Panelboard



GTX™ UNIT SUBSTATION

Marina Electrical Equipment's "GTX™ Unit" Substations are designed and manufactured to maximize cable and installation cost savings through integration of a dry-type isolation transformer and factory-installed secondary panelboard. Constructed of the highest quality powder-coated 316L grade stainless steel, "GTX™ Unit" Substations are designed to withstand the harsh, corrosive environments found in marinas and boatyards.



STANDARD DIMENSIONS: 72”H 45”W 42/46”D

STANDARD FEATURES

- Intertek-ETL Listed, tested in accordance with Underwriters Laboratories-1062 standards, CAN/CSA Standard C22.2 No.31-10 and NFPA 303.
- Single Phase dry-type isolation transformers available to 330kVA.
- Three Phase dry-type isolation transformers available to 300kVA.
- (2) 2.5% FCAN and (2) 2.5% FCBN Primary Taps to compensate for varying incoming voltages.
- Transformer and secondary-side distribution panel mounted in single NEMA 3RX 316L stainless steel enclosure with single lockable access door (patent-pending).
- Integrated panelboard sizes up to 1200-ampere main circuit breaker/main lug.
- Extra-large wiring access area with removable .080” aluminium gland plate for simple cable entry/knockouts.
- Stainless steel hardware.
- 360-degree “Take-Apart” enclosure construction.
- Simple mounting and installation design:
 - Lifting: engineered lifting eyes designed/tested to lift four (4) times unit substation static weight (concealed beneath removable solar shield)
 - Handling/Positioning: front/side fork access.
 - Positioning: bottom rolling rails.
 - Mounting: 1/2” mounting slots at each corner (concealed behind removable access panels).
- Standard 12” base height, requiring no field-curbing or modifications to comply with 12” datum plane requirements.
- White textured powder-coated exterior finish.
- Thermostatically controlled axial fans maintain efficient operating temperature.
- Fine-stranded, tin-plated copper leads.
- Limited 1-Year Warranty.

OPTIONAL FEATURES

- Primary Voltages: 480V Single Phase, 480V Delta Three Phase, or 600V Delta Three Phase.
- Secondary Voltages: 120/240V Single Phase, 208Y/120V Three Phase, 220Y/127V Three-Phase.
- 50 Hz or 60 Hz Frequency.
- Primary Disconnect or Panelboard.
- Integrated Surge Protective Device (SPD) for supreme surge protection.
- Integrated Ground Fault Monitor Relay(s) (GFM) for maximum safety.
- Custom Configurations Available.
- Dual Phase Isolation Transformers.



Isolation Transformer & Panelboard



Concealed Lifting Eyes

Typical Panel and Transformer Combinations	
Single-Phase Panel Main	Transformer Size
200A	50 kVA
400A	100 kVA
700A	167 kVA
800A	200 kVA
1000A	250 kVA
1200A	330 kVA
Three-Phase Panel Main	Transformer Size
200A	75 kVA
300A	112.5 kVA
400A	150 kVA
600A	225 kVA
800A	300 kVA





GTX™ SUPER YACHT CENTER SUBSTATION

As the size of the mega and super-yachts increase, so do the power requirements. The “GTX™ Super Yacht Unit” Substation is the ideal solution for marinas looking to accommodate yachts of any size range and power requirements. Multiple voltages can be supplied from a single unit which reduce wiring and equipment costs, and provides the necessary versatility required by today’s mega and super-yachts.



STANDARD DIMENSIONS: 48”H 65”W 39”D

STANDARD FEATURES

- Intertek-ETL Listed, tested in accordance with Underwriters Laboratories-1062 standards, CAN/CSA Standard C22.2 No.31-10, NFPA 303 & Underwriters Laboratories-231 standards, CAN/CSA Standard C22.2 No.29.
- Rugged, long-lasting 14-gauge 316L stainless steel NEMA 3RX main housing.
- Limited 1-Year Warranty.
- Highest quality twist-lock receptacles.
- Highest quality 100-Amp pin and sleeve receptacles (when 100-Amp receptacles are selected).
- Industry-trusted 200-Amp pin and sleeve receptacles (when 200-Amp receptacles are selected).
- Rugged and versatile cam-lock hardwire single pole pin and sleeve devices (when selected).
- Time-tested, market-trusted circuit breakers and interior panelboards/bussing.
- “Take-Apart” construction offering 360 degree access with “drop-off” access panels.
- Four photocell-controlled LED light fixtures with fuse protection.
- Up to 800A, 480V 3-Phase primary terminal block.
- Clean-looking, flush-mounted access panels.
- Ultra-efficient dry-type isolation transformer(s) for single or multiple voltage outputs.

OPTIONAL FEATURES

- Receptacle Options:
 - 20A, 125V Duplex GFCI.
 - 20A, 125V L5-20R Twist-Lock Shorepower.
 - 30A, 125V L5-30R Twist-Lock Shorepower.
 - 50A, 125V SS-1 Twist-Lock Shorepower.
 - 50A, 125/250V SS-2 Twist-Lock Shorepower.
 - 100A, 125/250V Pin and Sleeve Shorepower.
 - 100A, 125/250Y Pin and Sleeve Shorepower.
 - 100A, 480V Pin and Sleeve Shorepower.
 - 200A, 480V Pin and Sleeve Shorepower.
- Hardwire Cam-Type Connectors (up to 690A at 480V) with electric safety interlock (first-make, last break).
- Interlocking circuit breakers, ground fault circuit breakers.
- Dual phase isolation transformers.
- Primary and secondary section interior panelboards.
- Solid-state electric monitoring for sub-metering kWh consumption.
- Wireless NUCORE™ remote meter reading.
- Ground Fault Monitoring at each slip (patented).
- ¾” IPS ball valve hose bibs.
- Hose bib vacuum breakers.
- Water metering.
- Phone, Cable TV, and/or Data ports.
- Amber or Clear Polycarbonate Lenses.



Front View



Primary Camlock Hardwire Access and Receptacles



Secondary Section Hardware Access and Receptacles



Panelboard Access for Primary and Secondary Side



Factory-Wired Panelboards

WIRE AND CABLE

- Types THWN and XHHW single conductor wire.
- Type W single and multi-conductor power cable.
- Types G and G-GC multi-conductor power cable.
- Many other types available.



Type THWN and XHHW Wire



Type W Portable Power Cable



Type G and Type G-GC Portable Power Cable



DISTRIBUTION EQUIPMENT

Panelboards, Transformers, Switchgear, Safety Switches, Wire and Cable.

Marina Electrical Equipment is committed to being an all-inclusive manufacturer and supplier of the highest quality marina electrical products in the industry. Our product scope does not stop at power pedestals alone, as we have the resources and the capability to produce or supply absolutely every piece of equipment necessary to satisfy your specific requirements and situation. Whether your project requires stand-alone transformers, panelboards, switchboards, service-entrance equipment and wire/cable, we can provide it all, tailored to your exact specifications at the most competitive prices.

PANELBOARDS

- Main Bus, 100-1200 Amp copper or aluminum.
- Integrated Surge Protective Device (SPD) for maximum surge protection.
- Integrated Ground Fault Monitor (GFM) for maximum safety.
- Main circuit breaker.
- Main lug only.
- Ground fault circuit breakers.
- Feed-through lugs.
- Branch-mounted main circuit breakers.
- Standard NEMA 3R surface-mount enclosures available.
- Stainless steel NEMA 3RX and NEMA 4X free-standing enclosures available.
- Stainless steel NEMA 3RX and NEMA 4X surface-mount enclosures available.
- UL/ETL, CSA Listed.



Panelboard Interior

TRANSFORMERS

- Copper or aluminum wound coils.
- Coils are double-dipped in high-temperature varnish and baked.
- Single phase transformers available from 50 kVA to 330 kVA.
- Three phase transformers available from 45 kVA to 500 kVA.
- Typical primary voltages: 480V, 480V Delta Three Phase, 600V Delta Three Phase.
- Typical secondary voltages: 120/240V Single Phase, 120/208V Wye Three Phase, 127/220V Wye Three Phase.
- Standard NEMA 3R enclosures available.
- Stainless steel NEMA 3RX and 4X enclosures available.
- UL and CSA Listed.
- Dual phase, single and three phase in one unit.

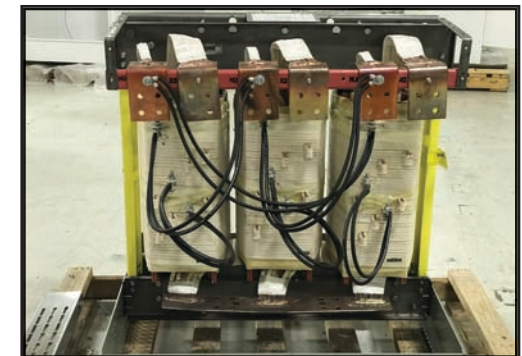

Dry Type Isolation Transformer

INTERNATIONAL INTELLIGENT METERING Solid State Electric Metering



Marina Electrical Equipment utilizes the latest in solid-state electric metering technology by International Intelligent Metering, LLC (IIM). The patented IIM sub-meter revolutionizes the utilities monitoring industry as it can be equipped with the wireless NuCore™ system which consists of an on-board transceiver device that communicates data to a central base station and PC at the marina office utilizing MESH Technology. This MESH configuration reduces issues with line of sight signal loss by using other neighboring meters to relay or “bounce” the signal to the central base station. Accumulated data is processed with the NuCore™ system software for creating customer profiles to manage usage history and billing and is based in Microsoft® Access and Excel format, making it compatible with any accounting management software for invoicing.

The IIM sub-meter has also made a giant leap in the industry with respect to safety. This unit is available with an optional patented on-board Ground Fault Monitoring Device, which detects current leakages at the slip. Ground faults are the leading causes of injuries, deaths, and equipment damages in marinas and boatyards, and the IIM Ground Fault Monitor option is a smart approach to improving marina safety.



Sentinel kWh Monitor

STANDARD FEATURES

- Intertek-ETL Listed, tested in accordance with Underwriters Laboratories-916 standards, CAN/CSA Standard C22.2 No.205.
- Approved by State of California Division of Measurement Standards.
- Exceeds ANSI C12.1 and ANSI C12.10.
- Kilowatt-Hour (kWH) consumption output. Optional 1 kWH or 1/10 kWH.
- Accuracy superior than $\pm 1\%$.
- Input Voltages:
 - Single-phase 120VAC, 120/240VAC, 60 Hz,
 - Three-phase 120/208VAC, 277/480VAC, 480VAC, 60 Hz.
- Input Current of 1-1,000 Amps.
- Input Protection:
 - Current-limiting flame proof resistor.
 - TVSS for surge protection.
 - Resettable PTC for overcurrent protection.
- Fully operational between -20°F (-30°C) to 140°F (60°C).
- Limited 1-Year Warranty.

OPTIONAL FEATURES

- Wireless KHZ Series NuCore™ system option for wireless meter reading and management.
- On-board ground fault monitoring KHG Series option can identify an individual boat with dangerous AC leakage to ground and/or water.
- KHZG Series to combine NuCore™ wireless meter reading and ground fault monitoring in one convenient package.

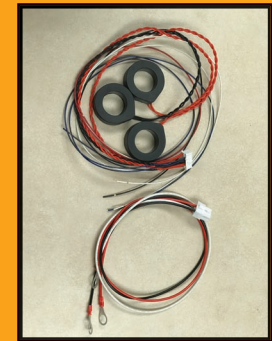

Power Connector and CT Harness

IIM NuCORE™ MESH TECHNOLOGY

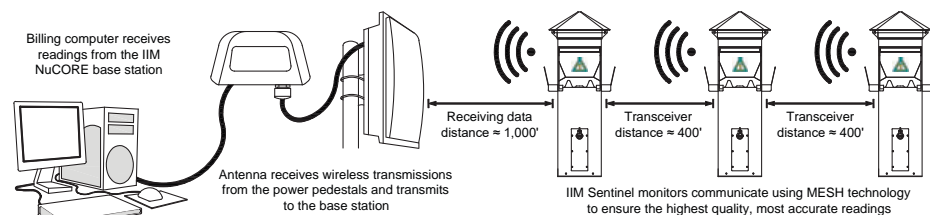

MARINA DESIGNS AND LAYOUTS

Complimentary Marina Electrical Designs and Layouts by Marina Electrical Equipment are just another aspect of our dedication to providing the highest quality customer service in the business. Our experienced technical staff can provide professional assistance in creating an economical electrical layout that keeps equipment, wire, and labor costs to a minimum - at no cost or obligation to you. There are no projects too large or too small for us to design and we welcome every opportunity to serve our customers.

All Complimentary Electrical Designs by Marina Electrical Equipment follow the most recent publication of the National Electric Code®, Article 555, Entitled: “Marinas and Boatyards” or the CSA Standards C22.1-12, Section 78, Entitled: “Marinas, Yacht Clubs, Marine Wharves, Structures, and Fishing Harbours”

STANDARD DETAILS OF OUR DESIGNS INCLUDE:

- Power Pedestal Type and Placement.
- Receptacle Sizes.
- Wire and Cable Gauge Sizes.
- Wire and Cable Types.
- Conduit Sizes.
- Substation Placement and Sizes.
- Panelboard Placement and Sizes.
- Transformer Placement and Sizes.
- Safety Switch Placement and Sizes.
- Load Calculations and Requirements.
- Voltage Drop Calculations.
- Electrical Layout Drawing.
- Electrical Single-Line Schematic Drawing.

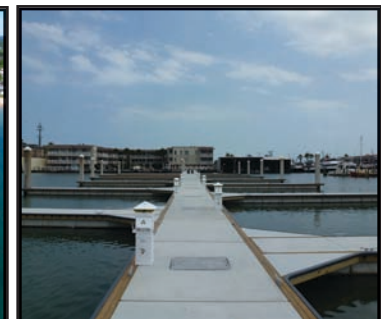
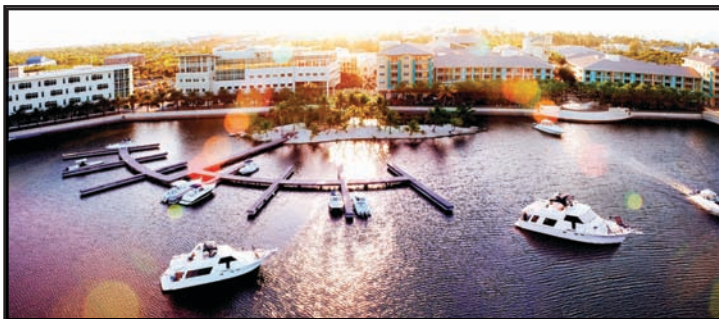
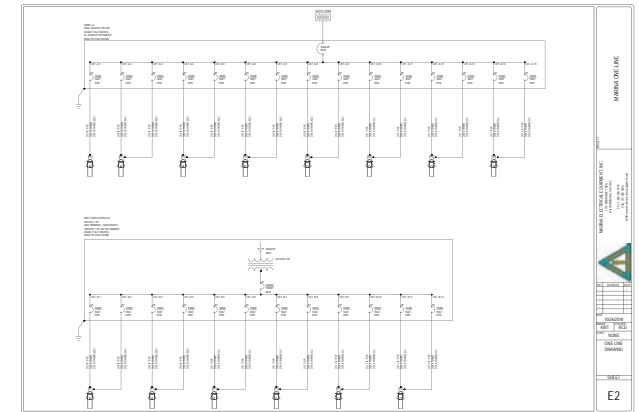
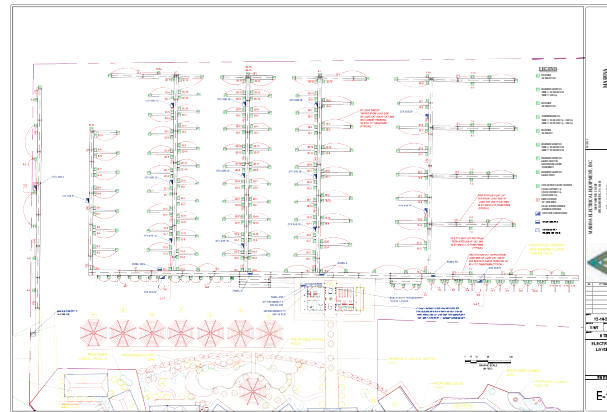



Photo courtesy of The Harborage Marina



@MEEWilliamsburg



Marina Electrical Equipment, Inc.



HIGHEST QUALITY WEATHERPROOF ELECTRICAL EQUIPMENT

Marina Electrical Equipment, Inc.
1715 Merrimac Trail
Williamsburg, VA 23185

Toll Free: 1-855-258-3939

Fax: 1-757-258-3988

Email: info@marinaee.com

Web: www.marinaee.com

