 - 代表和经销商:

 - Representative and Distributor:



DC SWISS SA

CH-2735 Malleray
Tel. +41 32 491 63 63
Fax +41 32 491 64 64
E-mail: info@dcswiss.ch



**THREADING
TECHNOLOGY**

www.dcswiss.com

DC SWISS SA
CN-EN-ID-2014



**THREADING
TECHNOLOGY**

www.dcswiss.com

产品目录
Main catalogue
CN-EN-ID-2014



**THREADING
TECHNOLOGY**



产品供应

ID 产品编号, 现货供应

* **ID** 产品编号, 现货供应, 售完即止

Availability of the articles

ID Identification number, available from stock

* **ID** Identification number, available from stock, while stock lasts

The management system of

DC Swiss SA

Grand rue 19 CP 363
2735 Malleray, Switzerland



has been assessed and certified as meeting the requirements of

ISO 9001:2008

For the following activities

**Cutting tool designer and manufacturer,
expert in Threading Technology.**

This certificate is valid from 7 September 2013 until 6 September 2016
and remains valid subject to satisfactory surveillance audits
Recertification audit due before 25 August 2016
Issue 4. Certified since September 2007

Authorized by

Two handwritten signatures in blue ink. The first signature appears to be 'S. Bieri' and the second is 'R. Weber'.



SGS Société Générale de Surveillance SA - Systems & Services Certification
Technoparkstrasse 1 8005 Zurich - Switzerland
T +41 (0)44 445-18-80 F +41 (0)44 445-10-88 www.sgs.com



Accreditation N° SCE9m 017

Page 1 of 1



K





 **VS**  **EL**
K613VS-3 **M**



 **TiCN**
K313TC-3
K413TC-3 **MF**



FPS-FAS



 **VS**  **EL**
FPS581VS-3 **M**
FPS681VS-3

 **VS**  **EL** 
FPS584VS-3 **M**
FPS684VS-3

 **VS**  **EL**
FAS581VS-3 **M**
FAS681VS-3

 **VS**  **EL** 
FAS584VS-3 **M**
FAS684VS-3

W





 **DL**
W320DL-4 **M**
W420DL-4

 **DL**
W360DL-3 **M**
W460DL-3 **G**
W460DL-5

FS





 **DL**  **E** **1.3 x P**
FS380DL-5 **M**

 **DL**  **C** **2.5 x P**
FS380DL-3 **M**

GW



 **VS**
GW3016 \leq **M12**
GW3016VS **MF**
 **VS** \leq **1/2 UNC**
 \leq **3/8 UNF**

GW3019
GW3019VS

AERO



SA320-4 **UNJF 3B**

N Schaublin



N1110-3 **SV**
N1210-3
N5120

NEW

编码说明 - CODIFICATION

DC 切削丝锥

DC Taps

样例 - Example



普通材料	Normal materials	N							
软质材料	Soft materials	W							
硬质材料	Tough materials	Z							
高抗拉强度材料	High tensile materials	H							
特殊合金	Special alloys	S							
特殊合金 (航空用)	Special alloys (Aero)	SA							
钛合金 (航空用)	Titanium alloys (Aero)	TL							
铸铁和铝铸件	Cast iron and aluminium casting	GG							
刚性攻丝	Rigid Tapping	RTS							
断屑槽	Swarf breaker	K							
MEGA 尺寸丝锥	MEGA tap sizes	MA							
特殊处理	Special execution		3						
DIN 标准 短型粗柄	DIN short - reinforced shank			1					
DIN 标准 短型细柄	DIN short - reduced shank			2					
DIN 标准 长型粗柄	DIN long - reinforced shank			3					
DIN 标准 长型细柄	DIN long - reduced shank			4					
DIN 标准 超长型粗柄	DIN extra-long - reinforced shank			5					
DIN 标准 超长型细柄	DIN extra-long - reduced shank			6					
DC 标准	DC standards			9					
ISO 标准 短型粗柄	ISO short - reinforced shank			11					
ISO 标准 短型细柄	ISO short - reduced shank			12					
直槽	Straight flutes			1					
直槽带刃倾角	Straight flutes with spiral point			2					
刃倾角	Spiral point			3					
< 27° 小角度左螺旋槽	< 27° left hand slow spiral flutes			4					
< 27° 小角度右螺旋槽	< 27° right hand slow spiral flutes			5					
> 27° 大角度右螺旋槽	> 27° right hand fast spiral flutes			6					
> 40° 大角度右螺旋槽	> 40° right hand fast spiral flutes			7					
10° 大角度右螺旋槽, 带刃倾角	10° right hand fast spiral flutes, spiral point			9					
标准	Standard					0			
跳齿	Interrupted thread					1			
背齿	Truncated thread					2			
内部冷却	Internal coolant					3			
跳齿, 内部冷却	Interrupted thread, internal coolant					4			
背齿, 内部冷却	Truncated thread, internal coolant					5			
"V" 表面处理	"V" surface treatment						V		
耐磨涂层	Wear-protective coating						VS		
氮化钛涂层 (TiN)	Titanium-nitride coating (TiN)						TN		
氮碳化钛涂层 (TiCN)	Titanium carbonitride coating (TiCN)						TC		
离子氮化 + "V" 表面处理	Plasma nitriding + "V" surface treatment						NV		
DLC 涂层	DLC-coating						DL		
Hardlube 涂层	Hardlube-coating						HL		
头攻丝锥	Taper tap								-1
二攻丝锥	Second tap								-2
末攻丝锥 / 2 - 3 螺距倒角	Bottoming tap / 2 - 3 chamfered threads								-3
3.5 - 5 螺距倒角, 带刃倾角	3.5 - 5 chamfered threads, spiral point								-4
1.5 - 2 螺距倒角	1.5 - 2 chamfered threads								-5
6 - 8 螺距倒角	6 - 8 chamfered threads								-8
螺纹丝锥组套	Thread taps set								-S

编码说明 - CODIFICATION

DC 挤压丝锥











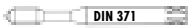

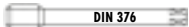







DC Thread formers

样例 - Example



< Ø 3 毫米 标准多边形	Standard polygon form < Ø 3 mm	FS							
≥ Ø 3 毫米 无凸角多边形	Passive polygon form ≥ Ø 3 mm	FPS							
≥ Ø 3 毫米 带凸角多边形	Active polygon form ≥ Ø 3 mm	FAS							
特殊处理	Special execution		3						
DIN 长型粗柄	DIN long - reinforced shank		3						
DIN 长型细柄	DIN long - reduced shank		4						
DIN 超长型粗柄	DIN extra-long - reinforced shank		5						
DIN 超长型细柄	DIN extra-long - reduced shank		6						
挤压丝锥	Thread former			8					
不带润滑槽	Without lubrication grooves				0				
带润滑槽	With lubrication grooves				1				
径向出水内部冷却	Internal coolant with radial outflow				4				
耐磨涂层	Wear-protective coating							VS	
氮化铬涂层 (CrN)	Chromenitride coating (CrN)							CN	
DLC 涂层	DLC-coating							DL	
2 - 3 螺距倒角	2 - 3 chamfered threads								-3
1.5 - 2 螺距倒角	1.5 - 2 chamfered threads								-5

图标说明 - PICTOGRAPHS

	DIN 371 规格 细柄 Reduced shank as per DIN 371		挤压丝锥 Thread former
	DIN 376 规格 细柄 Reinforce shank as per DIN 376		带润滑槽挤压丝锥 Thread former with lubrication grooves
	含钴高速钢 HSSE		头攻丝锥 Taper tap
	粉末高速钢 HSSE-PM		二攻丝锥 Second tap
	排屑槽数目 Number of flutes (Z)		末攻丝锥 Bottoming tap
	直槽 Straight flutes		手用丝锥, 两件套装 Hand taps, set of 2 pieces
	直槽带刃倾角 Straight flutes with spiral point		手用丝锥, 三件套装 Hand taps, set of 3 pieces
	只带刃倾角 Spiral point only		平衡导向 Parallel pilot
	40° 右螺旋槽 40° right hand spiral flutes		中心内部冷却 Internal coolant with frontal outflow
	背齿 Truncated thread		径向出水内部冷却 Internal coolant with radial outflow
	跳齿 Interrupted thread		

图标说明 - PICTOGRAPHS



使用 **DC** 应用图表查看材料分组
For material groups as per **DC** application chart

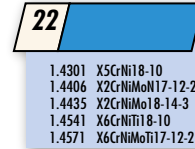
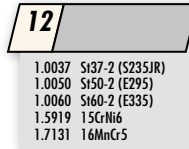

超长
Extra-long



通孔, 长切屑材料
Through hole, long chipping materials



通孔 < 1.5 x D, 短切屑材料
Through hole < 1.5 x D, short chipping materials



盲孔 < 1.5 x D, 长切屑材料
Blind hole < 1.5 x D, long chipping materials



盲孔 < 2.5 x D, 短切屑材料
Blind hole < 2.5 x D, short chipping materials



通孔 / 盲孔 < 2.5 x D
Through / blind hole < 2.5 x D



盲孔 < 3 x D
Blind hole < 3 x D



MEGA 螺纹攻丝头
MEGA thread tapping head



王冠形丝锥
Crown tap



钻攻一体丝锥
Combination drill/tap



底孔直径
Core hole diameter



外部直径的弧形边
Radius on external diameter



锥度螺纹 1:16 (NPT - NPTF - Rc)
Tapered thread 1:16 (NPT - NPTF - Rc)



EG 螺丝
Thread EG



左旋螺纹
Left hand thread



3.5 - 5 螺距倒角, B 类型
3.5 - 5 chamfered threads, form B



2 - 3 螺距倒角, C 类型
2 - 3 chamfered threads, form C



1.5 - 2 螺距倒角, E 类型
1.5 - 2 chamfered threads, form E



ISO 2 标准 公差等级 6H
Tolerance class ISO 2 6H



ISO 2 标准 公差等级 6H + 0.1 毫米
Tolerance class ISO 2 6H + 0.1 mm



ISO 3 标准 公差等级 6G
Tolerance class ISO 3 6G



DC "V" 表面处理
DC "V" surface treatment



DC 耐磨涂层
DC wear-protective coating



氮化钛涂层
Titanium-nitride coating



氮碳化钛涂层
Titanium-carbonitride coating



离子氮化 + "V" 表面处理
Plasma nitriding + "V" surface treatment



氮化铬涂层 (CrN)
Chromenitride coating



DLC 涂层
DLC-coating



Hardlube 涂层
Hardlube-coating



切屑碎片
Swarf fragments / constant chips



传统攻丝
For Classic Tapping



刚性攻丝
For Rigid Tapping

应用分组

APPLICATION GROUPS

应用分组样例

Examples for application groups

11 易切钢 1.0711 9520 1.0715 95Mn28 1.0718 95MnPh28 1.0726 35S20 1.0737 95MnPh36	12 结构钢， 渗碳钢 1.0037 Si37-2 (S235JR) 1.0050 Si50-2 (E295) 1.0060 Si60-2 (E335) 1.5919 15CrNi6 1.7131 16MnCr5	13 碳钢 1.0503 C45 1.0535 C55 1.0601 C60 1.1545 C10SW1 1.2067 102Cr6 (100Cr6)	14 合金钢 < 850 N/mm ² 1.2363 X100CrMoV5-1 1.3551 80MoCrV42-16 1.7218 25CrMo4 1.7220 34CrMo4 1.7225 42CrMo4	11 Free-cutting steels 1.0711 1212 1.0715 1213 1.0718 12L13 1.0726 1140 1.0737 12L14	12 Structural, cementation steels 1.0037 1015 1.0050 A570 Gr.50 1.0060 A572 Gr.65 1.5919 3115 1.7131 5115	13 Carbon steels 1.0503 1045 1.0535 1055 1.0601 1060 1.1545 W110 1.2067 L3	14 Alloy steels < 850 N/mm ² 1.2363 A2 1.3551 M50 1.7218 4130 1.7220 4135 1.7225 4140
15 淬火/回火合金钢 > 850 - < 1150 N/mm ² 1.3553 X82WCrV6-5-4 1.6580 30CrNiMo8 1.7220 34CrMo4 1.7225 42CrMo4 1.8507 34CrAlMo5	16 高抗拉强度合金钢 EN-GJS-1200-2 1.6582 34CrNiMo6v 1.7225 42CrMo4v 1.7228 50CrMo4v 1.8515 31CrMo12v	21 易切削不锈钢 1.4005 X12CrS13 1.4104 X14CrMoS17 1.4305 X10CrNiS18-9	22 奥氏体不锈钢 1.4301 X5CrNi18-10 1.4406 X2CrNiMoN17-12-2 1.4435 X2CrNiMo18-14-3 1.4541 X6CrNiTi18-10 1.4571 X6CrNiMoTi17-12-2	15 Alloy steels hard./temp. > 850 - < 1150 N/mm ² 1.3553 - 1.6580 4340 1.7220 4135 1.7225 4140 1.8507 A355CLD (K23510)	16 High tensile alloy steels EN-GJS-1200-2 1.6582 4340 1.7225 4140 1.7228 4150 1.8515 -	21 Free machining stainless steels 1.4005 416 1.4104 430F 1.4305 303	22 Austenitic stainless steels 1.4301 304 1.4406 316LN 1.4435 316L 1.4541 321 1.4571 316Ti
23 铁素体和马氏体 < 850 N/mm ² 1.4112 X90CrMoV18 1.4540 X4CrNiCuNb16-4 1.4582 X4CrNiMoNb25-7 1.4762 X10CrAl24 1.4922 X20CrMo11-1	24 铁素体和马氏体 > 850 - < 1150 N/mm ² 1.4057 X17CrNi17-2 1.4125 X105CrMo17 1.4542 X5CrNiCuNb16-4 1.4548 X5CrNiCuNb17-4-4 1.4748 X85CrMoV18-2	31 铸铁 0.6015 GG15 0.6020 GG20 0.6025 GG25 0.6030 GG30	32 球墨+ 可锻铸铁 0.7040 GGG40 0.7043 GGG40.3 0.7050 GGG50 0.7060 GGG60 0.7080 GGG80	23 Ferritic and martensitic < 850 N/mm ² 1.4112 440B 1.4540 XM12 (15-5PH) 1.4582 - 1.4762 446 1.4821 4922	24 Ferritic and martensitic > 850 - < 1150 N/mm ² 1.4057 431 1.4125 440C 1.4542 630 (17-4PH) 1.4748 -	31 Cast iron 0.6015 A48-25B 0.6020 A48-30B 0.6025 A48-40B 0.6030 A48-45B	32 Spheroidal graphite + malleable cast iron 0.7040 60-40-18 0.7043 - 0.7050 65-45-12 0.7060 80-55-06 0.7080 120-90-02
41 纯钛 3.7024 Grad1 3.7034 Grad2 3.7055 Grad3 3.7065 Grad4	42 钛合金 3.7124 TiCu2.5 Ti6Al7Nb 3.7164 TiAl6V4 (Grad5) 3.7174 TiAl6V6Sn2	51 镍合金 1 < 850 N/mm ² 1.3912 Ni36 (Invar) 2.4360 NiCu30Fe (Monel 400) 2.4816 NiCr15Fe (Inconel 600) 1.4876 X10NiCrAlTi32-20	52 镍合金 2 > 850 - < 1150 N/mm ² 2.4375 NiCu30Al (MonelK500) 2.4631 NiCr20TiAl (Nimonic 80) 2.4668 NiCr19NbMo (Inconel718)	41 Pure titanium 3.7024 Gr.1 3.7034 Gr.2 3.7055 Gr.3 3.7065 Gr.4	42 Titanium alloys 3.7124 Alloy 230 F-1295 3.7164 Gr.5 3.7174 -	51 Nickel alloys 1 < 850 N/mm ² 1.3912 K93600 2.4360 N04400 1.4816 N08800	52 Nickel alloys 2 > 850 - < 1150 N/mm ² 2.4375 N05500 (B865) 2.4631 N07080 (B637) 2.4668 N07718 (B637)
53 镍合金 3 > 1150 - ≤ 1600 N/mm ² 2.4631 NiCr20TiAl (Nimonic80) 2.4668 NiCr19NbMo (Inconel718)	61 纯铜 (电解铜) 2.0060 E-Cu57 (E-Cu)	62 短切屑黄铜 + 磷青铜 + 炮铜 2.0401 CuZn39Pb3 (Ms58) 2.0402 CuZn40Pb2 (Ms58) 2.1030 CuSn8 (Bz) 2.1096 G-CuSn5ZnPb	63 长切屑黄铜 2.0240 CuZn15 (Ms85) 2.0265 CuZn30 (Ms70) 2.0321 CuZn37 (Ms63)	53 Nickel alloys 3 > 1150 - ≤ 1600 N/mm ² 2.4631 N07080 (B637) 2.4668 N07718 (B637)	61 Pure copper (electrolytic copper) 2.0060 C11000	62 Short chip brass + phosphor bronze + gun metal 2.0401 C38500 2.0402 C37800 2.1030 C52100 2.1096 -	63 Long chip brass 2.0240 C23000 2.0265 C26000 2.0321 C27200
71 纯铝 3.0205 Al99 3.0255 Al99.5	72 铝合金 Si < 1.5% 3.1255 AlCuSiMn 3.1355 AlCuMg2 3.2315 AlMgSi1 3.3206 AlMgSi0.5 3.4345 AlZnMgCu0.5	73 铝合金 Si > 1.5% - < 10% 3.2161 G-AlSi8Cu3 3.2162 GD-AlSi8Cu3 3.2341 G-AlSi5Mg 3.2371 G-AlSi7Mg	74 铝合金 Si > 10% 镁合金 3.2381 G-AlSi10Mg 3.2382 GD-AlSi10Mg 3.2581 G-AlSi12 3.2583 G-AlSi12 (Cu)	71 Al unalloyed 3.0205 1200 3.0255 1050A	72 Al alloyed Si < 1.5% 3.1255 2014 3.1355 2024 3.2315 6082 3.3206 6060 3.4345 7020	73 Al alloyed Si > 1.5% - < 10% 3.2161 380.1 3.2162 - 3.2341 - 3.2371 A 356.2	74 Al alloyed Si > 10% Mg-alloys 3.2381 A360 3.2382 - 3.2581 A413 3.2583 413.1
81 热塑性塑料 Delrin (POM) Teflon Nylon	82 热固性塑料 Bakelit Novopan	83 玻璃纤维 加强型塑料 玻璃纤维加强型， 热塑性，热固性	参考: DIN	81 Thermoplastics Delrin (POM) Teflon Nylon	82 Duroplastics Bakelit Novopan	83 Glass fibre reinforced plastics Glass fibre reinforced, Thermo and Duroplastics	Reference: AISI/ASTM/UNS

螺纹切削 - THREAD CUTTING

Z 硬质材料 Tough materials					H 高抗拉强度材料 High tensile materials				S 特殊合金 Special alloys		SA ^{AERO} 特殊合金 Special alloys			TL 钛合金 Titanium alloys		GG 铸铁和铝铸件 Cast iron and Al casting		K		
48	48	49	50	50	52	52	54	54	56	57	58	58	57	58		60	60	66		
94	94	94	94		96		97		98	98	100	100	99	100				103		
118	118	119	120		121		121		122	123	124	124	125	124						
138		138	139		140		141		142	142	143	143	145	143						
160	160	160	161				159									159				
				181					184	184	178	178	179	178						
Z-20V	Z-20VS	Z-60V Z-62V	Z-70VS	Z-73VS	H-20	H-20TC	H-50	H-50TC	S-20VS	S-60VS	SA-20	SA-50	SA-90	TL-20VS	TL-51VS	GG-50NV	GG-50TC	GG-53TC	K-13TC	K-13VS
			SE	SE	S	SE	S	SE	S	SE	S	S							E	E
									S	S									E	E
SE	SE	SE																		
S	SE	S	SE	SE					SE											
S	SE	S	SE	SE					SE											
	S		SE	SE		S		S	SE	SE										
						E		E								E	E	E	E	
S														S						
S														SE						
S	SE	S	SE	SE					S	S	SE	SE								
			S	S							S	S	SE							
	SE		SE	SE																
					SE		SE												E	E
																			E	E
																E	E	E	E	
					L	L	L	L												
						L		L												

和空气使用最佳
 适合和空气使用

Optimal with air
 Suitable with air

受限

Limited

刚性攻丝 - RIGID TAPPING

从此页起:
From page:

M
MF
UNC
UNF
UNEF/UN/UNS
G/Rp/Rc
NPT/NPTF
W
PG/TR/SV
EG M/EG UNC/EG UNF

K

66	67
103	



RTS

62	62	63	63
102		102	
126		126	
146		146	
		161	

Z

50	50
94	
120	
139	
181	



Vc (m/min)			
\emptyset M6-M10	\emptyset M12-M16	\emptyset M20-M30	\emptyset M33-M42
32	28	22	18
30	25	20	15
24	20	16	12
24	20	16	12
15	12	8	6
30	25	20	15
30	25	20	15
35	30	25	20
32	28	22	18
30	25	20	15

K. 13TC	K. 13VS	
E	E	11
E	E	12
E	E	13
E	E	14
E	E	15
		16
		21
		22
		23
		24
E	E	31
E	E	32
		41
		42
		51
		52
		53
E	E	61
E	E	62
E	E	63
		71
		72
		73
E	E	74
		81
		82
		83

Vc (m/min) < \emptyset 20 mm (Guide line) 带涂层 VS Coated VS
20 – 40
20 – 40
16 – 24
16 – 24
6 – 12
20 – 40
6 – 12
6 – 12
4 – 8
20 – 40
20 – 40
6 – 12
10 – 20
20 – 40
30 – 50
20 – 40
20 – 40

RTS-20VS	RTS-23VS	RTS-62VS	RTS-65VS	Z 70VS	Z 73VS	
E	E	E	E			11
E	E	E	E			12
E	E	E	E			13
E	E	E	E	E	E	14
E	E	E	E	E	E	15
						16
E	E	E	E			21
E	E	E	E	E	E	22
				E	E	23
				E	E	24
E	E	E	E			31
E	E	E	E			32
						41
						42
				E	E	51
						52
						53
E	E	E	E	E	E	61
						62
E	E	E	E			63
						71
E	E	E	E			72
E	E	E	E			73
E	E	E	E			74
						81
						82
						83

S 使用切削油最佳
S Suitable with cutting oil

S Optimal with cutting oil
S Suitable with cutting oil

E 使用乳化液最佳
E Suitable with emulsion

E Optimal with emulsion
E Suitable with emulsion

螺纹挤压 - THREAD FORMING

FS 标准 < Ø 3 mm		FPS 无凸角多边形 Passive polygon form					FAS 带凸角多边形 Active polygon form		
68	69	70	70	70	70	72	73	73	74
			104			104		105	
127						127		127	
147						147		147	
						162		162	



Vc (m/min)
< Ø 20 mm
(Guide line)
带涂层 VS + CN
Coated VS + CN

Vc (m/min)	FS-80VS	FS-80DL	FPS-80CN	FPS-81CN	FPS-80VS	FPS-81VS	FPS-84VS	FAS-80VS	FAS-81VS	FAS-84VS	
20 - 40	S	S			SE	SE	SE				11
20 - 40	SE	S			SE	SE	SE	SE	SE	SE	12
20 - 30	SE	S			SE	SE	SE	SE	SE	SE	13
20 - 30	S	S			SE	SE	SE	SE	SE	SE	14
10 - 15	S				S	S	SE	S	S	SE	15
											16
10 - 20	S	SE			S	S	SE	S	S	SE	21
10 - 15		SE						SE	SE	SE	22
6 - 12		SE						S	S	SE	23
6 - 12		S			S	S	S	SE	SE	SE	24
											31
											32
10 - 20		S						S	S	S	41
											42
10 - 15		S						SE	SE	SE	51
											52
											53
10 - 20	S	S						SE	SE	SE	61
											62
20 - 30	SE	SE	SE	SE	S	S	S	S	S	S	63
20 - 40		SE	SE	SE							71
20 - 40		SE	SE	SE							72
20 - 40		SE	SE	SE							73
											74
											81
											82
											83













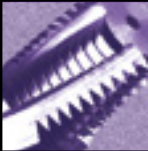

S 使用切削油最佳
S 适合使用切削油

S Optimal with cutting oil
S Suitable with cutting oil

E 使用乳化液最佳
E 适合使用乳化液

E Optimal with emulsion
E Suitable with emulsion

	<p>螺纹切削 Thread Cutting</p> 		<p>刚性攻丝 Rigid Tapping</p> 
<p>M</p> <p>N 22-45/76-78/285 W 46-47 Z 48-51 H 52-55</p> <p>S 56-57 SA 57-59 TL 58-59 GG 60-61</p> <p>K 66-67</p> <p>MF</p> <p>N 84-93/106-108 Z 94-95 H 96-97 S 98</p> <p>SA 99-101 TL 100-101 K 103</p> <p>UNC, UNC(J)</p> <p>N 114-117/128-129 Z 118-120 H 121 S 122-123</p> <p>SA 124-125 TL 124</p> <p>UNF, UNF(J), UNJF, UNEF, UN, UNS</p> <p>N 134-137/148-151 Z 138-139 H 140-141 S 142</p> <p>SA 143-145 TL 143-144</p> <p>G (BSP), Rp, Rc, W, SV Schaublin</p> <p>N 156-158/163-167 W 159 Z 160-161 H 159</p> <p>GG 159</p> <p>NPT, NPTF, PG, TR</p> <p>N 170-173</p> <p>EG M, EG UNC, EG UNF</p> <p>N 176-177/180/183 Z 181/184 S 184 SA 178-179/182/184-185</p> <p>TL 178/182/185</p>		<p>M</p> <p>RTS 62-65 Z.70/Z.73 50-51 K 66-67</p> <p>MF</p> <p>RTS 102 Z.70 94-95 K 103</p> <p>UNC</p> <p>RTS 126 Z.70 120</p> <p>UNF</p> <p>RTS 146 Z.70 139</p> <p>G (BSP)</p> <p>RTS 161 Z.70 161</p> <p>EG UNC, EG UNF</p> <p>Z.70 181/184</p>	
			<p>螺纹挤压 Thread Forming</p> 
 <p>王冠形丝锥 Crown taps</p> 		 <p>钻攻一体丝锥 Combination drill/taps</p> 	
<p>M, MF</p> <p>N 187-188</p> <p>UN, G (BSP)</p> <p>N 189</p>		<p>M, MF</p> <p>N 192</p> <p>UNC, G (BSP), PG</p> <p>N 193</p>	

	<p>螺纹旋风铣削 Thread Whirling</p> 		<p>螺纹量规 Thread gauges</p> 	
<p>S, M, MF, UNC, UNF GW 206-213</p>		<p>M D 266-267</p>		
	<p>螺纹铣削 Thread Milling</p> 	<p>MF D 268-271</p>		
<p>M GF 214-216 GFH 214 GFS 225-227 GFM 236 BGF 240-242</p> <p>MF GF 217-218 GFS 228-229 GFM 236 BGF 243</p> <p>UNC, UNF, UNEF, UN, UNS GF 219-222 GFS 230-233 GFM 237</p> <p>G (BSP), PG GF 223 GFS 234 GFM 238</p> <p>NPT, NPTF GF 224 GFS 235 GFM 239</p>		<p>UNC, UNF, UNEF D 272-273</p> <p>G (BSP), PG D 274</p> <p>NPT, NPTF D 275</p> <p>EG M, EG UNC, EG UNF D 276</p>		
 <p>板牙 Dies</p> 			<p>攻丝夹头 SRT Tapping chucks SRT</p> 	
		<p>HSK 278 BT40 278 SK40/SK50 279 DIN1835 B 280-281</p>		
				
				
		<p>D 282/283 F 284 D 285 D 286-287</p>		
<p>M N 246/260/262/263 Z 247/260</p> <p>MF N 248-250/261/262 Z 248-249</p> <p>UNC, UNF, UNEF, UN, UNS N 251-253</p> <p>G (BSP), R N 254/256/263 Z 255 MS 255</p> <p>NPT, NPTF, PG, TR, W / W Schaublin N 257-259/263 N 167</p>			<p>切割速度，换算表，底孔直径， 车削直径 技术调查表 发货和付款条件</p> <p>Cutting speeds, conversion tables, core hole diameters, turned diameters Technical questionnaire Delivery and payment conditions</p>	

M

MF

UNC, UNF, UNEF, UN, UNS

UNF, UNF(U), UNJF, UNEF, UN, UNS

G, Rp, Rc, W, SV

NPT, NPTF, PG, TR

EG M, EG UN

王冠形丝锥
Crown taps

钻攻一体丝锥
Combination drill/taps

































































目录 - 机用丝锥 DIN 13

Directory - Machine taps DIN 13

		N						
特点 Characteristics								
				V	TiN TiCN			V
洞型 Hole type								
		N310-3	N320-3 N320-4	N320V-3 N320V-4	N320TN-3/4 N320TC-3/4	N321-3 N321-4	N330-3 N330-4	N330V-3 N330V-4
DIN 标准 长型 DIN long	DIN 371	22	22/24	24	24	30	30	30
超长型 Extra-long	DC							
ISO 标准 短型 ISO short	ISO 529							
DIN 标准 短型 DIN short	DIN 352							
DIN 标准 长型 DIN long	~DIN 2174							
公差 Tolerance	ISO 2 6H	22	22/24	24	24	30	30	30
尺寸偏大 Oversize	ISO 3 6G		28	28				
尺寸偏大 Oversize	7G		28					
尺寸偏大 Oversize	+ 0.10 mm + 0.20 mm		28					
精密公差 Fine tolerance	ISO 1 4H		26					
LH 左旋螺纹 LH Left hand thread	ISO 2 6H	22	26	26				
		N410-3	N420-4	N420V-4	N420TN-4 N420TC-4	N421-4	N430-4	N430V-4
DIN 标准 长型 DIN long	DIN 376	23	25	25	25	31	31	31
超长型 Extra-long	DC							
ISO 标准 短型 ISO short	ISO 529							
DIN 标准 短型 DIN short	DIN 352							
DIN 标准 长型 DIN long	~DIN 2174							
公差 Tolerance	ISO 2 6H	23	25	25	25	31	31	31
尺寸偏大 Oversize	ISO 3 6G		29	29				
尺寸偏大 Oversize	7G		29					
尺寸偏大 Oversize	+ 0.10 mm + 0.20 mm		29/31					
精密公差 Fine tolerance	ISO 1 4H		27					
LH 左旋螺纹 LH Left hand thread	ISO 2 6H	23	27	27				

























N

 R15 	 R40	 R40 	 R40  	 R40  	 R40 	 R40  		 
								
								
N350-3 N350V-3	N360-3	N360V-3	N360TN-3 N360TC-3	N360-5 N360V-5	N361-3	N362V-3	N520-4	N520V-4
32	34	34	34	40	40	40	42	42
32	34	34	34	40	40	40	42	42
	36	36						
	38	38						
	38							
	36	36						
N450-3 N450V-3	N460-3	N460V-3	N460TN-3 N460TC-3	N460-5 N460V-5	N461-3	N462V-3	N620-4	N620V-4
33	35	35	35	41	41	41	43	43
33	35	35	35	41	41	41	43	43
	37	37						
	39	39						
	39							
	37	37						

		N								
特点 Characteristics		 TiN	 R40	 R40	 V	 R40	 TiN		 R40	
										
洞型 Hole type										
		N520TN-4	N560-3	N560V-3	N560TN-3	N1120-4	N1160-3	N1110-1-2-3-S		
DIN 标准 长型 DIN long	DIN 371									
超长型 Extra-long	DC	42	44	44	44					
ISO 标准 短型 ISO short	ISO 529					78	78	76		
DIN 标准 短型 DIN short	DIN 352									
DIN 标准 长型 DIN long	~DIN 2174									
公差 Tolerance	ISO 2 6H	42	44	44	44	78	78	76		
尺寸偏大 Oversize	ISO 3 6G									
尺寸偏大 Oversize	7G									
尺寸偏大 Oversize	+ 0.10 mm + 0.20 mm									
精密公差 Fine tolerance	ISO 1 4H									
LH 左旋螺纹 LH Left hand thread	ISO 2 6H									
		N620TN-4	N660-3	N660V-3	N660TN-3	N1220-4	N1260-3	N1210-1-2-3-S		
DIN 标准 长型 DIN long	DIN 376									
超长型 Extra-long	DC	43	45	45	45					
ISO 标准 短型 ISO short	ISO 529					78	78	77		
DIN 标准 短型 DIN short	DIN 352									
DIN 标准 长型 DIN long	~DIN 2174									
公差 Tolerance	ISO 2 6H	43	45	45	45	78	78	77		
尺寸偏大 Oversize	ISO 3 6G									
尺寸偏大 Oversize	7G									
尺寸偏大 Oversize	+ 0.10 mm + 0.20 mm									
精密公差 Fine tolerance	ISO 1 4H									
LH 左旋螺纹 LH Left hand thread	ISO 2 6H									

























目录 - 机用丝锥 DIN 13
Directory - Machine taps DIN 13

	W				Z			
								
	DL			DL	V	VS	V	VS
		 NEW		 NEW				
								
	W320-3 W320-4	W320DL-3 W320DL-4	W360-3	W360DL-3	Z320V-3 Z320V-4	Z320VS-4	Z360V-3 Z362V-3	Z360VS-3 Z362VS-3
	46	46	47	47	48	48	49	50
	46	46	47	47	48	48	49	50
	W420-4	W420DL-4	W460-3	W460DL-3	Z420V-4	Z420VS-4	Z462V-3	Z462VS-3
	46	46	47	47	48	48	49	51
	46	46	47	47	48	48	49	51



目录 - 机用丝锥 DIN 13
Directory - Machine taps DIN 13

		Z		H		S		SA
特点 Characteristics								
		VS	VS	TiCN	TiCN	VS	VS	
								
洞型 Hole type								
		Z370VS-3	Z373VS-3	H320-4 H320TC-4	H350-3 H350TC-3	S320VS-4	S360VS-3	SA320-4
DIN 标准 长型 DIN long	DIN 371	50	50	52	54	56	57	58
超长型 Extra-long	DC							
ISO 标准 短型 ISO short	ISO 529							
DIN 标准 短型 DIN short	DIN 352							
DIN 标准 长型 DIN long	~DIN 2174							
公差 Tolerance	ISO 2 6H	50	50	52	54	56	57	58
尺寸偏大 Oversize	ISO 3 6G				54			
尺寸偏大 Oversize	7G							
尺寸偏大 Oversize	+ 0.10 mm + 0.20 mm							
精密公差 Fine tolerance	ISO 1 4H	50				56		58
LH 左旋螺纹 LH Left hand thread	ISO 2 6H							
		Z470VS-3	Z473VS-3	H420-4 H420TC-4	H450-3 H450TC-3	S420VS-4	S460VS-3	SA420-4
DIN 标准 长型 DIN long	DIN 376	51	51	53	55	56	57	59
超长型 Extra-long	DC							
ISO 标准 短型 ISO short	ISO 529							
DIN 标准 短型 DIN short	DIN 352							
DIN 标准 长型 DIN long	~DIN 2174							
公差 Tolerance	ISO 2 6H	51	51	53	55	56	57	59
尺寸偏大 Oversize	ISO 3 6G				55			
尺寸偏大 Oversize	7G							
尺寸偏大 Oversize	+ 0.10 mm + 0.20 mm							
精密公差 Fine tolerance	ISO 1 4H							59
LH 左旋螺纹 LH Left hand thread	ISO 2 6H							

























目录 - 机用丝锥 DIN 13
Directory - Machine taps DIN 13









SA		TL		GG			K		
		VS	VS			TiCN	TiCN		
SA350-3	SA390-3	TL320VS-4	TL351VS-3	GG350NV-3 GG550NV-3	GG350TC-3	GG353TC-3	K313TC-3		
58	57	58	58	60	60	60	66		
				60					
58	57	58	58	60	60	60	66		
58	57	58	58						
SA450-3		TL420VS-4	TL451VS-3	GG450NV-3 GG650NV-3	GG450TC-3	GG453TC-3	K413TC-3 K613TC-3	K613VS-3	
59		59	59	61	61	61	66		
				61			67	67	
59		59	59	61	61	61	66/67	67	
59		59	59						

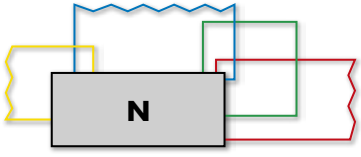

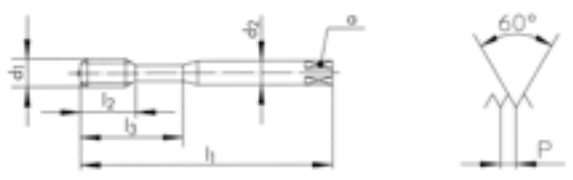
目录 - 机用丝锥 DIN 13

Directory - Machine taps DIN 13

		RTS						
特点 Characteristics								
		VS	VS	VS	VS	E 1.5 x P VS	VS	VS
								
洞型 Hole type								
		RTS320VS-4	RTS323VS-4	RTS360VS-3 RTS362VS-3	RTS365VS-3	RTS362VS-5 RTS365VS-5	RTS523VS-4	RTS565VS-3
DIN 标准 长型 DIN long	DIN 371	62	62	63	63	64		
超长型 Extra-long	DC						65	65
ISO 标准 短型 ISO short	ISO 529							
DIN 标准 短型 DIN short	DIN 352							
DIN 标准 长型 DIN long	~DIN 2174							
公差 Tolerance	ISO 2 6H	62	62	63	63	64	65	65
尺寸偏大 Oversize	ISO 3 6G			64				
尺寸偏大 Oversize	7G							
尺寸偏大 Oversize	+ 0.10 mm + 0.20 mm							
精密公差 Fine tolerance	ISO 1 4H							
LH 左旋螺纹 LH Left hand thread	ISO 2 6H							
		RTS420VS-4	RTS423VS-4	RTS462VS-3	RTS465VS-3		RTS623VS-4	RTS665VS-3
DIN 标准 长型 DIN long	DIN 376	62	62	63	63			
超长型 Extra-long	DC						65	65
ISO 标准 短型 ISO short	ISO 529							
DIN 标准 短型 DIN short	DIN 352							
DIN 标准 长型 DIN long	~DIN 2174							
公差 Tolerance	ISO 2 6H	62	62	63	63		65	65
尺寸偏大 Oversize	ISO 3 6G							
尺寸偏大 Oversize	7G							
尺寸偏大 Oversize	+ 0.10 mm + 0.20 mm							
精密公差 Fine tolerance	ISO 1 4H							
LH 左旋螺纹 LH Left hand thread	ISO 2 6H							

										N310-3	N310-3 LH	N320-3
												
												
												
										ISO 2 6H	ISO 2 6H	ISO 2 6H
Ø d ₁ M	P mm	l ₁ mm	l ₂ mm	l ₃ mm	d ₂ mm	a mm			ID	ID	ID	
1	0.25	40	5.5		2.5	2.1	3	0.75	150167			
1.1	0.25	40	5.5		2.5	2.1	3	0.85	174745			
1.2	0.25	40	5.5		2.5	2.1	3	0.95	150168			
1.4	0.30	40	7.0		2.5	2.1	3	1.10	150169			
1.5	0.30	40	7.0		2.5	2.1	3	1.20	174752			
1.6	0.35	40	8.0		2.5	2.1	3	1.25	174753			
1.7	0.35	40	8.0		2.5	2.1	3	1.35	174754			
1.8	0.35	40	8.0		2.5	2.1	3	1.45	174755			
2	0.40	45	8.0		2.8	2.1	3	1.60	101439	111460		
2.2	0.45	45	9.0		2.8	2.1	3	1.75	174756			
2.3	0.40	45	9.0		2.8	2.1	3	1.90	174757			
2.5	0.45	50	10.0		2.8	2.1	*3	2.05	101440	111461	* 101461	
2.6	0.45	50	10.0		2.8	2.1	3	2.15	101441			
3	0.50	56	12.0	18	3.5	2.7	*3	2.50	101442	111462	* 101462	
3.5	0.60	56	13.0	20	4.0	3.0	*3	2.90	101443		* 101463	
4	0.70	63	14.0	21	4.5	3.4	*3	3.30	101444	111464	* 101464	
5	0.80	70	15.0	25	6.0	4.9	*3	4.20	101445	111465	* 101465	
6	1.00	80	17.0	30	6.0	4.9	*3	5.00	101446	111466	* 101466	
8	1.25	90	20.0	35	8.0	6.2	3	6.80	101447			
10	1.50	100	22.0	39	10.0	8.0	3	8.50	101438			

* N320-3 =  2

≤ M1.5

**ISO 1
4H**

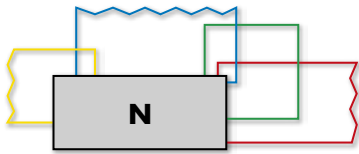

N410-3

N410-3 LH

N410-3



N410-3 LH



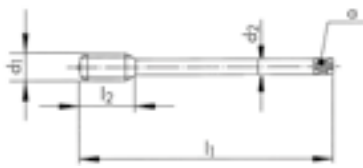

LH



ISO 2
6H

ISO 2
6H

$\varnothing d_1$ M	P mm	l_1 mm	l_2 mm	d_2 mm	a mm		
3	0.50	56	12.0	2.2	1.8	3	2.50
4	0.70	63	14.0	2.8	2.1	3	3.30
5	0.80	70	15.0	3.5	2.7	3	4.20
6	1.00	80	17.0	4.5	3.4	3	5.00
7	1.00	80	17.0	5.5	4.3	3	6.00
8	1.25	90	20.0	6.0	4.9	3	6.80
10	1.50	100	22.0	7.0	5.5	3	8.50
12	1.75	110	24.0	9.0	7.0	3	10.20
14	2.00	110	28.0	11.0	9.0	3	12.00
16	2.00	110	30.0	12.0	9.0	3	14.00
18	2.50	125	33.0	14.0	11.0	3	15.50
20	2.50	140	36.0	16.0	12.0	3	17.50
22	2.50	140	36.0	18.0	14.5	3	19.50
24	3.00	160	39.0	18.0	14.5	4	21.00
27	3.00	160	42.0	20.0	16.0	4	24.00
30	3.50	180	45.0	22.0	18.0	4	26.50
33	3.50	180	48.0	25.0	20.0	4	29.50
36	4.00	200	51.0	28.0	22.0	4	32.00
39	4.00	200	55.0	32.0	24.0	4	35.00
42	4.50	200	55.0	32.0	24.0	4	37.50
48	5.00	250	63.0	36.0	29.0	4	43.00
56	5.50	280	71.0	45.0	35.0	5	50.50

ID

ID

101897

101924

101942

101953

142645

111491

101958

111492

101866

111478

101870

111479

101874

111480

101880

111481

101883

111482

101885

125530

101888

101891

111485

101895

111486

101901

111487

101907

101915











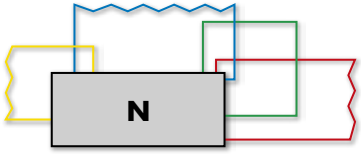





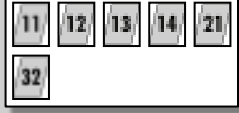



111488

101922

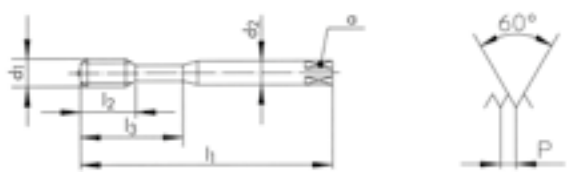







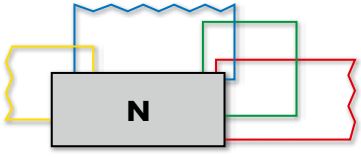

101932



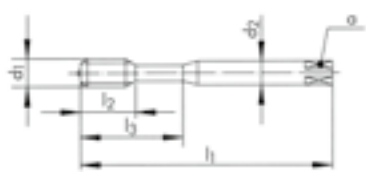





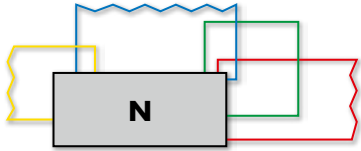

111489



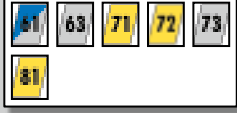

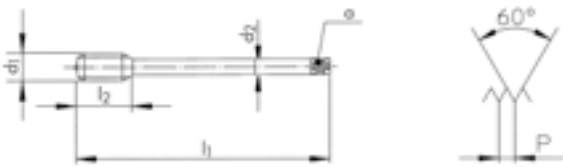

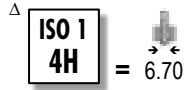

111447

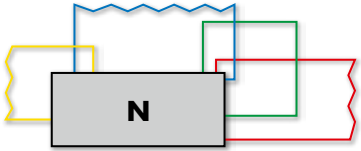
									N320-4	N320V-4	N320TN-4	N320TC-4
												
N320-4												
N320V-4	 V											
N320TN-4	 TiN											
N320TC-4	 TiCN											
												
												
Ø d ₁ M	P mm	l₁ mm	l₂ mm	l₃ mm	d₂ mm	a mm			ID	ID	ID	ID
*1	0.25	40	5.5		2.5	2.1	2	0.75	111467			
*1.1	0.25	40	5.5		2.5	2.1	2	0.85	111468			
*1.2	0.25	40	5.5		2.5	2.1	2	0.95	111469			
*1.4	0.30	40	7.0		2.5	2.1	2	1.10	111470			
*1.5	0.30	40	7.0		2.5	2.1	2	1.20	111471			
*1.6	0.35	40	8.0		2.5	2.1	2	1.25	101454			
*1.7	0.35	40	8.0		2.5	2.1	2	1.35	101455			
*1.8	0.35	40	8.0		2.5	2.1	2	1.45	101456			
*2	0.40	45	8.0		2.8	2.1	2	1.60	101458	101536	101528	152900
*2.2	0.45	45	9.0		2.8	2.1	2	1.75	101459			
*2.3	0.40	45	9.0		2.8	2.1	2	1.90	101460			
2.5	0.45	50	10.0		2.8	2.1	3	2.05	101483	101545	101530	101522
2.6	0.45	50	10.0		2.8	2.1	3	2.15	101484			
3	0.50	56	12.0	18	3.5	2.7	3	2.50	101485	101546	101531	101523
3.5	0.60	56	13.0	20	4.0	3.0	3	2.90	101491	101547		
4	0.70	63	14.0	21	4.5	3.4	3	3.30	101495	101548	101532	101524
5	0.80	70	15.0	25	6.0	4.9	3	4.20	101499	101549	101533	101525
6	1.00	80	17.0	30	6.0	4.9	3	5.00	101503	101550	101534	101526
8	1.25	90	20.0	35	8.0	6.2	3	6.80	101506	101551	101535	101527
10	1.50	100	22.0	39	10.0	8.0	3	8.50	101481	101544	101529	101521
<p>* N320-3 / N320V-3 N320TN-3 / N320TC-3</p> 									<p>≤ M1.5</p> 			

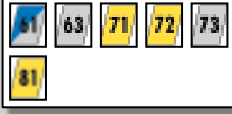
								N420-4	N420V-4	N420TN-4	N420TC-4
N420-4											
N420V-4		V									
N420TN-4		TiN									
N420TC-4		TiCN									
								ISO 2 6H	ISO 2 6H	ISO 2 6H	ISO 2 6H
∅ d ₁ M	P mm	l ₁ mm	l ₂ mm	d ₂ mm	α mm			ID	ID	ID	ID
3	0.50	56	12.0	2.2	1.8	3	2.50	102119	143418		
4	0.70	63	14.0	2.8	2.1	3	3.30	102146	102279		
5	0.80	70	15.0	3.5	2.7	3	4.20	102171	102280	146297	
6	1.00	80	17.0	4.5	3.4	3	5.00	102182	102282	147439	
7	1.00	80	17.0	5.5	4.3	3	6.00	102189	144713		
8	1.25	90	20.0	6.0	4.9	3	6.80	102195	102285	102251	102233
9	1.25	90	20.0	7.0	5.5	3	7.80	102202			
10	1.50	100	22.0	7.0	5.5	3	8.50	102061	102263	102240	102228
11	1.50	100	19.0	8.0	6.2	3	9.50	162770			
12	1.75	110	24.0	9.0	7.0	3	10.20	102072	102265	102243	102229
14	2.00	110	28.0	11.0	9.0	3	12.00	102081	102267	102245	
16	2.00	110	30.0	12.0	9.0	3	14.00	102090	102269	102247	102231
18	2.50	125	33.0	14.0	11.0	3	15.50	102097	102271		
20	2.50	140	36.0	16.0	12.0	3	17.50	102101	102273	102248	102232
22	2.50	140	36.0	18.0	14.5	3	19.50	102106	102275		
24	3.00	160	39.0	18.0	14.5	4	21.00	102110	102278	144220	163736
27	3.00	160	42.0	20.0	16.0	4	24.00	102117	143856		
30	3.50	180	45.0	22.0	18.0	4	26.50	102124	105124		
33	3.50	180	48.0	25.0	20.0	4	29.50	102130	146968		
36	4.00	200	51.0	28.0	22.0	4	32.00	102137	143430		
39	4.00	200	55.0	32.0	24.0	4	35.00	102144	158724		
42	4.50	200	55.0	32.0	24.0	4	37.50	102158	143107		
45	4.50	220	59.0	36.0	29.0	4	40.50	* 110225			
48	5.00	250	63.0	36.0	29.0	4	43.00	110226	157517		
56	5.50	280	71.0	45.0	35.0	5	50.50	110229	158178		

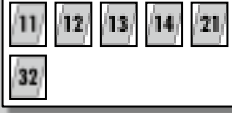

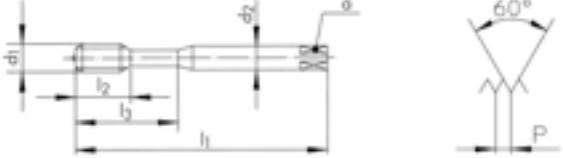
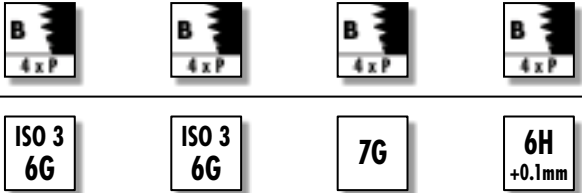







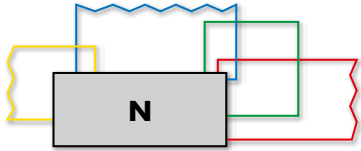







										N320-4	N320-4 LH	N320V-4 LH	
													
N320-4													
N320-4 LH		LH											
N320V-4 LH		V	LH										
 													
										ISO 1 4H	ISO 2 6H	ISO 2 6H	
Ø d ₁ M	P mm	l ₁ mm	l ₂ mm	l ₃ mm	d ₂ mm	a mm				ID	ID	ID	
*2	0.40	45	8.0		2.8	2.1	2	1.60		162503	111472	162771	
2.5	0.45	50	10.0		2.8	2.1	3	2.05		159345			
3	0.50	56	12.0	18	3.5	2.7	3	2.50		101487	111473	162772	
4	0.70	63	14.0	21	4.5	3.4	3	3.30		101493	111474	162773	
5	0.80	70	15.0	25	6.0	4.9	3	4.20		101497	111475	162774	
6	1.00	80	17.0	30	6.0	4.9	3	5.00		101501	111476	162775	
8	1.25	90	20.0	35	8.0	6.2	3	6.80	Δ	* 146482			
10	1.50	100	22.0	39	10.0	8.0	3	8.50		* 146484			
<p>* N320-3 </p> <p>Δ ISO 1 4H =  6.70</p>													



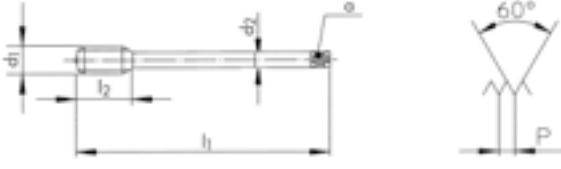
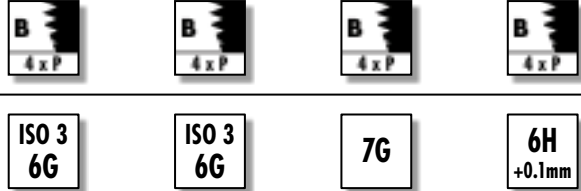







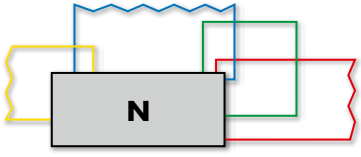





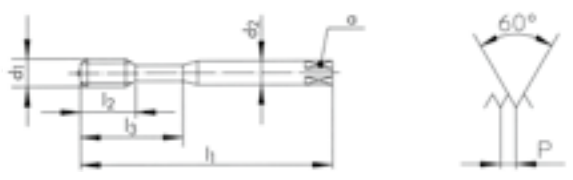

									N420-4	N420-4 LH	N420V-4 LH	
												
N420-4												
N420-4 LH	 LH											
N420V-4 LH	 V LH											
												
												
$\varnothing d_1$ M	P mm	l_1 mm	l_2 mm	d_2 mm	a mm				ID	ID	ID	
8	1.25	90	20.0	6.0	4.9	3	Δ	6.80	102193	102198	142621	
10	1.50	100	22.0	7.0	5.5	3		8.50	102059	102064	143287	
12	1.75	110	24.0	9.0	7.0	3		10.20	102070	102040	146583	
14	2.00	110	28.0	11.0	9.0	3		12.00		102084	146563	
16	2.00	110	30.0	12.0	9.0	3		14.00		102093	143108	
20	2.50	140	36.0	16.0	12.0	3		17.50		102103	145579	
24	3.00	160	39.0	18.0	14.5	4		21.00		111493	145578	
30	3.50	180	45.0	22.0	18.0	4		26.50		* 111494		
												

									N320-4	N320V-4	N320-4	N320-4			
															
N320-4															
N320V-4	 V														
															
Ø d ₁ M	P mm	l ₁ mm	l ₂ mm	l ₃ mm	d ₂ mm	a mm			ID	6H + mm	ID	6H + mm	ID	6H + mm	ID
*2	0.40	45	8.0		2.8	2.1	2	1.60	101457	0.019	143584	0.019			
2.5	0.45	50	10.0		2.8	2.1	3	2.05	101482	0.020	150522	0.020			
3	0.50	56	12.0	18	3.5	2.7	3	2.50	101486	0.020	143116	0.020	101489	0.036	101488
3.5	0.60	56	13.0	20	4.0	3.0	3	2.95	101490	0.021					
4	0.70	63	14.0	21	4.5	3.4	3	3.35	101494	0.022	143087	0.022	101496	0.041	111522
5	0.80	70	15.0	25	6.0	4.9	3	4.25	101498	0.024	143088	0.024	101500	0.044	111523
6	1.00	80	17.0	30	6.0	4.9	3	5.00	101502	0.026	143089	0.026	101504	0.050	111524
8	1.25	90	20.0	35	8.0	6.2	3	6.80	101505	0.028	143604	0.028			











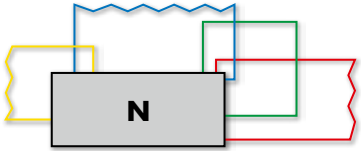





* N320-3 / N320V-3



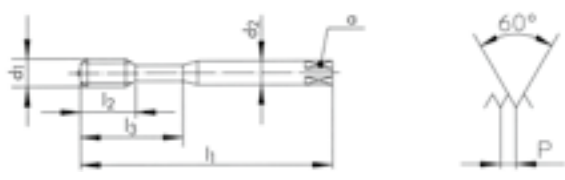







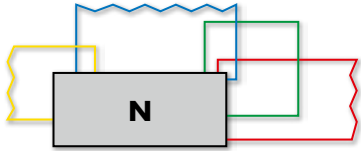











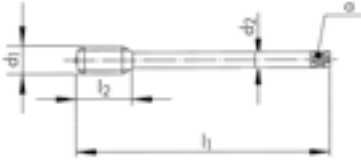









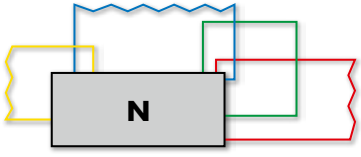

									N420-4	N420V-4	N420-4	N420-4			
															
N420-4									   						
N420V-4	 V								   						
															
$\varnothing d_1$ M	P mm	l_1 mm	l_2 mm	d_2 mm	α mm			6H mm	ID	6H + mm	ID	6H + mm	ID	6H + mm	ID
8	1.25	90	20.0	6.0	4.9	3		6.80	102194	0.028	145246	0.028	102199	0.052	102196
10	1.50	100	22.0	7.0	5.5	3		8.50	102060	0.032	143726	0.032	102065	0.060	102062
12	1.75	110	24.0	9.0	7.0	3		10.30	102071	0.034	145655	0.034	102076	0.066	102073
16	2.00	110	30.0	12.0	9.0	3		14.00	135531	0.038	162795	0.038	102094	0.072	102091

									N321-4	N330-4	N330V-4	
												
N321-4												
N330-4												
N330V-4												
												
												
												
Ø d ₁ M	P mm	l ₁ mm	l ₂ mm	l ₃ mm	d ₂ mm	a mm			ID	ID	ID	
*1	0.25	40	5.5		2.5	2.1	2	0.75		101558		
*1.1	0.25	40	5.5		2.5	2.1	2	0.85		* 101559		
*1.2	0.25	40	5.5		2.5	2.1	2	0.95		101560		
*1.4	0.30	40	7.0		2.5	2.1	2	1.10		101561		
*1.6	0.35	40	8.0		2.5	2.1	2	1.25		101562	151246	
*1.7	0.35	40	8.0		2.5	2.1	2	1.35		* 101563		
*2	0.40	45	8.0		2.8	2.1	2	1.60	101552	105125	101572	
*2.2	0.45	45	9.0		2.8	2.1	2	1.75		* 105126		
*2.3	0.40	45	9.0		2.8	2.1	2	1.90		* 105127		
2.5	0.45	50	10.0		2.8	2.1	*3	2.05	101553	101565	101573	
2.6	0.45	50	10.0		2.8	2.1	2	2.15		* 101566		
3	0.50	56	12.0	18	3.5	2.7	*3	2.50	101555	101567	101574	
3.5	0.60	56	13.0	20	4.0	3.0	2	2.90		101568		
4	0.70	63	14.0	21	4.5	3.4	3	3.30	101557	101569	101576	
5	0.80	70	15.0	25	6.0	4.9	3	4.20		101570	101577	
6	1.00	80	17.0	30	6.0	4.9	3	5.00		101571	101578	
<p>* N321-3 / N330-3 / N330V-3  * N330-4 =  2</p> <p>* N330V-4 =  2</p>									<p>≤ M1.5 </p>			



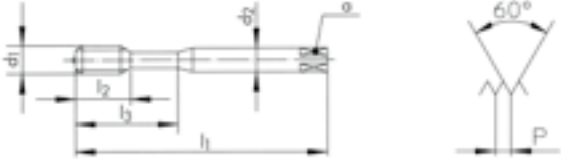

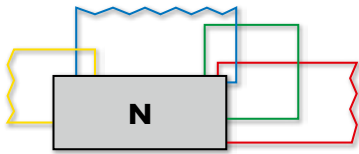

								N420-4	N421-4	N430-4	N430V-4
N420-4											
N421-4											
N430-4											
N430V-4											
$\varnothing d_1$	P	l_1	l_2	d_2	α		$\pm 6H$	ID	ID	ID	ID
M	mm	mm	mm	mm	mm		$\rightarrow \leftarrow$				
4	0.70	63	14.0	2.8	2.1	3	3.30		102293		
5	0.80	70	15.0	3.5	2.7	3	4.20		102294		
6	1.00	80	17.0	4.5	3.4	3	5.00		102295		
8	1.25	90	20.0	6.0	4.9	3	6.80	102197	102296	102301	102306
10	1.50	100	22.0	7.0	5.5	3	8.50	102063	102286	102297	102302
12	1.75	110	24.0	9.0	7.0	3	10.20	102074	102287	102298	102303
14	2.00	110	28.0	11.0	9.0	3	12.00		* 102288		
16	2.00	110	30.0	12.0	9.0	3	14.00	102092	102289		

									N350-3	N350V-3		
									 			
N350-3												
N350V-3	 V											
									 			
												
									 			
									 			
Ø d ₁ M	P mm	l ₁ mm	l ₂ mm	l ₃ mm	d ₂ mm	a mm			ID	ID		
2	0.40	45	8.0		2.8	2.1	2	1.60	101580	101593		
2.3	0.40	45	9.0		2.8	2.1	2	1.90	101581			
2.5	0.45	50	10.0		2.8	2.1	2	2.05	101582	101594		
2.6	0.45	50	10.0		2.8	2.1	2	2.15	101583			
3	0.50	56	12.0	18	3.5	2.7	2	2.50	101584	101595		
3.5	0.60	56	13.0	20	4.0	3.0	2	2.90	101585			
4	0.70	63	14.0	21	4.5	3.4	2	3.30	101587	101596		
5	0.80	70	15.0	25	6.0	4.9	3	4.20	101589	101597		
6	1.00	80	17.0	30	6.0	4.9	3	5.00	101591	101598		
8	1.25	90	20.0	35	8.0	6.2	3	6.80	101592	146810		
10	1.50	100	22.0	39	10.0	8.0	3	8.50	101579	147217		

									N450-3	N450V-3		
									<p>N450-3</p>  	 		 
<p>N450V-3</p>   	 											
 									 			
									 			
$\varnothing d_1$ M	P mm	l_1 mm	l_2 mm	d_2 mm	a mm			ID	ID			
8	1.25	90	20.0	6.0	4.9	3	6.80	102327	102334			
10	1.50	100	22.0	7.0	5.5	3	8.50	102314	102329			
12	1.75	110	24.0	9.0	7.0	3	10.20	102317	102330			
14	2.00	110	28.0	11.0	9.0	3	12.00	102319	145487			
16	2.00	110	30.0	12.0	9.0	3	14.00	102321	102331			
20	2.50	140	36.0	16.0	12.0	4	17.50	102324	102332			
24	3.00	160	39.0	18.0	14.5	4	21.00	102325	102333			

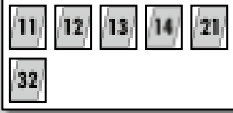
									N360-3	N360V-3	N360TN-3	N360TC-3
									<p>N360-3  </p> <p>N360V-3  V </p> <p>N360TN-3  TiN </p> <p>N360TC-3  TiCN </p>			
												
												
Ø d ₁ M	P mm	l ₁ mm	l ₂ mm	l ₃ mm	d ₂ mm	a mm			ID	ID	ID	ID
2	0.40	45	7.0		2.8	2.1	2	1.60	101618	101708	101697	146842
2.2	0.45	45	8.0		2.8	2.1	2	1.75	101619			
2.3	0.40	45	8.0		2.8	2.1	2	1.90	101620			
2.5	0.45	50	9.0		2.8	2.1	2	2.05	101622	101709	101698	101689
2.6	0.45	50	9.0		2.8	2.1	2	2.15	101623	101710		
3	0.50	56	5.5	18	3.5	2.7	3	2.50	101626	101711	101699	101690
3.5	0.60	56	6.5	20	4.0	3.0	3	2.90	101630	142625		
4	0.70	63	7.5	21	4.5	3.4	3	3.30	101635	101713	101700	101691
4.5	0.75	70	9.0	25	6.0	4.9	3	3.75	101639			
5	0.80	70	9.0	25	6.0	4.9	3	4.20	101644	101715	101701	101692
6	1.00	80	11.0	30	6.0	4.9	3	5.00	101652	101717	101703	101693
7	1.00	80	11.0	30	7.0	5.5	3	6.00	101656	101718		
8	1.25	90	12.5	35	8.0	6.2	3	6.80	101663	101721	101705	101694
9	1.25	90	12.5	35	9.0	7.0	3	7.80	101668			
10	1.50	100	14.0	39	10.0	8.0	3	8.50	101612	101707	101696	101688







N460-3		
N460V-3	 V	
N460TN-3	 TiN	
N460TC-3	 TiCN	

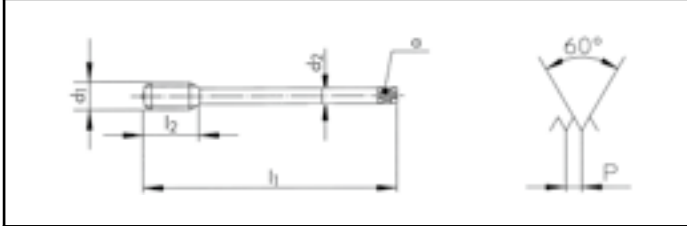

N460-3	N460V-3	N460TN-3	N460TC-3
--------	---------	----------	----------











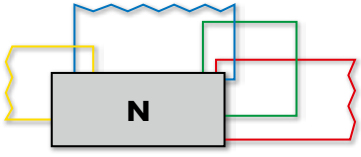









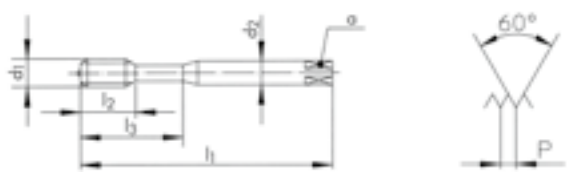



			
---	--	---	---

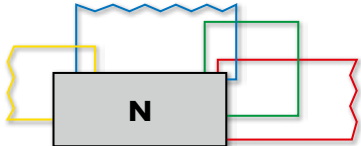

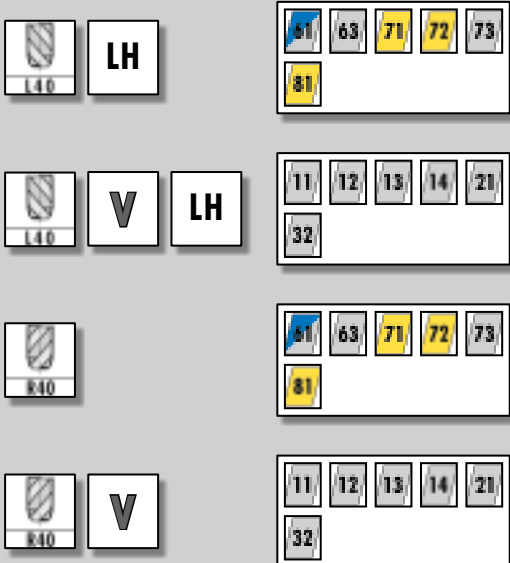

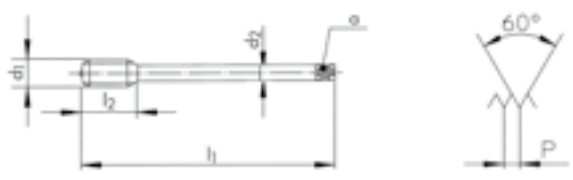





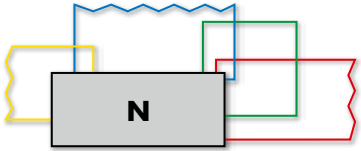











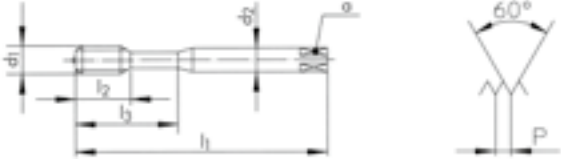

			
ISO 2 6H	ISO 2 6H	ISO 2 6H	ISO 2 6H









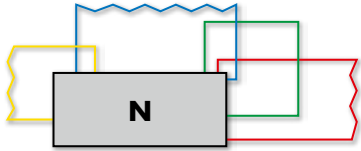

Ø d ₁ M	P mm	l ₁ mm	l ₂ mm	d ₂ mm	α mm			ID	ID	ID	ID
5	0.80	70	9.0	3.5	2.7	3	4.20	102410	102489	160682	
6	1.00	80	11.0	4.5	3.4	3	5.00	102411	102491	152850	
8	1.25	90	12.5	6.0	4.9	3	6.80	102412	102492	152849	
10	1.50	100	14.0	7.0	5.5	3	8.50	102351	102461	150242	158687
12	1.75	110	14.0	9.0	7.0	3	10.20	102359	102465	102449	102438
14	2.00	110	14.0	11.0	9.0	3	12.00	102369	102468	102451	111615
16	2.00	110	18.0	12.0	9.0	3	14.00	102376	102471	102453	102440
18	2.50	125	21.0	14.0	11.0	3	15.50	102383	102473		
20	2.50	140	24.0	16.0	12.0	4	17.50	102389	102475	102454	143280
22	2.50	140	24.0	18.0	14.5	4	19.50	102394	102477		
24	3.00	160	27.0	18.0	14.5	4	21.00	102398	102480	143119	150018
27	3.00	160	27.0	20.0	16.0	4	24.00	175423	102481		
30	3.50	180	30.0	22.0	18.0	4	26.50	150246	102482		
33	3.50	180	33.0	25.0	20.0	4	29.50	167621	102483		
36	4.00	200	36.0	28.0	22.0	5	32.00	143914	102484		
39	4.00	200	40.0	32.0	24.0	5	35.00	175424	102485		
42	4.50	200	40.0	32.0	24.0	5	37.50	169122	102486		
45	4.50	220	44.0	36.0	29.0	5	40.50		102487		
48	5.00	250	48.0	36.0	29.0	5	43.00		102488		
52	5.00	250	52.0	40.0	32.0	5	47.00		110228		
56	5.50	280	56.0	45.0	35.0	6	50.50		102490		
64	6.00	315	64.0	50.0	39.0	6	58.00		143805		





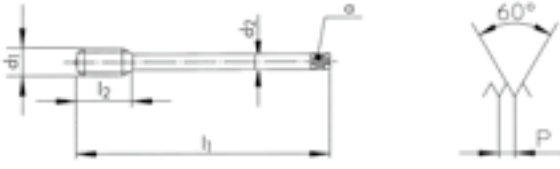





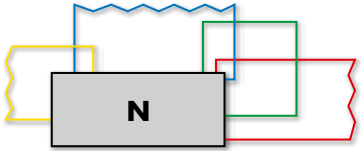



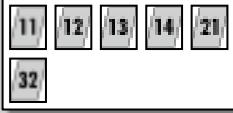

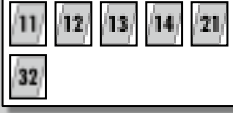

									N360-3 LH	N360V-3 LH	N360-3	N360V-3
												
N360-3 LH		LH										
N360V-3 LH		V LH										
N360-3												
N360V-3		V										
												
												
Ø d ₁ M	P mm	l ₁ mm	l ₂ mm	l ₃ mm	d ₂ mm	a mm		6H → ←	ID	ID	ID ^{6H} + mm	ID ^{6H} + mm
2	0.40	45	7.0		2.8	2.1	2	1.60			101617 0.019	146000 0.019
2.5	0.45	50	9.0		2.8	2.1	2	2.05			101621 0.020	143294 0.020
3	0.50	56	5.5	18	3.5	2.7	3	2.50	101627	146811	101625 0.020	104816 0.020
3.5	0.60	56	6.5	20	4.0	3.0	3	2.95			101629 0.021	125829 0.021
4	0.70	63	7.5	21	4.5	3.4	3	3.30	101637	162540	101634 0.022	104817 0.022
5	0.80	70	9.0	25	6.0	4.9	3	4.20	101646	144003	101643 0.024	104818 0.024
6	1.00	80	11.0	30	6.0	4.9	3	5.00	101654	144004	101669 0.026	104819 0.026
8	1.25	90	12.5	35	8.0	6.2	3	6.80	101666	143925	101662 0.028	104820 0.028
10	1.50	100	14.0	39	10.0	8.0	3	8.50	101615	143587	101611 0.032	104821 0.032

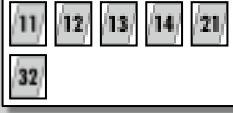
								N460-3 LH	N460V-3 LH	N460-3	N460V-3		
													
													
													
													
$\varnothing d_1$ M	P mm	l_1 mm	l_2 mm	d_2 mm	α mm		$6H$ $\rightarrow \leftarrow$	ID	ID	ID	$6H$ + mm	ID	$6H$ + mm
12	1.75	110	14.0	9.0	7.0	3	10.20	102362	146354	102358	0.034	143602	0.034
14	2.00	110	14.0	11.0	9.0	3	12.00			102368	0.038	144712	0.038
16	2.00	110	18.0	12.0	9.0	3	14.00	102378	143439	102375	0.038	150197	0.038
20	2.50	140	24.0	16.0	12.0	4	17.50	102390	146564	102388	0.042	145420	0.042



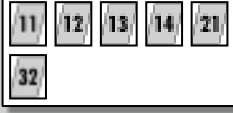
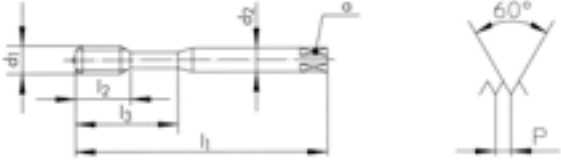





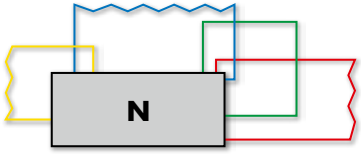

										N360-3	N360-3	N360V-3	N360-3	
														
N360-3  										   				
N360V-3   										   				
										   				
Ø d ₁ M	P mm	l ₁ mm	l ₂ mm	l ₃ mm	d ₂ mm	a mm			ID	ID	6H + mm	ID	6H + mm	ID
3	0.50	56	5.5	18	3.5	2.7	3	2.50	101624	101628	0.036	144311	0.036	160847
4	0.70	63	7.5	21	4.5	3.4	3	3.30	101633	101638	0.041	144192	0.041	101636
5	0.80	70	9.0	25	6.0	4.9	3	4.20	101642	101647	0.044	143208	0.044	101645
6	1.00	80	11.0	30	6.0	4.9	3	5.00	101651	101655	0.050	146709	0.050	101653
8	1.25	90	12.5	35	8.0	6.2	3	△ 6.80	101661	101667	0.052	146267	0.052	101664
10	1.50	100	14.0	39	10.0	8.0	3	8.50	101610	101616	0.060	142547	0.060	101613

△ ISO 1 4H = 

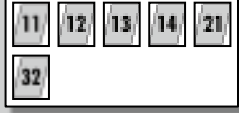
									N460-3	N460-3	N460V-3	N460-3		
														
N460-3														
N460V-3	 V													
														
														
$\varnothing d_1$ M	P mm	l_1 mm	l_2 mm	d_2 mm	a mm				ID	ID	^{6H} + mm	ID	^{6H} + mm	ID
12	1.75	110	14.0	9.0	7.0	3	10.20		* 124987	102363	0.066	142532	0.066	102360
16	2.00	110	18.0	12.0	9.0	3	14.00			102379	0.072	144956	0.072	102377

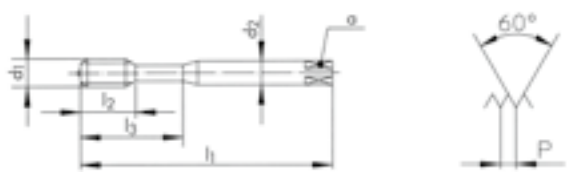
									N360-5	N360V-5	N361-3	N362V-3
												
N360-5												
N360V-5	 V											
N361-3	 											
N362V-3	  V											
												
												
Ø d ₁ M	P mm	l ₁ mm	l ₂ mm	l ₃ mm	d ₂ mm	a mm			ID	ID	ID	ID
2	0.40	45	7.0		2.8	2.1	2	1.60	158079	150058		
3	0.50	56	5.5	18	3.5	2.7	3	2.50	104809	142646	101735	
4	0.70	63	7.5	21	4.5	3.4	3	3.30	104810	142647	101736	101741
5	0.80	70	9.0	25	6.0	4.9	3	4.20	104811	142648	101737	101742
6	1.00	80	11.0	30	6.0	4.9	3	5.00	104812	142649	101738	101743
8	1.25	90	12.5	35	8.0	6.2	3	6.80	104813	142650	101739	101744
10	1.50	100	14.0	39	10.0	8.0	3	8.50	104814	124899	101734	101740

								N460-5	N460V-5	N461-3	N462V-3
N460-5											
N460V-5	V										
N461-3											
N462V-3	V										
$\varnothing d_1$ M	P mm	l_1 mm	l_2 mm	d_2 mm	α mm			ID	ID	ID	ID
12	1.75	110	14.0	9.0	7.0	3	10.20	104815	142651	102506	102512
14	2.00	110	14.0	11.0	9.0	3	12.00			* 102507	102513
16	2.00	110	18.0	12.0	9.0	3	14.00			* 102508	102514
18	2.50	125	21.0	14.0	11.0	3	15.50			* 111614	102515
20	2.50	140	24.0	16.0	12.0	4	17.50				102516
24	3.00	160	27.0	18.0	14.5	4	21.00				102517
27	3.00	160	27.0	20.0	16.0	4	24.00				159244
30	3.50	180	30.0	22.0	18.0	4	26.50				143090

										N520-4	N520V-4	N520TN-4	
													
N520-4													
N520V-4	 V												
N520TN-4	 TiN												
													
													
$\varnothing d_1$ M	P mm	l_1 mm	l_2 mm	l_3 mm	d_2 mm	a mm				ID	ID	ID	
2.5	0.45	100	10.0		2.8	2.1	3	2.05		102594	142623		
3	0.50	112	12.0	18	3.5	2.7	3	2.50		102595	143399	162790	
4	0.70	112	14.0	21	4.5	3.4	3	3.30		102596	143400	146837	
5	0.80	125	15.0	25	6.0	4.9	3	4.20		102597	142654	150113	
6	1.00	125	17.0	30	6.0	4.9	3	5.00		102598	143137	148821	

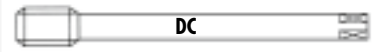

									N620-4	N620V-4	N620TN-4											
N620-4		<table border="1"> <tr> <td>81</td> <td>63</td> <td>71</td> <td>72</td> <td>73</td> </tr> <tr> <td>81</td> <td colspan="4"></td> </tr> </table>							81	63	71	72	73	81								
81	63	71	72	73																		
81																						
N620V-4	V	<table border="1"> <tr> <td>11</td> <td>12</td> <td>13</td> <td>14</td> <td>21</td> </tr> <tr> <td>32</td> <td colspan="4"></td> </tr> </table>							11	12	13	14	21	32								
11	12	13	14	21																		
32																						
N620TN-4	TiN	<table border="1"> <tr> <td>11</td> <td>12</td> <td>13</td> <td>14</td> <td>21</td> </tr> <tr> <td>31</td> <td>32</td> <td>73</td> <td>74</td> <td></td> </tr> </table>							11	12	13	14	21	31	32	73	74					
11	12	13	14	21																		
31	32	73	74																			
$\varnothing d_1$ M	P mm	l_1 mm	l_2 mm	d_2 mm	a mm				ID	ID	ID											
4	0.70	112	14.0	2.8	2.1	3		3.30	102619	142582	146442											
5	0.80	125	15.0	3.5	2.7	3		4.20	102620	142657	146443											
6	1.00	125	17.0	4.5	3.4	3		5.00	102621	142658	144591											
8	1.25	140	20.0	6.0	4.9	3		6.80	102622	143401	146262											
10	1.50	160	22.0	7.0	5.5	3		8.50	102614	142660	146849											
12	1.75	180	24.0	9.0	7.0	3		10.20	102615	143127	146295											
14	2.00	180	28.0	11.0	9.0	3		12.00	102616	151905												
16	2.00	200	30.0	12.0	9.0	3		14.00	102617	143106	143574											
20	2.50	224	36.0	16.0	12.0	3		17.50	102618	143596												



										N560-3	N560V-3	N560TN-3	
N560-3													
N560V-3	V												
N560TN-3	TiN												
Ø d ₁ M	P mm	l ₁ mm	l ₂ mm	l ₃ mm	d ₂ mm	a mm				ID	ID	ID	
2.5	0.45	100	9.0		2.8	2.1	2	2.05		102600	102607		
3	0.50	112	5.5	18	3.5	2.7	3	2.50		102601	102608	142663	
4	0.70	112	7.5	21	4.5	3.4	3	3.30		102602	102609	142664	
5	0.80	125	9.0	25	6.0	4.9	3	4.20		102603	102610	142665	
6	1.00	125	11.0	30	6.0	4.9	3	5.00		102604	102611	142666	
8	1.25	140	12.5	35	8.0	6.2	3	6.80		102605	102612	142667	
10	1.50	160	14.0	39	10.0	8.0	3	8.50		102599	102606	142668	

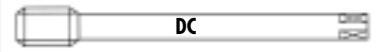









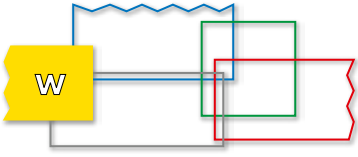











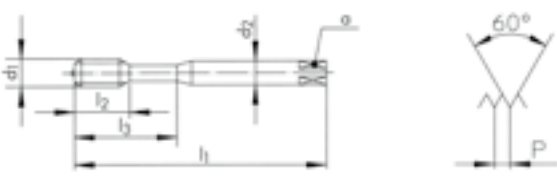











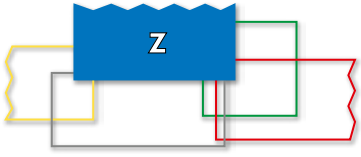









									N660-3	N660V-3	N660TN-3	
N660-3												
N660V-3	V											
N660TN-3	TiN											
$\varnothing d_1$ M	P mm	l_1 mm	l_2 mm	d_2 mm	a mm				ID	ID	ID	
6	1.00	125	11.0	4.5	3.4	3		5.00	162792	115657		
8	1.25	140	12.5	6.0	4.9	3		6.80	162793	115544		
10	1.50	160	14.0	7.0	5.5	3		8.50	162794	135539	173484	
12	1.75	180	14.0	9.0	7.0	3		10.20	102623	102626	142669	
14	2.00	180	14.0	11.0	9.0	3		12.00	162253	147500		
16	2.00	200	18.0	12.0	9.0	3		14.00	102624	102627	142670	
20	2.50	224	24.0	16.0	12.0	4		17.50	102625	102628		

									W320-4	W420-4	W320DL-4	W420DL-4	
W320-4		71 72 81											
W420-4		71 72 81											
W320DL-4		DL	71 72 81							NEW			
W420DL-4		DL	71 72 81							NEW			
$\varnothing d_1$ M	P mm	l_1 mm	l_2 mm	l_3 mm	d_2 mm	a mm			ID	ID	ID	ID	
*2	0.40	45	8.0		2.8	2.1	2	1.60	104612		176688		
2.5	0.45	50	10.0		2.8	2.1	2	2.05	104613		176689		
2.6	0.45	50	10.0		2.8	2.1	2	2.15	* 104614				
3	0.50	56	12.0	18	3.5	2.7	2	2.50	104615		176690		
3.5	0.60	56	13.0	20	4.0	3.0	2	2.90	* 104616				
4	0.70	63	14.0	21	4.5	3.4	2	3.30	104617		176691		
5	0.80	70	15.0	25	6.0	4.9	2	4.20	104618		176354		
6	1.00	80	17.0	30	6.0	4.9	2	5.00	104619		175590		
8	1.25	90	20.0		6.0	4.9	2	6.80		104636		176692	
10	1.50	100	22.0		7.0	5.5	2	8.50		104632		176693	
12	1.75	110	24.0		9.0	7.0	3	10.20		104633		176694	
16	2.00	110	30.0		12.0	9.0	3	14.00		104634		176695	

* W320-3
* W320DL-3



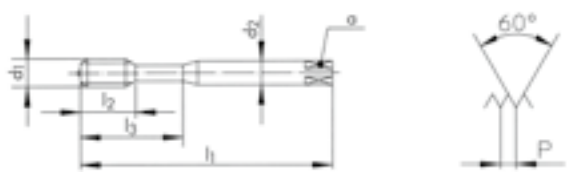







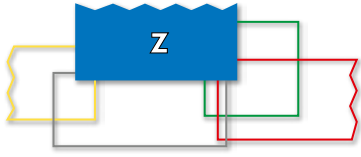



















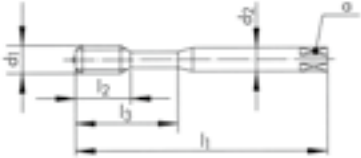

										W360-3	W460-3	W360DL-3	W460DL-3
W360-3													
W460-3													
W360DL-3		DL				 NEW							
W460DL-3		DL				 NEW							
										   			
										   			
Ø d ₁ M	P mm	l ₁ mm	l ₂ mm	l ₃ mm	d ₂ mm	a mm			ID	ID	ID	ID	
2	0.40	45	7.0		2.8	2.1	2	1.60	104625		176719		
2.5	0.45	50	9.0		2.8	2.1	2	2.05	104626		176720		
3	0.50	56	5.5	18	3.5	2.7	2	2.50	104627		176721		
4	0.70	63	7.5	21	4.5	3.4	2	3.30	104628		176722		
5	0.80	70	9.0	25	6.0	4.9	2	4.20	104629		176723		
6	1.00	80	11.0	30	6.0	4.9	2	5.00	104630		176355		
8	1.25	90	12.5	35	8.0	6.2	2	6.80	104631		176724		
10	1.50	100	14.0	39	10.0	8.0	2	8.50	104624		176725		
12	1.75	110	14.0		9.0	7.0	3	10.20		104640		176726	
16	2.00	110	18.0		12.0	9.0	3	14.00		104641		176727	

									Z320V-4	Z420V-4	Z320VS-4	Z420VS-4					
																	
Z320V-4		V	21 22 23 41 42 51														
Z420V-4		V	21 22 23 41 42 51														
Z320VS-4		VS	21 22 23 24 51 51														
Z420VS-4		VS	21 22 23 24 51 51														
																	
Ø d ₁ M	P mm	l ₁ mm	l ₂ mm	l ₃ mm	d ₂ mm	a mm			ID	ID	ID	ID					
*1.6	0.35	40	8.0		2.5	2.1	2	1.25	142671								
*2	0.40	45	8.0		2.8	2.1	2	1.60	111613								
2.5	0.45	50	10.0		2.8	2.1	3	2.05	111455		143683						
2.6	0.45	50	10.0		2.8	2.1	3	2.15	142672								
3	0.50	56	12.0	18	3.5	2.7	3	2.50	104669		104830						
4	0.70	63	14.0	21	4.5	3.4	3	3.30	104670		104831						
5	0.80	70	15.0	25	6.0	4.9	3	4.20	104671		104832						
6	1.00	80	17.0	30	6.0	4.9	3	5.00	104672		104833						
8	1.25	90	20.0	35	8.0	6.2	3	6.80	104673		104834						
10	1.50	100	22.0	39	10.0	8.0	3	8.50	104668		104835						
12	1.75	110	24.0		9.0	7.0	3	10.20		104723		104836					
14	2.00	110	28.0		11.0	9.0	3	12.00		142673		143684					
16	2.00	110	30.0		12.0	9.0	3	14.00		105068		111569					
18	2.50	125	33.0		14.0	11.0	4	15.50		142674							
20	2.50	140	36.0		16.0	12.0	4	17.50		105069		111570					
22	2.50	140	36.0		18.0	14.5	4	19.50		146003							
24	3.00	160	39.0		18.0	14.5	4	21.00		142675							
30	3.50	180	45.0		22.0	18.0	4	26.50		142676							

* Z320V-3



										Z360V-3	Z362V-3	Z462V-3		
Z360V-3														
Z362V-3														
Z462V-3														
 														
														
Ø d ₁ M	P mm	l ₁ mm	l ₂ mm	l ₃ mm	d ₂ mm	a mm				ID	ID	ID		
2	0.40	45	7.0		2.8	2.1	2	1.60		104684				
2.5	0.45	50	9.0		2.8	2.1	2	2.05		104685				
2.6	0.45	50	9.0		2.8	2.1	2	2.15		104686				
3	0.50	56	5.5	18	3.5	2.7	3	2.50		104687				
3.5	0.60	56	6.5	20	4.0	3.0	3	2.90			104688			
4	0.70	63	7.5	21	4.5	3.4	3	3.30			104689			
5	0.80	70	9.0	25	6.0	4.9	3	4.20			104690			
6	1.00	80	11.0	30	6.0	4.9	3	5.00			104691			
8	1.25	90	12.5	35	8.0	6.2	3	6.80			104692			
10	1.50	100	14.0	39	10.0	8.0	3	8.50			104683			
12	1.75	110	14.0		9.0	7.0	3	10.20				104742		
14	2.00	110	14.0		11.0	9.0	3	12.00				104743		
16	2.00	110	18.0		12.0	9.0	3	14.00				104744		
18	2.50	125	21.0		14.0	11.0	3	15.50				104745		
20	2.50	140	24.0		16.0	12.0	3	17.50				104746		
22	2.50	140	24.0		18.0	14.5	3	19.50				104752		
24	3.00	160	27.0		18.0	14.5	4	21.00				104747		
27	3.00	160	27.0		20.0	16.0	4	24.00				104748		
30	3.50	180	30.0		22.0	18.0	4	26.50				104749		
36	4.00	200	36.0		28.0	22.0	4	32.00				104750		
42	4.50	200	40.0		32.0	24.0	4	37.50				104751		

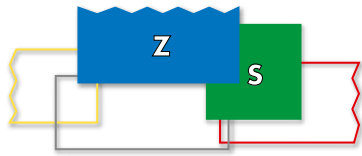

Z362VS-3



Z370VS-3



Z373VS-3

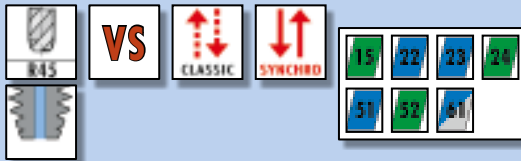

Z362VS-3

Z370VS-3

Z370VS-3

Z373VS-3



PM

PM

PM

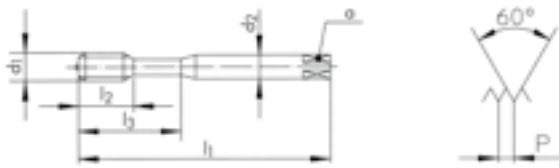

6HX

6HX

4HX

6HX

∅ d ₁ M	P mm	l ₁ mm	l ₂ mm	l ₃ mm	d ₂ mm	a mm		
*3	0.50	56	5.5	18	3.5	2.7	3	2.50
4	0.70	63	7.5	21	4.5	3.4	3	3.30
5	0.80	70	9.0	25	6.0	4.9	3	4.20
6	1.00	80	11.0	30	6.0	4.9	3	5.00
8	1.25	90	12.5	35	8.0	6.2	3	6.80
10	1.50	100	14.0	39	10.0	8.0	3	8.50

ID

111504

111505

111506

111507

111508

111509

* Z360VS-3

∅ d ₁ M	P mm	l ₁ mm	l ₂ mm	l ₃ mm	d ₂ h ₆ mm	a mm		
3	0.50	56	5.5	18	3.5(h9)	2.7	3	2.50
4	0.70	63	7.5	21	4.5(h9)	3.4	3	3.30
5	0.80	70	9.0	25	6.0	4.9	3	4.20
6	1.00	80	11.0	30	6.0	4.9	3	5.00
8	1.25	90	12.5	35	8.0	6.2	3	^Δ 6.80
10	1.50	100	14.0	39	10.0	8.0	3	8.50

ID

ID

ID

162776

165324

165236

162777

165325

165237

162778

165326

165238

162779

165327

165239

162780

165328

165240











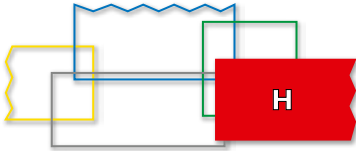

162781

165438

165241

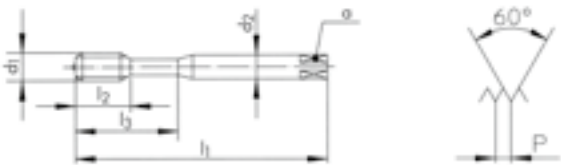
^Δ 4HX = = 6.70

									Z462VS-3	Z470VS-3	Z473VS-3	
<p>Z462VS-3</p>												
<p>Z470VS-3</p>												
<p>Z473VS-3</p>												
∅ d ₁ M	P mm	l ₁ mm	l ₂ mm	d ₂ mm	a mm			ID				
12	1.75	110	14.0	9.0	7.0	4	10.20	111510				
14	2.00	110	14.0	11.0	9.0	4	12.00	* 148169				
16	2.00	110	18.0	12.0	9.0	4	14.00	111511				
20	2.50	140	24.0	16.0	12.0	4	17.50	111512				
24	3.00	160	27.0	18.0	14.5	4	21.00	* 111620				
∅ d ₁ M	P mm	l ₁ mm	l ₂ mm	d ₂ h6 mm	a mm			ID	ID			
12	1.75	110	14.0	*10.0	*8.0	4	10.20	162782	165242			
14	2.00	110	14.0	*12.0	*9.0	4	12.00	162783	* 165243			
16	2.00	110	18.0	12.0	9.0	4	14.00	162784	165244			
18	2.50	125	21.0	14.0	11.0	4	15.50	170643				
20	2.50	140	24.0	16.0	12.0	4	17.50	162785	165234			
22	2.50	140	24.0	16.0	12.0	4	19.50	175190				
24	3.00	160	27.0	16.0	12.0	4	21.00	162786	165235			
* DC 标准 / * DC Norm												

										H320-4	H320TC-4			
H320-4														
H320TC-4	 TiCN													
														
										ISO 2 6H	ISO 2 6H			
$\varnothing d_1$ M	P mm	l_1 mm	l_2 mm	l_3 mm	d_2 mm	a mm			ID	ID				
2	0.40	45	8.0		2.8	2.1	2	1.60	101206	151836				
2.2	0.45	45	9.0		2.8	2.1	2	1.75	111801					
2.5	0.45	50	10.0		2.8	2.1	3	2.05	101207	148603				
3	0.50	56	12.0	18	3.5	2.7	3	2.50	101209	111836				
3.5	0.60	56	13.0	20	4.0	3.0	3	2.90	101210					
4	0.70	63	14.0	21	4.5	3.4	3	3.30	101211	111502				
4.5	0.75	70	15.0	25	6.0	4.9	3	3.75	101212					
5	0.80	70	15.0	25	6.0	4.9	3	4.20	101213	111458				
6	1.00	80	17.0	30	6.0	4.9	3	5.00	101215	111456				
8	1.25	90	20.0	35	8.0	6.2	3	6.80	101218	111453				
10	1.50	100	22.0	39	10.0	8.0	3	8.50	101205	110911				

									H420-4	H420TC-4		
H420-4												
H420TC-4	TiCN											
Ø d ₁ M	P mm	l ₁ mm	l ₂ mm	d ₂ mm	a mm				ID	ID		
12	1.75	110	24.0	9.0	7.0	4		10.20	101275	110912		
14	2.00	110	28.0	11.0	9.0	4		12.00	101277			
16	2.00	110	30.0	12.0	9.0	4		14.00	101279	111612		
18	2.50	125	33.0	14.0	11.0	4		15.50	101281			
20	2.50	140	36.0	16.0	12.0	4		17.50	101284			
24	3.00	160	39.0	18.0	14.5	4		21.00	101286			
27	3.00	160	42.0	20.0	16.0	4		24.00	101287			
30	3.50	180	45.0	22.0	18.0	4		26.50	101288			
36	4.00	200	51.0	28.0	22.0	4		32.00	101289			

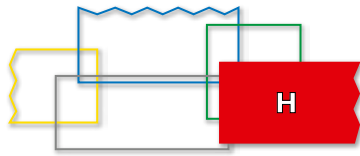

H350-3	H350-3	H350TC-3	
--------	--------	----------	--



H350-3



H350TC-3



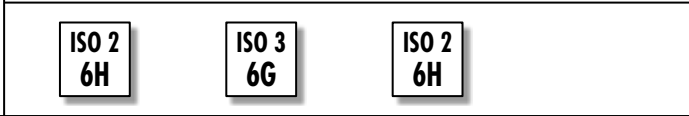
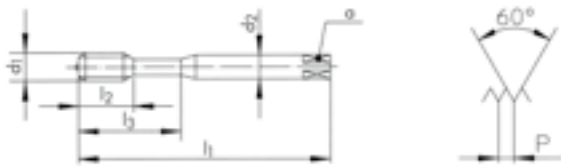

TiCN



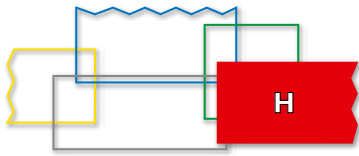

$\varnothing d_1$ M	P mm	l_1 mm	l_2 mm	l_3 mm	d_2 mm	a mm		$6H$ $\rightarrow \leftarrow$
2	0.40	45	7.0		2.8	2.1	2	1.60
2.5	0.45	50	9.0		2.8	2.1	3	2.05
3	0.50	56	5.5	18	3.5	2.7	3	2.50
3.5	0.60	56	6.5	20	4.0	3.0	3	2.90
4	0.70	63	7.5	21	4.5	3.4	3	3.30
4.5	0.75	70	9.0	25	6.0	4.9	3	3.75
5	0.80	70	9.0	25	6.0	4.9	3	4.20
6	1.00	80	11.0	30	6.0	4.9	3	5.00
8	1.25	90	12.5	35	8.0	6.2	3	6.80
10	1.50	100	14.0	39	10.0	8.0	3	8.50

ID	ID $6H$ + mm	ID
101238		146451
101239		144957
101242	101241 0.020	111835
101243		
101245	101244 0.022	111607
101246		
101248	101247 0.024	111610
101251	101250 0.026	111500
101255	101254 0.028	110963
101237	101236 0.032	111454





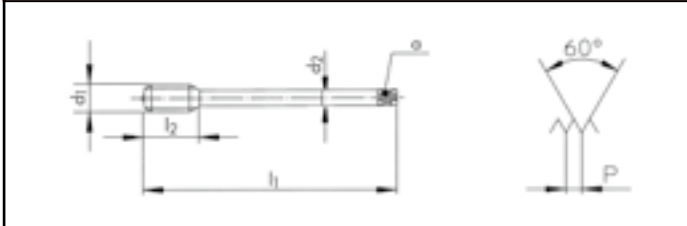

H450-3  

H450TC-3  **TiCN** 

H450-3	H450-3	H450TC-3	
---------------	---------------	-----------------	--



		
ISO 2 6H	ISO 3 6G	ISO 2 6H

Ø d ₁ M	P mm	l ₁ mm	l ₂ mm	d ₂ mm	a mm			ID	ID ^{6H} + mm	ID
12	1.75	110	14.0	9.0	7.0	4	10.20	101305	101304 0.034	111501
14	2.00	110	14.0	11.0	9.0	4	12.00	101307		
16	2.00	110	18.0	12.0	9.0	4	14.00	101309		111605
18	2.50	125	21.0	14.0	11.0	4	15.50	101311		
20	2.50	140	24.0	16.0	12.0	4	17.50	101313		
22	2.50	140	24.0	18.0	14.5	4	19.50	101315		
24	3.00	160	27.0	18.0	14.5	4	21.00	101318		
27	3.00	160	27.0	20.0	16.0	4	24.00	101320		
30	3.50	180	30.0	22.0	18.0	4	26.50	101323		
36	4.00	200	36.0	28.0	22.0	4	32.00	101324		
42	4.50	200	40.0	32.0	24.0	4	37.50	101325		

										S320VS-4	S320VS-4	S420VS-4	
$\varnothing d_1$	P	l_1	l_2	l_3	d_2	α							
M	mm	mm	mm	mm	mm	mm							
3	0.50	56	12.0	18	3.5	2.7	3		2.50	111596	* 165318		
4	0.70	63	14.0	21	4.5	3.4	3		3.30	111597	165319		
5	0.80	70	15.0	25	6.0	4.9	3		4.20	111598	165320		
6	1.00	80	17.0	30	6.0	4.9	3		5.00	111599	165321		
8	1.25	90	20.0	35	8.0	6.2	3		Δ 6.80	111600	165322		
10	1.50	100	22.0	39	10.0	8.0	3		8.50	111601	165323		
12	1.75	110	24.0		9.0	7.0	4		10.20			111602	
14	2.00	110	30.0		11.0	9.0	4		12.50			* 162537	
16	2.00	110	30.0		12.0	9.0	4		14.00			111603	
20	2.50	140	36.0		16.0	12.0	4		17.50			111604	

Δ **4HX** = = 6.70

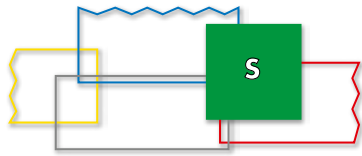

S360VS-3	S460VS-3	SA390-3	SA390-3
----------	----------	---------	---------



S360VS-3 **VS**

S460VS-3 **VS**

aero

SA390-3

6HX	6HX	4HX	6HX

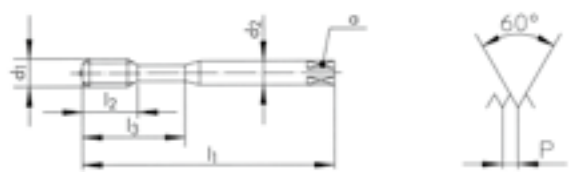

∅ d ₁ M	P mm	l ₁ mm	l ₂ mm	l ₃ mm	d ₂ mm	a mm		
3	0.50	56	5.5	18	3.5	2.7	3	2.50
4	0.70	63	7.5	21	4.5	3.4	3	3.30
5	0.80	70	9.0	25	6.0	4.9	3	4.20
6	1.00	80	11.0	30	6.0	4.9	3	5.00
8	1.25	90	12.5	35	8.0	6.2	3	6.80
10	1.50	100	14.0	39	10.0	8.0	3	8.50
12	1.75	110	14.0		9.0	7.0	4	10.20
14	2.00	110	14.0		11.0	9.0	4	12.00
16	2.00	110	18.0		12.0	9.0	4	14.00
20	2.50	140	24.0		16.0	12.0	4	17.50
24	3.00	160	27.0		18.0	14.5	4	21.00

ID	ID
111513	
111514	
111515	
111516	
111517	
111518	
	111519
	148171
	111520
	111521
	111606

∅ d ₁ M	P mm	l ₁ mm	l ₂ mm	d ₂ mm	a mm		
4	0.70	63	14.0	4.5	3.4	3	3.30
5	0.80	70	15.0	6.0	4.9	3	4.20
6	1.00	80	20.0	6.0	4.9	3	5.00
8	1.25	90	25.0	8.0	6.2	3	Δ 6.80
10	1.50	100	30.0	10.0	8.0	3	8.50
12	1.75	110	35.0	12.0	9.0	4	10.20
14	2.00	110	40.0	16.0	12.0	4	12.00
16	2.00	110	40.0	16.0	12.0	4	14.00

ID	ID
149673	149674
149693	149694
149707	149708
149736	149737
149754	149755
	149775
	* 149792
	* 149816

Δ **4HX** = = 6.70

aero

										SA320-4	SA350-3	TL320VS-4	TL351VS-3																																																																																																																		
<div style="display: flex; justify-content: space-between;"> <div style="width: 45%;"> <p>SA320-4 52 53</p> <p>SA350-3 52 53</p> <p>TL320VS-4 VS 41 42</p> <p>TL351VS-3 VS 41 42</p> </div> <div style="width: 50%; text-align: center;"> </div> </div>																																																																																																																															
										<div style="display: flex; justify-content: space-around;"> <div style="border: 1px solid black; padding: 5px;">4HX</div> <div style="border: 1px solid black; padding: 5px;">4HX</div> <div style="border: 1px solid black; padding: 5px;">4HX</div> <div style="border: 1px solid black; padding: 5px;">4HX</div> </div>																																																																																																																					
<table border="1" style="width: 100%; border-collapse: collapse;"> <thead> <tr> <th>$\varnothing d_1$</th> <th>P</th> <th>l_1</th> <th>l_2</th> <th>l_3</th> <th>d_2</th> <th>a</th> <th></th> <th></th> <th></th> </tr> <tr> <th>M</th> <th>mm</th> <th>mm</th> <th>mm</th> <th>mm</th> <th>mm</th> <th>mm</th> <th></th> <th></th> <th></th> </tr> </thead> <tbody> <tr><td>3</td><td>0.50</td><td>56</td><td>12.0</td><td></td><td>3.5</td><td>2.7</td><td>3</td><td>2.50</td><td>ID</td></tr> <tr><td>4</td><td>0.70</td><td>63</td><td>14.0</td><td></td><td>4.5</td><td>3.4</td><td>3</td><td>3.30</td><td>ID</td></tr> <tr><td>5</td><td>0.80</td><td>70</td><td>15.0</td><td></td><td>6.0</td><td>4.9</td><td>3</td><td>4.20</td><td>ID</td></tr> <tr><td>6</td><td>1.00</td><td>80</td><td>15.0</td><td>23</td><td>6.0</td><td>4.9</td><td>3</td><td>5.00</td><td>ID</td></tr> <tr><td>8</td><td>1.25</td><td>90</td><td>18.0</td><td>29</td><td>8.0</td><td>6.2</td><td>3</td><td>6.70</td><td>ID</td></tr> <tr><td>10</td><td>1.50</td><td>100</td><td>20.0</td><td>33</td><td>10.0</td><td>8.0</td><td>3</td><td>8.50</td><td>ID</td></tr> </tbody> </table>										$\varnothing d_1$	P	l_1	l_2	l_3	d_2	a				M	mm	mm	mm	mm	mm	mm				3	0.50	56	12.0		3.5	2.7	3	2.50	ID	4	0.70	63	14.0		4.5	3.4	3	3.30	ID	5	0.80	70	15.0		6.0	4.9	3	4.20	ID	6	1.00	80	15.0	23	6.0	4.9	3	5.00	ID	8	1.25	90	18.0	29	8.0	6.2	3	6.70	ID	10	1.50	100	20.0	33	10.0	8.0	3	8.50	ID	<table border="1" style="width: 100%; border-collapse: collapse;"> <thead> <tr> <th>ID</th> <th>ID</th> <th>ID</th> <th>ID</th> </tr> </thead> <tbody> <tr><td>147975</td><td>147987</td><td>152006</td><td>152012</td></tr> <tr><td>147976</td><td>147988</td><td>152007</td><td>152013</td></tr> <tr><td>147977</td><td>147989</td><td>152008</td><td>152014</td></tr> <tr><td>147978</td><td>147990</td><td>152009</td><td>152015</td></tr> <tr><td>147979</td><td>147991</td><td>152010</td><td>152016</td></tr> <tr><td>147980</td><td>147992</td><td>152011</td><td>152017</td></tr> </tbody> </table>										ID	ID	ID	ID	147975	147987	152006	152012	147976	147988	152007	152013	147977	147989	152008	152014	147978	147990	152009	152015	147979	147991	152010	152016	147980	147992	152011	152017
$\varnothing d_1$	P	l_1	l_2	l_3	d_2	a																																																																																																																									
M	mm	mm	mm	mm	mm	mm																																																																																																																									
3	0.50	56	12.0		3.5	2.7	3	2.50	ID																																																																																																																						
4	0.70	63	14.0		4.5	3.4	3	3.30	ID																																																																																																																						
5	0.80	70	15.0		6.0	4.9	3	4.20	ID																																																																																																																						
6	1.00	80	15.0	23	6.0	4.9	3	5.00	ID																																																																																																																						
8	1.25	90	18.0	29	8.0	6.2	3	6.70	ID																																																																																																																						
10	1.50	100	20.0	33	10.0	8.0	3	8.50	ID																																																																																																																						
ID	ID	ID	ID																																																																																																																												
147975	147987	152006	152012																																																																																																																												
147976	147988	152007	152013																																																																																																																												
147977	147989	152008	152014																																																																																																																												
147978	147990	152009	152015																																																																																																																												
147979	147991	152010	152016																																																																																																																												
147980	147992	152011	152017																																																																																																																												
										<div style="display: flex; justify-content: space-around;"> <div style="border: 1px solid black; padding: 5px;">6HX</div> <div style="border: 1px solid black; padding: 5px;">6HX</div> <div style="border: 1px solid black; padding: 5px;">6HX</div> <div style="border: 1px solid black; padding: 5px;">6HX</div> </div>																																																																																																																					
<table border="1" style="width: 100%; border-collapse: collapse;"> <thead> <tr> <th>$\varnothing d_1$</th> <th>P</th> <th>l_1</th> <th>l_2</th> <th>l_3</th> <th>d_2</th> <th>a</th> <th></th> <th></th> <th></th> </tr> <tr> <th>M</th> <th>mm</th> <th>mm</th> <th>mm</th> <th>mm</th> <th>mm</th> <th>mm</th> <th></th> <th></th> <th></th> </tr> </thead> <tbody> <tr><td>3</td><td>0.50</td><td>56</td><td>12.0</td><td></td><td>3.5</td><td>2.7</td><td>3</td><td>2.50</td><td>ID</td></tr> <tr><td>4</td><td>0.70</td><td>63</td><td>14.0</td><td></td><td>4.5</td><td>3.4</td><td>3</td><td>3.30</td><td>ID</td></tr> <tr><td>5</td><td>0.80</td><td>70</td><td>15.0</td><td></td><td>6.0</td><td>4.9</td><td>3</td><td>4.20</td><td>ID</td></tr> <tr><td>6</td><td>1.00</td><td>80</td><td>15.0</td><td>23</td><td>6.0</td><td>4.9</td><td>3</td><td>5.00</td><td>ID</td></tr> <tr><td>8</td><td>1.25</td><td>90</td><td>18.0</td><td>29</td><td>8.0</td><td>6.2</td><td>3</td><td>6.80</td><td>ID</td></tr> <tr><td>10</td><td>1.50</td><td>100</td><td>20.0</td><td>33</td><td>10.0</td><td>8.0</td><td>3</td><td>8.50</td><td>ID</td></tr> </tbody> </table>										$\varnothing d_1$	P	l_1	l_2	l_3	d_2	a				M	mm	mm	mm	mm	mm	mm				3	0.50	56	12.0		3.5	2.7	3	2.50	ID	4	0.70	63	14.0		4.5	3.4	3	3.30	ID	5	0.80	70	15.0		6.0	4.9	3	4.20	ID	6	1.00	80	15.0	23	6.0	4.9	3	5.00	ID	8	1.25	90	18.0	29	8.0	6.2	3	6.80	ID	10	1.50	100	20.0	33	10.0	8.0	3	8.50	ID	<table border="1" style="width: 100%; border-collapse: collapse;"> <thead> <tr> <th>ID</th> <th>ID</th> <th>ID</th> <th>ID</th> </tr> </thead> <tbody> <tr><td>147981</td><td>147993</td><td>148001</td><td>148000</td></tr> <tr><td>147982</td><td>147994</td><td>148003</td><td>148002</td></tr> <tr><td>147983</td><td>147995</td><td>148007</td><td>148006</td></tr> <tr><td>147984</td><td>147996</td><td>148011</td><td>148010</td></tr> <tr><td>147985</td><td>147997</td><td>148020</td><td>148018</td></tr> <tr><td>147986</td><td>147998</td><td>148027</td><td>148025</td></tr> </tbody> </table>										ID	ID	ID	ID	147981	147993	148001	148000	147982	147994	148003	148002	147983	147995	148007	148006	147984	147996	148011	148010	147985	147997	148020	148018	147986	147998	148027	148025
$\varnothing d_1$	P	l_1	l_2	l_3	d_2	a																																																																																																																									
M	mm	mm	mm	mm	mm	mm																																																																																																																									
3	0.50	56	12.0		3.5	2.7	3	2.50	ID																																																																																																																						
4	0.70	63	14.0		4.5	3.4	3	3.30	ID																																																																																																																						
5	0.80	70	15.0		6.0	4.9	3	4.20	ID																																																																																																																						
6	1.00	80	15.0	23	6.0	4.9	3	5.00	ID																																																																																																																						
8	1.25	90	18.0	29	8.0	6.2	3	6.80	ID																																																																																																																						
10	1.50	100	20.0	33	10.0	8.0	3	8.50	ID																																																																																																																						
ID	ID	ID	ID																																																																																																																												
147981	147993	148001	148000																																																																																																																												
147982	147994	148003	148002																																																																																																																												
147983	147995	148007	148006																																																																																																																												
147984	147996	148011	148010																																																																																																																												
147985	147997	148020	148018																																																																																																																												
147986	147998	148027	148025																																																																																																																												

aero

SA420-4

SA450-3

TL420VS-4

TL451VS-3



SA420-4



SA450-3



TL420VS-4



VS

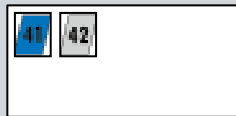

TL451VS-3



VS

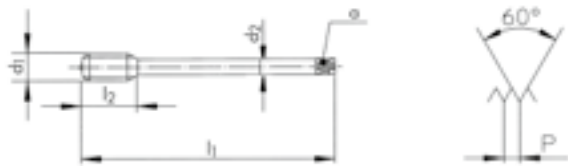

$\varnothing d_1$ M	P mm	l_1 mm	l_2 mm	d_2 mm	a mm		
12	1.75	110	24.0	9.0	7.0	4	10.20
14	2.00	110	28.0	11.0	9.0	4	12.00
16	2.00	110	30.0	12.0	9.0	4	14.00

ID	ID	ID	ID
148096	152189	152192	152195
* 152187			
* 152188	* 152191		152197



$\varnothing d_1$ M	P mm	l_1 mm	l_2 mm	d_2 mm	a mm		
12	1.75	110	24.0	9.0	7.0	4	10.20
14	2.00	110	28.0	11.0	9.0	4	12.00
16	2.00	110	30.0	12.0	9.0	4	14.00

ID	ID	ID	ID
152198	152201	152204	148028
* 152199	* 152202	* 152205	152207
* 152200	152203	* 152206	148029

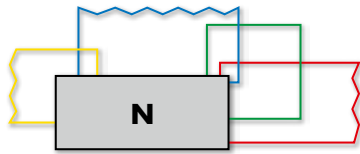

GG350NV-3 GG350TC-3 GG353TC-3 GG550NV-3



GG350NV-3		
GG350TC-3		
GG353TC-3		
GG550NV-3		

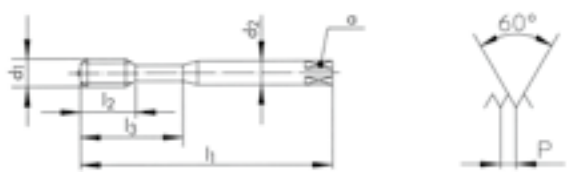
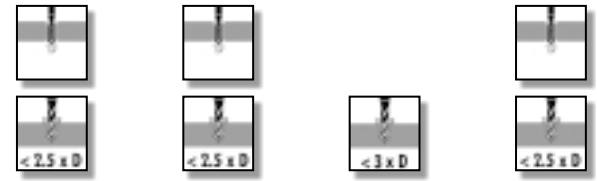

6HX	6HX	6HX	6HX

$\varnothing d_1$ M	P mm	l_1 mm	l_2 mm	l_3 mm	d_2 mm	a mm		
3	0.50	56	12.0	18	3.5	2.7	3	2.50
4	0.70	63	14.0	21	4.5	3.4	3	3.30
5	0.80	70	15.0	25	6.0	4.9	3	4.20
6	1.00	80	17.0	30	6.0	4.9	3	5.00
8	1.25	90	20.0	35	8.0	6.2	4	6.80
10	1.50	100	22.0	39	10.0	8.0	4	8.50

ID	ID
101172	101178
101173	101179
101174	101180
101175	101181
101076	101182
101171	101177

$\varnothing d_1$ M	P mm	l_1 mm	l_2 mm	l_3 mm	d_2 h6 mm	a mm		
5	0.80	70	15.0	25	6.0	4.9	3	4.20
6	1.00	80	17.0	30	6.0	4.9	3	5.00
8	1.25	90	20.0	35	8.0	6.2	4	6.80
10	1.50	100	22.0	39	10.0	8.0	4	8.50

ID
144947
147710
147711
146708

$\varnothing d_1$ M	P mm	l_1 mm	l_2 mm	l_3 mm	d_2 mm	a mm		
4	0.70	112	14.0	21	4.5	3.4	3	3.30
5	0.80	125	15.0	25	6.0	4.9	3	4.20
6	1.00	125	17.0	30	6.0	4.9	3	5.00

ID
101196
101197
101198

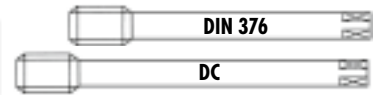

									GG450NV-3	GG450TC-3	GG453TC-3	GG650NV-3
GG450NV-3												
GG450TC-3												
GG453TC-3												
GG650NV-3												
$\varnothing d_1$ M	P mm	l_1 mm	l_2 mm	d_2 mm	a mm				ID	ID		
8	1.25	90	20.0	6.0	4.9	4		6.80	101189	101194		
10	1.50	100	22.0	7.0	5.5	4		8.50	101183	101195		
12	1.75	110	24.0	9.0	7.0	4		10.20	101184	101190		
14	2.00	110	28.0	11.0	9.0	4		12.00	101185	101191		
16	2.00	110	30.0	12.0	9.0	4		14.00	101186	101192		
20	2.50	140	36.0	16.0	12.0	4		17.50	101187	101193		
24	3.00	160	39.0	18.0	14.5	4		21.00	101188			
$\varnothing d_1$ M	P mm	l_1 mm	l_2 mm	d_2 h6 mm	a mm				ID			
12	1.75	110	24.0	*10.0	*8.0	4		10.20	146707			
16	2.00	110	30.0	12.0	9.0	4		14.00	162796			
									* DC 标准 / * DC Norm			
$\varnothing d_1$ M	P mm	l_1 mm	l_2 mm	d_2 mm	a mm				ID			
8	1.25	140	20.0	6.0	4.9	4		6.80	101203			
10	1.50	160	22.0	7.0	5.5	4		8.50	101199			
12	1.75	180	24.0	9.0	7.0	4		10.20	101200			
16	2.00	200	30.0	12.0	9.0	4		14.00	101201			
20	2.50	224	36.0	16.0	12.0	4		17.50	101202			



只适用于刚性攻丝
Only for rigid tapping

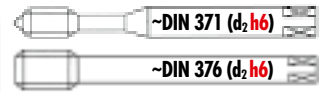

RTS Rigid Tapping Synchro

RTS320VS-4 RTS420VS-4 RTS323VS-4 RTS423VS-4

RTS320VS-4

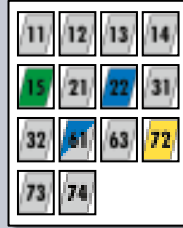

RTS420VS-4



RTS323VS-4

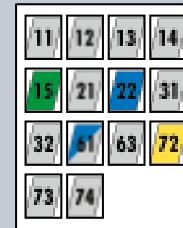

RTS423VS-4

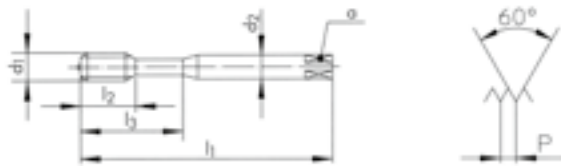

∅ d ₁ M	P mm	l ₁ mm	l ₂ mm	l ₃ mm	d ₂ h ₆ mm	α mm	→ ←	→ ←
*2	0.40	45	8.0		2.8(h9)	2.1	2	1.60
2.5	0.45	50	10.0		2.8(h9)	2.1	3	2.05
3	0.50	56	5.5	18	3.5(h9)	2.7	3	2.50
4	0.70	63	7.5	21	4.5(h9)	3.4	3	3.30
5	0.80	70	9.0	25	6.0	4.9	3	4.20
6	1.00	80	11.0	30	6.0	4.9	3	5.00
8	1.25	90	12.5	35	8.0	6.2	3	6.80
10	1.50	100	14.0	39	10.0	8.0	3	8.50
12	1.75	110	14.0		*10.0	*8.0	3	10.20
14	2.00	110	14.0		*12.0	*9.0	3	12.00
16	2.00	110	18.0		12.0	9.0	3	14.00
20	2.50	140	24.0		16.0	12.0	4	17.50
24	3.00	160	27.0		16.0	12.0	4	21.00

ID	ID	ID	ID
143532			
143534			
150601			
150603			
150605		150606	
150610		150611	
150620		150621	
150635		150636	
	151863		151864
	162535		
	150670		150671
	150679		
	162787		

* DC 标准 / * DC Norm

* RTS320VS-3



应要求
on request



只适用于刚性攻丝
Only for rigid tapping

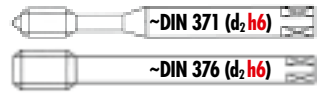

RTS Rigid Tapping Synchro

RTS362VS-3



11	12	13	14
15	21	22	31
32	51	63	72
73	74		

RTS462VS-3



RTS365VS-3



11	12	13	14
15	21	22	31
32	51	63	72
73	74		

RTS465VS-3



RTS362VS-3

RTS462VS-3

RTS365VS-3

RTS465VS-3



6HX

6HX

6HX

6HX

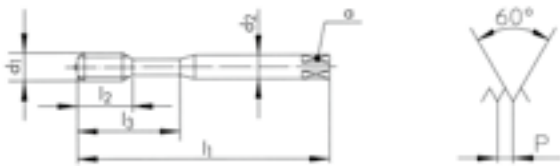

∅ d ₁ M	P mm	l ₁ mm	l ₂ mm	l ₃ mm	d ₂ h6 mm	a mm		
*2	0.40	45	7.0		2.8 (h9)	2.1	3	1.60
*2.5	0.45	50	9.0		2.8 (h9)	2.1	3	2.05
3	0.50	56	5.5	18	3.5 (h9)	2.7	3	2.50
4	0.70	63	7.5	21	4.5 (h9)	3.4	3	3.30
5	0.80	70	9.0	25	6.0	4.9	3	4.20
6	1.00	80	11.0	30	6.0	4.9	3	5.00
8	1.25	90	12.5	35	8.0	6.2	3	6.80
10	1.50	100	14.0	39	10.0	8.0	3	8.50
12	1.75	110	14.0		*10.0	*8.0	3	10.20
14	2.00	110	14.0		*12.0	*9.0	3	12.00
16	2.00	110	18.0		12.0	9.0	3	14.00
20	2.50	140	24.0		16.0	12.0	4	17.50
24	3.00	160	27.0		16.0	12.0	4	21.00

ID

ID

ID

ID

143536

143538

150602

150604

150607

150612

150622

150637

160477

160478

150608

150613

150623

150638

151865

151870

150672

150681

151873

151866

150663

150673

150682

150690

* DC 标准 / * DC Norm

* RTS360VS-3



应要求
on request



只适用于刚性攻丝
Only for rigid tapping



RTS Rigid Tapping Synchro

RTS362VS-5



VS

11	12	13	14
15	21	22	31
32	41	63	72
73	74		

RTS365VS-5



VS

11	12	13	14
15	21	22	31
32	41	63	72
73	74		

RTS362VS-3



VS

11	12	13	14
15	21	22	31
32	41	63	72
73	74		

RTS362VS-5

RTS365VS-5

RTS362VS-3

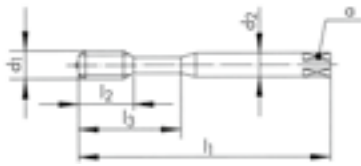

6HX

6HX

6GX

$\varnothing d_1$ M	P mm	l_1 mm	l_2 mm	l_3 mm	d_2 h6 mm	α mm		
3	0.50	56	5.5	18	3.5(h9)	2.7	3	2.50
4	0.70	63	7.5	21	4.5(h9)	3.4	3	3.30
5	0.80	70	9.0	25	6.0	4.9	3	4.20
6	1.00	80	11.0	30	6.0	4.9	3	5.00
8	1.25	90	12.5	35	8.0	6.2	3	6.80
10	1.50	100	14.0	39	10.0	8.0	3	8.50

ID

ID

157648

157650

157652

162791

158074

151803

158076

157821

153286

157823

$\varnothing d_1$ M	P mm	l_1 mm	l_2 mm	l_3 mm	d_2 h6 mm	α mm			6H + mm
3	0.50	56	5.5	18	3.5(h9)	2.7	3	2.50	162797 0.020
4	0.70	63	7.5	21	4.5(h9)	3.4	3	3.35	162798 0.022
5	0.80	70	9.0	25	6.0	4.9	3	4.25	162799 0.024
6	1.00	80	11.0	30	6.0	4.9	3	5.00	162800 0.026
8	1.25	90	12.5	35	8.0	6.2	3	6.80	162801 0.028
10	1.50	100	14.0	39	10.0	8.0	3	8.50	162802 0.032

ID

6H
+ mm

162797 0.020

162798 0.022

162799 0.024

162800 0.026

162801 0.028

162802 0.032



应要求
on request

$\geq \varnothing 6 \text{ mm}$



只适用于刚性攻丝
Only for rigid tapping

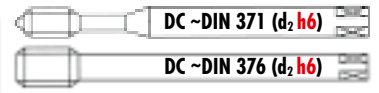

RTS Rigid Tapping Synchro

RTS523VS-4 **VS**

RTS623VS-4 **VS**

RTS565VS-3 **VS**

RTS665VS-3 **VS**

RTS523VS-4	RTS623VS-4	RTS565VS-3	RTS665VS-3
------------	------------	------------	------------

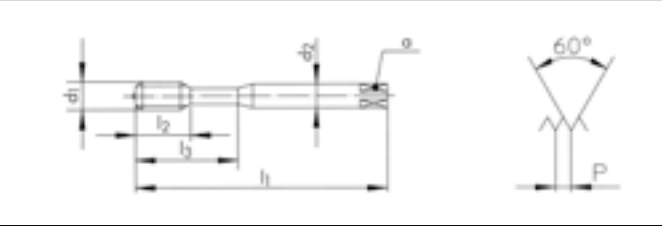

$\varnothing d_1$ M	P mm	l_1 mm	l_2 mm	l_3 mm	$d_2 h_6$ mm	α mm		
5	0.80	125	9.0	25	6.0	4.9	3	4.20
6	1.00	125	11.0	30	6.0	4.9	3	5.00
8	1.25	140	12.5	35	8.0	6.2	3	6.80
10	1.50	160	14.0	39	10.0	8.0	3	8.50
12	1.75	180	14.0		*10.0	*8.0	3	10.20
16	2.00	200	18.0		12.0	9.0	3	14.00

ID	ID
161038	
161041	
161044	
161047	
	161050
	161053

* DC 标准 / * DC Norm

$\varnothing d_1$ M	P mm	l_1 mm	l_2 mm	l_3 mm	$d_2 h_6$ mm	α mm		
6	1.00	125	11.0	30	6.0	4.9	3	5.00
8	1.25	140	12.5	35	8.0	6.2	3	6.80
10	1.50	160	14.0	39	10.0	8.0	3	8.50
12	1.75	180	14.0		*10.0	*8.0	3	10.20
16	2.00	200	18.0		12.0	9.0	3	14.00

ID	ID	
	150614	
	150624	
	150639	
		151867
		150674

* DC 标准 / * DC Norm

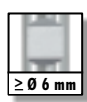

应要求
on request

K

K313TC-3

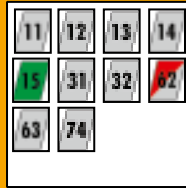

K413TC-3

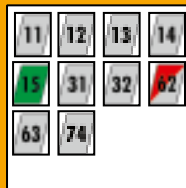

K313TC-3

K413TC-3







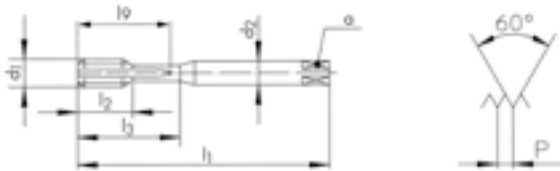



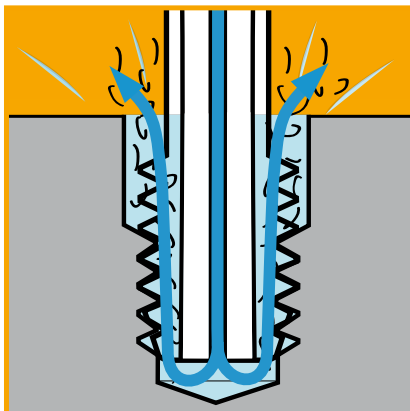





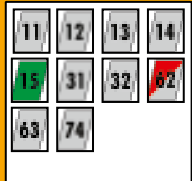





6HX



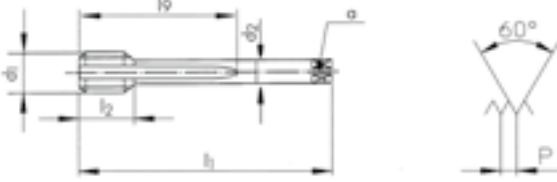

6HX



$\varnothing d_1$ M	P mm	l_1 mm	l_2 mm	l_3 mm	l_9 mm	d_2 mm	a mm	\rightarrow	\leftarrow	ID	ID
6	1.00	80	17.0	30	28.0	6.0	4.9	3	5.00	170766	
8	1.25	90	20.0	35	33.0	8.0	6.2	3	6.80	170769	
10	1.50	100	22.0	39	37.0	10.0	8.0	3	8.50	170772	
12	1.75	110	24.0		42.0	9.0	7.0	3	10.20		165838
14	2.00	110	28.0		49.0	11.0	9.0	3	12.00		170778
16	2.00	110	30.0		56.0	12.0	9.0	4	14.00		170783
20	2.50	140	36.0		70.0	16.0	12.0	5	17.50		170786
24	3.00	160	39.0		84.0	18.0	14.5	5	21.00		170775



K										K613TC-3	K613VS-3		
<p>K613TC-3</p>     <p>>20 bar</p> 											 <p>NEW</p>	 <p>< 4 x D</p>	 <p>< 4 x D</p>
<p>K613VS-3</p>     <p>>20 bar</p> 													
													
													
$\varnothing d_1$ M	P mm	l_1 mm	l_2 mm	l_3 mm	d_2 mm	a mm				ID	ID		
6	1.00	110	17.0	30	4.5	3.4	3	5.00		170646	172699		
8	1.25	110	20.0	40	6.0	4.9	3	6.80		170649	172700		
10	1.50	125	22.0	50	7.0	5.5	3	8.50		170652	172701		
12	1.75	140	24.0	60	9.0	7.0	3	10.20		167982	172702		
14	2.00	140	28.0	70	11.0	9.0	3	12.00		167983			
16	2.00	160	30.0	80	12.0	9.0	4	14.00		167984	170573		
20	2.50	180	36.0	100	16.0	12.0	5	17.50		167985	170576		
24	3.00	200	39.0	120	18.0	14.5	5	21.00		167986	172704		
27	3.00	225	42.0	135	20.0	16.0	5	24.00		167987			
30	3.50	250	45.0	150	22.0	18.0	5	26.50		165542			
33	3.50	280	48.0	165	25.0	20.0	5	29.50		167988			
36	4.00	300	51.0	180	28.0	22.0	6	32.00		167989			
39	4.00	300	55.0	195	32.0	24.0	6	35.00		167990			
42	4.50	355	55.0	210	32.0	24.0	6	37.50		167999			

Vc (m/min)				
	M6 - M10	M12 - M16	M20 - M30	M33 - M42
	32	28	22	18
	30	25	20	15
	24	20	16	12
	15	12	8	6
	35	30	25	20

FS FORMING

FS380VS-5



VS



FS380VS-3



VS



FS380VS-5

FS380VS-3

FS380VS-3

FS380VS-3



6HX

6HX

6HX

6GX

$\varnothing d_1$ M	P mm	l_1 mm	l_2 mm	d_2 mm	a mm	4HX Tol. → ← 6HX
1	0.25	40	3.0	2.5		0.88 + 0.02
1.2	0.25	40	3.6	2.5		1.08 + 0.02
1.4	0.30	40	4.2	2.5		1.25 + 0.02
1.6	0.35	40	4.8	2.5		1.45 + 0.02
1.7	0.35	40	5.1	2.5		1.55 + 0.02
1.8	0.35	40	5.4	2.5		1.65 + 0.02
2	0.40	45	8.0	2.8	2.1	1.80 + 0.02
2.5	0.45	50	10.0	2.8	2.1	2.30 + 0.02
2.6	0.45	50	10.0	2.8	2.1	2.40 + 0.02

ID

ID

ID

ID

6H
+ mm

157171

173452

157172

173455

157173

173458

157174

169779

157175

169782

157175

169785

157176

157180 0.019

157178

157181 0.020

157179

≤ M1.5 4HX

FS FORMING

FS380DL-5



11	12	13	14
21	22	23	24
41	51	61	63
71	72	73	

FS380DL-3



11	12	13	14
21	22	23	24
41	51	61	63
71	72	73	

FS380DL-5 FS380DL-3 FS380DL-3 FS380DL-3



NEW NEW NEW NEW

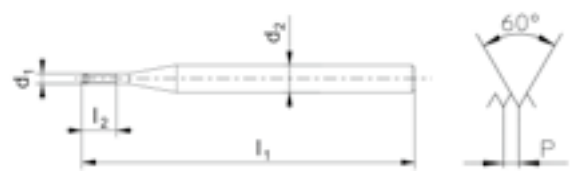

6HX 6HX 6HX 6GX

$\varnothing d_1$ M	P mm	l_1 mm	l_2 mm	d_2 mm	α mm	4HX Tol. 6HX	ID	ID	ID	ID	6H + mm
1	0.25	40	3.0	2.5		0.88 +0.02	172839	173461			
1.2	0.25	40	3.6	2.5		1.08 +0.02	172840	173464			
1.4	0.30	40	4.2	2.5		1.25 +0.02	172841	173467			
1.6	0.35	40	4.8	2.5		1.45 +0.02	170585	170916			
1.7	0.35	40	5.1	2.5		1.55 +0.02		172843			
1.8	0.35	40	5.4	2.5		1.65 +0.02	172842	172844			
2	0.40	45	8.0	2.8	2.1	1.80 +0.02			158814	172849	0.019
2.5	0.45	50	10.0	2.8	2.1	2.30 +0.02			172845	173246	0.020
2.6	0.45	50	10.0	2.8	2.1	2.40 +0.02			172846		

≤ M1.5 4HX

FPS FORMING

FPS380CN-3



CrN



FPS381CN-3



CrN



FPS380VS-3



VS



FPS381VS-3



VS

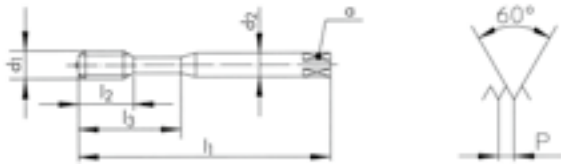

FPS380CN-3

FPS381CN-3

FPS380VS-3

FPS381VS-3



6HX

6HX

6HX

6HX

$\varnothing d_1$ M	P mm	l_1 mm	l_2 mm	l_3 mm	d_2 mm	a mm	$\rightarrow \leftarrow$	Tol.
3	0.50	56	12.0	18	3.5	2.7	2.80	+ 0.03
3.5	0.60	56	13.0	20	4.0	3.0	3.25	+ 0.03
4	0.70	63	14.0	21	4.5	3.4	3.70	+ 0.03
5	0.80	70	15.0	25	6.0	4.9	4.65	+ 0.03
6	1.00	80	17.0	30	6.0	4.9	5.55	+ 0.05
8	1.25	90	20.0	35	8.0	6.2	7.40	+ 0.05
10	1.50	100	22.0	39	10.0	8.0	9.30	+ 0.05

ID

ID

ID

ID

166613	166615	166614	166616
166619	166621	166620	166622
166626	166628	166627	166629
166634	166636	166635	166637
166643	166645	166644	166646
166653	166655	166654	166656
166663	166665	166664	166666

6GX

6GX

$\varnothing d_1$ M	P mm	l_1 mm	l_2 mm	l_3 mm	d_2 mm	a mm	$\rightarrow \leftarrow$	Tol.
3	0.50	56	12.0	18	3.5	2.7	2.80	+ 0.03
3.5	0.60	56	13.0	20	4.0	3.0	3.25	+ 0.03
4	0.70	63	14.0	21	4.5	3.4	3.70	+ 0.03
5	0.80	70	15.0	25	6.0	4.9	4.65	+ 0.03
6	1.00	80	17.0	30	6.0	4.9	5.55	+ 0.05
8	1.25	90	20.0	35	8.0	6.2	7.40	+ 0.05
10	1.50	100	22.0	39	10.0	8.0	9.30	+ 0.05

ID 6H
+ mm

ID 6H
+ mm

166697	0.020	166617	0.020
166687	0.021	166623	0.021
166688	0.022	166630	0.022
166689	0.024	166638	0.024
166686	0.026	166647	0.026
166740	0.028	166657	0.028
166739	0.032	166667	0.032

FPS FORMING

FPS481VS-3



VS



FPS581VS-3



EL

VS



FPS681VS-3



EL

VS



FPS481VS-3



FPS581VS-3



NEW

FPS681VS-3



NEW



< 2.5 x D



< 2.5 x D



< 2.5 x D



2.5 x P



2.5 x P



2.5 x P

6HX

6HX

6HX

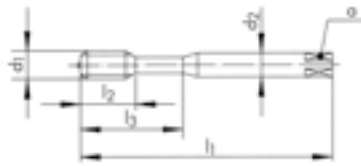

$\varnothing d_1$ M	P mm	l_1 mm	l_2 mm	d_2 mm	a mm	6HX Tol. → ←	ID
12	1.75	110	24.0	9.0	7.0	11.20 + 0.05	166673
14	2.00	110	28.0	11.0	9.0	13.10 + 0.05	166678
16	2.00	110	30.0	12.0	9.0	15.10 + 0.05	166683
20	2.50	140	36.0	16.0	12.0	18.85 + 0.05	168713

$\varnothing d_1$ M	P mm	l_1 mm	l_2 mm	l_3 mm	d_2 mm	a mm	6HX Tol. → ←	ID	ID
3	0.50	100	12.0	18	3.5	2.7	2.80 + 0.03	172824	
4	0.70	125	14.0	21	4.5	3.4	3.70 + 0.03	172826	
5	0.80	140	15.0	25	6.0	4.9	4.65 + 0.03	172828	
6	1.00	160	17.0	30	6.0	4.9	5.55 + 0.05	172830	
8	1.25	180	20.0	35	8.0	6.2	7.40 + 0.05	172832	
10	1.50	200	22.0	39	10.0	8.0	9.30 + 0.05	172834	
12	1.75	224	24.0		9.0	7.0	11.20 + 0.05		172836

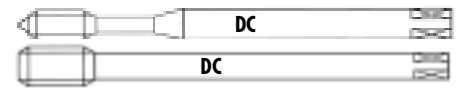
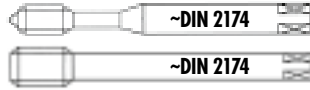

FPS FORMING

FPS384VS-3



FPS484VS-3



FPS584VS-3



FPS684VS-3



FPS384VS-3

FPS484VS-3

FPS584VS-3

FPS684VS-3



6HX

6HX

6HX

6HX

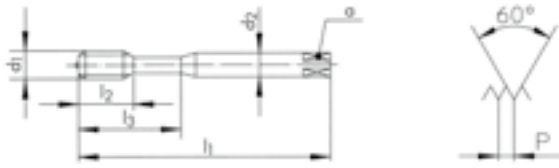

∅ d ₁ M	P mm	l ₁ mm	l ₂ mm	l ₃ mm	d ₂ mm	a mm	6HX Tol. → ←
3	0.50	56	12.0	18	3.5	2.7	2.80 +0.03
4	0.70	63	14.0	21	4.5	3.4	3.70 +0.03
5	0.80	70	15.0	25	6.0	4.9	4.65 +0.03
6	1.00	80	17.0	30	6.0	4.9	5.55 +0.05
8	1.25	90	20.0	35	8.0	6.2	7.40 +0.05
10	1.50	100	22.0	39	10.0	8.0	9.30 +0.05
12	1.75	110	24.0		9.0	7.0	11.20 +0.05
14	2.00	110	28.0		11.0	9.0	13.10 +0.05
16	2.00	110	30.0		12.0	9.0	15.10 +0.05

ID

ID

166737

166738

166640

166650

166660

166670

166675

166680

166685

∅ d ₁ M	P mm	l ₁ mm	l ₂ mm	l ₃ mm	d ₂ mm	a mm	6HX Tol. → ←
3	0.50	100	12.0	18	3.5	2.7	2.80 +0.03
4	0.70	125	14.0	21	4.5	3.4	3.70 +0.03
5	0.80	140	15.0	25	6.0	4.9	4.65 +0.03
6	1.00	160	17.0	30	6.0	4.9	5.55 +0.05
8	1.25	180	20.0	35	8.0	6.2	7.40 +0.05
10	1.50	200	22.0	39	10.0	8.0	9.30 +0.05
12	1.75	224	24.0		9.0	7.0	11.20 +0.05

ID

ID

172763

172766

172769

172772

172775

172778

172781

FAS FORMING

FAS380VS-3



VS

12	13	14	15
21	22	23	24
41	51	61	63

FAS381VS-3



VS

12	13	14	15
21	22	23	24
41	51	61	63

FAS481VS-3



VS

12	13	14	15
21	22	23	24
41	51	61	63

FAS380VS-3



FAS381VS-3



FAS481VS-3

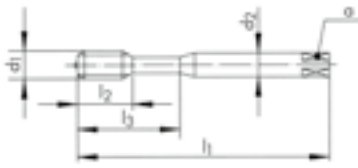

6HX

6HX

6HX

∅ d ₁ M	P mm	l ₁ mm	l ₂ mm	l ₃ mm	d ₂ mm	a mm	6HX Tol. → ←
3	0.50	56	12.0	18	3.5	2.7	2.80 +0.03
3.5	0.60	56	13.0	20	4.0	3.0	3.25 +0.03
4	0.70	63	14.0	21	4.5	3.4	3.70 +0.03
5	0.80	70	15.0	25	6.0	4.9	4.65 +0.03
6	1.00	80	17.0	30	6.0	4.9	5.55 +0.05
8	1.25	90	20.0	35	8.0	6.2	7.40 +0.05
10	1.50	100	22.0	39	10.0	8.0	9.30 +0.05
12	1.75	110	24.0		9.0	7.0	11.20 +0.05
14	2.00	110	28.0		11.0	9.0	13.10 +0.05
16	2.00	110	30.0		12.0	9.0	15.10 +0.05
20	2.50	140	36.0		16.0	12.0	18.85 +0.05

ID

ID

ID

170603
170605
170607
170609
170611
170616
170618

166612
166618
166624
166632
166641
166651
166661

166671
166676
166681
168711

6GX

6GX

∅ d ₁ M	P mm	l ₁ mm	l ₂ mm	l ₃ mm	d ₂ mm	a mm	6HX Tol. → ←
3	0.50	56	12.0	18	3.5	2.7	2.80 +0.03
3.5	0.60	56	13.0	20	4.0	3.0	3.25 +0.03
4	0.70	63	14.0	21	4.5	3.4	3.70 +0.03
5	0.80	70	15.0	25	6.0	4.9	4.65 +0.03
6	1.00	80	17.0	30	6.0	4.9	5.55 +0.05
8	1.25	90	20.0	35	8.0	6.2	7.40 +0.05
10	1.50	100	22.0	39	10.0	8.0	9.30 +0.05
12	1.75	110	24.0		9.0	7.0	11.20 +0.05
14	2.00	110	28.0		11.0	9.0	13.10 +0.05
16	2.00	110	30.0		12.0	9.0	15.10 +0.05

ID

6H
+ mm

ID

6H
+ mm

166703 0.020
* 166704 0.021
166705 0.022
166706 0.024
166707 0.026
166708 0.028
166709 0.032
166710 0.034
166711 0.038
166712 0.038

FAS FORMING

FAS384VS-3



VS

12	13	14	15
21	22	23	24
41	51	61	63

FAS484VS-3



VS

12	13	14	15
21	22	23	24
41	51	61	63

FAS384VS-3

FAS484VS-3

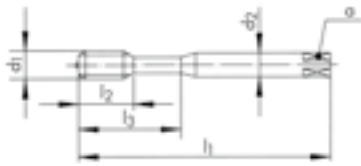

6HX

6HX

$\varnothing d_1$ M	P mm	l_1 mm	l_2 mm	l_3 mm	d_2 mm	a mm	6HX Tol. → ←
3	0.50	56	12.0	18	3.5	2.7	2.80 + 0.03
4	0.70	63	14.0	21	4.5	3.4	3.70 + 0.03
5	0.80	70	15.0	25	6.0	4.9	4.65 + 0.03
6	1.00	80	17.0	30	6.0	4.9	5.55 + 0.05
8	1.25	90	20.0	35	8.0	6.2	7.40 + 0.05
10	1.50	100	22.0	39	10.0	8.0	9.30 + 0.05
12	1.75	110	24.0		9.0	7.0	11.20 + 0.05
14	2.00	110	28.0		11.0	9.0	13.10 + 0.05
16	2.00	110	30.0		12.0	9.0	15.10 + 0.05

ID

ID

166741

166742

166690

166691

166692

166693

166694

* 166695

166696

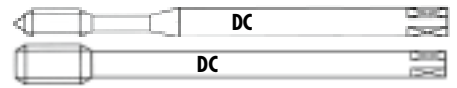

FAS FORMING

FAS581VS-3

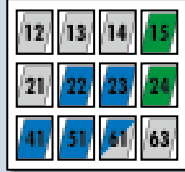

FAS681VS-3



FAS584VS-3

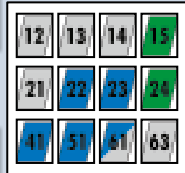

FAS684VS-3

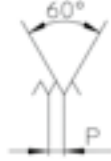
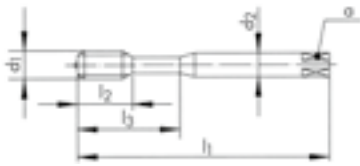

FAS581VS-3

FAS681VS-3

FAS584VS-3

FAS684VS-3



NEW



NEW



NEW



NEW



< 2.5 x D



< 2.5 x D



< 3 x D



< 3 x D



2.5 x P



2.5 x P



2.5 x P



2.5 x P

6HX

6HX

6HX

6HX

Ø d ₁ M	P mm	l ₁ mm	l ₂ mm	l ₃ mm	d ₂ mm	α mm	6HX Tol. → ←
3	0.50	100	12.0	18	3.5	2.7	2.80 + 0.03
4	0.70	125	14.0	21	4.5	3.4	3.70 + 0.03
5	0.80	140	15.0	25	6.0	4.9	4.65 + 0.03
6	1.00	160	17.0	30	6.0	4.9	5.55 + 0.05
8	1.25	180	20.0	35	8.0	6.2	7.40 + 0.05
10	1.50	200	22.0	39	10.0	8.0	9.30 + 0.05
12	1.75	224	24.0		9.0	7.0	11.20 + 0.05

ID

ID

ID

ID

172784

172805

172787

172808

172790

172811

172793

172814

172796

172817

172799











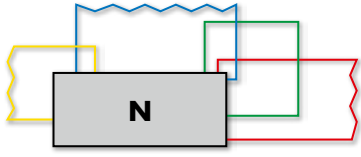

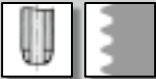
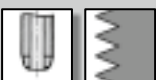
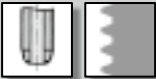
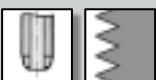





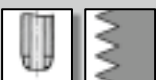

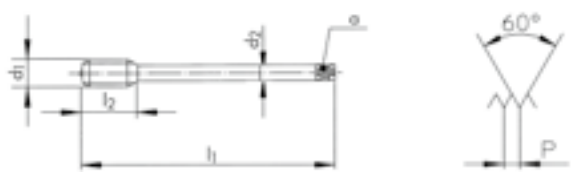

172820

172802

172822



									N1110-1	N1110-2	N1110-3	N1110-S
N1110-1												
N1110-2												
N1110-3												
N1110-S												
											ISO 2 6H	ISO 2 6H
Ø d ₁ M	P mm	l ₁ mm	l ₂ mm	l ₃ mm	d ₂ mm	a mm			ID	ID	ID	ID
1	0.25	40	5.5		2.50	2.10	3	0.75	102744	102844	102917	111015
1.2	0.25	40	5.5		2.50	2.10	3	0.95	102746	102846	102919	111017
1.4	0.30	40	7.0		2.50	2.10	3	1.10	102747	102847	102920	111018
1.6	0.35	40	8.0		2.50	2.10	3	1.25	102749	102849	102922	111020
1.7	0.35	40	8.0		2.50	2.10	3	1.35	102750	102850	102923	111021
1.8	0.35	40	8.0		2.50	2.10	3	1.45	102751	102851	102924	111022
2	0.40	45	8.0		2.80	2.10	3	1.60	102759	102854	102934	111028
2.2	0.45	45	9.5		2.80	2.10	3	1.75	102761	102856	102937	111030
2.5	0.45	45	9.5		2.80	2.10	3	2.05	102763	102858	102941	111032
2.6	0.45	45	9.5		2.80	2.10	3	2.15	102765	102860	102944	111034
3	0.50	48	11.0	18	3.15	2.50	3	2.50	102766	102861	102947	111036
3.5	0.60	50	13.0	20	3.55	2.80	3	2.90	102769	102864	102950	111038
4	0.70	53	13.0	21	4.00	3.15	3	3.30	102771	102866	102956	111042
4.5	0.75	53	13.0	21	4.50	3.55	3	3.75	102775	102869	102959	111044
5	0.80	58	16.0	25	5.00	4.00	3	4.20	102776	102870	102965	111047
6	1.00	66	19.0	30	6.30	5.00	3	5.00	102781	102874	102973	111053
7	1.00	66	19.0	30	7.10	5.60	3	6.00	102786	102876	102978	111055
8	1.25	72	22.0	35	8.00	6.30	3	6.80	102788	102878	102986	111059
9	1.25	72	22.0	36	9.00	7.10	3	7.80	102792	102880	102991	111061
10	1.50	80	24.0	39	10.00	8.00	3	8.50	102752	102852	102931	111026























									N1210-1	N1210-2	N1210-3	N1210-S
									N1210-1			
N1210-2												
N1210-3												
N1210-S												
												
												
$\varnothing d_1$ M	P mm	l_1 mm	l_2 mm	d_2 mm	a mm			ID	ID	ID	ID	
11	1.50	85	22.0	8.0	6.3	3	9.50	103302	103427	103489	111168	
12	1.75	89	24.0	9.0	7.1	3	10.20	103303	103428	103499	111173	
14	2.00	95	24.0	11.2	9.0	3	12.00	103310	103430	103510	111179	
16	2.00	102	32.0	12.5	10.0	3	14.00	103319	103432	103522	111185	
18	2.50	112	30.0	14.0	11.2	3	15.50	103324	103434	103534	111191	
20	2.50	112	37.0	14.0	11.2	3	17.50	103330	103436	103543	111196	
22	2.50	115	32.0	16.0	12.5	3	19.50	103337	103438	103550	125567	
24	3.00	130	45.0	18.0	14.0	4	21.00	103341	103440	103557	111204	
27	3.00	135	45.0	20.0	16.0	4	24.00	103347	103442	103568	111211	
30	3.50	138	48.0	20.0	16.0	4	26.50	103353	103444	103579	111216	
33	3.50	151	51.0	22.4	18.0	4	29.50	103357	103446	103581	111218	
36	4.00	162	57.0	25.0	20.0	4	32.00	103359	103448	103583	111220	

























										N1120-4	N1220-4	N1160-3	N1260-3
N1120-4													
N1220-4												NEW	NEW
N1160-3													
N1260-3													
$\varnothing d_1$	P	l_1	l_2	l_3	d_2	a				ID	ID		
M	mm	mm	mm	mm	mm	mm							
3	0.50	48	11.0	18	3.15	2.50	3	2.50		103068			
4	0.70	53	13.0	21	4.00	3.15	3	3.30		103075			
4.5	0.75	53	13.0	21	4.50	3.55	3	3.75		* 103078			
5	0.80	58	16.0	25	5.00	4.00	3	4.20		103082			
6	1.00	66	19.0	30	6.30	5.00	3	5.00		103090			
8	1.25	72	22.0	35	8.00	6.30	3	6.80		103102			
10	1.50	80	24.0	39	10.00	8.00	3	8.50		103060			
11	1.50	85	22.0		8.00	6.30	3	9.50			* 103661		
12	1.75	89	24.0		9.00	7.10	3	10.20			103670		
14	2.00	95	24.0		11.20	9.00	3	12.00			103680		
16	2.00	102	32.0		12.50	10.00	3	14.00			103690		
$\varnothing d_1$	P	l_1	l_2	l_3	d_2	a				ID	ID		
M	mm	mm	mm	mm	mm	mm							
3	0.50	48	5.5	18	3.15	2.50	3	2.50			103177		
4	0.70	53	7.5	21	4.00	3.15	3	3.30			103178		
5	0.80	58	9.0	25	5.00	4.00	3	4.20			103179		
6	1.00	66	11.0	30	6.30	5.00	3	5.00			103180		
8	1.25	72	12.5	35	8.00	6.30	3	6.80			103181		
10	1.50	80	14.0	39	10.00	8.00	3	8.50			103174		
12	1.75	89	14.0		9.00	7.10	3	10.20				103781	
16	2.00	102	18.0		12.50	10.00	3	14.00				103782	

										NP110-1	NP110-2	NP110-3	NP110-S
										NP110-1 NP210-1			
NP110-2 NP210-2													
NP110-3 NP210-3													
NP110-S NP210-S													
$\varnothing d_1$	P	l_1	l_2	l_3	d_2	a				ID	ID	ID	ID
M	mm	mm	mm	mm	mm	mm							
3	0.50	40	11.0	18	3.50	2.70	3	2.50		174678	174687	174696	173676
4	0.70	45	13.0	21	4.50	3.40	3	3.30		174679	174688	174697	173644
5	0.80	50	16.0	24	6.00	4.90	3	4.20		174680	174689	174698	173677
6	1.00	56	19.0	27	6.00	4.90	3	5.00		174681	174690	174699	173394
										NP210-1	NP210-2	NP210-3	NP210-S
$\varnothing d_1$	P	l_1	l_2		d_2	a				ID	ID	ID	ID
M	mm	mm	mm		mm	mm							
8	1.25	63	22.0		6.00	4.90	3	6.80		174682	174691	174700	173645
10	1.50	70	24.0		7.00	5.50	3	8.50		174683	174692	174701	173646
12	1.75	75	28.0		9.00	7.00	3	10.20		174684	174693	174702	173647

	N						
特点 Characteristics				 V	 TiN	 R15	 R40
							
洞型 Hole type							
		N320-3	N320-4			N350-3	N360-3
DIN 标准 长型 DIN long	DIN 371	84	84			84	91
ISO 标准 短型 ISO short	ISO 529						
DIN 标准 长型 DIN long	~DIN 2174						
公差 Tolerance	ISO 2 6H		84			84	91
精密公差 Fine tolerance	ISO 1 4H	84					
尺寸偏大 Oversize	ISO 3 6G						91
	N410-3	N420-3	N420-4	N420V-4	N420TN-4	N450-3	N460-3
DIN 标准 长型 DIN long	DIN 374	85/90	88/89	85/90	85/88	85/86	84
ISO 标准 短型 ISO short	ISO 529						
DIN 标准 长型 DIN long	~DIN 2174						
公差 Tolerance	ISO 2 6H	85/90		85/90	85/88	85/86	84
精密公差 Fine tolerance	ISO 1 4H						
尺寸偏大 Oversize	ISO 3 6G						92
公差 Tolerance	7H (EN 60423)		88/89				
LH 左旋螺纹 LH Left hand thread	ISO 2 6H	90		90			

N					Z			
								
								
								
								
N360V-3	N360TN-3	N1110-1	N1110-3	N1110-S	Z320V-3 Z320V-4	Z320VS-4	Z360V-3	Z370VS-3
91	91	106	106	106	94	94	94	94
91	91		106	106	94	94	94	94
					94			
N460V-3	N460TN-3	N1210-1	N1210-3	N1210-S	Z420V-4	Z420VS-4	Z460V-3	Z470VS-3
92/93	92	107/108	107/108	107/108	95	95	95	95
92/93	92		107/108	107/108	95	95	95	95

	H		S		SA		
特点 Characteristics			 VS	 VS			
							
洞型 Hole type							
	H320-4	H350-3	S320VS-4	S360VS-3	SA320-4	SA350-3	SA390-3
DIN 标准 长型 DIN long	DIN 371						
ISO 标准 短型 ISO short	ISO 529						
DIN 标准 长型 DIN long	~DIN 2174						
公差 Tolerance	ISO 2 6H						
精密公差 Fine tolerance	ISO 1 4H						
尺寸偏大 Oversize	ISO 3 6G						
	H420-4	H450-3	S420VS-4	S460VS-3	SA420-4	SA450-3	
DIN 标准 长型 DIN long	DIN 374						
ISO 标准 短型 ISO short	ISO 529						
DIN 标准 长型 DIN long	~DIN 2174						
公差 Tolerance	ISO 2 6H						
精密公差 Fine tolerance	ISO 1 4H						

TL		K	RTS		FPS		FAS	
		 TiCN						
VS	VS		VS	VS	CrN	VS	VS	
		 NEW						
								
TL320VS-4	TL351VS-3	K313TC-3	RTS320VS-4	RTS362VS-3	FPS381CN-3	FPS381VS-3	FAS381VS-3	
100	100	103	102	102				
					104	104	105	
100	100	103	102	102	104	104	105	
100	100							
TL420VS-4	TL451VS-3	K413TC-3	RTS420VS-4	RTS462VS-3	FPS481CN-3	FPS481VS-3	FAS481VS-3	
101	101	103	102	102				
						104	105	
101	101	103	102	102		104	105	
101	101							

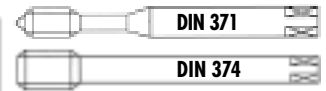

										N320-4		N350-3	N450-3					
N320-4																		
N350-3																		
N450-3																		
Ø d ₁ MF	P mm	l ₁ mm	l ₂ mm	l ₃ mm	d ₂ mm	a mm			ID									
*2	0.25	45	8.0		2.8	2.1	2	1.75	142689									
2.5	0.35	50	10.0		2.8	2.1	3	2.15	142691									
2.6	0.35	50	10.0		2.8	2.1	3	2.25	142692									
3	0.35	56	12.0	18	3.5	2.7	3	2.65	142693									
3.5	0.35	56	13.0	20	4.0	3.0	3	3.15	142694									
Ø d ₁ MF	P mm	l ₁ mm	l ₂ mm	l ₃ mm	d ₂ mm	a mm			ID	ID								
4	0.50	63	14.0	21	4.5	3.4	2	3.50		101586								
5	0.50	70	15.0	25	6.0	4.9	3	4.50		101588								
6	0.75	80	17.0	30	6.0	4.9	3	5.25		101590								
8	1.00	90	20.0		6.0	4.9	3	7.00						102326				
9	0.75	90	20.0		7.0	5.5	3	8.25						102328				
10	1.00	100	22.0		7.0	5.5	3	9.00						102313				
12	1.00	100	24.0		9.0	7.0	3	11.00						* 102315				
12	1.50	100	24.0		9.0	7.0	3	10.50						* 102316				
14	1.50	100	24.0		11.0	9.0	3	12.50						* 102318				
16	1.50	100	26.0		12.0	9.0	3	14.50						* 102320				
18	1.50	110	26.0		14.0	11.0	4	16.50						* 102322				
20	1.50	125	28.0		16.0	12.0	4	18.50						* 102323				
<p>* N320-3 </p>										<p>P 0.25 </p>								

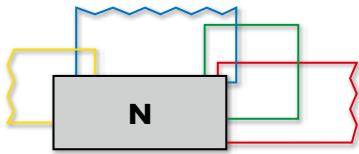

N410-3		
N420-4		
N420V-4	V	
N420TN-4	TiN	



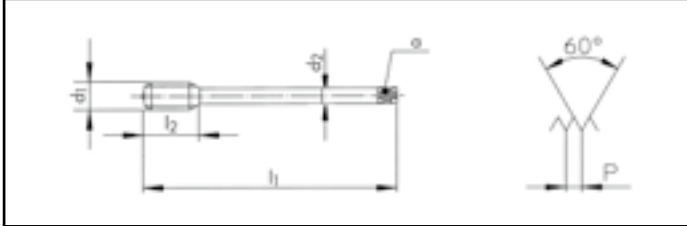
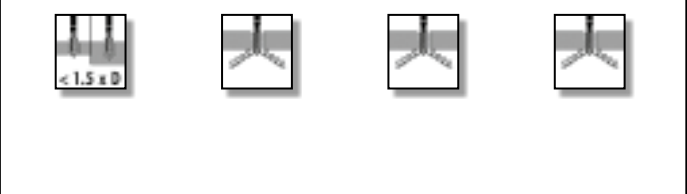



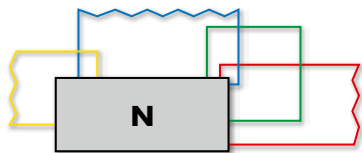

N410-3	N420-4	N420V-4	N420TN-4
--------	--------	---------	----------











ISO 2 6H	ISO 2 6H	ISO 2 6H	ISO 2 6H





MF	∅ d ₁ mm	P mm	l ₁ mm	l ₂ mm	d ₂ mm	a mm			ID	ID	ID	ID
4	0.35	63	14.0	2.8	2.1	3	3.65					
4	0.50	63	14.0	2.8	2.1	3	3.50	101923	102145	142715		
4.5	0.50	70	15.0	3.5	2.7	3	4.00		102150			
5	0.50	70	15.0	3.5	2.7	3	4.50	101941	102167	142716		
5	0.75	70	15.0	3.5	2.7	3	4.25		102168			
5.5	0.50	80	17.0	4.0	3.0	3	5.00		142696			
6	0.50	80	17.0	4.5	3.4	3	5.50	101951	102178	142717		
6	0.75	80	17.0	4.5	3.4	3	5.25	101952	102179	102281	102249	
7	0.50	80	17.0	5.5	4.3	3	6.50		102187			
7	0.75	80	17.0	5.5	4.3	3	6.25	101954	102188			
8	0.50	90	20.0	6.0	4.9	3	7.50	101955	102190	142718		
8	0.75	90	20.0	6.0	4.9	3	7.25	101956	102191	102283		
8	1.00	90	20.0	6.0	4.9	3	7.00	101957	102192	102284	102250	
9	0.50	90	20.0	7.0	5.5	3	8.50		142697			
9	0.75	90	20.0	7.0	5.5	3	8.25		102200			
9	1.00	90	20.0	7.0	5.5	3	8.00		102201	143935		
10	0.50	100	22.0	7.0	5.5	3	9.50		142698			
10	0.75	100	22.0	7.0	5.5	3	9.25	101863	102056			
10	1.00	100	22.0	7.0	5.5	3	9.00	101864	102057	102262	102239	
10	1.25	100	22.0	7.0	5.5	3	8.80	101865	102058	142719		



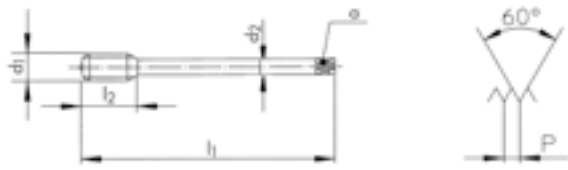

N410-3		
N420-4		
N420V-4	 V	
N420TN-4	 TiN	

N410-3	N420-4	N420V-4	N420TN-4
			
			







			
ISO 2 6H	ISO 2 6H	ISO 2 6H	ISO 2 6H

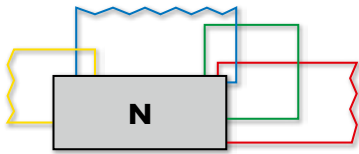

∅ d ₁ MF	P mm	l ₁ mm	l ₂ mm	d ₂ mm	a mm			ID	ID	ID	ID
11	0.50	100	19.0	8.0	6.2	3	10.50		142699		
11	0.75	100	19.0	8.0	6.2	3	10.25		142700		
11	1.00	100	19.0	8.0	6.2	3	10.00		142701		
11	1.25	100	19.0	8.0	6.2	3	9.80		142702		
12	0.50	100	14.0	9.0	7.0	3	11.50		102066		
12	0.75	100	24.0	9.0	7.0	3	11.25		142703		
12	1.00	100	24.0	9.0	7.0	3	11.00	101867	102067	142345	102241
12	1.25	100	24.0	9.0	7.0	3	10.80	101868	102068	142721	
12	1.50	100	24.0	9.0	7.0	3	10.50	101869	102069	102264	102242
13	1.00	100	21.0	11.0	9.0	3	12.00	158401	142704		
14	0.50	100	14.0	11.0	9.0	3	13.50		142705		
14	0.75	100	24.0	11.0	9.0	3	13.25		142706		
14	1.00	100	24.0	11.0	9.0	3	13.00	101871	102077		
14	1.25	100	24.0	11.0	9.0	3	12.80	101872	102078		
14	1.50	100	24.0	11.0	9.0	3	12.50	101873	102079	102266	102244
15	1.00	100	26.0	12.0	9.0	3	14.00	101875	102085		
15	1.50	100	26.0	12.0	9.0	3	13.50	101876	102086		
16	0.75	100	26.0	12.0	9.0	3	15.25		142708		
16	1.00	100	26.0	12.0	9.0	*3	15.00	101877	102087		
16	1.25	100	26.0	12.0	9.0	*3	14.80	101878	102088		
16	1.50	100	26.0	12.0	9.0	*3	14.50	101879	102089	102268	102246
17	1.00	100	26.0	12.0	9.0	3	16.00		142709		
17	1.50	100	26.0	12.0	9.0	3	15.50		142710		
18	0.75	110	26.0	14.0	11.0	4	17.25		142711		
18	1.00	110	26.0	14.0	11.0	4	17.00	101881	102095		
18	1.50	110	26.0	14.0	11.0	4	16.50	101882	102096	102270	
18	2.00	125	33.0	14.0	11.0	3	16.00		142712		
19	1.00	110	26.0	14.0	11.0	4	18.00		* 142713		

* N410-3 =  4









N410-3  

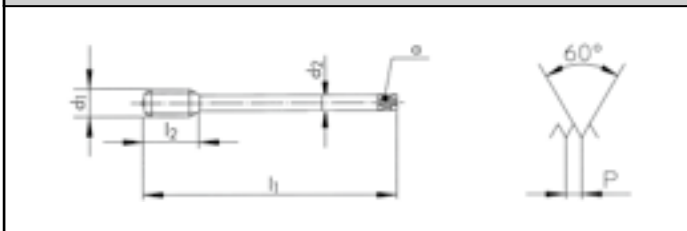
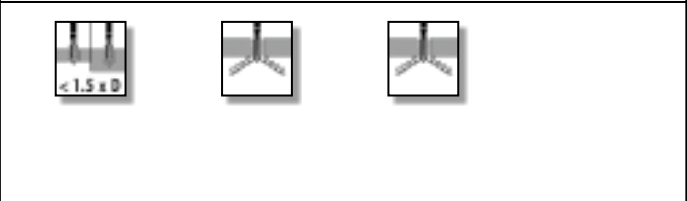

N420-4  

N420V-4   

N410-3	N420-4	N420V-4	
--------	--------	---------	--



$\varnothing d_1$ MF	P mm	l_1 mm	l_2 mm	d_2 mm	α mm			ID	ID	ID
20	1.00	125	28.0	16.0	12.0	4	19.00		102098	
20	1.50	125	28.0	16.0	12.0	4	18.50	101884	102099	102272
20	2.00	140	36.0	16.0	12.0	3	18.00	105130	102100	
22	1.00	125	28.0	18.0	14.5	4	21.00		102104	
22	1.50	125	28.0	18.0	14.5	4	20.50	101886	102105	102274
22	2.00	140	36.0	18.0	14.5	3	20.00	101887	142714	
24	1.00	140	30.0	18.0	14.5	4	23.00		102107	
24	1.50	140	30.0	18.0	14.5	4	22.50	101889	102108	102276
24	2.00	140	34.0	18.0	14.5	4	22.00	101890	102109	102277
25	1.00	140	30.0	18.0	14.5	4	24.00		142722	
25	1.50	140	30.0	18.0	14.5	4	23.50	101892	102112	
25	2.00	140	34.0	18.0	14.5	4	23.00		142723	
26	1.00	140	30.0	18.0	14.5	4	25.00		102113	
26	1.50	140	30.0	18.0	14.5	4	24.50	101893	102114	145896
27	1.50	140	34.0	20.0	16.0	4	25.50		102115	
27	2.00	140	34.0	20.0	16.0	4	25.00	101894	102116	
28	1.00	140	30.0	20.0	16.0	4	27.00		142725	
28	1.50	140	30.0	20.0	16.0	4	26.50	101896	102118	
28	2.00	140	30.0	20.0	16.0	4	26.00	122023		

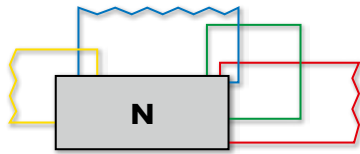

N410-3		
N420-4		
N420V-4	V	
N420-3		

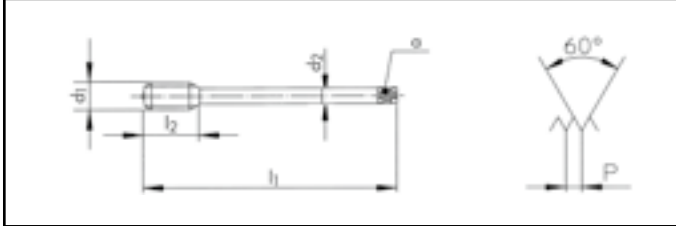
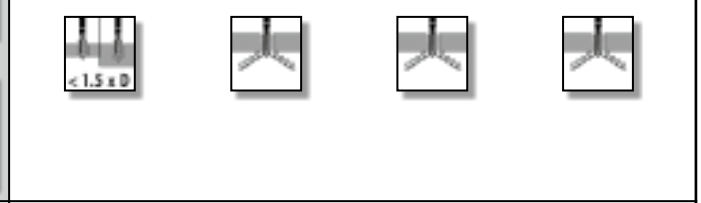

ISO 2 6H	ISO 2 6H	ISO 2 6H	ISO 3 7H

$\varnothing d_1$ MF	P mm	l_1 mm	l_2 mm	d_2 mm	a mm		$6H$ 	ID	ID	ID	ID
30	1.00	150	32.0	22.0	18.0	4	29.00	101898	102121		
30	1.50	150	32.0	22.0	18.0	4	28.50	101899	102122	143978	
30	2.00	150	32.0	22.0	18.0	4	28.00	101900	102123	143766	
32	1.00	150	32.0	22.0	18.0	4	31.00	101902			
32	1.50	150	32.0	22.0	18.0	4	30.50	101903	102126		143812
32	2.00	150	32.0	22.0	18.0	4	30.00	101904	102127		
33	1.50	160	32.0	25.0	20.0	4	31.50	101905	102128		
33	2.00	160	32.0	25.0	20.0	4	31.00	101906	102129		
34	1.00	170	32.0	28.0	22.0	4	33.00	* 101908			
34	1.50	170	32.0	28.0	22.0	4	32.50	101909	* 102131		
35	1.50	170	32.0	28.0	22.0	4	33.50	101910	102132		
35	2.00	170	32.0	28.0	22.0	4	33.00	101911			
36	1.00	170	34.0	28.0	22.0	4	35.00		* 102133		
36	1.50	170	34.0	28.0	22.0	4	34.50	101912	102134		
36	2.00	170	34.0	28.0	22.0	4	34.00	101913	102135		
36	3.00	200	45.0	28.0	22.0	4	33.00	101914	102136		
38	1.00	170	34.0	28.0	22.0	4	37.00	* 101916	* 102138		
38	1.50	170	34.0	28.0	22.0	4	36.50	101917	102139		
38	2.00	170	34.0	28.0	22.0	4	36.00	101918			
39	2.00	170	34.0	32.0	24.0	4	37.00	101920			
39	3.00	200	45.0	32.0	24.0	4	36.00	101921			

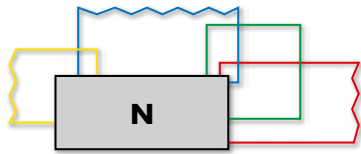

N410-3

N420-4

N420-3

N410-3





N420-4

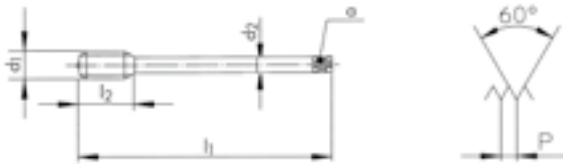

N420-3



MF	∅ d ₁ mm	P mm	l ₁ mm	l ₂ mm	d ₂ mm	α mm		 6H
40	1.00	170	34.0	32.0	24.0	5	39.00	
40	1.50	170	34.0	32.0	24.0	5	38.50	
40	2.00	170	34.0	32.0	24.0	5	38.00	
40	3.00	200	45.0	32.0	24.0	4	37.00	
42	1.50	170	34.0	32.0	24.0	5	40.50	
42	2.00	170	34.0	32.0	24.0	5	40.00	
42	3.00	200	45.0	32.0	24.0	4	39.00	
45	1.50	180	34.0	36.0	29.0	5	43.50	
45	2.00	180	34.0	36.0	29.0	5	43.00	
45	3.00	200	45.0	36.0	29.0	4	42.00	
48	1.50	190	36.0	36.0	29.0	5	46.50	
48	2.00	190	36.0	36.0	29.0	5	46.00	
48	3.00	220	48.0	36.0	29.0	5	45.00	
50	1.50	190	36.0	36.0	29.0	5	48.50	
50	2.00	190	36.0	36.0	29.0	5	48.00	
52	1.50	190	36.0	40.0	32.0	5	50.50	
52	2.00	190	36.0	40.0	32.0	5	50.00	
52	3.00	220	48.0	40.0	32.0	5	49.00	
55	2.00	190	40.0	40.0	32.0	5	53.00	
60	2.00	220	42.0	45.0	35.0	5	58.00	
63	1.50	220	38.0	45.0	35.0	5	61.50	

ID

ID

ID

101925

101926

102152

143813

101927

102153

* 101928

* 102154

101929

102155

101930

102156

101931

102157

101933

102159

101934

101935

* 102161

101937

102163

101938

102164

101939

102165

101943

102176

143814

* 101944

* 102177

* 101946

101947

* 101948

* 105131

105132

143815

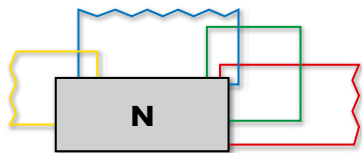

N410-3 LH





N420-4 LH

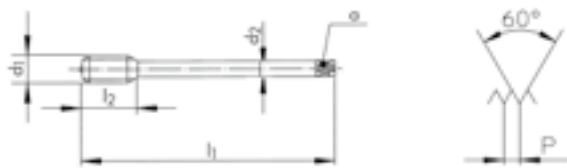

N410-3 LH

N420-4 LH



$\varnothing d_1$ MF	P mm	l_1 mm	l_2 mm	d_2 mm	a mm			ID	ID
4	0.50	63	14.0	2.8	2.1	3	3.50	104844	
5	0.50	70	15.0	3.5	2.7	3	4.50	104845	
6	0.50	80	17.0	4.5	3.4	3	5.50	104846	104870
6	0.75	80	17.0	4.5	3.4	3	5.25	104847	105133
7	0.75	80	17.0	5.5	4.3	3	6.25	104848	
8	0.50	90	20.0	6.0	4.9	3	7.50	104849	
8	0.75	90	20.0	6.0	4.9	3	7.25	104850	104871
8	1.00	90	20.0	6.0	4.9	3	7.00	104851	104872
10	0.75	100	22.0	7.0	5.5	3	9.25	104852	
10	1.00	100	22.0	7.0	5.5	3	9.00	104853	104873
10	1.25	100	22.0	7.0	5.5	3	8.80		104874
12	1.00	100	24.0	9.0	7.0	3	11.00	104854	104875
12	1.25	100	24.0	9.0	7.0	3	10.80	104855	104876
12	1.50	100	24.0	9.0	7.0	3	10.50	104856	104877
14	1.00	100	24.0	11.0	9.0	3	13.00	104857	104878
14	1.25	100	24.0	11.0	9.0	3	12.80	104858	
14	1.50	100	24.0	11.0	9.0	3	12.50	104859	104879
16	1.00	100	26.0	12.0	9.0	*3	15.00	104860	104880
16	1.50	100	26.0	12.0	9.0	*3	14.50	104861	104881
18	1.00	110	26.0	14.0	11.0	4	17.00	104862	
18	1.50	110	26.0	14.0	11.0	4	16.50	104863	104882
20	1.00	125	28.0	16.0	12.0	4	19.00	104864	
20	1.50	125	28.0	16.0	12.0	4	18.50	104865	104883
22	1.50	125	28.0	18.0	14.5	4	20.50	104866	104884
24	1.50	140	30.0	18.0	14.5	4	22.50	104867	104885
24	2.00	140	34.0	18.0	14.5	4	22.00	104868	104886
28	1.50	140	30.0	20.0	16.0	4	26.50	105166	
30	1.50	150	32.0	22.0	18.0	4	28.50	105167	105165
30	2.00	150	32.0	22.0	18.0	4	28.00	105168	

* N410-3 LH =  4

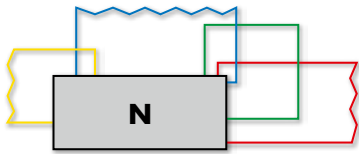

N360-3 N360V-3 N360TN-3 N360-3

N360-3



N360V-3



N360TN-3

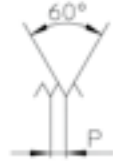
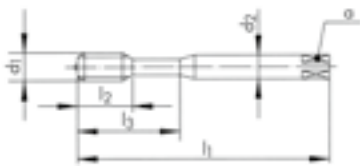

∅ d ₁ MF	P mm	l ₁ mm	l ₂ mm	l ₃ mm	d ₂ mm	a mm		
4	0.50	63	7.5	21	4.5	3.4	3	3.50
5	0.50	70	9.0	25	6.0	4.9	3	4.50
6	0.50	80	11.0	30	6.0	4.9	3	5.50
6	0.75	80	11.0	30	6.0	4.9	3	5.25
8	0.75	90	12.5	35	8.0	6.2	3	7.25
8	1.00	90	12.5	35	8.0	6.2	3	7.00
10	0.75	100	14.0	39	10.0	8.0	3	9.25
10	1.00	100	14.0	39	10.0	8.0	3	9.00
10	1.25	100	14.0	39	10.0	8.0	3	8.80

ID	ID	ID	ID	6H + mm
101632	101712	111618	101631	0.020
101641	101714	111617	101640	0.020
101648	143990			
101650	101716	101702	101649	0.022
101658	101719		101657	0.022
101660	101720	101704	101659	0.026
101606	144401			
101608	101706	101695	101607	0.026
101609	105134	110965		

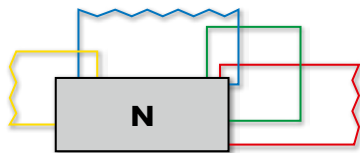

N460-3



N460V-3



N460TN-3



N460-3

N460V-3

N460TN-3

N460-3

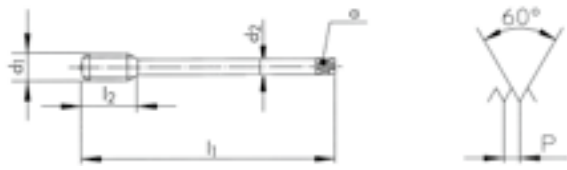



ISO 2
6H

ISO 2
6H

ISO 2
6H

ISO 3
6G

MF	∅ d ₁ mm	P mm	l ₁ mm	l ₂ mm	d ₂ mm	a mm		6H 	ID	ID	ID	ID ^{6H} + mm
12	1.00	100	14.0	9.0	7.0	3	11.00	102353	102462	102447	102352	0.026
12	1.25	100	14.0	9.0	7.0	3	10.80	102354	102463	144202		
12	1.50	100	14.0	9.0	7.0	3	10.50	102356	102464	102448	102355	0.032
13	1.00	100	14.0	11.0	9.0	3	12.00	102364				
14	1.00	100	14.0	11.0	9.0	3	13.00	102365	102466			
14	1.50	100	14.0	11.0	9.0	3	12.50	102367	102467	102450	102366	0.032
15	1.00	100	14.0	12.0	9.0	3	14.00	102370				
15	1.50	100	18.0	12.0	9.0	3	13.50	102371				
16	1.00	100	14.0	12.0	9.0	4	15.00	102372	102469			
16	1.50	100	14.0	12.0	9.0	4	14.50	102374	102470	102452	102373	0.032
18	1.00	110	18.0	14.0	11.0	4	17.00	102380	143926			
18	1.50	110	18.0	14.0	11.0	4	16.50	102382	102472		102381	0.032
20	1.00	125	20.0	16.0	12.0	4	19.00	102384	146377			
20	1.50	125	20.0	16.0	12.0	4	18.50	102386	102474			
20	2.00	140	24.0	16.0	12.0	4	18.00	102387	143566			
22	1.00	125	20.0	18.0	14.5	4	21.00	102392	147702			
22	1.50	125	20.0	18.0	14.5	4	20.50	102393	102476			
24	1.50	140	22.0	18.0	14.5	4	22.50	102396	102478			
24	2.00	140	22.0	18.0	14.5	4	22.00	102397	102479			
25	1.50	140	22.0	18.0	14.5	4	23.50	102399	143810			
26	1.50	140	22.0	18.0	14.5	4	24.50	102400	143952			
27	1.50	140	22.0	20.0	16.0	4	25.50	102401	143965			
27	2.00	140	22.0	20.0	16.0	4	25.00	102402	144201			
28	1.50	140	22.0	20.0	16.0	4	26.50	102403	144997			

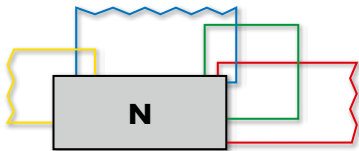

N460-3

N460V-3

N460-3



N460V-3

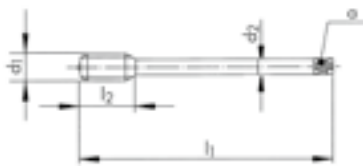

ISO 2
6H

ISO 2
6H

MF	$\varnothing d_1$ mm	P mm	l_1 mm	l_2 mm	d_2 mm	α mm		$\pm 6H$ mm
30	1.50	150	24.0	22.0	18.0	4	28.50	
30	2.00	150	24.0	22.0	18.0	4	28.00	
32	1.50	150	24.0	22.0	18.0	4	30.50	
33	2.00	160	26.0	25.0	20.0	4	31.00	
33	3.00	180	33.0	25.0	20.0	4	30.00	
35	1.50	170	24.0	28.0	22.0	5	33.50	
36	1.50	170	24.0	28.0	22.0	5	34.50	
36	2.00	170	28.0	28.0	22.0	5	34.00	
36	3.00	200	36.0	28.0	22.0	4	33.00	
39	3.00	200	40.0	32.0	24.0	5	36.00	
42	3.00	200	40.0	32.0	24.0	5	39.00	

ID

ID

102404

142524

102405

142581

102406

143605

102407

147604

175437

150448

102408

146846

102409

143824

175436

164870

115072

150453

174995

122669

174996

150436

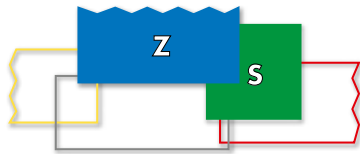

Z320V-4		V	
Z320VS-4		VS	
Z360V-3		V	
Z370VS-3		VS	

Z320V-4	Z320VS-4	Z360V-3	Z370VS-3
	NEW		
			PM

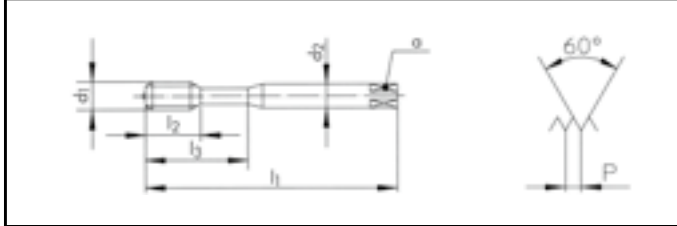

ISO 2 6H	ISO 2 6H	ISO 2 6H	6HX

∅ d ₁ MF	P mm	l ₁ mm	l ₂ mm	l ₃ mm	d ₂ mm	a mm		
*2	0.20	45	8.0		2.8	2.1	2	1.80
*2	0.25	45	8.0		2.8	2.1	2	1.75
*2.2	0.25	45	9.0		2.8	2.1	2	1.95
2.5	0.20	50	10.0		2.8	2.1	3	2.30
2.5	0.25	50	10.0		2.8	2.1	3	2.25
3	0.35	56	12.0	18	3.5	2.7	3	2.65
6	0.75	80	17.0	30	6.0	4.9	3	5.25
8	1.00	90	20.0	35	8.0	6.2	3	7.00
10	1.00	100	22.0	39	10.0	8.0	3	9.00

ID	ID
146487	
114715	
115462	
115578	
115887	
115468	
142726	
142727	124289
142728	120060

∅ d ₁ MF	P mm	l ₁ mm	l ₂ mm	l ₃ mm	d ₂ mm	a mm		
4	0.50	63	7.5	21	4.5	3.4	3	3.50
5	0.50	70	9.0	25	6.0	4.9	3	4.50
6	0.75	80	11.0	30	6.0	4.9	3	5.25
8	1.00	90	12.5	35	8.0	6.2	3	7.00
10	1.00	100	14.0	39	10.0	8.0	3	9.00

ID
104675
104676
104677
104678
104674

∅ d ₁ MF	P mm	l ₁ mm	l ₂ mm	l ₃ mm	d ₂ h ₆ mm	a mm		
6	0.75	80	11.0	30	6.0	4.9	3	5.25
8	1.00	90	12.5	35	8.0	6.2	3	7.00
10	1.00	100	14.0	39	10.0	8.0	3	9.00

ID
166117
166118
166119

* Z320V-3

P ≤ 0.25 **ISO 1 4H**

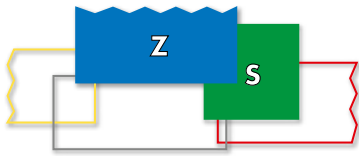

Z420V-4 Z420VS-4 Z460V-3 Z470VS-3



Z420V-4



Z420VS-4



Z460V-3



Z470VS-3



PM



ISO 2 6H ISO 2 6H ISO 2 6H 6HX

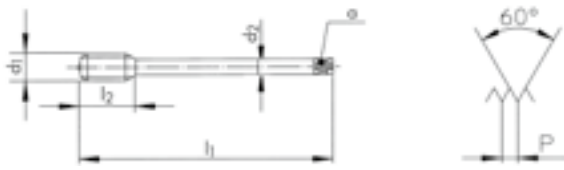

∅ d ₁ MF	P mm	l ₁ mm	l ₂ mm	d ₂ mm	a mm		
12	1.00	100	24.0	9.0	7.0	3	11.00
12	1.50	100	24.0	9.0	7.0	3	10.50
14	1.50	100	24.0	11.0	9.0	3	12.50
16	1.50	100	26.0	12.0	9.0	3	14.50

ID	ID
142729	
142730	120421
142731	120688
142732	120878

∅ d ₁ MF	P mm	l ₁ mm	l ₂ mm	d ₂ mm	a mm		
12	1.00	100	14.0	9.0	7.0	3	11.00
12	1.50	100	14.0	9.0	7.0	3	10.50
14	1.50	100	14.0	11.0	9.0	3	12.50
16	1.50	100	14.0	12.0	9.0	4	14.50
18	1.50	110	18.0	14.0	11.0	4	16.50
20	1.50	125	20.0	16.0	12.0	4	18.50
22	1.50	125	20.0	18.0	14.5	4	20.50
24	1.50	140	22.0	18.0	14.5	4	22.50
24	2.00	140	22.0	18.0	14.5	4	22.00

ID
104729
104730
104731
104732
104733
104734
104735
104736
104737

∅ d ₁ MF	P mm	l ₁ mm	l ₂ mm	d ₂ h ₆ mm	a mm		
12	1.50	110	14.0	*10.0	*8.0	4	10.50
14	1.50	110	14.0	*12.0	*9.0	4	12.50
16	1.50	110	18.0	12.0	9.0	4	14.50

ID
166120
166121
166122

* DC 标准 / * DC Norm

										H320-4	H420-4		
H320-4													
H420-4													
$\varnothing d_1$	P	l_1	l_2	l_3	d_2	α			ID	ID			
MF	mm	mm	mm	mm	mm	mm							
6	0.75	80	17.0	30	6.0	4.9	3	5.25	101214				
8	0.75	90	20.0	35	8.0	6.2	3	7.25	101216				
8	1.00	90	20.0	35	8.0	6.2	3	7.00	101217				
10	1.00	100	22.0	39	10.0	8.0	3	9.00	101204				
12	1.25	100	24.0		9.0	7.0	4	10.80		101273			
12	1.50	100	24.0		9.0	7.0	4	10.50		101274			
14	1.50	100	24.0		11.0	9.0	4	12.50		101276			
16	1.50	100	26.0		12.0	9.0	4	14.50		101278			
20	1.50	125	28.0		16.0	12.0	4	18.50		101282			
24	2.00	140	34.0		18.0	14.5	4	22.00		101285			

MF ISO DIN 13

≤ Ø 25.4 > Ø 25.4

PM **HSSE**

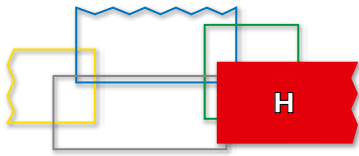
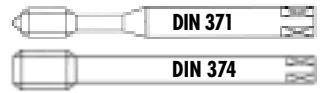

H350-3

H450-3

H350-3



H450-3

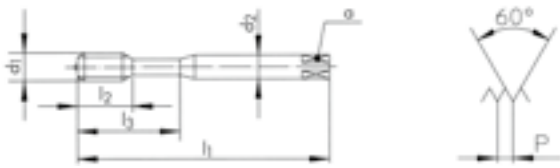

Ø d ₁ MF	P mm	l ₁ mm	l ₂ mm	l ₃ mm	d ₂ mm	a mm		
6	0.75	80	11.0	30	6.0	4.9	3	5.25
8	0.75	90	12.5	35	8.0	6.2	3	7.25
8	1.00	90	12.5	35	8.0	6.2	3	7.00
10	1.00	100	14.0	39	10.0	8.0	3	9.00
12	1.00	100	14.0		9.0	7.0	4	11.00
12	1.50	100	14.0		9.0	7.0	4	10.50
14	1.50	100	14.0		11.0	9.0	4	12.50
16	1.50	100	14.0		12.0	9.0	4	14.50
18	1.50	110	18.0		14.0	11.0	4	16.50
20	1.50	125	20.0		16.0	12.0	4	18.50
22	1.50	125	20.0		18.0	14.5	4	20.50
24	1.50	140	22.0		18.0	14.5	4	22.50
24	2.00	140	22.0		18.0	14.5	4	22.00
27	2.00	140	22.0		20.0	16.0	4	25.00
30	1.50	150	24.0		22.0	18.0	4	28.50
30	2.00	150	24.0		22.0	18.0	4	28.00

ID

ID

101249

101252

101253

101235

101302

101303

101306

101308

101310

101312

101314

101316

101317

101319

101321

101322

										S320VS-4	S420VS-4	S360VS-3	S460VS-3
S320VS-4		VS											
S420VS-4		VS											
S360VS-3		VS											
S460VS-3		VS											
$\varnothing d_1$ MF	P mm	l_1 mm	l_2 mm	l_3 mm	d_2 mm	a mm			ID	ID			
6	0.75	80	17.0	30	6.0	4.9	3	5.25	* 123690				
8	1.00	90	20.0	35	8.0	6.2	3	7.00	124288				
10	1.00	100	22.0	39	10.0	8.0	3	9.00	120059				
12	1.50	100	24.0		9.0	7.0	4	10.50		120420			
14	1.50	100	24.0		11.0	9.0	4	12.50		120687			
16	1.50	100	26.0		12.0	9.0	4	14.50		120877			
$\varnothing d_1$ MF	P mm	l_1 mm	l_2 mm	l_3 mm	d_2 mm	a mm				ID	ID		
8	1.00	90	12.5	35	8.0	6.2	3	7.00		111528			
10	1.00	100	14.0	39	10.0	8.0	3	9.00		111529			
12	1.50	100	14.0		9.0	7.0	4	10.50			111540		
14	1.50	100	14.0		11.0	9.0	4	12.50			111541		
16	1.50	100	14.0		12.0	9.0	4	14.50			111542		

aero

SA390-3

SA390-3

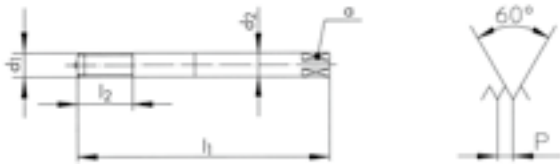

$\varnothing d_1$ MF	P mm	l_1 mm	l_2 mm	d_2 mm	α mm		
8	1.00	90	25.0	8.0	6.2	3	7.00
10	1.00	100	30.0	10.0	8.0	3	9.00
10	1.25	100	30.0	10.0	8.0	3	8.80
12	1.00	110	35.0	12.0	9.0	4	11.00
12	1.50	110	35.0	12.0	9.0	4	10.50
14	1.50	110	40.0	16.0	12.0	4	12.50

ID

* 149735

* 149751

* 149753

* 149769

* 149773

* 149790

MF

aero

										SA320-4	SA350-3	TL320VS-4	TL351VS-3																																																																																																	
<div style="display: flex; justify-content: space-between;"> <div style="width: 45%;"> <p>SA320-4 52 53</p> <p>SA350-3 52 53</p> <p>TL320VS-4 VS 41 42</p> <p>TL351VS-3 VS 41 42</p> </div> <div style="width: 50%; text-align: center;"> </div> </div>																																																																																																														
										<div style="display: flex; justify-content: space-around;"> <div style="border: 1px solid black; padding: 5px;">4HX</div> <div style="border: 1px solid black; padding: 5px;">4HX</div> <div style="border: 1px solid black; padding: 5px;">4HX</div> <div style="border: 1px solid black; padding: 5px;">4HX</div> </div>																																																																																																				
<table border="1" style="width: 100%; border-collapse: collapse;"> <thead> <tr> <th>$\varnothing d_1$</th> <th>P</th> <th>l_1</th> <th>l_2</th> <th>l_3</th> <th>d_2</th> <th>a</th> <th></th> <th></th> <th>ID</th> <th>ID</th> <th>ID</th> <th>ID</th> </tr> <tr> <th>MF</th> <th>mm</th> <th>mm</th> <th>mm</th> <th>mm</th> <th>mm</th> <th>mm</th> <th></th> <th>$\rightarrow \leftarrow$</th> <th></th> <th></th> <th></th> <th></th> </tr> </thead> <tbody> <tr> <td>4</td> <td>0.50</td> <td>63</td> <td>14.0</td> <td></td> <td>4.5</td> <td>3.4</td> <td>3</td> <td>3.50</td> <td></td> <td>* 149079</td> <td>* 152032</td> <td>152033</td> </tr> <tr> <td>5</td> <td>0.50</td> <td>70</td> <td>15.0</td> <td></td> <td>6.0</td> <td>4.9</td> <td>3</td> <td>4.50</td> <td>* 149142</td> <td>149144</td> <td>* 152048</td> <td>152049</td> </tr> <tr> <td>6</td> <td>0.50</td> <td>80</td> <td>15.0</td> <td>23</td> <td>6.0</td> <td>4.9</td> <td>3</td> <td>5.50</td> <td>* 149193</td> <td></td> <td>* 152058</td> <td>152059</td> </tr> <tr> <td>8</td> <td>1.00</td> <td>90</td> <td>18.0</td> <td>29</td> <td>8.0</td> <td>6.2</td> <td>3</td> <td>7.00</td> <td>149304</td> <td>149306</td> <td>* 152079</td> <td>152080</td> </tr> <tr> <td>10</td> <td>1.00</td> <td>100</td> <td>20.0</td> <td>33</td> <td>10.0</td> <td>8.0</td> <td>3</td> <td>9.00</td> <td>149362</td> <td>149364</td> <td>* 152092</td> <td>152093</td> </tr> </tbody> </table>										$\varnothing d_1$	P	l_1	l_2	l_3	d_2	a			ID	ID	ID	ID	MF	mm	mm	mm	mm	mm	mm		$\rightarrow \leftarrow$					4	0.50	63	14.0		4.5	3.4	3	3.50		* 149079	* 152032	152033	5	0.50	70	15.0		6.0	4.9	3	4.50	* 149142	149144	* 152048	152049	6	0.50	80	15.0	23	6.0	4.9	3	5.50	* 149193		* 152058	152059	8	1.00	90	18.0	29	8.0	6.2	3	7.00	149304	149306	* 152079	152080	10	1.00	100	20.0	33	10.0	8.0	3	9.00	149362	149364	* 152092	152093										
$\varnothing d_1$	P	l_1	l_2	l_3	d_2	a			ID	ID	ID	ID																																																																																																		
MF	mm	mm	mm	mm	mm	mm		$\rightarrow \leftarrow$																																																																																																						
4	0.50	63	14.0		4.5	3.4	3	3.50		* 149079	* 152032	152033																																																																																																		
5	0.50	70	15.0		6.0	4.9	3	4.50	* 149142	149144	* 152048	152049																																																																																																		
6	0.50	80	15.0	23	6.0	4.9	3	5.50	* 149193		* 152058	152059																																																																																																		
8	1.00	90	18.0	29	8.0	6.2	3	7.00	149304	149306	* 152079	152080																																																																																																		
10	1.00	100	20.0	33	10.0	8.0	3	9.00	149362	149364	* 152092	152093																																																																																																		
										<div style="display: flex; justify-content: space-around;"> <div style="border: 1px solid black; padding: 5px;">6HX</div> <div style="border: 1px solid black; padding: 5px;">6HX</div> <div style="border: 1px solid black; padding: 5px;">6HX</div> <div style="border: 1px solid black; padding: 5px;">6HX</div> </div>																																																																																																				
<table border="1" style="width: 100%; border-collapse: collapse;"> <thead> <tr> <th>$\varnothing d_1$</th> <th>P</th> <th>l_1</th> <th>l_2</th> <th>l_3</th> <th>d_2</th> <th>a</th> <th></th> <th></th> <th>ID</th> <th>ID</th> <th>ID</th> <th>ID</th> </tr> <tr> <th>MF</th> <th>mm</th> <th>mm</th> <th>mm</th> <th>mm</th> <th>mm</th> <th>mm</th> <th></th> <th>$\rightarrow \leftarrow$</th> <th></th> <th></th> <th></th> <th></th> </tr> </thead> <tbody> <tr> <td>4</td> <td>0.50</td> <td>63</td> <td>14.0</td> <td></td> <td>4.5</td> <td>3.4</td> <td>3</td> <td>3.50</td> <td>149081</td> <td>149083</td> <td>* 152034</td> <td>152035</td> </tr> <tr> <td>5</td> <td>0.50</td> <td>70</td> <td>15.0</td> <td></td> <td>6.0</td> <td>4.9</td> <td>3</td> <td>4.50</td> <td>149146</td> <td>149148</td> <td>* 152050</td> <td>152051</td> </tr> <tr> <td>6</td> <td>0.50</td> <td>80</td> <td>15.0</td> <td>23</td> <td>6.0</td> <td>4.9</td> <td>3</td> <td>5.50</td> <td></td> <td>* 149199</td> <td>* 152060</td> <td>152061</td> </tr> <tr> <td>8</td> <td>1.00</td> <td>90</td> <td>18.0</td> <td>29</td> <td>8.0</td> <td>6.2</td> <td>3</td> <td>7.00</td> <td>149308</td> <td>149310</td> <td></td> <td>148019</td> </tr> <tr> <td>10</td> <td>1.00</td> <td>100</td> <td>20.0</td> <td>33</td> <td>10.0</td> <td>8.0</td> <td>3</td> <td>9.00</td> <td>149366</td> <td>149368</td> <td>* 152094</td> <td>148026</td> </tr> </tbody> </table>										$\varnothing d_1$	P	l_1	l_2	l_3	d_2	a			ID	ID	ID	ID	MF	mm	mm	mm	mm	mm	mm		$\rightarrow \leftarrow$					4	0.50	63	14.0		4.5	3.4	3	3.50	149081	149083	* 152034	152035	5	0.50	70	15.0		6.0	4.9	3	4.50	149146	149148	* 152050	152051	6	0.50	80	15.0	23	6.0	4.9	3	5.50		* 149199	* 152060	152061	8	1.00	90	18.0	29	8.0	6.2	3	7.00	149308	149310		148019	10	1.00	100	20.0	33	10.0	8.0	3	9.00	149366	149368	* 152094	148026										
$\varnothing d_1$	P	l_1	l_2	l_3	d_2	a			ID	ID	ID	ID																																																																																																		
MF	mm	mm	mm	mm	mm	mm		$\rightarrow \leftarrow$																																																																																																						
4	0.50	63	14.0		4.5	3.4	3	3.50	149081	149083	* 152034	152035																																																																																																		
5	0.50	70	15.0		6.0	4.9	3	4.50	149146	149148	* 152050	152051																																																																																																		
6	0.50	80	15.0	23	6.0	4.9	3	5.50		* 149199	* 152060	152061																																																																																																		
8	1.00	90	18.0	29	8.0	6.2	3	7.00	149308	149310		148019																																																																																																		
10	1.00	100	20.0	33	10.0	8.0	3	9.00	149366	149368	* 152094	148026																																																																																																		

aero

SA420-4

SA450-3

TL420VS-4

TL451VS-3

SA420-4



SA450-3



TL420VS-4



VS

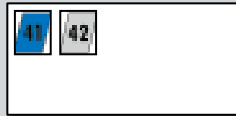

TL451VS-3



VS



4HX

4HX

4HX

4HX

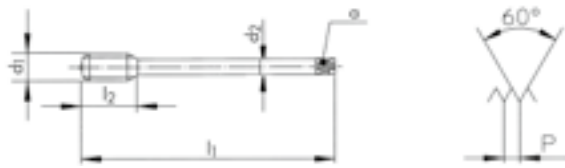

∅ d ₁ MF	P mm	l ₁ mm	l ₂ mm	d ₂ mm	a mm		
12	1.00	100	19.0	9.0	7.0	4	11.00
12	1.50	100	24.0	9.0	7.0	4	10.50
14	1.50	100	24.0	11.0	9.0	4	12.50
16	1.50	100	26.0	12.0	9.0	4	14.50

ID

ID

ID

ID

* 152209		* 152218	
* 152208	* 152213		
* 152210	* 152214		* 152224
* 152212	* 152216		* 152226

6HX

6HX

6HX

6HX

∅ d ₁ MF	P mm	l ₁ mm	l ₂ mm	d ₂ mm	a mm		
12	1.00	100	19.0	9.0	7.0	4	11.00
12	1.50	100	24.0	9.0	7.0	4	10.50
14	1.50	100	24.0	11.0	9.0	4	12.50
16	1.00	100	23.0	12.0	9.0	4	15.00
16	1.50	100	26.0	12.0	9.0	4	14.50

ID

ID

ID

ID

* 152228	* 148967	* 152237	* 152242
* 152227	* 152232		* 152241
* 152229	* 152233	* 152238	* 152243
		* 152239	* 152244
	* 152235	* 152240	* 152245



只适用于刚性攻丝
Only for rigid tapping

PM

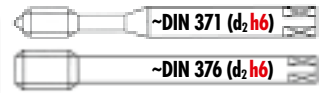

RTS Rigid Tapping Synchro

RTS320VS-4



VS

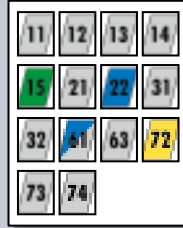

RTS420VS-4



VS

RTS362VS-3



VS

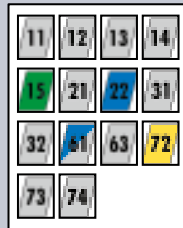

RTS462VS-3



VS

RTS320VS-4

RTS420VS-4

RTS362VS-3

RTS462VS-3

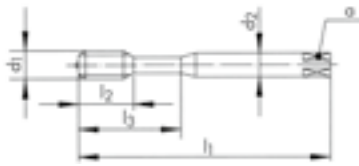

∅ d ₁ MF	P mm	l ₁ mm	l ₂ mm	l ₃ mm	d ₂ h6 mm	a mm		
8	1.00	90	12.5	35	8.0	6.2	3	7.00
10	1.00	100	14.0	39	10.0	8.0	3	9.00
12	1.50	110	14.0		*10.0	*8.0	3	10.50
14	1.50	110	14.0		*12.0	*9.0	3	12.50
16	1.50	110	18.0		12.0	9.0	3	14.50

* DC 标准 / * DC Norm

ID

ID

150615

150630

150640

150655

150665

∅ d ₁ MF	P mm	l ₁ mm	l ₂ mm	l ₃ mm	d ₂ h6 mm	a mm		
8	1.00	90	12.5	35	8.0	6.2	3	7.00
10	1.00	100	14.0	39	10.0	8.0	3	9.00
12	1.50	110	14.0		*10.0	*8.0	3	10.50
14	1.50	110	14.0		*12.0	*9.0	3	12.50
16	1.50	110	18.0		12.0	9.0	3	14.50

* DC 标准 / * DC Norm

ID

ID

150617

150632

151862

151869

151871



应要求
on request

≥ ∅ 6 mm

K

K313TC-3

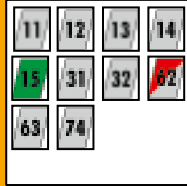

K413TC-3

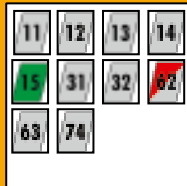

K313TC-3

K413TC-3



NEW

NEW



6HX

6HX

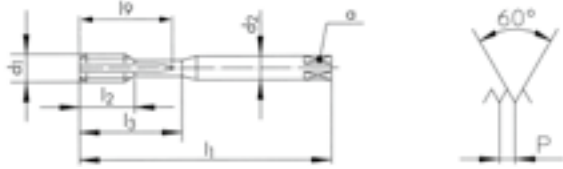

∅ d ₁ MF	P mm	l ₁ mm	l ₂ mm	l ₃ mm	l ₄ mm	d ₂ mm	a mm	3	4
10	1.00	100	22.0	39	37	10.0	8.0	3	9.00
12	1.00	110	24.0		42	9.0	7.0	3	11.00
12	1.25	110	24.0		42	9.0	7.0	3	10.80
12	1.50	110	24.0		42	9.0	7.0	3	10.50
14	1.50	110	28.0		49	11.0	9.0	3	12.50
16	1.50	110	30.0		56	12.0	9.0	3	14.50
20	1.50	140	36.0		70	16.0	12.0	5	18.50

ID

ID

175729

175731

175733

175735

175737

175739

171205

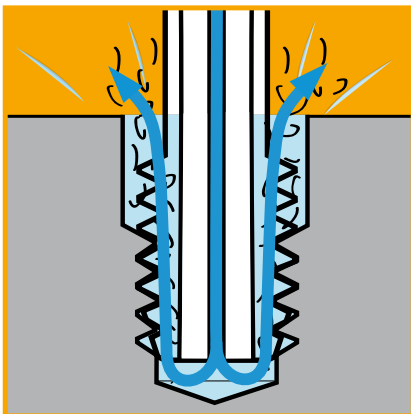

FPS FORMING

FPS381CN-3

FPS381VS-3

FPS481VS-3

FPS381CN-3 **FPS381VS-3** **FPS481VS-3**

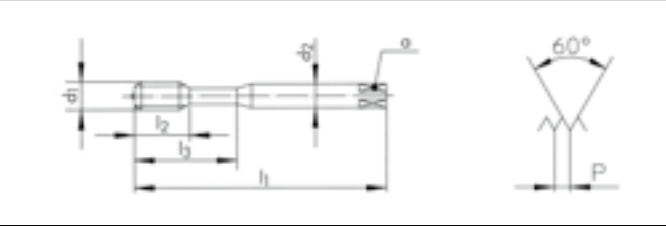
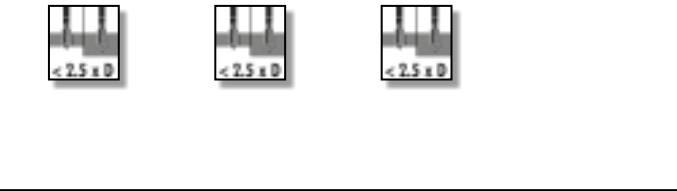

6HX **6HX** **6HX**

∅ d ₁ MF	P mm	l ₁ mm	l ₂ mm	l ₃ mm	d ₂ mm	a mm	6HX Tol. → ←
4	0.50	63	14.0	21	4.5	3.4	3.80 + 0.03
5	0.50	70	15.0	25	6.0	4.9	4.80 + 0.03
6	0.50	80	17.0	30	6.0	4.9	5.80 + 0.03
6	0.75	80	17.0	30	6.0	4.9	5.65 + 0.03
8	0.75	90	20.0	35	8.0	6.2	7.65 + 0.03
8	1.00	90	20.0	35	8.0	6.2	7.55 + 0.05
10	1.00	100	22.0	39	10.0	8.0	9.55 + 0.05
12	1.00	100	19.0		9.0	7.0	11.55 + 0.05
14	1.50	100	24.0		11.0	9.0	13.30 + 0.05
16	1.50	100	26.0		12.0	9.0	15.30 + 0.05

ID	ID	ID
	166631	
	166639	
	166699	
166648	166649	
166701	166702	
166658	166659	
166668	166669	
		166674
		166679
		166684

FAS FORMING

FAS381VS-3



VS

12	13	14	15
21	22	23	24
41	51	61	63

FAS481VS-3



VS

12	13	14	15
21	22	23	24
41	51	61	63

FAS381VS-3

FAS481VS-3

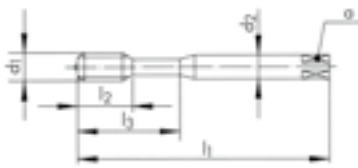

6HX

6HX

∅ d ₁ MF	P mm	l ₁ mm	l ₂ mm	l ₃ mm	d ₂ mm	a mm	6HX Tol. → ←
4	0.50	63	14.0	21	4.5	3.4	3.80 + 0.03
5	0.50	70	15.0	25	6.0	4.9	4.80 + 0.03
6	0.50	80	17.0	30	6.0	4.9	5.80 + 0.03
6	0.75	80	17.0	30	6.0	4.9	5.65 + 0.03
8	0.75	90	20.0	35	8.0	6.2	7.65 + 0.03
8	1.00	90	20.0	35	8.0	6.2	7.55 + 0.05
10	1.00	100	22.0	39	10.0	8.0	9.55 + 0.05
12	1.00	100	19.0		9.0	7.0	11.55 + 0.05
14	1.50	100	24.0		11.0	9.0	13.30 + 0.05
16	1.50	100	26.0		12.0	9.0	15.30 + 0.05

ID

ID

166625

166633

166698

166642

166700

166652

166662

166672

166677

166682

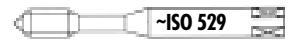

										N1110-1	N1110-3	N1110-S	
N1110-1													
N1110-3													
N1110-S													
Ø d ₁ MF	P mm	l ₁ mm	l ₂ mm	l ₃ mm	d ₂ mm	a mm				ID	ID	ID	
2	0.25	45	8.0		2.80	2.10	3	1.75			102933		
2.2	0.25	45	9.5		2.80	2.10	3	1.95			102936		
2.3	0.25	45	9.5		2.80	2.10	3	2.05			* 102938		
2.5	0.35	45	9.5		2.80	2.10	3	2.15			102940		
3	0.35	48	11.0	18	3.15	2.50	3	2.65			102945		
3.5	0.35	50	13.0	20	3.55	2.80	3	3.15			102949		
4	0.35	53	13.0	21	4.00	3.15	3	3.65			102952		
4	0.50	53	13.0	21	4.00	3.15	3	3.50		102773	102953	111040	
4.5	0.50	53	13.0	21	4.50	3.55	3	4.00			102958		
5	0.35	58	16.0	25	5.00	4.00	3	4.65			102960		
5	0.50	58	16.0	25	5.00	4.00	3	4.50		102778	102961	111045	
5	0.75	58	16.0	25	5.00	4.00	3	4.25			102963		
5.5	0.50	62	17.0	26	5.60	4.50	3	5.00			102967		
6	0.50	66	19.0	30	6.30	5.00	3	5.50		102783	102969	111050	
6	0.75	66	19.0	30	6.30	5.00	3	5.25		102784	102971	111051	
7	0.50	66	19.0	30	7.10	5.60	3	6.50			102975		
8	0.75	72	22.0	35	8.00	6.30	3	7.25		102790	102982	111057	
8	1.00	72	22.0	35	8.00	6.30	3	7.00		102791	102984	111058	
9	0.50	72	22.0	36	9.00	7.10	3	8.50			102988		
9	0.75	72	22.0	36	9.00	7.10	3	8.25			102989		
9	1.00	72	22.0	36	9.00	7.10	3	8.00			102990		
10	0.50	80	24.0	39	10.00	8.00	3	9.50			102925		
10	1.00	80	24.0	39	10.00	8.00	3	9.00		102756	102928	111024	
10	1.25	80	24.0	39	10.00	8.00	3	8.80		102758	102930	111025	

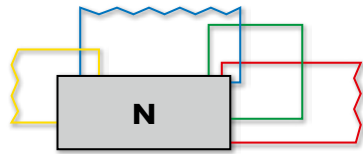

N1210-1

N1210-3

N1210-S

N1210-1

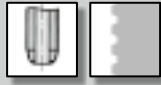

N1210-3

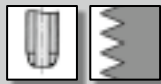

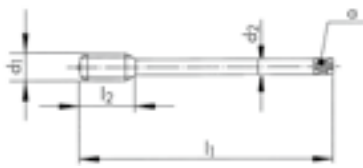

N1210-S



ISO 2
6H

ISO 2
6H

$\varnothing d_1$ MF	P mm	l_1 mm	l_2 mm	d_2 mm	a mm		
11	0.50	85	22.0	8.0	6.3	3	10.50
11	0.75	85	22.0	8.0	6.3	3	10.25
11	1.00	85	22.0	8.0	6.3	3	10.00
11	1.25	85	22.0	8.0	6.3	3	9.80
12	0.50	89	24.0	9.0	7.1	3	11.50
12	0.75	89	24.0	9.0	7.1	3	11.25
12	1.00	89	24.0	9.0	7.1	3	11.00
12	1.25	89	24.0	9.0	7.1	3	10.80
12	1.50	89	24.0	9.0	7.1	3	10.50
14	0.50	95	24.0	11.2	9.0	3	13.50
14	0.75	95	24.0	11.2	9.0	3	13.25
14	1.00	95	24.0	11.2	9.0	3	13.00
14	1.25	95	24.0	11.2	9.0	3	12.80
14	1.50	95	24.0	11.2	9.0	3	12.50
15	0.75	90	23.0	11.2	9.0	3	14.25
15	1.00	90	23.0	11.2	9.0	3	14.00
16	0.50	102	32.0	12.5	10.0	4	15.50
16	0.75	102	32.0	12.5	10.0	4	15.25
16	1.00	102	32.0	12.5	10.0	4	15.00
16	1.50	102	32.0	12.5	10.0	4	14.50
17	1.00	95	23.0	12.5	10.0	4	16.00
18	0.75	112	30.0	14.0	11.2	4	17.25
18	1.00	112	30.0	14.0	11.2	4	17.00
18	1.50	112	30.0	14.0	11.2	4	16.50
18	2.00	112	30.0	14.0	11.2	3	16.00
19	1.00	112	33.0	14.0	11.2	4	18.00

ID

ID

ID

103485

103486

103487

103488

103490

103491

103305

103493

111169

103307

103495

111171

103308

103497

111172

103502

103503

103312

103504

111175

103314

103506

111177

103315

103508

111178

103512

103513

103515

103516

103321

103517

111183

103322

103520

111184

103525

103527

103326

103528

111187











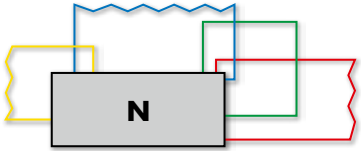

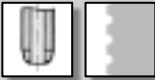

103327

103531

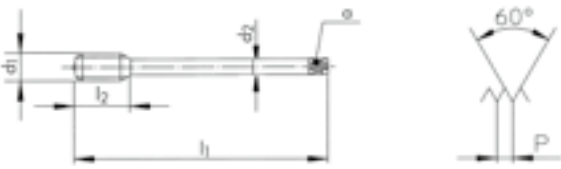
111188

103533







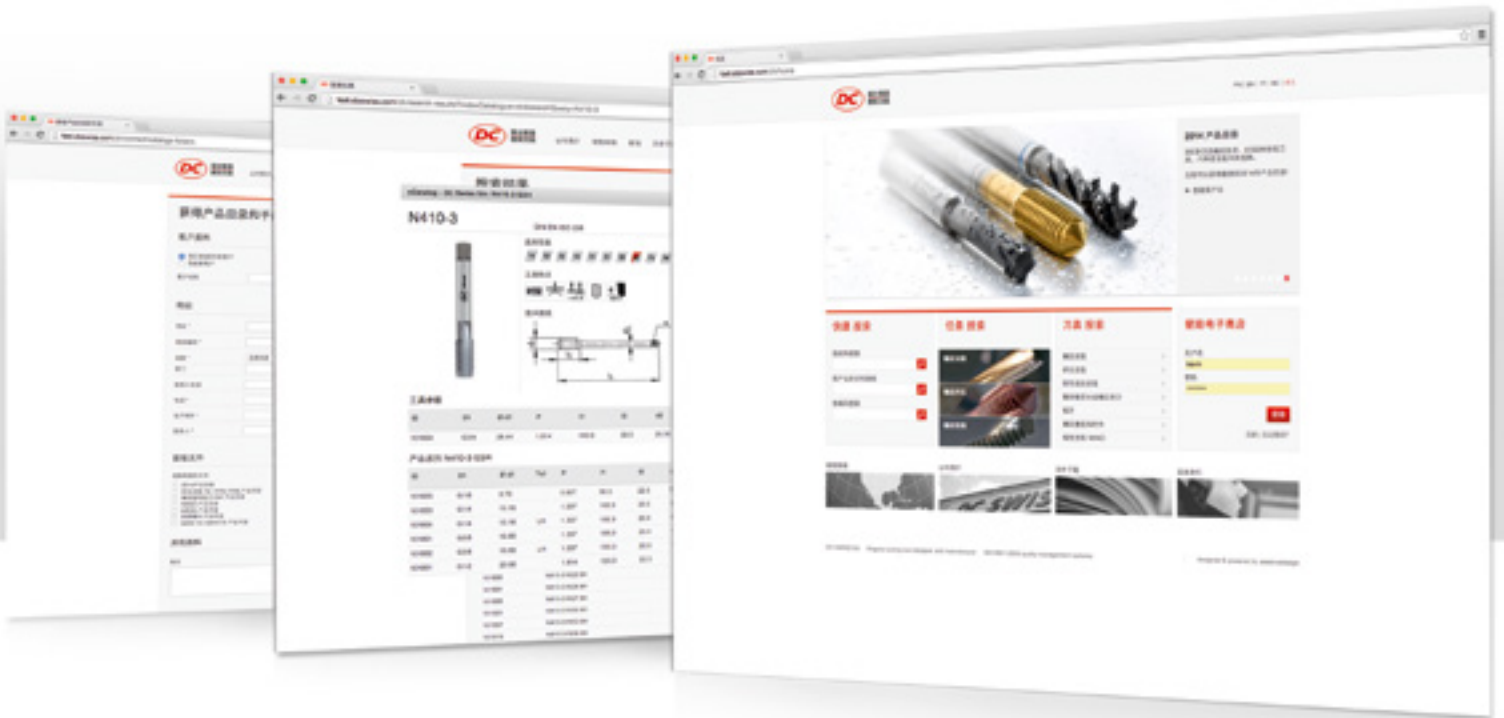



















103536

									N1210-1	N1210-3	N1210-S			
														
N1210-1														
N1210-3														
N1210-S														
														
														
∅ d ₁ MF	P mm	l ₁ mm	l ₂ mm	d ₂ mm	a mm			ID	ID	ID				
20	1.00	112	37.0	14.0	11.2	4	19.00	103332	103537	111198				
20	1.25	112	37.0	14.0	11.2	4	18.80		103539					
20	1.50	112	37.0	14.0	11.2	4	18.50	103334	103540	111195				
22	1.00	115	32.0	16.0	12.5	4	21.00		103545					
22	1.50	115	32.0	16.0	12.5	4	20.50	103340	103546	121669				
22	2.00	115	32.0	16.0	12.5	3	20.00		103548					
24	1.00	120	30.0	18.0	14.0	4	23.00		103552					
24	1.50	120	30.0	18.0	14.0	4	22.50	103343	103553	111202				
24	2.00	130	45.0	18.0	14.0	4	22.00	103344	103555	111203				
25	1.00	120	30.0	18.0	14.0	4	24.00		103559					
25	1.50	120	30.0	18.0	14.0	4	23.50		103560					
25	2.00	120	30.0	18.0	14.0	4	23.00		103561					
26	1.00	120	30.0	18.0	14.0	4	25.00		103562					
26	1.50	120	30.0	18.0	14.0	4	24.50	103346	103563	111207				
26	2.00	120	30.0	18.0	14.0	4	24.00		103564					
27	1.00	127	30.0	20.0	16.0	4	26.00		103565					
27	1.50	127	30.0	20.0	16.0	4	25.50		103566					
27	2.00	135	45.0	20.0	16.0	4	25.00	* 103351	* 103567	* 111210				
28	1.00	127	30.0	20.0	16.0	4	27.00		103570					
28	1.50	127	30.0	20.0	16.0	4	26.50		103571					
30	1.50	127	32.0	20.0	16.0	4	28.50	103355	103575	111214				
30	2.00	127	32.0	20.0	16.0	4	28.00	103356	103577	111215				

更准确
更个性化
更方便快捷

































DCSWISS.COM

		N					Z	
特点 Characteristics				 V	 R40 V	 	 V	 VS
					 	  		
洞型 Hole type								
		N310-3	N320-3 N320-4	N320V-4	N360-3 N360V-3	N1110 -1-2-3-S	Z320V-3 Z320V-4	Z320VS-4
DIN 标准 长型 DIN long	DIN 371	114	114	114	116		118	118
ISO 标准 短型 ISO short	ISO 529					128		
公差 Tolerance	UNC 2B	114	114	114	116	128	118	118
公差 Tolerance	UNC 3B							
公差 Tolerance	UNC(J) 3B		114		116			
		N410-3	N420-4	N420V-4	N460-3 N460V-3	N1210 -1-2-3-S	Z420V-4	Z420VS-4
DIN 标准 长型 DIN long	DIN 376	115	115	115	117		118	118
ISO 标准 短型 ISO short	ISO 529					129		
公差 Tolerance	UNC 2B	115	115	115	117	129	118	118
公差 Tolerance	UNC 3B							
公差 Tolerance	UNC(J) 3B							

Z		H		S		SA		
								
								
								
								
Z360V-3 Z362V-3	Z370VS-3	H320-4	H350-3	S320VS-4	S360VS-3	SA320-4	SA350-3	SA390-3
119	120	121	121	122	123	124	124	125
119	120	121	121	122	123	124	124	
	120			122		124	124	125
Z462V-3	Z470VS-3	H420-4	H450-3	S420VS-4	S460VS-3	SA420-4	SA450-3	
119	120	121	121	122	123	125	125	
119	120	121	121	122	123	125	125	



	TL		RTS		FS	FPS	FAS
特点 Characteristics							
							
							
洞型 Hole type							
	TL320VS-4	TL351VS-3			FS380VS-3	FPS381VS-3	FAS381VS-3
DIN 标准 长型 DIN long	DIN 371						
	124	124	126	126			
DIN 标准 长型 DIN long	~ DIN 2184-1						
					127	127	127
公差 Tolerance	UNC 2B						
	124	124	126	126	127	127	127
公差 Tolerance	UNC 3B						
公差 Tolerance	UNC(J) 3B						
	124	124					
							
DIN 标准 长型 DIN long	DIN 376						
			126	126			
DIN 标准 长型 DIN long	~ DIN 2184-1						
公差 Tolerance	UNC 2B						
			126	126			
公差 Tolerance	UNC 3B						
公差 Tolerance	UNC(J) 3B						

aero

THREADING TOOLS FOR AEROSPACE MATERIALS

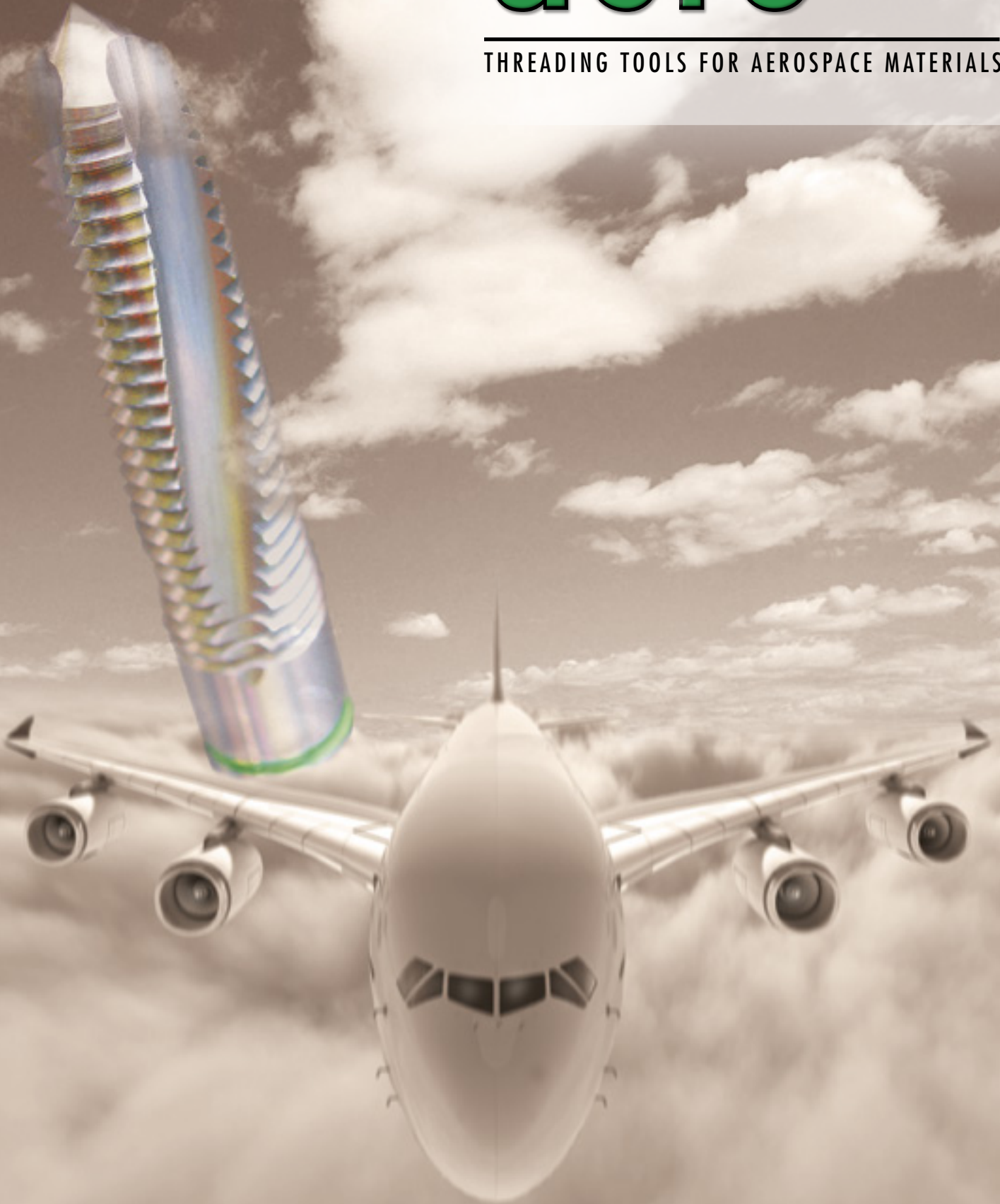











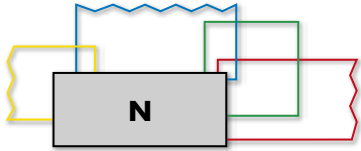

UNC ANSI B1.1

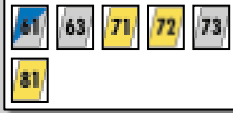
≤ Ø 2.8 > Ø 2.8

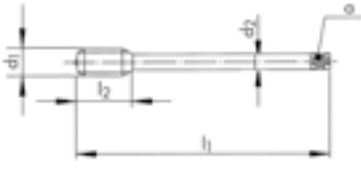
PM **HSSE**



										N310-3	N320-4	N320V-4	
N310-3													
N320-4													
N320V-4	V												
Ø" d ₁ UNC	P TPI	d ₁ mm	l ₁ mm	l ₂ mm	l ₃ mm	d ₂ mm	a mm			ID	ID	ID	
*2	56	2.18	45	9.0		2.8	2.1	2	1.75		101469	143690	
*3	48	2.51	50	10.0		2.8	2.1	2	2.00		101470		
4	40	2.84	56	12.0	18	3.5	2.7	3	2.25	101450	101511	142738	
5	40	3.17	56	12.0	18	3.5	2.7	3	2.55		101512		
6	32	3.50	56	13.0	20	4.0	3.0	3	2.75	101451	101514	144402	
8	32	4.16	63	14.0	21	4.5	3.4	3	3.40	101452	101515	142739	
10	24	4.82	70	15.0	25	6.0	4.9	3	3.80	101449	101508	142740	
12	24	5.48	80	17.0	30	6.0	4.9	3	4.40		101509		
1/4	20	6.35	80	17.0	30	7.0	5.5	3	5.10	101448	101507	142741	
Ø" d ₁ UNC	P TPI	d ₁ mm	l ₁ mm	l ₂ mm	l ₃ mm	d ₂ mm	a mm			ID	ID	ID	
4	40	2.84	56	12.0	18	3.5	2.7	3	2.30		145656		
6	32	3.50	56	13.0	20	4.0	3.0	3	2.80		155317		
8	32	4.16	63	14.0	21	4.5	3.4	3	3.45		155319		
* N320-3													

										N410-3	N420-4	N420V-4
										N410-3		
N420-4												
N420V-4	 V											
 												
										2B	2B	2B
\varnothing " d ₁	P	d ₁	l ₁	l ₂	d ₂	a				ID	ID	ID
UNC	TPI	mm	mm	mm	mm	mm						
5/16	18	7.93	90	20.0	6.0	4.9	3	6.50		101997	102213	142742
3/8	16	9.52	100	22.0	7.0	5.5	3	8.00		101996	102212	142743
7/16	14	11.11	100	19.0	8.0	6.2	3	9.30			102215	142744
1/2	13	12.70	110	24.0	9.0	7.0	3	10.80		101993	102208	142745
9/16	12	14.28	110	28.0	11.0	9.0	3	12.20			102217	
5/8	11	15.87	110	30.0	12.0	9.0	3	13.60		101998	102214	142746
3/4	10	19.05	125	33.0	14.0	11.0	3	16.60		101995	102211	142747
7/8	9	22.22	140	36.0	18.0	14.5	3	19.50			102216	142748
1	8	25.40	160	39.0	18.0	14.5	4	22.30		101994	102209	142749
1 1/8	7	28.57	180	45.0	22.0	18.0	4	25.00			102205	
1 1/4	7	31.75	180	45.0	22.0	18.0	4	28.20		* 101991	102204	
1 1/2	6	38.10	200	55.0	32.0	24.0	4	34.00		* 101990	102203	
1 3/4	5	44.45	220	59.0	36.0	29.0	4	39.50		* 101992	102206	
2	4.5	50.80	250	67.0	40.0	32.0	4	45.30			102210	

UNC ANSI B1.1

≤ Ø 2.8 > Ø 2.8

PM HSSE

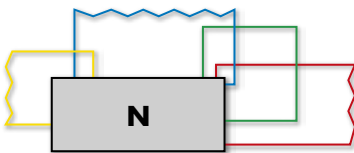

N360-3

N360V-3

N360-3



N360-3



61	63	71	72	73
81				

N360V-3



11	12	13	14	21
32				

N360-3



61	63	71	72	73
81				

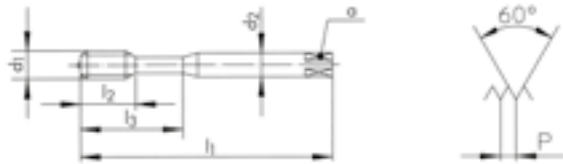









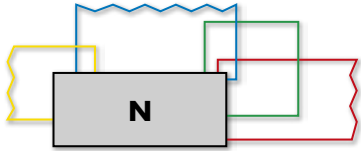

2B

2B

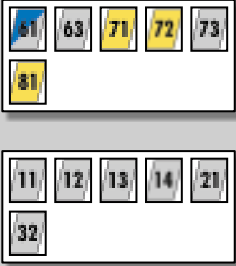
3B
UNC(J)

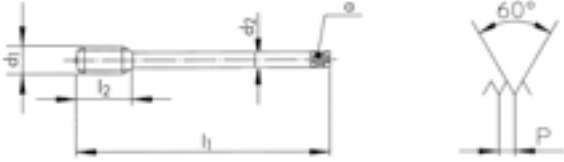
Ø" d ₁ UNC	P TPI	d ₁ mm	l ₁ mm	l ₂ mm	l ₃ mm	d ₂ mm	a mm			ID	ID	ID
2	56	2.18	45	8.0		2.8	2.1	2	1.75	101673	148887	
3	48	2.51	50	9.0		2.8	2.1	2	2.00	101674		
4	40	2.84	56	5.5	18	3.5	2.7	3	¹ 2.25	101676	101725	155316
5	40	3.17	56	5.5	18	3.5	2.7	3	2.55	101677		
6	32	3.50	56	6.5	20	4.0	3.0	3	² 2.75	101679	101727	155318
8	32	4.16	63	7.5	21	4.5	3.4	3	³ 3.40	101680	101728	155320
10	24	4.82	70	9.0	25	6.0	4.9	3	3.80	101671	101723	
12	24	5.48	80	11.0	30	6.0	4.9	3	4.40	101672		
1/4	20	6.35	80	11.0	30	7.0	5.5	3	5.10	101670	101722	
5/16	18	7.93	90	12.5	35	8.0	6.2	3	6.50	101678	101726	
3/8	16	9.52	100	14.0	39	10.0	8.0	3	8.00	101675	101724	











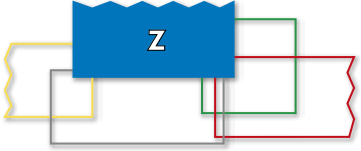







UNJC
¹2.30
²2.80
³3.45

										N460-3	N460V-3						
																	
<p>N460-3</p>   																	
																	
$\varnothing'' d_1$ UNC	P TPI	d_1 mm	l_1 mm	l_2 mm	d_2 mm	a mm			$\rightarrow \leftarrow$	ID	ID						
7/16	14	11.11	100	14.0	8.0	6.2	3	9.30		102424	105135						
1/2	13	12.70	110	14.0	9.0	7.0	3	10.80		102420	102497						
9/16	12	14.28	110	14.0	11.0	9.0	3	12.20		102426	102502						
5/8	11	15.87	110	18.0	12.0	9.0	3	13.60		102423	102500						
3/4	10	19.05	125	21.0	14.0	11.0	3	16.60		102422	102499						
7/8	9	22.22	140	24.0	18.0	14.5	4	19.50		102425	102501						
1	8	25.40	160	27.0	18.0	14.5	4	22.30		102421	102498						
1 1/8	7	28.57	180	30.0	22.0	18.0	4	25.00		102418	102495						
1 1/4	7	31.75	180	30.0	22.0	18.0	4	28.20		102417	102494						
1 1/2	6	38.10	200	40.0	32.0	24.0	5	34.00		102416	102493						
1 3/4	5	44.45	220	44.0	36.0	29.0	5	39.50			128062						
2	4.5	50.80	250	52.0	40.0	32.0	5	45.30			128084						

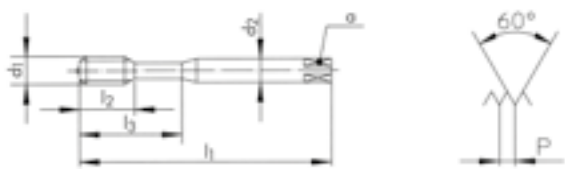
										Z320V-4	Z320VS-4	Z420V-4	Z420VS-4
										Z320V-4		V	21 22 23 41 42 51
Z320VS-4		VS	21 22 23 24 51 61										
Z420V-4		V	21 22 23 41 42 51										
Z420VS-4		VS	21 22 23 24 51 61										
										2B	2B	2B	2B
\varnothing d ₁ UNC	P TPI	d ₁ mm	l ₁ mm	l ₂ mm	l ₃ mm	d ₂ mm	a mm			ID	ID	ID	ID
*2	56	2.18	45	9.0		2.8	2.1	2	1.75	142750			
4	40	2.84	56	12.0	18	3.5	2.7	3	2.25	142751			
6	32	3.50	56	13.0	20	4.0	3.0	3	2.75	142752	111560		
8	32	4.16	63	14.0	21	4.5	3.4	3	3.40	142753	111561		
10	24	4.82	70	15.0	25	6.0	4.9	3	3.80	142754	111562		
1/4	20	6.35	80	17.0	30	7.0	5.5	3	5.10	142755	111563		
5/16	18	7.93	90	20.0	35	8.0	6.2	3	6.50	142756	111564		
3/8	16	9.52	100	22.0	39	10.0	8.0	3	8.00	142757	111565		
1/2	13	12.70	110	24.0		9.0	7.0	3	10.80			142758	111566
5/8	11	15.87	110	30.0		12.0	9.0	3	13.60			142759	111567
3/4	10	19.05	125	33.0		14.0	11.0	4	16.60			142760	111568
7/8	9	22.22	140	36.0		18.0	14.5	4	19.50			142761	
1	8	25.40	160	39.0		18.0	14.5	4	22.30			142762	

* Z320V-3



										Z362V-3	Z362VS-3	Z462V-3	
										Z362V-3 			
Z362VS-3 													
Z462V-3 													
													
Ø" d ₁ UNC P TPI d ₁ mm l ₁ mm l ₂ mm l ₃ mm d ₂ mm a mm  	ID	ID	ID										
*2	56	2.18	45	8.0		2.8	2.1	2	1.75	104695			
*4	40	2.84	56	5.5	18	3.5	2.7	3	2.25	104697			
6	32	3.50	56	6.5	20	4.0	3.0	3	2.75	104699	* 111543		
8	32	4.16	63	7.5	21	4.5	3.4	3	3.40	104700	* 111544		
10	24	4.82	70	9.0	25	6.0	4.9	3	3.80	104694			
1/4	20	6.35	80	11.0	30	7.0	5.5	3	5.10	104693			
5/16	18	7.93	90	12.5	35	8.0	6.2	3	6.50	104698			
3/8	16	9.52	100	14.0	39	10.0	8.0	3	8.00	104696	* 111548		
7/16	14	11.11	100	14.0		8.0	6.2	3	9.30			104757	
1/2	13	12.70	110	14.0		9.0	7.0	3	10.80			104753	
5/8	11	15.87	110	18.0		12.0	9.0	3	13.60			104756	
3/4	10	19.05	125	21.0		14.0	11.0	3	16.60			104755	
7/8	9	22.22	140	24.0		18.0	14.5	3	19.50			104758	
1	8	25.40	160	27.0		18.0	14.5	4	22.30			104754	

* Z360V-3

										Z370VS-3	Z470VS-3		
<p>Z370VS-3</p>													
<p>Z470VS-3</p>													
Ø" d ₁ UNC	P TPI	d ₁ mm	l ₁ mm	l ₂ mm	l ₃ mm	d ₂ h ₆ mm	a mm			ID	ID		
6	32	3.50	56	6.5	20	4.0(h9)	3.0	3	2.75	166123			
8	32	4.16	63	7.5	21	4.5(h9)	3.4	3	3.40	166124			
10	24	4.82	70	9.0	25	6.0	4.9	3	3.80	166125			
1/4	20	6.35	80	11.0	30	*6.0	*4.9	3	5.10	166126			
5/16	18	7.93	90	12.5	35	8.0	6.2	3	6.50	166127			
3/8	16	9.52	100	14.0	39	10.0	8.0	3	8.00	166128			
7/16	14	11.11	100	14.0		8.0	6.2	3	9.30		166129		
1/2	13	12.70	110	14.0		*10.0	*8.0	4	10.80		166130		
5/8	11	15.87	110	18.0		12.0	9.0	4	13.60		166131		
3/4	10	19.05	125	21.0		14.0	11.0	4	16.60		166132		
1	8	25.40	160	27.0		16.0	12.0	4	22.30		175703		
* DC 标准 / * DC Norm													
Ø" d ₁ UNC	P TPI	d ₁ mm	l ₁ mm	l ₂ mm	l ₃ mm	d ₂ h ₆ mm	a mm			ID			
4	40	2.84	56	5.5	18	3.5(h9)	2.7	3	2.30	165114			
6	32	3.50	56	6.5	20	4.0(h9)	3.0	3	2.80	165115			
8	32	4.16	63	7.5	21	4.5(h9)	3.4	3	3.45	165116			
1/4	20	6.35	80	11.0	30	*6.0	*4.9	3	5.20	165117			
5/16	18	7.93	90	12.5	35	8.0	6.2	3	6.70	165118			
* DC 标准 / * DC Norm													

UNC ANSI B1.1

PM

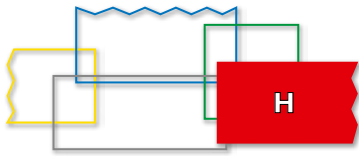
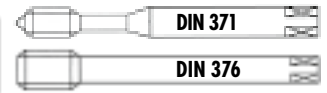

H320-4		
H420-4		
H350-3		
H450-3		

H320-4	H420-4	H350-3	H450-3
--------	--------	--------	--------



--	--	--	--

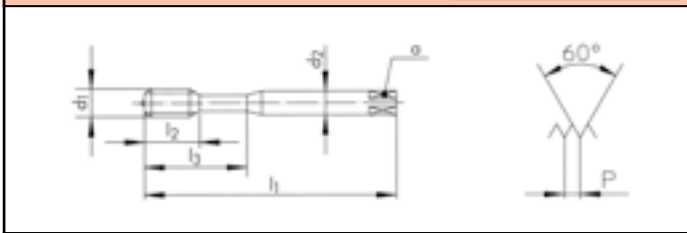

2B	2B	2B	2B

Ø" d ₁ UNC	P TPI	d ₁ mm	l ₁ mm	l ₂ mm	l ₃ mm	d ₂ mm	a mm		
2	56	2.18	45	8.0		2.8	2.1	2	1.75
4	40	2.84	56	10.0	18	3.5	2.7	3	2.25
6	32	3.50	56	13.0	20	4.0	3.0	3	2.75
8	32	4.16	63	14.0	21	4.5	3.4	3	3.40
10	24	4.82	70	15.0	25	6.0	4.9	3	3.80
1/4	20	6.35	80	17.0	30	7.0	5.5	3	5.10
5/16	18	7.93	90	20.0	35	8.0	6.2	3	6.50
3/8	16	9.52	100	22.0	39	10.0	8.0	3	8.00
1/2	13	12.70	110	24.0		9.0	7.0	4	10.80

ID	ID
101221	
101223	
101225	
101226	
101220	
101219	
101224	
101222	
	101290

Ø" d ₁ UNC	P TPI	d ₁ mm	l ₁ mm	l ₂ mm	l ₃ mm	d ₂ mm	a mm		
2	56	2.18	45	8.0		2.8	2.1	2	1.75
4	40	2.84	56	5.5	18	3.5	2.7	3	2.25
6	32	3.50	56	6.5	20	4.0	3.0	3	2.75
8	32	4.16	63	7.5	21	4.5	3.4	3	3.40
10	24	4.82	70	9.0	25	6.0	4.9	3	3.80
1/4	20	6.35	80	11.0	30	7.0	5.5	3	5.10
5/16	18	7.93	90	12.5	35	8.0	6.2	3	6.50
3/8	16	9.52	100	14.0	39	10.0	8.0	3	8.00
7/16	14	11.11	100	14.0		8.0	6.2	3	9.30
1/2	13	12.70	110	14.0		9.0	7.0	4	10.80
5/8	11	15.87	110	18.0		12.0	9.0	4	13.60
3/4	10	19.05	125	21.0		14.0	11.0	4	16.60
1	8	25.40	160	27.0		18.0	14.5	4	22.30

ID	ID
	101258
	101260
	101262
	101263
	101257
	101256
	101261
	101259
	101330
	101326
	101329
	101328
	101327

										S320VS-4	S420VS-4		
<p>S320VS-4 </p> <p>S420VS-4 </p>													
\varnothing d ₁ UNC	P TPI	d ₁ mm	l ₁ mm	l ₂ mm	l ₃ mm	d ₂ mm	a mm			ID	ID		
6	32	3.50	56	13.0	20	4.0	3.0	3	2.75	111587			
8	32	4.16	63	14.0	21	4.5	3.4	3	3.40	111588			
10	24	4.82	70	15.0	25	6.0	4.9	3	3.80	* 111589			
1/4	20	6.35	80	17.0	30	7.0	5.5	3	5.10	111590			
5/16	18	7.93	90	20.0	35	8.0	6.2	3	6.50	111591			
3/8	16	9.52	100	22.0	39	10.0	8.0	3	8.00	111592			
1/2	13	12.70	110	24.0		9.0	7.0	4	10.80		111593		
5/8	11	15.87	110	30.0		12.0	9.0	4	13.60		111594		
3/4	10	19.05	125	33.0		14.0	11.0	4	16.60		111595		
\varnothing d ₁ UNC	P TPI	d ₁ mm	l ₁ mm	l ₂ mm	l ₃ mm	d ₂ mm	a mm			ID			
4	40	2.84	56	12.0	18	3.5	2.7	3	2.30	165314			
6	32	3.50	56	13.0	20	4.0	3.0	3	2.80	165315			
8	32	4.16	63	14.0	21	4.5	3.4	3	3.45	165316			
1/4	20	6.35	80	17.0	30	7.0	5.5	3	5.20	165317			
5/16	18	7.93	90	20.0	35	8.0	6.2	3	6.70	* 143761			

											S360VS-3	S460VS-3		
											<p>S360VS-3 </p> <p>S460VS-3 </p>			
\varnothing " d ₁ UNC	P TPI	d ₁ mm	l ₁ mm	l ₂ mm	l ₃ mm	d ₂ mm	a mm				ID	ID		
6	32	3.50	56	6.5	20	4.0	3.0	3	2.75		111530			
8	32	4.16	63	7.5	21	4.5	3.4	3	3.40		111531			
10	24	4.82	70	9.0	25	6.0	4.9	3	3.80		* 111532			
1/4	20	6.35	80	11.0	30	7.0	5.5	3	5.10		111533			
5/16	18	7.93	90	12.5	35	8.0	6.2	3	6.50		111534			
3/8	16	9.52	100	14.0	39	10.0	8.0	3	8.00		111535			
1/2	13	12.70	110	14.0		9.0	7.0	4	10.80			111537		
3/4	10	19.05	125	21.0		14.0	11.0	4	16.60			* 111539		

aero

										SA320-4	SA350-3	TL320VS-4	TL351VS-3
<div style="display: flex; justify-content: space-between;"> <div style="width: 45%;"> <p>SA320-4 52 53</p> <p>SA350-3 52 53</p> <p>TL320VS-4 VS 41 42</p> <p>TL351VS-3 VS 41 42</p> </div> <div style="width: 45%; text-align: center;"> </div> </div>													
										<div style="display: flex; justify-content: space-around;"> <div style="border: 1px solid black; padding: 5px;">2B</div> <div style="border: 1px solid black; padding: 5px;">2B</div> <div style="border: 1px solid black; padding: 5px;">2B</div> <div style="border: 1px solid black; padding: 5px;">2B</div> </div>			
$\varnothing'' d_1$ UNC	P TPI	d_1 mm	l_1 mm	l_2 mm	l_3 mm	d_2 mm	a mm			ID	ID	ID	ID
4	40	2.84	56	12.0		3.5	2.7	3	2.25	147271	149003		152018
5	40	3.17	56	12.0		3.5	2.7	3	2.55	* 149031	* 149033	* 152023	* 152024
6	32	3.50	56	13.0		4.0	3.0	3	2.75	149055	149057	* 152027	152028
8	32	4.16	63	14.0		4.5	3.4	3	3.40	149093	149095	* 152036	152037
10	24	4.82	70	15.0		6.0	4.9	3	3.80	149125	* 149127	* 152042	* 152043
1/4	20	6.35	80	15.0	23	7.0	5.5	3	5.10	149222	149224	* 152062	127972
5/16	18	7.93	90	18.0	29	8.0	6.2	3	6.50	149269	149271		152068
3/8	16	9.52	100	20.0	33	10.0	8.0	3	8.00	149346	149348	* 152084	152085
										<div style="display: flex; justify-content: space-around;"> <div style="border: 1px solid black; padding: 5px;">3B UNC(J)</div> <div style="border: 1px solid black; padding: 5px;">3B UNC(J)</div> <div style="border: 1px solid black; padding: 5px;">3B UNC(J)</div> <div style="border: 1px solid black; padding: 5px;">3B UNC(J)</div> </div>			
$\varnothing'' d_1$ UNC	P TPI	d_1 mm	l_1 mm	l_2 mm	l_3 mm	d_2 mm	a mm			ID	ID	ID	ID
4	40	2.84	56	12.0		3.5	2.7	3	2.30	149005	149007	* 148804	150194
6	32	3.50	56	13.0		4.0	3.0	3	2.80	149059	149061	* 152029	150210
8	32	4.16	63	14.0		4.5	3.4	3	3.45	149097	149099	* 152038	152039
10	24	4.82	70	15.0		6.0	4.9	3	3.90	* 149129	* 149131		* 152045
1/4	20	6.35	80	15.0	23	7.0	5.5	3	5.20	149226	149228	* 152063	152064
5/16	18	7.93	90	18.0	29	8.0	6.2	3	6.70	149273	149275	* 152069	152070
3/8	16	9.52	100	20.0	33	10.0	8.0	3	8.10	149350	149352	* 152086	152087

aero

SA420-4

SA450-3

SA390-3

SA420-4



SA450-3



SA390-3

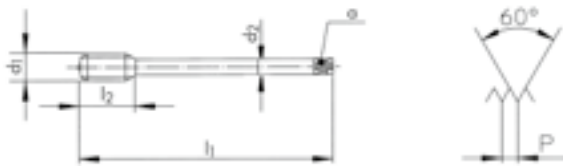

$\varnothing'' d_1$ UNC	P TPI	d_1 mm	l_1 mm	l_2 mm	d_2 mm	a mm		
7/16	14	11.11	100	22.0	8.0	6.2	3	9.30
1/2	13	12.70	110	24.0	9.0	7.0	4	10.80
5/8	11	15.87	110	30.0	12.0	9.0	4	13.60
3/4	10	19.05	125	33.0	14.0	11.0	4	16.60

ID

ID

* 152246

152247

152252

152249

152254

* 152250

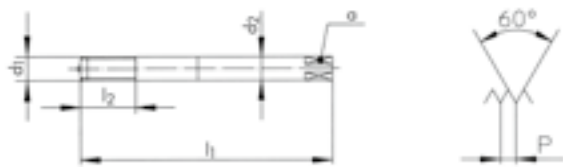

$\varnothing'' d_1$ UNC	P TPI	d_1 mm	l_1 mm	l_2 mm	d_2 mm	a mm		
4	40	2.84	56	12.0	3.5	2.7	3	2.30
6	32	3.50	56	13.0	4.0	3.0	3	2.80
8	32	4.16	63	14.0	4.5	3.4	3	3.45
10	24	4.82	70	15.0	6.0	4.9	3	3.90
1/4	20	6.35	80	20.0	7.0	5.5	3	5.20
5/16	18	7.93	90	25.0	8.0	6.2	3	6.70
3/8	16	9.52	100	30.0	10.0	8.0	3	8.10

3B
UNC(J)

ID

149652

149666

149677

149685

149713

149726

149747



只适用于刚性攻丝
Only for rigid tapping

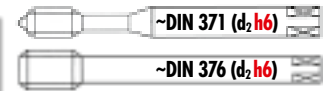

RTS Rigid Tapping Synchro

RTS320VS-4 **VS**

RTS420VS-4 **VS**

RTS362VS-3 **VS**

RTS462VS-3 **VS**

11	12	13	14
15	21	22	31
32	61	63	72
73	74		

RTS320VS-4	RTS420VS-4	RTS362VS-3	RTS462VS-3
------------	------------	------------	------------

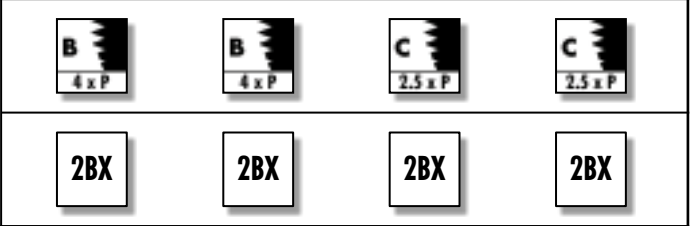
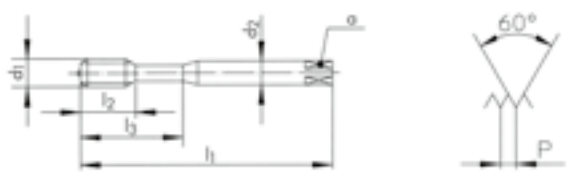
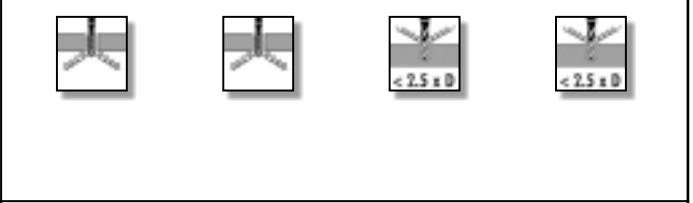

Ø" d ₁ UNC	P TPI	d ₁ mm	l ₁ mm	l ₂ mm	l ₃ mm	d ₂ h6 mm	α mm		
6	32	3.50	56	6.5	20	4.0(h9)	3.0	3	2.75
8	32	4.16	63	7.5	21	4.5(h9)	3.4	3	3.40
10	24	4.82	70	9.0	25	6.0	4.9	3	3.80
1/4	20	6.35	80	11.0	30	*6.0	*4.9	3	5.10
5/16	18	7.93	90	12.5	35	8.0	6.2	3	6.50
3/8	16	9.52	100	14.0	39	10.0	8.0	3	8.00
1/2	13	12.70	110	14.0		*10.0	*8.0	3	10.80

ID	ID	ID	ID
157395		157402	
157396		157403	
157397		157404	
157398		157405	
157399		157406	
157400		157407	
	157401		157408

* DC 标准 / * DC Norm



FS FPS FAS FORMING

FS380VS-3

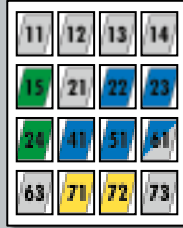

FPS381VS-3



FAS381VS-3

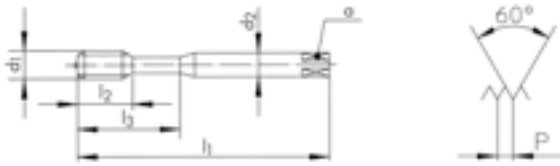

Ø" d ₁ UNC	P TPI	d ₁ mm	l ₁ mm	l ₂ mm	l ₃ mm	d ₂ mm	α mm	→ ← Tol.
2	56	2.18	45	9.0		2.8	2.1	1.95 + 0.02
4	40	2.84	56	12.0	18	3.5	2.7	2.55 + 0.03
6	32	3.50	56	13.0	20	4.0	3.0	3.15 + 0.03
8	32	4.16	63	14.0	21	4.5	3.4	3.80 + 0.03
10	24	4.82	70	15.0	25	6.0	4.9	4.35 + 0.05
1/4	20	6.35	80	17.0	30	7.0	5.5	5.75 + 0.05
5/16	18	7.93	90	20.0	35	8.0	6.2	7.30 + 0.05

FS380VS-3



FPS381VS-3



FAS381VS-3



2BX

2BX

2BX

ID

ID

ID

157285

170063
166713
166714
166715
166716
* 166717

170065
166725
166726
166727
166728
* 166729

										N1110-1	N1110-2	N1110-3	N1110-S	
										N1110-1				
N1110-2														
N1110-3														
N1110-S														
												2B	2B	
Ø" d ₁ UNC	P TPI	d ₁ mm	l ₁ mm	l ₂ mm	l ₃ mm	d ₂ mm	a mm			ID	ID	ID	ID	
2	56	2.18	45	9.5		2.80	2.10	3	1.75	102799	102885	102998	111067	
3	48	2.51	45	9.5		2.80	2.10	3	2.00	* 102800	* 102886	* 102999	* 111068	
4	40	2.84	48	11.0	18	3.15	2.50	3	2.25	102802	102888	103001	111070	
5	40	3.17	48	11.0	18	3.15	2.50	3	2.55			103002		
6	32	3.50	50	13.0	20	3.55	2.80	3	2.75	102805	102891	103004	111073	
8	32	4.16	53	13.0	21	4.50	3.55	3	3.40	102806	102892	103005	111074	
10	24	4.82	58	16.0	25	5.00	4.00	3	3.80	102797	102883	102996	111065	
1/4	20	6.35	66	19.0	30	6.30	5.00	3	5.10	102796	102882	102995	111064	
5/16	18	7.93	72	22.0	35	8.00	6.30	3	6.50	102804	102890	103003	111072	
3/8	16	9.52	80	24.0	39	10.00	8.00	3	8.00	102801	102887	103000	111069	

										N1210-1	N1210-2	N1210-3	N1210-S	
N1210-1														
N1210-2														
N1210-3														
N1210-S														
$\varnothing'' d_1$ UNC	P TPI	d_1 mm	l_1 mm	l_2 mm	d_2 mm	a mm			ϵ	ID	ID	ID	ID	
7/16	14	11.11	85	22.0	8.0	6.3	3	9.30		103392	103466	103606	111236	
1/2	13	12.70	89	24.0	9.0	7.1	3	10.80		103387	103461	103601	111229	
5/8	11	15.87	102	32.0	12.5	10.0	3	13.60		103391	103465	103605	111235	
3/4	10	19.05	112	33.0	14.0	11.2	3	16.60		103390	103464	103604	111234	
1	8	25.40	130	45.0	18.0	14.0	4	22.30		103388	103462	103602	111230	

UNF, UNEF, UNS, UN 目录 - 机用和手用丝锥 ANSI B1.1

Directory - Machine and hand taps ANSI B1.1





















		N						
特点 Characteristics				 V	 R40	 R40 V	 	
								
洞型 Hole type								
		N310-3	N320-3 N320-4	N320V-4	N360-3	N360V-3	N1110 -1-3-S	N1120-4
DIN 标准 长型 DIN long	DIN 371	134	134	134	136	136		
ISO 标准 短型 ISO short	ISO 529						148	150
公差 Tolerance	UNF 2B	134	134	134	136	136	148	
公差 Tolerance	UNJF 3B							
公差 Tolerance	UNF(J) 3B		134		136			
公差 Tolerance	UNEF 2B						150	150
公差 Tolerance	UNS 2B							
公差 Tolerance	UN 2B							
		N410-3	N420-4	N420V-4	N460-3	N460V-3	N1210 -1-3-S	N1220-4
DIN 标准 长型 DIN long	DIN 374	135/151	135	135	137	137		
ISO 标准 短型 ISO short	ISO 529						149	150
公差 Tolerance	UNF 2B	135	135	135	137	137	149	
公差 Tolerance	UNJF 3B							
公差 Tolerance	UNF(J) 3B		135		137			
公差 Tolerance	UNEF 2B						150	150
公差 Tolerance	UNS 2B	151			151	151		
公差 Tolerance	UN 2B				151	151		

UNF, UNJF

目录 - 机用丝锥 ANSI B1.1 / ASME B1.15
 Directory - Machine taps ANSI B1.1 / ASME B1.15

Z			H		S		SA	
								
V	V	VS			VS	VS		
								
								
Z320V-4	Z360V-3	Z370VS-3	H320-4	H350-3	S320VS-4	S360VS-3	SA320-4	SA320-4
138	138	139	140	141	142	142	143	145
138	138	139	140	141		142	143	145
		139			142	142	143	
Z420V-4	Z460V-3	Z470VS-3	H420-4	H450-3	S420VS-4	S460VS-3	SA420-4	
138	138	139	140	141	142	142	144	
138	138	139	140	141		142	144	
					142	142	144	

UNF, UNJF
 UNEF, UNS, UN

	SA		TL		RTS		
特点 Characteristics			 VS	  VS	 VS	 VS	
							
洞型 Hole type							
	SA350-3	SA390-3	TL320VS-4	TL351VS-3	RTS320VS-4	RTS362VS-3	
DIN 标准 长型 DIN long	DIN 371						
	143	145	143	143	146	146	
DIN 标准 长型 DIN long	~ DIN 2184-1						
公差 Tolerance	UNF 2B		143	143	146	146	
公差 Tolerance	UNF(J) 3B	143	145	143	143		
公差 Tolerance	UNEF 2B						
公差 Tolerance	UNS 2B						
公差 Tolerance	UN 2B						
	SA450-3		TL420VS-4	TL451VS-3	RTS420VS-4	RTS462VS-3	
DIN 标准 长型 DIN long	DIN 374						
	144		144	144	146	146	
DIN 标准 长型 DIN long	~ DIN 2184-1						
公差 Tolerance	UNF 2B	144		144	146	146	
公差 Tolerance	UNF(J) 3B	144	144	144			
公差 Tolerance	UNEF 2B						
公差 Tolerance	UNS 2B						
公差 Tolerance	UN 2B						

UNF

目录 - 机用挤压丝锥 ANSI B1.1

Directory - Machine thread formers ANSI B1.1

FS	FPS	FAS
VS	VS	VS
FS380VS-3	FPS381VS-3	FAS381VS-3
147	147	147
147	147	147



UNF,
UNEF, UNS, UN

www.dcswiss.com

UNF ANSI B1.1

≤ Ø 2.8 > Ø 2.8

PM **HSSE**



										N310-3	N320-3	N320-4	N320V-4
N310-3													
N320-3													
N320-4													
N320V-4	V												
Ø" d ₁ UNF	P TPI	d ₁ mm	l ₁ mm	l ₂ mm	l ₃ mm	d ₂ mm	a mm			ID	ID	ID	ID
0	80	1.52	40	7.0		2.5	2.1	2	1.20		101475		
1	72	1.85	40	8.0		2.5	2.1	2	1.50		* 101476		
2	64	2.18	45	9.0		2.8	2.1	2	1.80		101477		
4	48	2.84	56	12.0	18	3.5	2.7	3	2.35			128847	
5	44	3.17	56	12.0	18	3.5	2.7	3	2.60			142764	
6	40	3.50	56	13.0	20	4.0	3.0	3	2.90			101519	142765
8	36	4.16	63	14.0	21	4.5	3.4	3	3.50			101520	
10	32	4.82	70	15.0	25	6.0	4.9	3	4.05			101517	142766
12	28	5.48	80	17.0	30	6.0	4.9	3	4.60			101518	
1/4	28	6.35	80	17.0	30	7.0	5.5	3	5.50	101453		101516	142767
Ø" d ₁ UNF	P TPI	d ₁ mm	l ₁ mm	l ₂ mm	l ₃ mm	d ₂ mm	a mm			ID	ID	ID	ID
10	32	4.82	70	15.0	25	6.0	4.9	3	4.15			135506	
1/4	28	6.35	80	17.0	30	7.0	5.5	3	5.55			155323	











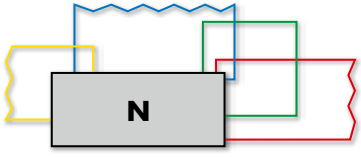







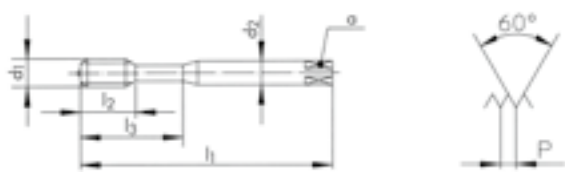

UNF ANSI B1.1

HSSE



										N410-3	N420-4	N420V-4	
N410-3													
N420-4													
N420V-4													
$\varnothing'' d_1$ UNF	P TPI	d_1 mm	l_1 mm	l_2 mm	d_2 mm	a mm				ID	ID	ID	
5/16	24	7.93	90	20.0	6.0	4.9	3	6.90		102004	102223	142774	
3/8	24	9.52	100	22.0	7.0	5.5	3	8.50		102003	102222	142775	
7/16	20	11.11	100	19.0	8.0	6.2	3	9.80		102006	102225	142776	
1/2	20	12.70	100	24.0	9.0	7.0	3	11.40		102000	102219	142777	
9/16	18	14.28	100	24.0	11.0	9.0	3	12.90			102227		
5/8	18	15.87	100	26.0	12.0	9.0	3	14.50		102005	102224	142778	
3/4	16	19.05	125	33.0	14.0	11.0	4	17.50		102002	102221	142779	
7/8	14	22.22	140	36.0	18.0	14.5	4	20.40		* 102007	102226		
1	12	25.40	160	39.0	18.0	14.5	4	23.30			102220	142780	
1 1/8	12	28.57	180	39.0	22.0	18.0	4	26.50			142773		
1 1/4	12	31.75	180	39.0	22.0	18.0	4	29.70			102218		
1 3/8	12	34.92	200	36.0	28.0	22.0	4	32.80			105137		
1 1/2	12	38.10	200	41.0	32.0	24.0	4	36.00		* 110986	105138		
$\varnothing'' d_1$ UNF	P TPI	d_1 mm	l_1 mm	l_2 mm	d_2 mm	a mm				ID			
5/16	24	7.93	90	20.0	6.0	4.9	3	7.00			155328		
3/8	24	9.52	100	22.0	7.0	5.5	3	8.60			155326		
7/16	20	11.11	100	19.0	8.0	6.2	3	10.00			155330		
1/2	20	12.70	100	24.0	9.0	7.0	3	11.55			155321		

UNF

										N360-3	N360V-3		
										 			
N360-3													
N360V-3	 												
													
													
													
$\varnothing'' d_1$ UNF	P TPI	d_1 mm	l_1 mm	l_2 mm	l_3 mm	d_2 mm	a mm			ID	ID		
6	40	3.50	56	6.5	20	4.0	3.0	3	2.90	101686			
8	36	4.16	63	7.5	21	4.5	3.4	3	3.50	* 101687	* 101733		
10	32	4.82	70	9.0	25	6.0	4.9	3	4.05	101682	101730		
12	28	5.48	80	11.0	30	6.0	4.9	3	4.60	101683			
1/4	28	6.35	80	11.0	30	7.0	5.5	3	5.50	101681	101729		
5/16	24	7.93	90	12.5	35	8.0	6.2	3	6.90	101685	101732		
3/8	24	9.52	100	14.0	39	10.0	8.0	3	8.50	101684	101731		
													
$\varnothing'' d_1$ UNF	P TPI	d_1 mm	l_1 mm	l_2 mm	l_3 mm	d_2 mm	a mm			ID			
10	32	4.82	70	9.0	25	6.0	4.9	3	4.15	155325			
1/4	28	6.35	80	11.0	30	7.0	5.5	3	5.55	155324			
5/16	24	7.93	90	12.5	35	8.0	6.2	3	7.00	155329			
3/8	24	9.52	100	14.0	39	10.0	8.0	3	8.60	155327			

UNF ANSI B1.1

HSSE



		N460-3		N460V-3						
N460-3										
N460V-3										
$\varnothing'' d_1$ UNF	P TPI	d_1 mm	l_1 mm	l_2 mm	d_2 mm	a mm			ID	ID
7/16	20	11.11	100	14.0	8.0	6.2	3	9.80	102434	142781
1/2	20	12.70	100	14.0	9.0	7.0	3	11.40	102430	102503
9/16	18	14.28	100	14.0	11.0	9.0	3	12.90	102436	143422
5/8	18	15.87	100	14.0	12.0	9.0	3	14.50	102433	143097
3/4	16	19.05	125	18.0	14.0	11.0	4	17.50	102432	102505
7/8	14	22.22	140	20.0	18.0	14.5	4	20.40	102435	144714
1	12	25.40	160	27.0	18.0	14.5	4	23.30	102431	102504
1 1/8	12	28.57	180	24.0	22.0	18.0	4	26.50	102429	144414
1 1/4	12	31.75	180	24.0	22.0	18.0	4	29.70	102428	151709
1 1/2	12	38.10	200	30.0	32.0	24.0	5	36.00	102427	148793
$\varnothing'' d_1$ UNF	P TPI	d_1 mm	l_1 mm	l_2 mm	d_2 mm	a mm			ID	ID
7/16	20	11.11	100	14.0	8.0	6.2	3	10.00	155331	
1/2	20	12.70	100	14.0	9.0	7.0	3	11.55	155322	

UNF

UNF ANSI B1.1

Z .20 Z .60

PM HSSE

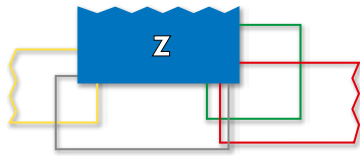
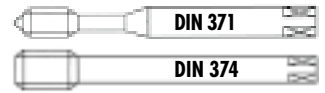

										Z320V-4	Z420V-4	Z360V-3	Z460V-3
Z320V-4													
Z420V-4													
Z360V-3													
Z460V-3													
$\varnothing^r d_1$ UNF	P TPI	d_1 mm	l_1 mm	l_2 mm	l_3 mm	d_2 mm	a mm			ID	ID		
10	32	4.82	70	15.0	25	6.0	4.9	3	4.05	142783			
1/4	28	6.35	80	17.0	30	7.0	5.5	3	5.50	142784			
5/16	24	7.93	90	20.0	35	8.0	6.2	3	6.90	142785			
3/8	24	9.52	100	22.0	39	10.0	8.0	3	8.50	142786			
7/16	20	11.11	100	19.0		8.0	6.2	3	9.80		142787		
1/2	20	12.70	100	24.0		9.0	7.0	3	11.40		142788		
$\varnothing^r d_1$ UNF	P TPI	d_1 mm	l_1 mm	l_2 mm	l_3 mm	d_2 mm	a mm			ID	ID		
10	32	4.82	70	9.0	25	6.0	4.9	3	4.05	104680			
1/4	28	6.35	80	11.0	30	7.0	5.5	3	5.50	104679			
5/16	24	7.93	90	12.5	35	8.0	6.2	3	6.90	104682			
3/8	24	9.52	100	14.0	39	10.0	8.0	3	8.50	104681			
7/16	20	11.11	100	14.0		8.0	6.2	3	9.80		104741		
1/2	20	12.70	100	14.0		9.0	7.0	3	11.40		104738		
5/8	18	15.87	100	14.0		12.0	9.0	3	14.50		104740		
3/4	16	19.05	125	18.0		14.0	11.0	4	17.50		104739		

UNF ANSI B1.1

PM

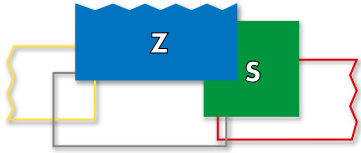
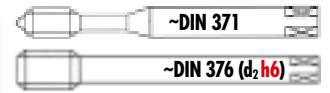

Z370VS-3

Z470VS-3

Z370VS-3



Z470VS-3

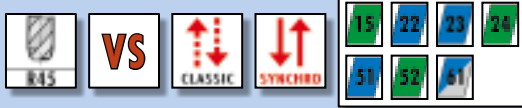

2BX

2BX

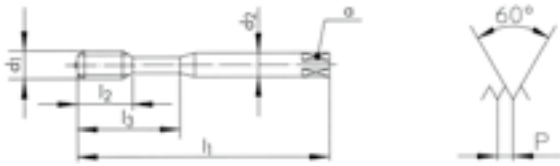

$\varnothing'' d_1$ UNF	P TPI	d_1 mm	l_1 mm	l_2 mm	l_3 mm	d_2, h_6 mm	α mm		
10	32	4.82	70	9.0	25	6.0	4.9	3	4.05
1/4	28	6.35	80	11.0	30	*6.0	*4.9	3	5.50
5/16	24	7.93	90	12.5	35	8.0	6.2	3	6.90
3/8	24	9.52	100	14.0	39	10.0	8.0	3	8.50
7/16	20	11.11	100	14.0		8.0	6.2	3	9.80
1/2	20	12.70	110	14.0		*10.0	*8.0	4	11.40

* DC 标准 / * DC Norm

3B
UNF(J)

$\varnothing'' d_1$ UNF	P TPI	d_1 mm	l_1 mm	l_2 mm	l_3 mm	d_2, h_6 mm	α mm		
10	32	4.82	70	9.0	25	6.0	4.9	3	4.15
1/4	28	6.35	80	11.0	30	*6.0	*4.9	3	5.55
5/16	24	7.93	90	12.5	35	8.0	6.2	3	7.00
3/8	24	9.52	100	14.0	39	10.0	8.0	3	8.60

* DC 标准 / * DC Norm

UNF

UNF ANSI B1.1

PM

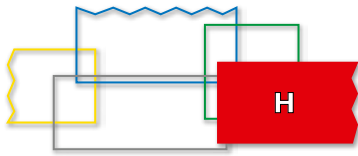
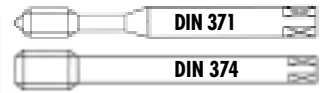

H320-4	H420-4		
--------	--------	--	--

H320-4



H420-4

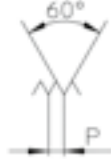
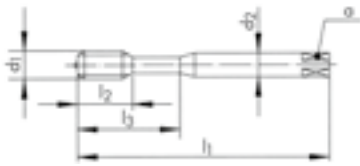

Ø" d ₁ UNF	P TPI	d ₁ mm	l ₁ mm	l ₂ mm	l ₃ mm	d ₂ mm	a mm		
10	32	4.82	70	15.0	25	6.0	4.9	3	4.05
1/4	28	6.35	80	17.0	30	7.0	5.5	3	5.50
5/16	24	7.93	90	20.0	35	8.0	6.2	3	6.90
3/8	24	9.52	100	22.0	39	10.0	8.0	3	8.50
1/2	20	12.70	100	24.0		9.0	7.0	4	11.40

ID	ID
101228	
101227	
105139	
101229	
	101291

UNF ANSI B1.1

PM

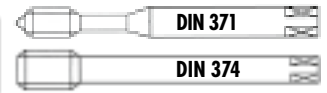

		H350-3	H450-3								
H350-3											
H450-3											
\varnothing d ₁ UNF	P TPI	d ₁ mm	l ₁ mm	l ₂ mm	l ₃ mm	d ₂ mm	α mm			ID	ID
10	32	4.82	70	9.0	25	6.0	4.9	3	4.05	101265	
1/4	28	6.35	80	11.0	30	7.0	5.5	3	5.50	101264	
5/16	24	7.93	90	12.5	35	8.0	6.2	3	6.90	101267	
3/8	24	9.52	100	14.0	39	10.0	8.0	3	8.50	101266	
7/16	20	11.11	100	14.0		8.0	6.2	3	9.80		101334
1/2	20	12.70	100	14.0		9.0	7.0	4	11.40		101331
5/8	18	15.87	100	14.0		12.0	9.0	4	14.50		101333
3/4	16	19.05	125	18.0		14.0	11.0	4	17.50		101332

UNF ANSI B1.1

PM

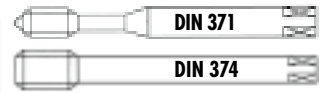

										S320VS-4	S420VS-4	S360VS-3	S460VS-3
S320VS-4		VS											
S420VS-4		VS											
S360VS-3		VS											
S460VS-3		VS											
$\varnothing'' d_1$ UNF	P TPI	d_1 mm	l_1 mm	l_2 mm	l_3 mm	d_2 mm	a mm			ID	ID		
10	32	4.82	70	15.0	25	6.0	4.9	3	4.15	111814			
1/4	28	6.35	80	17.0	30	7.0	5.5	3	5.55	111813			
5/16	24	7.93	90	20.0	35	8.0	6.2	3	7.00	111816			
3/8	24	9.52	100	22.0	39	10.0	8.0	3	8.60	111818			
7/16	20	11.11	100	22.0		8.0	6.2	3	10.00		111837		
$\varnothing'' d_1$ UNF	P TPI	d_1 mm	l_1 mm	l_2 mm	l_3 mm	d_2 mm	a mm			ID	ID		
10	32	4.82	70	9.0	25	6.0	4.9	3	4.05			* 111581	
1/4	28	6.35	80	11.0	30	7.0	5.5	3	5.50			* 111582	
5/16	24	7.93	90	12.5	35	8.0	6.2	3	6.90			* 111583	
7/16	20	11.11	100	14.0		8.0	6.2	3	9.80				* 111585
1/2	20	12.70	100	14.0		9.0	7.0	4	11.40				* 111586
$\varnothing'' d_1$ UNF	P TPI	d_1 mm	l_1 mm	l_2 mm	l_3 mm	d_2 mm	a mm			ID	ID		
10	32	4.82	70	9.0	25	6.0	4.9	3	4.15	111815			
1/4	28	6.35	80	11.0	30	7.0	5.5	3	5.55	111820			
5/16	24	7.93	90	12.5	35	8.0	6.2	3	7.00	111817			
3/8	24	9.52	100	14.0	39	10.0	8.0	3	8.60	111819			
7/16	20	11.11	100	14.0		8.0	6.2	3	10.00		111833		

aero

SA320-4 SA350-3 TL320VS-4 TL351VS-3

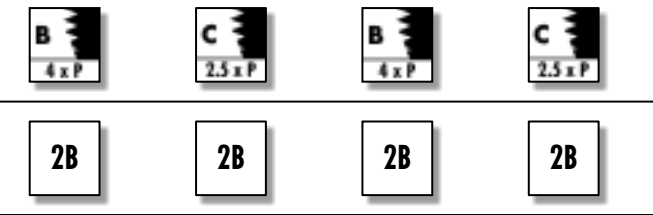

ID	ID	ID	ID
149133	149135	* 152046	152047
149230	149232	* 152065	152066
149277	149279	* 152071	152072
149339	149341	* 152082	152083



ID	ID	ID	ID
	149015		
146098	149138	* 148005	148004
146404	149235	* 148013	148012
146393	149282	* 148017	148016
147165	149344	* 148024	148023

SA320-4

SA350-3

TL320VS-4 **VS**

TL351VS-3 **VS**

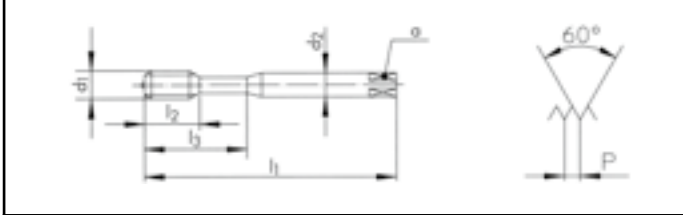

Ø" d ₁ UNF	P TPI	d ₁ mm	l ₁ mm	l ₂ mm	l ₃ mm	d ₂ mm	a mm		
10	32	4.82	70	15.0		6.0	4.9	3	4.05
1/4	28	6.35	80	15.0	23	7.0	5.5	3	5.50
5/16	24	7.93	90	18.0	29	8.0	6.2	3	6.90
3/8	24	9.52	100	20.0	33	10.0	8.0	3	8.50

Ø" d ₁ UNF	P TPI	d ₁ mm	l ₁ mm	l ₂ mm	l ₃ mm	d ₂ mm	a mm		
4	48	2.84	56	12.0		3.5	2.7	3	2.35
10	32	4.82	70	15.0		6.0	4.9	3	4.15
1/4	28	6.35	80	15.0	23	7.0	5.5	3	5.55
5/16	24	7.93	90	18.0	29	8.0	6.2	3	7.00
3/8	24	9.52	100	20.0	33	10.0	8.0	3	8.60

aero

SA420-4

SA450-3

TL420VS-4

TL451VS-3

SA420-4



SA450-3



TL420VS-4



TL451VS-3

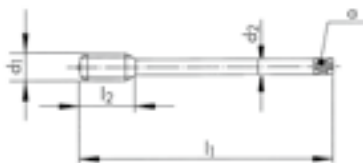

\varnothing d ₁ UNF	P TPI	d ₁ mm	l ₁ mm	l ₂ mm	d ₂ mm	a mm		
7/16	20	11.11	100	22.0	8.0	6.2	* 4	9.80
1/2	20	12.70	100	24.0	9.0	7.0	4	11.40
9/16	18	14.28	100	24.0	11.0	9.0	4	12.90
5/8	18	15.87	100	26.0	12.0	9.0	4	14.50

ID	ID	ID
152286	152290	* 152298
152287	152291	* 152299
* 152288		
* 152289		

\varnothing d ₁ UNF	P TPI	d ₁ mm	l ₁ mm	l ₂ mm	d ₂ mm	a mm		
7/16	20	11.11	100	22.0	8.0	6.2	* 4	10.00
1/2	20	12.70	100	24.0	9.0	7.0	4	11.55
9/16	18	14.28	100	24.0	11.0	9.0	4	13.05
5/8	18	15.87	100	26.0	12.0	9.0	4	14.60

ID	ID	ID	ID
147187	152302	* 152306	148031
147189	152303	* 152307	152310
146395			
147169			

* SA420-4 = 3
 * TL420VS-4 = 3

UNJF ASME B1.15 UNF ANSI B1.1

PM

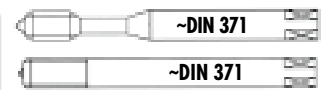

aero

SA320-4



SA390-3



SA320-4

SA390-3



NEW

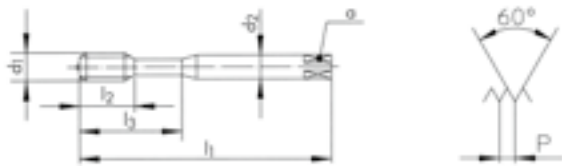

\varnothing " d_1 UNJF	P TPI	d_1 mm	l_1 mm	l_2 mm	l_3 mm	d_2 mm	a mm			ID
10	32	4.82	70	15.0		6.0	4.9	3	4.15	174976
1/4	28	6.35	80	15.0	23	7.0	5.5	3	5.55	175993
5/16	24	7.93	90	18.0	29	8.0	6.2	3	7.00	175995
3/8	24	9.52	100	20.0	33	10.0	8.0	3	8.60	175997

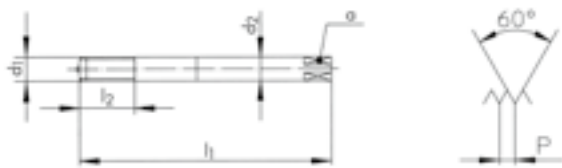

\varnothing " d_1 UNF	P TPI	d_1 mm	l_1 mm	l_2 mm	d_2 mm	a mm			ID
10	32	4.82	70	15.0	6.0	4.9	3	4.15	149687
1/4	28	6.35	80	20.0	7.0	5.5	3	5.55	149715
5/16	24	7.93	90	25.0	8.0	6.2	3	7.00	149728
3/8	24	9.52	100	30.0	10.0	8.0	3	8.60	149745

UNJF, UNF



只适用于刚性攻丝
Only for rigid tapping

PM

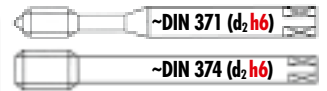

RTS Rigid Tapping Synchro

RTS320VS-4

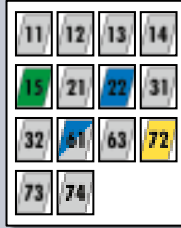

RTS420VS-4



RTS362VS-3

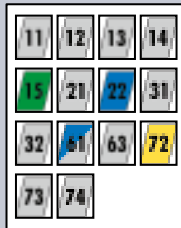

RTS462VS-3



RTS320VS-4

RTS420VS-4

RTS362VS-3

RTS462VS-3

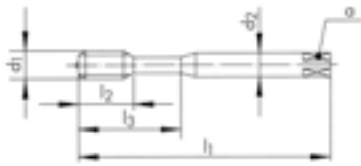

Ø" d ₁ UNF	P TPI	d ₁ mm	l ₁ mm	l ₂ mm	l ₃ mm	d ₂ h6 mm	α mm		
10	32	4.82	70	9.0	25	6.0	4.9	3	4.05
1/4	28	6.35	80	11.0	30	*6.0	*4.9	3	5.50
5/16	24	7.93	90	12.5	35	8.0	6.2	3	6.90
3/8	24	9.52	100	14.0	39	10.0	8.0	3	8.50
1/2	20	12.70	110	14.0		*10.0	*8.0	3	11.40

* DC 标准 / * DC Norm

ID

ID

ID

ID

157409

157413

157410

157414

157411

157415

157412

157416

157417

157418



应要求
on request

≥ Ø 6 mm

FS FPS FAS FORMING

FS380VS-5



VS

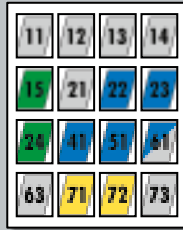

FPS381VS-3



VS

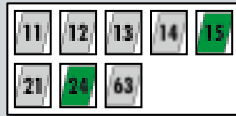

FAS381VS-3



VS

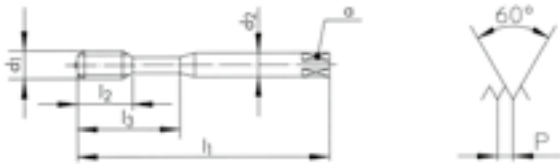

\varnothing d ₁ UNF	P TPI	d ₁ mm	l ₁ mm	l ₂ mm	l ₃ mm	d ₂ mm	α mm	$\frac{d_2}{P}$	Tol.
0	80	1.52	40	4.6		2.5	1.37		+ 0.02
10	32	4.82	70	15.0	25	6.0	4.9	4.45	+ 0.03
1/4	28	6.35	80	17.0	30	7.0	5.5	5.95	+ 0.05
5/16	24	7.93	90	20.0	35	8.0	6.2	7.45	+ 0.05

FS380VS-5



FPS381VS-3



FAS381VS-3



2BX

2BX

2BX

ID

ID

ID

161498

166718

166730

166719

166731

166720

166732

UNF ANSI B1.1

≤ Ø 2.8 > Ø 2.8

PM **HSS**









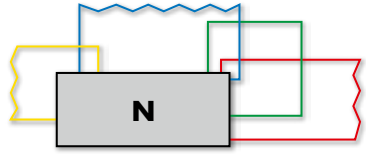

										N1110-1	N1110-3	N1110-S	
N1110-1													
N1110-3													
N1110-S													
Ø" d ₁ UNF	P TPI	d ₁ mm	l ₁ mm	l ₂ mm	l ₃ mm	d ₂ mm	a mm			ID	ID	ID	
0	80	1.52	40	7.0		2.50	2.10	3	1.20	102811	103010	111079	
1	72	1.85	40	8.0		2.50	2.10	3	1.50	102812	103011	111080	
4	48	2.84	48	11.0	18	3.15	2.50	3	2.35		* 103018		
8	36	4.16	53	13.0	21	4.50	3.55	3	3.50		* 103022		
10	32	4.82	58	16.0	25	5.00	4.00	3	4.05	102814	103013	111082	
12	28	5.48	62	17.0	26	5.60	4.50	3	4.60	* 102815	* 103014	* 111083	
1/4	28	6.35	66	19.0	30	6.30	5.00	3	5.50	102813	103012	111081	
5/16	24	7.93	72	22.0	35	8.00	6.30	3	6.90	102821	103020	111089	
3/8	24	9.52	80	24.0	39	10.00	8.00	3	8.50	102818	103017	111086	

UNF ANSI B1.1

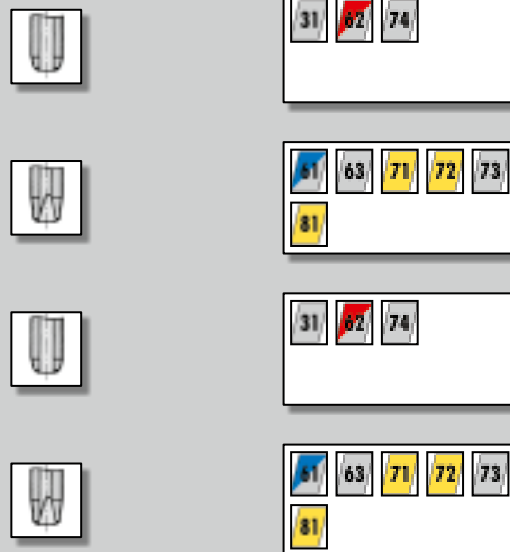

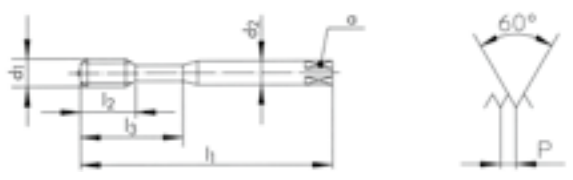
									N1210-1	N1210-3	N1210-S	
$\varnothing'' d_1$ UNF	P TPI	d_1 mm	l_1 mm	l_2 mm	d_2 mm	α mm			ID	ID	ID	
7/16	20	11.11	85	22.0	8.0	6.3	3	9.80	103411	103626	111255	
1/2	20	12.70	89	24.0	9.0	7.1	3	11.40	103407	103622	111251	
5/8	18	15.87	102	32.0	12.5	10.0	3	14.50	103410	103625	111254	
3/4	16	19.05	112	33.0	14.0	11.2	4	17.50	103409	103624	111253	
7/8	14	22.22	115	32.0	16.0	12.5	4	20.40	103412	103627	111256	
1	12	25.40	130	45.0	18.0	14.0	4	23.30	103408	103623	111252	

UNF

										N1110-3	N1120-4	N1210-3	N1220-4
													
													
													
													
Ø" d ₁ UNEF	P TPI	d ₁ mm	l ₁ mm	l ₂ mm	l ₃ mm	d ₂ mm	a mm			ID	ID	ID	ID
12	32	5.48	62	17.0	26	5.6	4.5	3	4.70	103007	103118		
1/4	32	6.35	66	19.0	30	6.3	5.0	3	5.60	103006	103117		
5/16	32	7.93	72	22.0	35	8.0	6.3	3	7.20	103009	103120		
3/8	32	9.52	80	24.0	39	10.0	8.0	3	8.75	103008	103119		
7/16	28	11.11	85	22.0		8.0	6.3	3	10.25			103615	103754
1/2	28	12.70	89	24.0		9.0	7.1	3	11.85			103609	103749
9/16	24	14.28	95	24.0		11.2	9.0	3	13.20			103617	103756
5/8	24	15.87	102	32.0		12.5	10.0	3	14.80			103614	103753
11/16	24	17.46	104	26.0		14.0	11.2	4	16.40			103611	
3/4	20	19.05	112	33.0		14.0	11.2	4	17.80			103613	* 103752
7/8	20	22.22	115	32.0		16.0	12.5	4	21.00			103616	* 103755
1	20	25.40	120	30.0		18.0	14.0	4	24.10			103610	* 103750

UNS, UN ANSI B1.1

HSSE























































										N410-3	N460-3	N460V-3	
N410-3													
N460-3													
N460V-3													
$\varnothing'' d_1$	P	d_1	l_1	l_2	d_2	a					ID	ID	ID
UNS	TPI	mm	mm	mm	mm	mm							
1/4	36	6.35	80	17.0	4.5	3.4	3	5.65		104899			
1/2	24	12.70	100	24.0	9.0	7.0	3	11.60		104900			
1	14	25.40	140	34.0	18.0	14.5	4	23.60		104898			
1	14	25.40	140	22.0	18.0	14.5	4	23.60			102437	142789	
$\varnothing'' d_1$	P	d_1	l_1	l_2	d_2	a					ID	ID	
UN	TPI	mm	mm	mm	mm	mm							
1 1/8	8	28.57	180	30.0	22.0	18.0	4	25.50			102415	142790	
1 1/4	8	31.75	180	30.0	22.0	18.0	4	28.70			102414	142520	
1 3/8	8	34.92	200	36.0	28.0	22.0	5	31.80			104896	142792	
1 1/2	8	38.10	200	40.0	32.0	24.0	5	35.00			102413	142793	
1 3/4	8	44.45	220	44.0	36.0	29.0	5	41.40				115198	
2	8	50.80	250	38.0	40.0	32.0	5	47.70				111622	

UNEF, UNS, UN

G 目录 - 机用丝锥 G (BSP) DIN ISO 228

Directory - Machine taps G (BSP) DIN ISO 228





















	N						
特点 Characteristics		 V	 TiN	 R40	 R40 V	 R40 V	 R40 TiN
							
洞型 Hole type							
							
	N410-3	N420-4 N420V-4	N420TN-4	N460-3	N460V-3	N462V-3	N460TN-3
DIN 标准 长型 DIN long DIN 5156	156	157	157	158	158	158	158
DIN 标准 短型 DIN short DIN 5157							
LH 左旋螺纹 LH Left hand thread DIN 5156	156						

















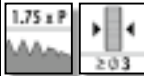

N			W		Z			
 	 	 	 	 	 	 	 	 
				 NEW				
								
N210-1	N210-3	N210-S	W460-5	W460DL-5	Z420V-4	Z420VS-4	Z460V-3	Z470VS-3
			159	159	160	160	160	161
163	163	163						

G (BSP),
Rp, Rc, W









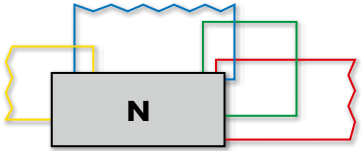

G

目录 - 机用丝锥和挤压丝锥 G (BSP) DIN ISO 228 Directory - Machine taps and thread formers G (BSP) DIN ISO 228



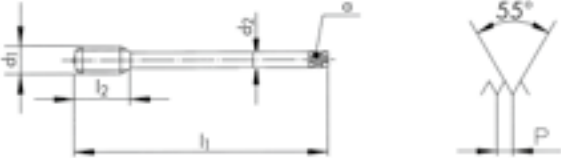







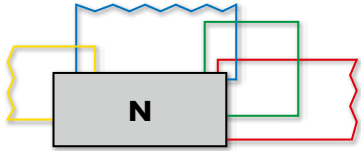



	H	GG	RTS	RTS	FPS	FAS	
特点 Characteristics		 NV	 VS	 E 1.5 x P VS	 VS	 VS	
							
洞型 Hole type							
							
	H450-3	GG450NV-3	RTS462VS-3	RTS462VS-5	FPS481VS-3	FAS481VS-3	
DIN 标准 长型 DIN long	DIN 5156	159	159				
DIN 标准 长型 DIN long	~DIN 376		161	161			
DIN 标准 长型 DIN long	~DIN 2189				162	162	

	N						
特点 Characteristics						 	
							
洞型 Hole type							
				N1110-3	N1120-4	N5120	
ISO 标准 短型 ISO short ISO 529				166	166		
W ISO 529				166/167	166		
SV ISO 529				167			
	N420-3	N410-3	D5800	N1210-3	N1220-4		
DIN 标准 长型 DIN long DIN 5156	164						
DIN 标准 长型 DIN long DC		164	165				
ISO 标准 短型 ISO short ISO 529				166	166		
Rp DIN 5156	164						
Rc DC		164	165				
W ISO 529				166	166		
SV ISO 529/DC				167		167	

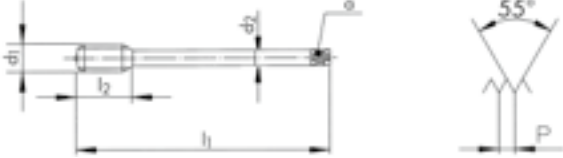
G (BSP),
Rp, Rc, W, SV

										N410-3	N410-3 LH		
													
N410-3  													
N410-3 LH  LH 													
													
\varnothing G d_1	P	d_1	l_1	l_2	d_2	α			ID	ID			
	TPI	mm	mm	mm	mm	mm							
1/8	28	9.72	90	22.0	7.0	5.5	3	8.75	101855				
1/4	19	13.15	100	20.0	11.0	9.0	3	11.60	101853	101854			
3/8	19	16.66	100	20.0	12.0	9.0	4	15.20	101861	101862			
1/2	14	20.95	125	22.0	16.0	12.0	4	18.90	101851	101852			
3/4	14	26.44	140	28.0	20.0	16.0	4	24.40	101859	* 101860			
1	11	33.24	160	32.0	25.0	20.0	4	30.70	101857	* 101858			
1 1/4	11	41.91	170	32.0	32.0	24.0	5	39.30	101850				
1 1/2	11	47.80	190	32.0	36.0	29.0	5	45.20	101849				

G DIN ISO 228 (BSP)

										N420-4	N420V-4	N420TN-4	
													
N420-4													
N420V-4	 V												
N420TN-4	 TiN												
													
$\varnothing'' d_1$ G	P TPI	d₁ mm	l₁ mm	l₂ mm	d₂ mm	a mm			ID	ID	ID		
1/16	28	7.72	90	18.0	6.0	4.9	3	6.75	102045				
1/8	28	9.72	90	22.0	7.0	5.5	3	8.75	102048	102258	102236		
1/4	19	13.15	100	20.0	11.0	9.0	3	11.60	102047	102257	102235		
3/8	19	16.66	100	20.0	12.0	9.0	3	15.20	102053	102261	102238		
1/2	14	20.95	125	22.0	16.0	12.0	4	18.90	102046	102256	102234		
5/8	14	22.91	125	25.0	18.0	14.5	4	20.90	102054	144722			
3/4	14	26.44	140	28.0	20.0	16.0	4	24.40	102052	102260	102237		
1	11	33.24	160	32.0	25.0	20.0	4	30.70	102049	102259			
1 1/4	11	41.91	170	32.0	32.0	24.0	5	39.30	102043				
1 1/2	11	47.80	190	32.0	36.0	29.0	5	45.20	102042				
2	11	59.61	220	36.0	45.0	35.0	5	57.00	102051				
2 1/2	11	75.18	280	36.0	50.0	39.0	6	72.60	102050				

G DIN ISO 228 (BSP)

HSSE



										N460-3	N460V-3	N460TN-3	N462V-3
N460-3													
N460V-3	V												
N460TN-3	TiN												
N462V-3	V												
$\frac{\text{Ø}''}{G}$ d_1	P TPI	d_1 mm	l_1 mm	l_2 mm	d_2 mm	α mm				ID	ID	ID	ID
1/16	28	7.72	90	12.5	6.0	4.9	3	6.75		102341			
1/8	28	9.72	90	14.0	7.0	5.5	3	8.75		102344	102457	102444	143687
1/4	19	13.15	100	14.0	11.0	9.0	3	11.60		102343	102456	102443	143600
3/8	19	16.66	100	14.0	12.0	9.0	4	15.20		102348	102460	102446	143431
1/2	14	20.95	125	20.0	16.0	12.0	4	18.90		102342	102455	102442	143921
5/8	14	22.91	125	20.0	18.0	14.5	4	20.90		102349	143711		
3/4	14	26.44	140	22.0	20.0	16.0	4	24.40		102347	102459	102445	143688
1	11	33.24	160	26.0	25.0	20.0	4	30.70		102345	102458		
1 1/4	11	41.91	170	30.0	32.0	24.0	5	39.30		102340	111608		
1 1/2	11	47.80	190	35.0	36.0	29.0	5	45.20		102339	111609		
2	11	59.61	220	41.0	45.0	35.0	6	57.00		102346	111503		

G DIN ISO 228 (BSP)

≤ Ø 25.4 > Ø 25.4

PM

H/GG

HSSE

H/GG

HSSE

W



DIN 5156

										W460-5	W460DL-5	H450-3	GG450NV-3	
W460-5 														
W460DL-5 														
H450-3 														
GG450NV-3 														
Ø" d ₁ G	P TPI	d ₁ mm	l ₁ mm	l ₂ mm	d ₂ mm	a mm				ID	ID	ID	ID	
1/8	28	9.72	90	14.0	7.0	5.5	3	8.75		119350	176728	101298		
1/4	19	13.15	100	14.0	11.0	9.0	*4	11.60		119300	176729	101297		
3/8	19	16.66	100	14.0	12.0	9.0	4	15.20		119682	176730	101301		
1/2	14	20.95	125	20.0	16.0	12.0	4	18.90		119199	176731	101296		
3/4	14	26.44	140	22.0	20.0	16.0	4	24.40				101300		
1	11	33.24	160	26.0	25.0	20.0	4	30.70				101299		
* W460-5 = 3														
Ø" d ₁ G	P TPI	d ₁ mm	l ₁ mm	l ₂ mm	d ₂ mm	a mm				ID				
1/8	28	9.72	90	22.0	7.0	5.5	4	8.75			102309			
1/4	19	13.15	100	20.0	11.0	9.0	4	11.60			102308			
3/8	19	16.66	100	20.0	12.0	9.0	4	15.20			102312			
1/2	14	20.95	125	22.0	16.0	12.0	4	18.90			102307			
3/4	14	26.44	140	28.0	20.0	16.0	4	24.40			102311			
1	11	33.24	160	32.0	25.0	20.0	4	30.70			102310			

G DIN ISO 228 (BSP)

< Ø 25.4 > Ø 25.4

PM
Z420

HSSE
Z420

HSSE
Z460

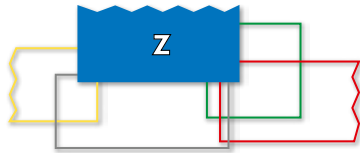

Z420V-4		V	21 22 23 41 42 51
Z420VS-4		VS	21 22 23 24 51 61
Z460V-3		V	22 23 51

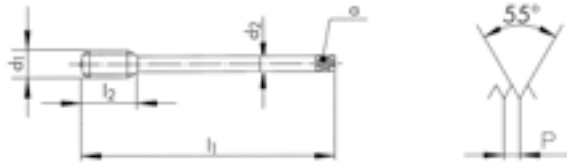

Ø" d ₁ G	P TPI	d ₁ mm	l ₁ mm	l ₂ mm	d ₂ mm	a mm			ID	ID
1/8	28	9.72	90	22.0	7.0	5.5	3	8.75	142794	142800
1/4	19	13.15	100	20.0	11.0	9.0	3	11.60	142795	119303
3/8	19	16.66	100	20.0	12.0	9.0	3	15.20	142796	142802
1/2	14	20.95	125	22.0	16.0	12.0	4	18.90	142797	142803
3/4	14	26.44	140	28.0	20.0	16.0	4	24.40	142798	
1	11	33.24	160	32.0	25.0	20.0	4	30.70	142799	

Ø" d ₁ G	P TPI	d ₁ mm	l ₁ mm	l ₂ mm	d ₂ mm	a mm			ID
1/8	28	9.72	90	14.0	7.0	5.5	3	8.75	104726
1/4	19	13.15	100	14.0	11.0	9.0	3	11.60	104725
3/8	19	16.66	100	14.0	12.0	9.0	4	15.20	104728
1/2	14	20.95	125	20.0	16.0	12.0	4	18.90	104724
3/4	14	26.44	140	22.0	20.0	16.0	4	24.40	104727
1	11	33.24	160	26.0	25.0	20.0	4	30.70	105142















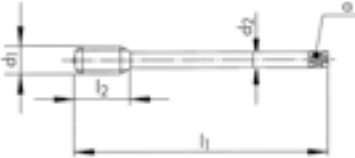

只适用于刚性攻丝
Only for rigid tapping

PM

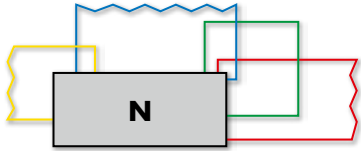
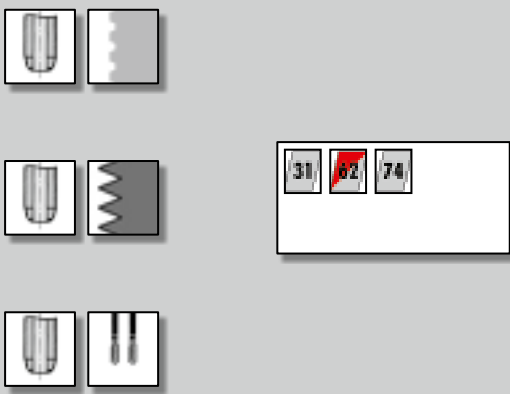

		Z470VS-3	RTS462VS-3	RTS462VS-5																																																																																																																														
Z470VS-3 																																																																																																																																		
RTS462VS-3 																																																																																																																																		
RTS462VS-5 																																																																																																																																		
<table border="1"> <thead> <tr> <th>$\varnothing'' d_1$</th> <th>P</th> <th>d_1</th> <th>l_1</th> <th>l_2</th> <th>$d_2 h6$</th> <th>α</th> <th></th> <th></th> <th>ID</th> </tr> <tr> <th>G</th> <th>TPI</th> <th>mm</th> <th>mm</th> <th>mm</th> <th>mm</th> <th>mm</th> <th></th> <th></th> <th></th> </tr> </thead> <tbody> <tr> <td>1/8</td> <td>28</td> <td>9.72</td> <td>100</td> <td>14.0</td> <td>*8.0</td> <td>*6.2</td> <td>3</td> <td>8.75</td> <td>165198</td> </tr> <tr> <td>1/4</td> <td>19</td> <td>13.15</td> <td>110</td> <td>14.0</td> <td>*12.0</td> <td>*9.0</td> <td>4</td> <td>11.60</td> <td>165199</td> </tr> <tr> <td>3/8</td> <td>19</td> <td>16.66</td> <td>110</td> <td>18.0</td> <td>12.0</td> <td>9.0</td> <td>4</td> <td>15.20</td> <td>165200</td> </tr> <tr> <td>1/2</td> <td>14</td> <td>20.95</td> <td>125</td> <td>20.0</td> <td>16.0</td> <td>12.0</td> <td>4</td> <td>18.90</td> <td>165201</td> </tr> </tbody> </table> <p>* DC 标准 / * DC Norm</p>		$\varnothing'' d_1$	P	d_1	l_1	l_2	$d_2 h6$	α			ID	G	TPI	mm	mm	mm	mm	mm				1/8	28	9.72	100	14.0	*8.0	*6.2	3	8.75	165198	1/4	19	13.15	110	14.0	*12.0	*9.0	4	11.60	165199	3/8	19	16.66	110	18.0	12.0	9.0	4	15.20	165200	1/2	14	20.95	125	20.0	16.0	12.0	4	18.90	165201	<table border="1"> <thead> <tr> <th>$\varnothing'' d_1$</th> <th>P</th> <th>d_1</th> <th>l_1</th> <th>l_2</th> <th>$d_2 h6$</th> <th>α</th> <th></th> <th></th> <th>ID</th> <th>ID</th> </tr> <tr> <th>G</th> <th>TPI</th> <th>mm</th> <th>mm</th> <th>mm</th> <th>mm</th> <th>mm</th> <th></th> <th></th> <th></th> <th></th> </tr> </thead> <tbody> <tr> <td>1/8</td> <td>28</td> <td>9.72</td> <td>100</td> <td>14.0</td> <td>*8.0</td> <td>*6.2</td> <td>3</td> <td>8.75</td> <td>151861</td> <td>170629</td> </tr> <tr> <td>1/4</td> <td>19</td> <td>13.15</td> <td>110</td> <td>14.0</td> <td>*12.0</td> <td>*9.0</td> <td>3</td> <td>11.60</td> <td>151868</td> <td>170631</td> </tr> <tr> <td>3/8</td> <td>19</td> <td>16.66</td> <td>110</td> <td>18.0</td> <td>12.0</td> <td>9.0</td> <td>4</td> <td>15.20</td> <td>151872</td> <td>170633</td> </tr> <tr> <td>1/2</td> <td>14</td> <td>20.95</td> <td>125</td> <td>20.0</td> <td>16.0</td> <td>12.0</td> <td>4</td> <td>18.90</td> <td>150685</td> <td>170635</td> </tr> </tbody> </table> <p>* DC 标准 / * DC Norm</p>			$\varnothing'' d_1$	P	d_1	l_1	l_2	$d_2 h6$	α			ID	ID	G	TPI	mm	mm	mm	mm	mm					1/8	28	9.72	100	14.0	*8.0	*6.2	3	8.75	151861	170629	1/4	19	13.15	110	14.0	*12.0	*9.0	3	11.60	151868	170631	3/8	19	16.66	110	18.0	12.0	9.0	4	15.20	151872	170633	1/2	14	20.95	125	20.0	16.0	12.0	4	18.90	150685	170635
$\varnothing'' d_1$	P	d_1	l_1	l_2	$d_2 h6$	α			ID																																																																																																																									
G	TPI	mm	mm	mm	mm	mm																																																																																																																												
1/8	28	9.72	100	14.0	*8.0	*6.2	3	8.75	165198																																																																																																																									
1/4	19	13.15	110	14.0	*12.0	*9.0	4	11.60	165199																																																																																																																									
3/8	19	16.66	110	18.0	12.0	9.0	4	15.20	165200																																																																																																																									
1/2	14	20.95	125	20.0	16.0	12.0	4	18.90	165201																																																																																																																									
$\varnothing'' d_1$	P	d_1	l_1	l_2	$d_2 h6$	α			ID	ID																																																																																																																								
G	TPI	mm	mm	mm	mm	mm																																																																																																																												
1/8	28	9.72	100	14.0	*8.0	*6.2	3	8.75	151861	170629																																																																																																																								
1/4	19	13.15	110	14.0	*12.0	*9.0	3	11.60	151868	170631																																																																																																																								
3/8	19	16.66	110	18.0	12.0	9.0	4	15.20	151872	170633																																																																																																																								
1/2	14	20.95	125	20.0	16.0	12.0	4	18.90	150685	170635																																																																																																																								
<p>应要求 on request</p>																																																																																																																																		

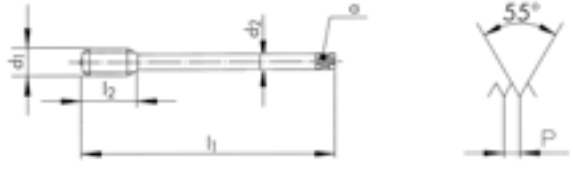
FPS FAS		FORMING		FPS481VS-3	FAS481VS-3												
FPS481VS-3		VS	<table border="1"> <tr> <td>11</td> <td>12</td> <td>13</td> <td>14</td> <td>15</td> </tr> <tr> <td>21</td> <td>24</td> <td>63</td> <td></td> <td></td> </tr> </table>	11	12	13	14	15	21	24	63						
11	12	13	14	15													
21	24	63															
FAS481VS-3		VS	<table border="1"> <tr> <td>12</td> <td>13</td> <td>14</td> <td>15</td> <td>21</td> <td>22</td> </tr> <tr> <td>23</td> <td>24</td> <td>41</td> <td>51</td> <td>61</td> <td>63</td> </tr> </table>	12	13	14	15	21	22	23	24	41	51	61	63		
12	13	14	15	21	22												
23	24	41	51	61	63												
 																	
$\varnothing d_1$ G	P TPI	d_1 mm	l_1 mm	l_2 mm	d_2 mm	α mm	\downarrow $\rightarrow \leftarrow$	Tol.	ID	ID							
1/8	28	9.72	90	22.0	7.0	5.5	9.25	+ 0.05	166721	166733							
1/4	19	13.15	100	20.0	11.0	9.0	12.50	+ 0.05	166722	166734							
3/8	19	16.66	100	20.0	12.0	9.0	16.00	+ 0.05	166723	166735							
1/2	14	20.95	125	22.0	16.0	12.0	20.00	+ 0.05	166724	166736							

										N210-1	N210-3	N210-S	
													
													
													
													
\varnothing d ₁ G	P TPI	d ₁ mm	l ₁ mm	l ₂ mm	d ₂ mm	a mm				ID	ID	ID	
1/16	28	7.72	63	18.0	6.0	4.9	3	6.75			101418		
1/8	28	9.72	63	22.0	7.0	5.5	3	8.75	101404	101421	119386		
1/4	19	13.15	70	20.0	11.0	9.0	3	11.60	101403	101420	119336		
3/8	19	16.66	70	20.0	12.0	9.0	4	15.20	101409	101427	110938		
1/2	14	20.95	80	22.0	16.0	12.0	4	18.90	101402	101419	119264		
5/8	14	22.91	80	25.0	18.0	14.5	4	20.90	101411	105140	110940		
3/4	14	26.44	90	28.0	20.0	16.0	4	24.40	101408	101426	110937		
7/8	14	30.20	90	28.0	22.0	18.0	4	28.20	* 101412	* 101429			
1	11	33.24	100	32.0	25.0	20.0	4	30.70	101405	101422	110933		
1 1/8	11	37.89	125	32.0	28.0	22.0	4	35.30		101415			
1 1/4	11	41.91	125	32.0	32.0	24.0	5	39.30	101400	101414	111425		
1 3/8	11	44.32	125	32.0	36.0	29.0	5	41.80		* 101417			
1 1/2	11	47.80	140	32.0	36.0	29.0	5	45.20	101399	101413	110934		
1 3/4	11	53.74	140	36.0	40.0	32.0	5	51.20		* 101416			
2	11	59.61	160	36.0	45.0	35.0	5	57.00	101407	101425	110935		
2 1/2	11	75.18	160	36.0	50.0	39.0	6	72.60		101423			
3	11	87.88	160	40.0	50.0	39.0	6	85.30		* 101428			

Rp, Rc DIN EN 10226

HSSE

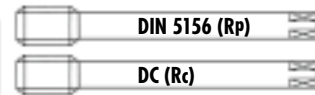

		N420-3			N410-3				
N420-3	 								
N410-3	 			 					
$\varnothing'' d_1$ Rp	P TPI	d_1 mm	l_1 mm	l_2 mm	d_2 mm	α mm			ID
1/8	28	9.72	90	22.0	7.0	5.5	3	8.60	104911
1/4	19	13.15	100	20.0	11.0	9.0	3	11.50	104912
3/8	19	16.66	100	20.0	12.0	9.0	3	15.00	104913
1/2	14	20.95	125	22.0	16.0	12.0	4	18.50	104914
3/4	14	26.44	140	28.0	20.0	16.0	4	24.00	104915
1	11	33.24	160	32.0	25.0	20.0	4	30.25	104916
$\varnothing'' d_1$ Rc	P TPI	d_1 mm	l_1 mm	l_2 mm	d_2 mm	α mm			ID
1/8	28	9.72	71	13.0	8.0	6.2	5		104917
1/4	19	13.15	80	20.0	11.0	9.0	5		104918
3/8	19	16.66	90	20.0	12.0	9.0	5		104919
1/2	14	20.95	100	26.0	16.0	12.0	5		104920
3/4	14	26.44	110	26.0	20.0	16.0	5		104921
1	11	33.24	125	32.0	25.0	20.0	5		104922

		Vc (m/min) $\varnothing d_1$			
Rc		1/16" - 1/4"	3/8" - 1/2"	3/4" - 1"	1.1/4" - 2"
		10	8	7	5
		18	15	13	10

					D5800
D5800					
\varnothing'' Rc	l_1 mm	l_2 mm	d_2 mm	α mm	
1/16	70	17.0	6.0	4.9	118701
1/8	70	17.0	8.0	6.2	110531
1/4	80	27.0	10.0	8.0	110530
3/8	85	27.0	12.0	9.0	110535
1/2	95	35.0	16.0	12.0	110529
3/4	105	35.0	20.0	16.0	110534
1	130	43.0	25.0	20.0	110532

锥管螺纹和 DIN EN 10226 的底孔直径 Core hole diameters for tapered pipe thread to DIN EN 10226

平衡孔
增加丝锥磨损，不推荐

Parallel hole
Increased tap wear, not recommended

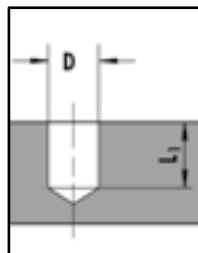

锥形孔
预钻至 $\varnothing D_2$
用锥度铰刀铰孔至 $\varnothing D_3$

Tapered hole 1:16
Pre-drill at $\varnothing D_2$
and taper-ream to $\varnothing D_3$

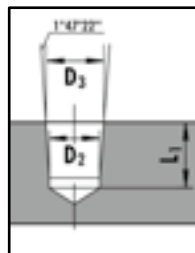

攻丝孔
攻丝至深度为
 $L_2 = \text{公称 } \varnothing$

Tapped hole
Engage tap to hole depth
 $L_2 = \text{nominal } \varnothing$

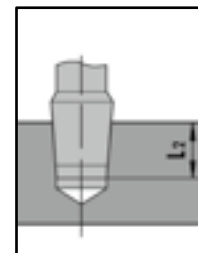

\varnothing'' Rc	L_1 min. mm	D_1 mm	D_2 mm	D_3 mm	L_2 mm
1/16	11.90	6.20	6.10	6.56	10.60
1/8	11.90	8.20	8.10	8.57	10.60
1/4	17.70	11.00	10.75	11.45	15.70
3/8	18.10	14.50	14.25	14.95	16.10
1/2	24.00	18.00	17.75	18.63	21.40
3/4	25.30	23.50	23.00	24.12	21.50
1	30.60	29.50	29.00	30.29	26.30

W BS 84 (BSW)

HSS

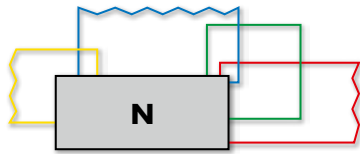
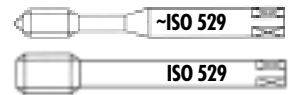

N1110-3			31 62 74
N1210-3			31 62 74
N1120-4			61 63 71 72 73 81
N1220-4			61 63 71 72 73 81

N1110-3	N1210-3	N1120-4	N1220-4
---------	---------	---------	---------



< 1.5 x D	< 1.5 x D		

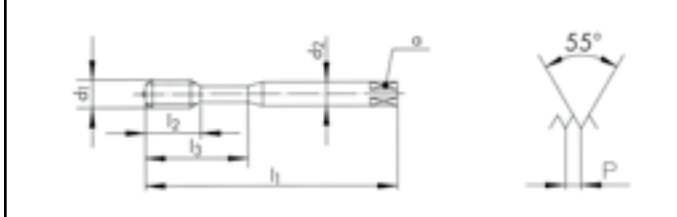

--	--	--	--















Ø" d ₁ W	P TPI	d ₁ mm	l ₁ mm	l ₂ mm	l ₃ mm	d ₂ mm	a mm		
1/8	40	3.17	48	11.0	18	3.15	2.50	3	2.50
5/32	32	3.96	53	13.0	21	4.00	3.15	3	3.10
3/16	24	4.76	58	16.0	25	5.00	4.00	3	3.60
1/4	20	6.35	66	19.0	30	6.30	5.00	3	4.90
5/16	18	7.93	72	22.0	35	8.00	6.30	3	6.40
3/8	16	9.52	80	24.0	39	10.00	8.00	3	7.70
7/16	14	11.11	85	22.0		8.00	6.30	3	9.10
1/2	12	12.70	89	24.0		9.00	7.10	3	10.30
9/16	12	14.28	95	24.0		11.20	9.00	3	11.90
5/8	11	15.87	102	32.0		12.50	10.00	3	13.30
3/4	10	19.05	112	33.0		14.00	11.20	3	16.20
1	8	25.40	130	45.0		18.00	14.00	4	21.90

ID	ID	ID	ID
103025		103126	
103031		103130	
103026		103127	
103024		103125	
103030		103129	
103028		103128	
	103642		103771
	103634		103767
	* 103644		
	103641		103770
	103640		103769
	* 103635		

								N1110-3		N1210-3		N5120			
N1110-3 															
N1210-3 														NEW	
N5120 														NEW	
														NEW	
\varnothing d ₁ W	P TPI/mm		l ₁ mm	l ₂ mm	l ₃ mm	d ₂ mm	a mm			ID					
5	36 TPI/1"	B6	58	16.0	25	5.0	4.0	3	4.20*	103029					
6.82	0.625	B8	66	19.0	30	7.1	5.6	3	6.15*	111143					
\varnothing d ₁ SV	P mm		l ₁ mm	l ₂ mm	l ₃ mm	d ₂ mm	a mm			ID		ID			
10	0.833	W10	80	24.0	39	10.0	8.0	3	8.80*	130429					
12	1.250	W12	89	24.0		9.0	7.1	3	10.50*			103591			
15	1.250	W15	90	23.0		11.2	9.0	3	13.50*			103592			
20	1.666	W20	112	37.0		14.0	11.2	4	17.80*			103593			
25	1.693	W25	120	30.0		18.0	14.0	4	22.70*			103594			
*Tol. $\begin{matrix} +0.1\text{ mm} \\ 0 \end{matrix}$															
\varnothing d ₁ W	P mm		d ₂ mm	l ₁ mm			ID								
6.82	0.625	B8	25.0	9.0	4	6.77	130215								

NPT, NPTF

目录 - 机用丝锥， NPT ANSI B1.20.1 和 NPTF B1.20.3
 Directory - Machine taps, NPT ANSI B1.20.1 and NPTF B1.20.3

		N						
特点 Characteristics		 	  					
								
洞型 Hole type								
								
	N410-3	N410V-3	N411V-3	D5800				
NPT DIN 标准 长型 NPT DIN long DC	170	170	170	171				
NPTF DIN 标准 长型 NPTF DIN long DC	170			171				

	N						
特点 Characteristics							
洞型 Hole type							
	N420-3	N410-1	N410-2	N410-3	N410-S	N410-8	
PG DIN 标准 长型 PG DIN long DIN 40433	172						
TR DIN 标准 长型 TR DIN long DC		173	173	173	173	172	
公差 Tolerance TR 7H				173	173	172	

NPT, NPTF
PG, TR

NPT, NPTF

ANSI B1.20.1, ANSI B1.20.3

HSSE



							N410-3	N410V-3	N411V-3	N410-3
N410-3										
N410V-3	V									
N411V-3	V									
N410-3										
\varnothing d ₁	P	l ₁	l ₂	d ₂	a		ID	ID	ID	ID
NPT, NPTF	TPI	mm	mm	mm	mm					
1/16	27	71	13.0	7.0	5.5	3	101961	102021	102031	101971
1/8	27	71	13.0	8.0	6.2	5				
1/4	18	80	20.0	11.0	9.0	5	101964	102024	102034	101974
3/8	18	90	20.0	12.0	9.0	5				
1/2	14	100	26.0	16.0	12.0	5	101963	102023	102033	101973
3/4	14	110	26.0	20.0	16.0	5	101968	102028	102038	101978
1	11.5	125	32.0	25.0	20.0	5	101962	102022	102032	101972
1 1/4	11.5	125	32.0	32.0	24.0	5	101967	102027	102037	101977
1 1/2	11.5	140	32.0	36.0	29.0	5	101965	102025	102035	101975
2	11.5	160	32.0	36.0	29.0	7	101960	102020		
							101959	102019		
							101966	102026		

		Vc (m/min) Ø d1					
NPT, NPTF 1/16" - 1/4"		3/8" - 1/2"	3/4" - 1"	1.1/4" - 2"			
				6	5	4	3
				5	4	3	2
				10	8	7	5
				18	15	13	10

NPT, NPTF

ANSI B1.20.1, ANSI B1.20.3

HSSE



					D5800			
D5800								
\varnothing'' NPT, NPTF	l_1 mm	l_2 mm	d_2 mm	a mm	ID			
1/16	70	17.0	6.0	4.9	118701			
1/8	70	17.0	8.0	6.2	110531			
1/4	80	27.0	10.0	8.0	110530			
3/8	85	27.0	12.0	9.0	110535			
1/2	95	35.0	16.0	12.0	110529			
3/4	105	35.0	20.0	16.0	110534			
1	130	43.0	25.0	20.0	110532			

NPT 和 NPTF 型螺纹的底孔直径 Core hole diameters for NPT and NPTF threads

<p>平衡孔 增加丝锥磨损，不推荐</p> <p>Parallel hole Increased tap wear, not recommended</p> <p>推荐锥度铰孔至 D_3 上限</p> <p>*Taper-ream at upper limit D_3 is recommended</p>	<p>锥形孔 预钻至 $\varnothing D_2$ 用锥度铰刀铰孔至 D_3</p> <p>Tapered hole 1:16 Pre-drill at $\varnothing D_2$ and taper-ream to $\varnothing D_3$</p>	<p>攻丝孔 攻丝至深度为 $L_2 =$ 公称 \varnothing</p> <p>Tapped hole Engage tap to hole depth $L_3 =$ nominal \varnothing</p>
---	---	--

\varnothing'' NPT, NPTF	D mm	L_1 mm	D_2 mm	NPT $D_3(+0.05)$ mm	NPTF $D_3(+0.05)$ mm	L_3 mm
1/16	6.15	12.00	6.00	6.39	6.41	10.20
1/8	8.50	12.00	8.30	8.74	8.76	10.30
1/4	11.00	17.50	10.80	11.36	11.40	15.10
3/8	14.50	17.50	14.20	14.80	14.84	15.30
1/2	17.90	23.00	17.50	18.32	18.33	20.00
3/4	23.20	23.00	22.80	23.67	23.68	20.50
1	29.00	28.00	28.60	29.69	29.72	24.60

NPT, NPTF

PG DIN 40430 TR ISO 2901-2904, DIN 103

HSSE

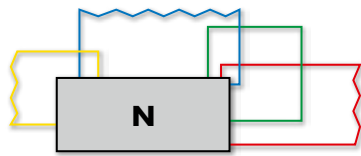
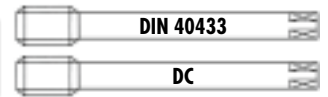

N420-3

N410-8

N420-3



N410-8

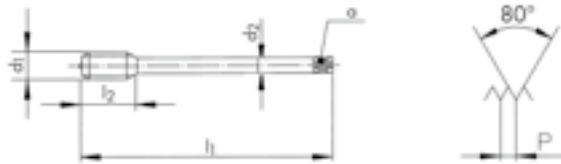



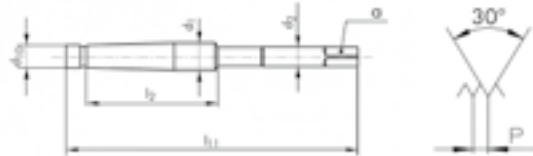





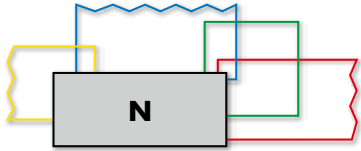

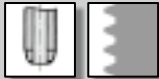



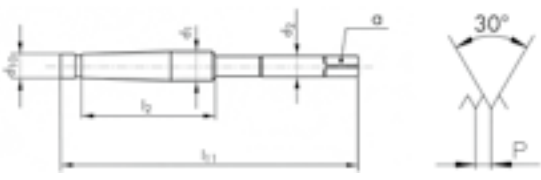

















Ø d ₁ PG	P TPI	d ₁ mm	l ₁ mm	l ₂ mm	d ₂ mm	a mm			ID
7	20	12.50	100	24.0	9.0	7.0	3	11.30	104901
9	18	15.20	100	26.0	12.0	9.0	3	13.90	104902
11	18	18.60	110	26.0	14.0	11.0	4	17.30	104903
13.5	18	20.40	125	28.0	16.0	12.0	4	19.10	104904
16	18	22.50	125	28.0	18.0	14.5	4	21.20	104905
21	16	28.30	150	36.0	22.0	18.0	4	26.80	104906
29	16	37.00	170	38.0	28.0	22.0	4	35.50	104907
36	16	47.00	190	38.0	36.0	29.0	5	45.50	104908























7H

Ø d ₁ TR	P mm	l ₁₁ mm	l ₂ mm	d ₁₀ mm	d ₂ mm	a mm			ID
10	2.00	100	45.0	8.20	7.0	5.5	3	8.20	102008
12	3.00	140	75.0	9.25	8.0	6.2	3	9.25	102009
14	3.00	150	75.0	11.25	10.0	8.0	3	11.25	102010
16	4.00	180	100.0	12.25	11.0	9.0	3	12.25	102011
18	4.00	180	100.0	14.25	12.0	9.0	3	14.25	102012
20	4.00	190	100.0	16.25	14.0	11.0	3	16.25	102013
22	5.00	220	110.0	17.25	16.0	12.0	4	17.25	111616
24	5.00	220	110.0	19.25	18.0	14.5	4	19.25	102015

									N410-1	N410-2	N410-3	N410-S
												
N410-1												
N410-2												
N410-3												
N410-S												
									<div style="border: 1px solid black; padding: 5px; display: inline-block;">7H</div>		<div style="border: 1px solid black; padding: 5px; display: inline-block;">7H</div>	
∅ d ₁ TR	P mm	l ₁₁ mm	l ₂ mm	d ₁₀ mm	d ₂ mm	a mm			ID	ID	ID	ID
10	2.00	85	30.0	8.20	7.0	5.5	3	8.20	* 101827	* 101838	* 101979	* 110972
12	3.00	115	45.0	9.25	8.0	6.2	3	9.25	* 101828	* 101839	* 101980	* 110973
16	4.00	165	65.0	12.25	11.0	9.0	3	12.25	* 101830	* 101841	* 101982	* 110975
20	4.00	175	65.0	16.25	14.0	11.0	3	16.25	* 101832	* 101843	* 101984	* 110977

	N				Z	S	
特点 Characteristics 		 V	 R40	 R40 V	 R45 VS	 VS	 R35 VS
							
洞型 Hole type							
	N320-4	N320V-4	N360-3	N360V-3	Z370VS-3	S320VS-4	S360VS-3
DIN 标准 长型 DIN long ~DIN 40435	176	176	177	177			
DIN 标准 长型 DIN long ~DIN 2184-1	180/183		180/183		181/184	184	184
螺丝 Thread EG M	176	176	177	177			
螺丝 Thread EG UNC	180		180		181		
螺丝 Thread EG UNF	183		183		184	184	184
	N420-4	N420V-4	N460-3	N460V-3			
DIN 标准 长型 DIN long ~DIN 40435	176	176	177	177			
DIN 标准 长型 DIN long ~DIN 2184-1	180/183		180/183				
螺丝 Thread EG M	176	176	177	177			
螺丝 Thread EG UNC	180		180				
螺丝 Thread EG UNF	183		183				

SA			TL	
				
				
				
				
SA320-4	SA350-3	SA390-3	TL320VS-4	TL351VS-3
178	178	179	178	178
182/185	182/185	184	182/185	182/185
178	178	179	178	178
182	182		182	182
185	185	184	185	185

THREADING
TECHNOLOGY



www.dcswiss.com

EG M, EG UN



≤ Ø 2.8 > Ø 2.8

PM

HSSE

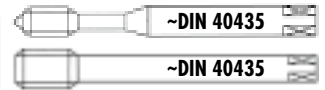

										N320-4	N320V-4	N420-4	N420V-4
N320-4													
N320V-4	V												
N420-4													
N420V-4	V												
Ø d ₁ EG M	P mm	d ₁ mm	l ₁ mm	l ₂ mm	l ₃ mm	d ₂ mm	a mm			ID	ID	ID	ID
2	0.40	2.520	50	10.0		2.8	2.1	3	2.10	101537	118788		
2.5	0.45	3.084	56	12.0	18	3.5	2.7	3	2.65	101538			
3	0.50	3.650	56	13.0	20	4.0	3.0	3	3.15	101539	142804		
4	0.70	4.910	70	15.0	25	6.0	4.9	3	4.20	101540	142805		
5	0.80	6.040	80	17.0	30	6.0	4.9	3	5.25	101541	142806		
6	1.00	7.300	80	17.0	30	7.0	5.5	3	6.30	101542	142807		
8	1.25	9.624	100	22.0	39	10.0	8.0	3	8.40	101543	142808		
10	1.50	11.948	100	24.0		9.0	7.0	3	10.40			102252	142809
12	1.75	14.274	110	28.0		11.0	9.0	3	12.50			102253	142810
14	2.00	16.598	110	30.0		12.0	9.0	3	14.60				* 142811
16	2.00	18.598	125	33.0		14.0	11.0	3	16.60			102255	142812



≤ Ø 2.8 > Ø 2.8

PM **HSSE**

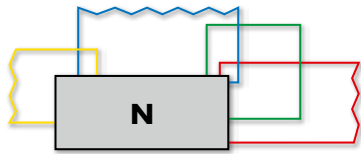
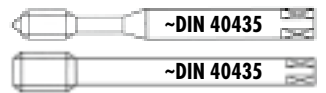

N360-3



N360V-3



N460-3



N460V-3



N360-3

N360V-3

N460-3

N460V-3



6H mod

6H mod

6H mod

6H mod

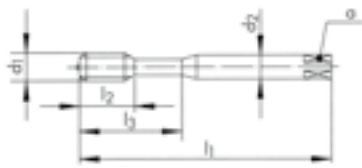

Ø d ₁ EG M	P mm	d ₁ mm	l ₁ mm	l ₂ mm	l ₃ mm	d ₂ mm	α mm		
2	0.40	2.520	50	9.0		2.8	2.1	2	2.10
2.5	0.45	3.084	56	5.5	18	3.5	2.7	3	2.65
3	0.50	3.650	56	6.5	20	4.0	3.0	3	3.15
4	0.70	4.910	70	9.0	25	6.0	4.9	3	4.20
5	0.80	6.040	80	11.0	30	6.0	4.9	3	5.25
6	1.00	7.300	80	11.0	30	7.0	5.5	3	6.30
8	1.25	9.624	100	14.0	39	10.0	8.0	3	8.40
10	1.50	11.948	100	14.0		9.0	7.0	3	10.40
12	1.75	14.274	110	14.0		11.0	9.0	3	12.50
14	2.00	16.598	110	18.0		12.0	9.0	3	14.60
16	2.00	18.598	125	21.0		14.0	11.0	3	16.60

ID

ID

ID

ID

101599

101600

101601

142813

101602

142814

101603

142815

101604

142816

101605

142817

102335

142818

102336

142819

102337

142820

102338

142821



aero

SA320-4

SA350-3

TL320VS-4 **VS**

TL351VS-3 **VS**

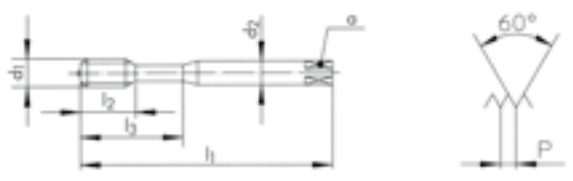

SA320-4	SA350-3	TL320VS-4	TL351VS-3
---------	---------	-----------	-----------

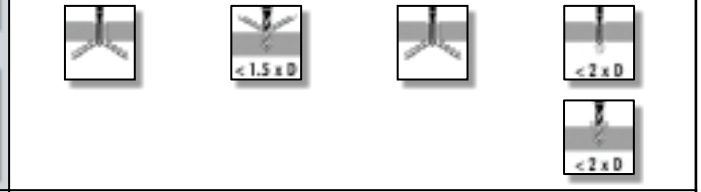

6H mod	6H mod	6H mod	6H mod

$\varnothing d_1$ EG M	P mm	d_2 mm	l_1 mm	l_2 mm	l_3 mm	d_2 mm	α mm		
3	0.50	3.650	56	13.0		4.0	3.0	3	3.15
4	0.70	4.910	70	15.0		6.0	4.9	3	4.20
5	0.80	6.040	80	15.0	23	6.0	4.9	3	5.25
6	1.00	7.300	80	15.0	23	7.0	5.5	3	6.30
8	1.25	9.624	100	20.0	33	10.0	8.0	3	8.40

ID	ID	ID	ID
147676	147682	* 152001	150478
147678	147684	* 152002	152003
147680	147686		150184
147688	147692	* 152004	152005
149354	149356	* 152088	152089



aero

SA390-3

SA390-3



$\varnothing d_1$ EG M	P mm	d_1 mm	l_1 mm	l_2 mm	d_2 mm	α mm		
3	0.50	3.650	56	13.0	4.0	3.0	3	3.15
4	0.70	4.910	70	15.0	6.0	4.9	3	4.20
5	0.80	6.040	80	20.0	6.0	4.9	3	5.25
6	1.00	7.300	80	20.0	7.0	5.5	3	6.30
8	1.25	9.624	100	30.0	10.0	8.0	3	8.40
10	1.50	11.948	110	35.0	12.0	9.0	3	10.40

ID

149669
149688
149710
149723
149748
149767



HSSE

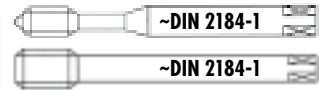

										N320-4	N420-4	N360-3	N460-3																																																																																										
N320-4																																																																																																							
N420-4																																																																																																							
N360-3																																																																																																							
N460-3																																																																																																							
										3B		3B																																																																																											
<table border="1"> <thead> <tr> <th>Ø" d₁ EG UNC</th> <th>P TPI</th> <th>d₁ mm</th> <th>l₁ mm</th> <th>l₂ mm</th> <th>l₃ mm</th> <th>d₂ mm</th> <th>a mm</th> <th></th> <th></th> </tr> </thead> <tbody> <tr><td>4</td><td>40</td><td>3.67</td><td>56</td><td>13.0</td><td>20</td><td>4.0</td><td>3.0</td><td>3</td><td>3.05</td></tr> <tr><td>6</td><td>32</td><td>4.53</td><td>70</td><td>15.0</td><td>25</td><td>6.0</td><td>4.9</td><td>3</td><td>3.75</td></tr> <tr><td>8</td><td>32</td><td>5.19</td><td>70</td><td>15.0</td><td>25</td><td>6.0</td><td>4.9</td><td>3</td><td>4.45</td></tr> <tr><td>10</td><td>24</td><td>6.20</td><td>80</td><td>17.0</td><td>30</td><td>7.0</td><td>5.5</td><td>3</td><td>5.10</td></tr> <tr><td>1/4</td><td>20</td><td>8.00</td><td>90</td><td>20.0</td><td>35</td><td>8.0</td><td>6.2</td><td>3</td><td>6.70</td></tr> <tr><td>5/16</td><td>18</td><td>9.77</td><td>100</td><td>22.0</td><td>39</td><td>10.0</td><td>8.0</td><td>3</td><td>8.40</td></tr> <tr><td>3/8</td><td>16</td><td>11.59</td><td>110</td><td>24.0</td><td></td><td>9.0</td><td>7.0</td><td>3</td><td>10.00</td></tr> <tr><td>1/2</td><td>13</td><td>15.23</td><td>110</td><td>30.0</td><td></td><td>12.0</td><td>9.0</td><td>3</td><td>13.30</td></tr> </tbody> </table>										Ø" d ₁ EG UNC	P TPI	d ₁ mm	l ₁ mm	l ₂ mm	l ₃ mm	d ₂ mm	a mm			4	40	3.67	56	13.0	20	4.0	3.0	3	3.05	6	32	4.53	70	15.0	25	6.0	4.9	3	3.75	8	32	5.19	70	15.0	25	6.0	4.9	3	4.45	10	24	6.20	80	17.0	30	7.0	5.5	3	5.10	1/4	20	8.00	90	20.0	35	8.0	6.2	3	6.70	5/16	18	9.77	100	22.0	39	10.0	8.0	3	8.40	3/8	16	11.59	110	24.0		9.0	7.0	3	10.00	1/2	13	15.23	110	30.0		12.0	9.0	3	13.30	ID		ID	
Ø" d ₁ EG UNC	P TPI	d ₁ mm	l ₁ mm	l ₂ mm	l ₃ mm	d ₂ mm	a mm																																																																																																
4	40	3.67	56	13.0	20	4.0	3.0	3	3.05																																																																																														
6	32	4.53	70	15.0	25	6.0	4.9	3	3.75																																																																																														
8	32	5.19	70	15.0	25	6.0	4.9	3	4.45																																																																																														
10	24	6.20	80	17.0	30	7.0	5.5	3	5.10																																																																																														
1/4	20	8.00	90	20.0	35	8.0	6.2	3	6.70																																																																																														
5/16	18	9.77	100	22.0	39	10.0	8.0	3	8.40																																																																																														
3/8	16	11.59	110	24.0		9.0	7.0	3	10.00																																																																																														
1/2	13	15.23	110	30.0		12.0	9.0	3	13.30																																																																																														
										110946		110948																																																																																											
										110949		* 110945																																																																																											
										110944		110947																																																																																											
												110033																																																																																											
												104935																																																																																											
<table border="1"> <thead> <tr> <th>Ø" d₁ EG UNC</th> <th>P TPI</th> <th>d₁ mm</th> <th>l₁ mm</th> <th>l₂ mm</th> <th>l₃ mm</th> <th>d₂ mm</th> <th>a mm</th> <th></th> <th></th> </tr> </thead> <tbody> <tr><td>4</td><td>40</td><td>3.67</td><td>56</td><td>6.5</td><td>20</td><td>4.0</td><td>3.0</td><td>3</td><td>3.05</td></tr> <tr><td>6</td><td>32</td><td>4.53</td><td>70</td><td>9.0</td><td>25</td><td>6.0</td><td>4.9</td><td>3</td><td>3.75</td></tr> <tr><td>8</td><td>32</td><td>5.19</td><td>70</td><td>9.0</td><td>25</td><td>6.0</td><td>4.9</td><td>3</td><td>4.45</td></tr> <tr><td>10</td><td>24</td><td>6.20</td><td>80</td><td>11.0</td><td>30</td><td>7.0</td><td>5.5</td><td>3</td><td>5.10</td></tr> <tr><td>1/4</td><td>20</td><td>8.00</td><td>90</td><td>12.5</td><td>35</td><td>8.0</td><td>6.2</td><td>3</td><td>6.70</td></tr> <tr><td>5/16</td><td>18</td><td>9.77</td><td>100</td><td>14.0</td><td>39</td><td>10.0</td><td>8.0</td><td>3</td><td>8.40</td></tr> <tr><td>3/8</td><td>16</td><td>11.58</td><td>110</td><td>14.0</td><td></td><td>9.0</td><td>7.0</td><td>3</td><td>10.00</td></tr> <tr><td>1/2</td><td>13</td><td>15.23</td><td>110</td><td>18.0</td><td></td><td>12.0</td><td>9.0</td><td>3</td><td>13.30</td></tr> </tbody> </table>										Ø" d ₁ EG UNC	P TPI	d ₁ mm	l ₁ mm	l ₂ mm	l ₃ mm	d ₂ mm	a mm			4	40	3.67	56	6.5	20	4.0	3.0	3	3.05	6	32	4.53	70	9.0	25	6.0	4.9	3	3.75	8	32	5.19	70	9.0	25	6.0	4.9	3	4.45	10	24	6.20	80	11.0	30	7.0	5.5	3	5.10	1/4	20	8.00	90	12.5	35	8.0	6.2	3	6.70	5/16	18	9.77	100	14.0	39	10.0	8.0	3	8.40	3/8	16	11.58	110	14.0		9.0	7.0	3	10.00	1/2	13	15.23	110	18.0		12.0	9.0	3	13.30	ID		ID	
Ø" d ₁ EG UNC	P TPI	d ₁ mm	l ₁ mm	l ₂ mm	l ₃ mm	d ₂ mm	a mm																																																																																																
4	40	3.67	56	6.5	20	4.0	3.0	3	3.05																																																																																														
6	32	4.53	70	9.0	25	6.0	4.9	3	3.75																																																																																														
8	32	5.19	70	9.0	25	6.0	4.9	3	4.45																																																																																														
10	24	6.20	80	11.0	30	7.0	5.5	3	5.10																																																																																														
1/4	20	8.00	90	12.5	35	8.0	6.2	3	6.70																																																																																														
5/16	18	9.77	100	14.0	39	10.0	8.0	3	8.40																																																																																														
3/8	16	11.58	110	14.0		9.0	7.0	3	10.00																																																																																														
1/2	13	15.23	110	18.0		12.0	9.0	3	13.30																																																																																														
												110018																																																																																											
												110019																																																																																											
												110956																																																																																											
												110954																																																																																											
												110024																																																																																											
												111759																																																																																											
												111715																																																																																											
												111558																																																																																											



PM

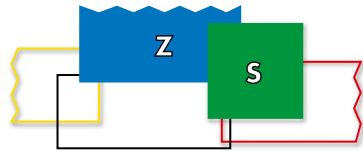

Z370VS-3

Z370VS-3

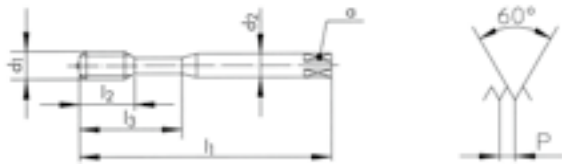
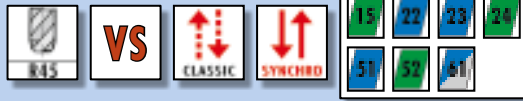

\varnothing " d ₁ EG UNC	P TPI	d ₁ mm	l ₁ mm	l ₂ mm	l ₃ mm	d ₂ h6 mm	a mm			ID
4	40	3.67	56	6.5	20	4.0 (h9)	3.0	3	3.05	165126
6	32	4.53	70	9.0	25	6.0	4.9	3	3.75	165127
8	32	5.19	70	9.0	25	6.0	4.9	3	4.45	165128

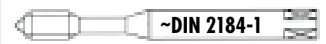

aero

										SA320-4	SA350-3	TL320VS-4	TL351VS-3
\varnothing d ₁ EG UNC	P TPI	d ₁ mm	l ₁ mm	l ₂ mm	l ₃ mm	d ₂ mm	a mm			ID	ID	ID	ID
4	40	3.67	56	13.0		4.0	3.0	3	3.05	149073	149075	* 152030	152031
6	32	4.53	70	15.0		6.0	4.9	3	3.75	149121	149123	* 152040	152041
8	32	5.19	70	15.0		6.0	4.9	3	4.45	149170	149172	* 152052	152053
1/4	20	8.00	90	18.0	29	8.0	6.2	3	6.70	149284	149286	* 152073	152074
5/16	18	9.77	100	20.0	33	10.0	8.0	3	8.40	* 149358	* 149360	* 152090	* 152091



HSSE

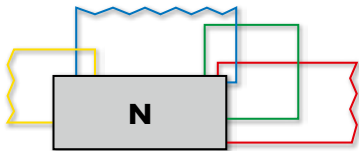
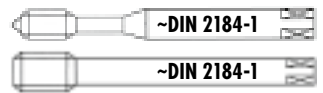

N320-4		
N420-4		
N360-3		
N460-3		

N320-4	N420-4	N360-3	N460-3
--------	--------	--------	--------



--	--	--	--

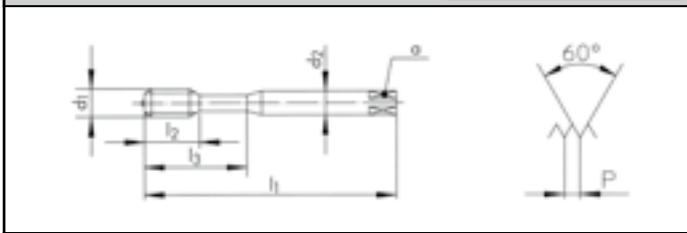

3B	3B	3B	3B

Ø" d ₁ EG UNF	P TPI	d ₁ mm	l ₁ mm	l ₂ mm	l ₃ mm	d ₂ mm	a mm		
6	40	4.33	63	14.0	21	4.5	3.4	3	3.70
8	36	5.08	70	15.0	25	6.0	4.9	3	4.40
10	32	5.85	80	17.0	30	6.0	4.9	3	5.10
1/4	28	7.52	90	20.0	35	8.0	6.2	3	6.65
5/16	24	9.31	90	20.0	35	9.0	7.0	3	8.20
3/8	24	10.89	100	19.0		8.0	6.2	3	9.80
1/2	20	14.35	100	24.0		11.0	9.0	3	13.10

ID	ID
118879	
118882	
104941	
110234	
118876	
	118873
	118865

Ø" d ₁ EG UNF	P TPI	d ₁ mm	l ₁ mm	l ₂ mm	l ₃ mm	d ₂ mm	a mm		
6	40	4.33	63	7.5	21	4.5	3.4	3	3.70
8	36	5.08	70	9.0	25	6.0	4.9	3	4.40
10	32	5.85	80	11.0	30	6.0	4.9	3	5.10
1/4	28	7.52	90	12.5	35	8.0	6.2	3	6.65
5/16	24	9.31	90	12.5	35	9.0	7.0	3	8.20
3/8	24	10.89	100	19.0		8.0	6.2	3	9.80
1/2	20	14.35	100	14.0		11.0	9.0	3	13.10

ID	ID
	110959
	110960
	104946
	110020
	111619
	110027
	104951

EG UNC
EG UNF

EG UNF NASM33537



PM

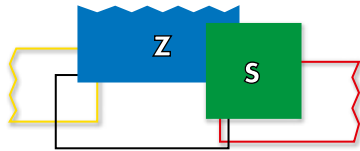
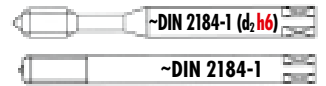

Z370VS-3

S320VS-4

S360VS-3

Z370VS-3

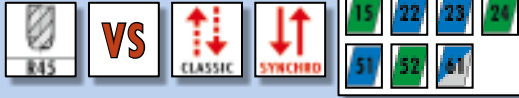

S320VS-4



S360VS-3



SA390-3



3B

3B

3B

3B

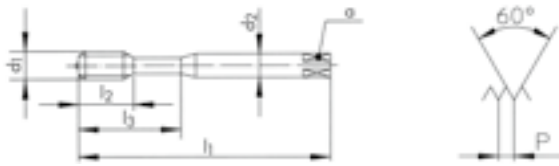

\varnothing " d ₁ EG UNF	P TPI	d ₁ mm	l ₁ mm	l ₂ mm	l ₃ mm	d ₂ h6 mm	a mm		
10	32	5.85	80	11.0	30	6.0	4.9	3	5.10
1/4	28	7.52	90	12.5	35	8.0	6.2	3	6.65
5/16	24	9.31	90	12.5	35	*8.0	*6.2	3	8.20

* DC 标准 / * DC Norm

\varnothing " d ₁ EG UNF	P TPI	d ₁ mm	l ₁ mm	l ₂ mm	l ₃ mm	d ₂ mm	a mm		
10	32	5.85	80	17.0	30	6.0	4.9	3	5.10
1/4	28	7.52	90	20.0	35	8.0	6.2	3	6.65
5/16	24	9.31	90	20.0	35	9.0	7.0	3	8.20

\varnothing " d ₁ EG UNF	P TPI	d ₁ mm	l ₁ mm	l ₂ mm	l ₃ mm	d ₂ mm	a mm		
10	32	5.85	80	11.0	30	6.0	4.9	3	5.10
1/4	28	7.52	90	12.5	35	8.0	6.2	3	6.65
5/16	24	9.31	90	12.5	35	9.0	7.0	3	8.20

\varnothing " d ₁ EG UNF	P TPI	d ₁ mm	l ₁ mm	l ₂ mm	d ₂ mm	a mm		
10	32	5.85	80	20.0	6.0	4.9	3	5.10
1/4	28	7.52	90	25.0	8.0	6.2	3	6.65

ID

165129
165130
165131

ID

111821
111822
111823

ID

111811
111812
111824

ID

149702
149724



aero

SA320-4

SA350-3

TL320VS-4

TL351VS-3



SA320-4



SA350-3



TL320VS-4



VS



TL351VS-3



VS



Ø" d ₁ EG UNF	P TPI	d ₁ mm	l ₁ mm	l ₂ mm	l ₃ mm	d ₂ mm	a mm		
10	32	5.85	80	15.0	23	6.0	4.9	3	5.10
1/4	28	7.52	90	18.0	29	8.0	6.2	3	6.65
5/16	24	9.31	90	20.0	31	9.0	7.0	3	8.20

ID

ID

ID

ID

149190

149192

* 148009

148008

146099

149268

* 148015

148014

149336

149338

148021

王冠形丝锥

CROWN TAPS

通用信息

带防冷焊“V”表面处理的 DC 王冠形丝锥是一款高性能刀具，能够完成高质量的螺纹表面处理。

使用范围

DC 王冠形丝锥前端的凹形空间能容纳切屑，这款丝锥适用于盲孔和通孔。刀具可以加工抗拉度高达 850 N/mm² 和延伸率高达 30 % 的材料。

使用方法

王冠形丝锥适合加工任何深度的通孔。但为了最适当地加工盲孔，底孔深度必须适当作出调整，攻丝时请遵守以下使用说明：

- 不停攻丝直到攻丝头的过载离合器分离
- 取出丝锥，清理切屑
- 加工至洞底

通用提示

为了保证 DC 王冠形丝锥的加工效率和螺纹的质量，请遵守以下规则：

- 中心偏差不要超出 0.1 毫米
- 固定丝锥时保证完美同心度，使用适合的攻丝头
- 使用正确的切削速度攻丝
- 选择适合加工材料的冷冻剂
- 使用带有轴向补偿和过载离合器的攻丝头
- 把过载离合器设定在扭矩上方

在第一次攻丝时，请把离合器松开，然后逐渐拉紧直到丝锥能被驱动。

切屑累积

凹槽的容屑量如下：

螺纹直径	Ø 20 - 29 mm	≥ Ø 30 mm
M	-	1.4 x D
MF	1.2 x D	1.4 x D
UN-8	-	1.4 x D

General information

The DC crown tap with “V” surface treatment to prevent cold welding is a tool of high performance, which offers a very high quality surface finish of the tapped threads.

Application rang

Thanks to the front recess providing space for the chip collection, the DC crown tap is suitable for both, through and blind hole tapping. The crown tap can be used for materials with a tensile strength up to 850 N/mm² and an elongation of maximum 30 %.

Utilization

The crown tap can be used for through holes of any depth. However, for an optimal blind hole threading, the core hole depth must be adapted accordingly and the following application instructions must be followed:

- Tap until tapping head clutch slips
- Retract tap and clear chips
- Tap to the full depth.

General hints

The efficient operation of DC crown taps, as well as the quality of the cut threads, depend on observation of the following rules:

- Do not exceed the maximum permissible centering error of 0.1 mm
- The tap must run concentrically, use a suitable tapping head
- Tap at the correct cutting speed
- Select a coolant to suit the material being tapped
- Use a tapping head with axial compensation and safety clutch
- Set the safety clutch so that it will slip at just above the tapping torque.

When tapping the first hole, slacken the clutch until it slips, then gradually tighten it until the tap is driven.

Chip accumulation

The chip accumulation capacity of the recess is the following :

Thread diameter	Ø 20 - 29 mm	≥ Ø 30 mm
M	-	1.4 x D
MF	1.2 x D	1.4 x D
UN-8	-	1.4 x D
G	1.2 x D	1.4 x D

切削速度和主轴速度 (参考数据) - Cutting and spindle speeds (guide values)

M				MF				MF				UN-8			
M	P	V _c (m/min)	n (U/min)	MF	P	V _c (m/min)	n (U/min)	MF	P	V _c (m/min)	n (U/min)	UN-8	P TPI	V _c (m/min)	n (U/min)
30	3.5	7.9	84	22	1.5	8.0	116	45	1.5	6.9	49	1 1/4"	8.0	7.8	77
33	3.5	7.7	74	24	1.5	8.0	106	45	2.0	6.9	49	1 3/8"	8.0	7.6	69
36	4.0	7.5	66	26	1.5	7.9	97	48	1.5	6.6	44	1 1/2"	8.0	7.3	62
39	4.0	7.3	60	28	1.5	7.9	90	48	2.0	6.6	44	1 5/8"	8.0	7.1	55
42	4.5	7.1	54	30	1.5	7.9	84	48	3.0	6.6	44	1 3/4"	8.0	6.9	49
45	4.5	6.9	49	30	2.0	7.9	84	48	4.0	6.6	44	1 7/8"	8.0	6.7	45
48	5.0	6.6	44	32	1.5	7.8	77	50	1.5	6.5	41	2"	8.0	6.4	40
52	5.0	6.4	39	32	2.0	7.8	77	52	1.5	6.4	39				
56	5.5	6.1	35	33	1.5	7.7	74	52	3.0	6.4	39				
60	5.5	5.8	31	33	2.0	7.7	74	55	1.5	6.2	36				
64	6.0	5.5	28	34	1.5	7.6	71	56	4.0	6.1	35				
68	6.0	5.2	25	35	1.5	7.6	69	60	2.0	5.8	31				
				36	1.5	7.5	66	64	4.0	5.5	28				
				36	2.0	7.5	66	68	4.0	5.2	25				
				36	3.0	7.5	66	72	6.0	5.0	22				
				38	1.5	7.3	62	76	6.0	4.7	20				
				40	1.5	7.2	57	80	2.0	4.4	18				
				40	2.0	7.2	57	80	4.0	4.4	18				
				42	1.5	7.1	54	80	6.0	4.4	18				
				42	2.0	7.1	54	90	6.0	3.7	13				
				42	3.0	7.1	54	100	6.0	3.0	10				
				42	4.0	7.1	54	110	6.0	2.5	7				

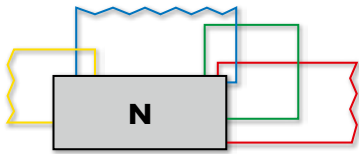

N470V-4

N470V-4

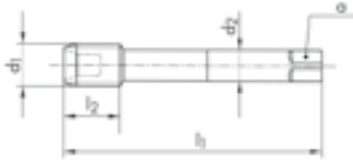

$\varnothing d_1$ M	P mm	l_1 mm	l_2 mm	d_2 mm	a mm		
30	3.50	180	39.0	22.0	18.0	5	26.50
33	3.50	180	39.0	22.0	18.0	5	29.50
36	4.00	200	43.0	25.0	20.0	5	32.00
39	4.00	200	43.0	25.0	20.0	5	35.00
42	4.50	220	47.0	28.0	22.0	5	37.50
45	4.50	220	47.0	28.0	22.0	5	40.50
48	5.00	240	52.0	32.0	24.0	5	43.00
52	5.00	240	52.0	32.0	24.0	5	47.00
56	5.50	260	58.0	36.0	29.0	6	50.50
60	5.50	260	58.0	36.0	29.0	6	54.50
64	6.00	290	64.0	40.0	32.0	6	58.00
68	6.00	290	64.0	40.0	32.0	6	62.00

ID

102575

* 102576

102577

102578

102579

102580

102581

102582

102583

102584

102585

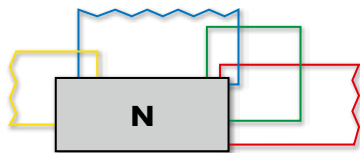

* 102586

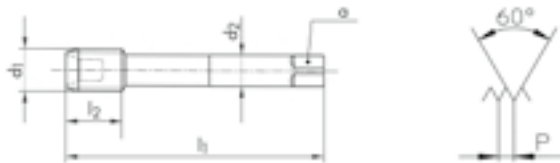

N470V-3

N470V-3



$\varnothing d_1$ MF	P mm	l_1 mm	l_2 mm	d_2 mm	a mm			ID
^Δ 22	1.50	125	28.0	18.0	14.5	4	20.50	* 102526
^Δ 26	1.50	140	30.0	18.0	14.5	4	24.50	* 102529
^Δ 28	1.50	140	30.0	20.0	16.0	4	26.50	* 102530
30	1.50	160	32.0	22.0	18.0	5	28.50	* 102531
32	1.50	160	32.0	22.0	18.0	5	30.50	* 102533
34	1.50	160	26.0	22.0	18.0	5	32.50	* 102537
35	1.50	175	28.0	25.0	20.0	5	33.50	* 102538
36	2.00	175	35.0	25.0	20.0	5	34.00	102540
36	3.00	200	43.0	25.0	20.0	5	33.00	102541
38	1.50	175	28.0	25.0	20.0	5	36.50	* 102542
40	1.50	190	31.0	28.0	22.0	5	38.50	* 102543
40	2.00	190	38.0	28.0	22.0	5	38.00	* 102544
42	2.00	190	38.0	28.0	22.0	5	40.00	102546
42	3.00	220	47.0	28.0	22.0	5	39.00	102547
48	1.50	205	34.0	32.0	24.0	5	46.50	* 102551
48	3.00	205	41.0	32.0	24.0	5	45.00	102553
52	3.00	205	41.0	32.0	24.0	5	49.00	102557
56	4.00	260	58.0	36.0	29.0	6	52.00	102559
64	4.00	290	64.0	40.0	32.0	6	60.00	102561
80	4.00	270	56.0	45.0	35.0	7	76.00	* 102564



										N470V-3			
N470V-3													
$\varnothing^{\prime\prime} d_1$	P	d_1	l_1	l_2	d_2	a				ID			
UN	TPI	mm	mm	mm	mm	mm							
1 1/4	8	31.75	180	39.0	22.0	18.0	5	28.70		102566			
1 3/8	8	34.92	180	39.0	22.0	18.0	5	31.80		102568			
1 1/2	8	38.10	200	43.0	25.0	20.0	5	35.00		102565			
1 5/8	8	41.27	220	47.0	28.0	22.0	5	38.20		102569			
1 3/4	8	44.45	220	47.0	28.0	22.0	5	41.40		102567			
1 7/8	8	47.62	240	52.0	32.0	24.0	5	44.50		102570			
2	8	50.80	205	41.0	32.0	24.0	5	47.70		102572			
2 1/4	8	57.15	220	45.0	36.0	29.0	6	54.10		102571			
2 1/2	8	63.50	220	45.0	36.0	29.0	6	60.40		111879			
$\varnothing^{\prime\prime} d_1$	P	d_1	l_1	l_2	d_2	a				ID			
G	TPI	mm	mm	mm	mm	mm							
[^] 1/2	14	20.95	140	32.0	16.0	12.0	4	18.90		* 102521			
[^] 3/4	14	26.44	150	34.0	20.0	16.0	4	24.40		102525			
1	11	33.24	160	32.0	22.0	18.0	5	30.70		102522			
1 1/4	11	41.91	190	38.0	28.0	22.0	5	39.30		102519			
1 1/2	11	47.80	205	41.0	32.0	24.0	5	45.20		102518			
1 3/4	11	53.74	205	41.0	32.0	24.0	5	51.20		* 102520			
2	11	59.61	220	45.0	36.0	29.0	6	57.00		102524			



钻攻一体丝锥

通用信息

使用DC钻攻一体丝锥，不需要更换刀具就能完成钻削和螺纹加工。这是最适合用于 CNC 数控机床，钻削头，转塔式六角车床和攻丝机床的刀具。

使用范围

推荐使用钻攻一体刀具加工抗拉强度不超出 750 N/mm² 的材料，例如钢材，铸铁，铝，黄铜。

通用提示

- 在丝锥开始切削前，底孔必须要被完全穿透
- 加工短屑材料时，螺纹深度不要超过 1.8 x D (N5952 型不超过 2 x D)
- 加工长屑材料时，螺纹深度不要超过 1.2 x D
- 按照攻丝的润滑方式润滑

切削速度

使用钻削头和 CNC 数控机床时，请选择适合的钻削速度和螺纹切削速度（请参考第七页的应用图表）。

如果钻削和攻丝速度相同，请参考下列数据。

切削速度和主轴速度 (参考数据)

材料组	Vc (m/min)	按螺纹直径排列速度										
		M3	M4	M5	M6	M8	M10	M12	M14	M16	M18	M20
强度 <500 N/mm ² 钢材	20	2120	1600	1270	1060	800	640	530	460	400	360	320
强度 >500 N/mm ² 钢材	15	1600	1200	950	800	600	480	400	340	300	270	240
铸铁，软	20	2120	1600	1270	1060	800	640	530	460	400	360	320
铸铁，硬	15	1600	1200	950	800	600	480	400	340	300	270	240
黄铜	25	2650	2000	1600	1330	950	800	660	570	500	450	400
铝	25	2650	2000	1600	1330	950	800	660	570	500	450	400

编程说明

镗孔：

同时镗孔和定心

主轴进给和旋转百分之一百同步时的编程步骤 (最佳状况)：

- 1) 把丝锥安装在起始位并加速
- 2) 钻削
 - 设定速度
 - 设定进给
 - 避免长切屑
 - 清除切屑
- 3) 攻丝部分回到起始位
- 4) 攻丝
 - 设定速度
 - 进给 = 100 % 螺距
 - 设定螺纹深度
 - 切削前清理所有切屑
- 5) 丝锥回到起始位

主轴进给和旋转不完全同步时的编程步骤：

注意：把丝锥安装在带锁定压缩弹簧和轴向补偿的夹柄上

- 1) 把丝锥安装在起始位并加速
- 2) 钻削
 - 设定速度
 - 设定进给
 - 避免长切屑
 - 清除切屑
- 3) 攻丝部分回到起始位
- 4) 攻丝
 - 设定速度
 - 进给 = 90 - 95 % 螺距
 - 设定螺纹深度
 - 切削前清理所有切屑
- 5) 丝锥回到起始位

COMBINATION DRILL/TAPS

General information

DC combination drill/taps - two tools in one, which allows the drilling and the threading of a workpiece without changing the tool.

It is the optimal solution for CNC-machines, drilling heads, turret lathes and tapping machines.

Application rang

DC combination drill/taps are recommended for use in materials with a tensile strenght up to 750 N/mm², such as certain steels, cast iron, aluminium, brass.

General hints

- The core hole must be completely drilled through before the tap starts cutting.
- In short chipping materials, the depth of thread should not exceed 1.8 x D (type N5952 up to 2 x D).
- In long chipping materials, the depth of thread should not exceed 1.2 x D.
- Lubricate as for tapping.

Cutting speeds

On drilling heads and CNC-machines, the ideal speeds for drilling and tapping are selected (see our application chart on page 7).

If the same speed is selected for both drilling and tapping, we recommend the values indicated below.

Programming instructions

Countersinking:

Center and countersink simultaneously.

Programming steps for spindle feed and rotation 100 % synchronised (ideal case):

- 1) Combi-drill-tap in rapid to start position
- 2) Drilling:
 - set speed
 - set feed
 - avoid long chips
 - clear shavings
- 3) Tapping section in start position
- 4) Tapping:
 - set speed
 - feed = 100 % pitch
 - set thread depth
 - tap must be free of swarf before starting to cut
- 5) Combi-drill-tap returns to start position.

Programming steps for spindle feed rotation not fully synchronised:









Important: Mount combination drill-tap in chuck with locked pressure spring, but with axial compensation on pull.

- 1) Combi-drill-tap in rapid to start position
- 2) Drilling:
 - set speed
 - set feed
 - avoid long chips
 - clear shavings
- 3) Tapping section in start position
- 4) Tapping:
 - set speed
 - feed = 90 - 95 % pitch
 - set thread depth
- 5) Combi-drill-tap returns to start position.

Cutting and spindle speeds (guide values)

Material groups	Vc (m/min)	Speeds for different diameters										
		M3	M4	M5	M6	M8	M10	M12	M14	M16	M18	M20
Steels up to 500 N/mm ²	20	2120	1600	1270	1060	800	640	530	460	400	360	320
Steels over 500 N/mm ²	15	1600	1200	950	800	600	480	400	340	300	270	240
Cast iron, soft	20	2120	1600	1270	1060	800	640	530	460	400	360	320
Cast iron, hard	15	1600	1200	950	800	600	480	400	340	300	270	240
Brass	25	2650	2000	1600	1330	950	800	660	570	500	450	400
Aluminium	25	2650	2000	1600	1330	950	800	660	570	500	450	400

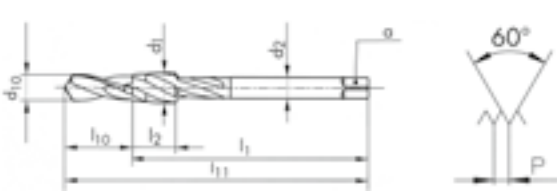



								N5951	N5952	N5951	
N5951											
N5952											
N5951											
											
								ISO 2 6H	ISO 2 6H	7H EN 60423	
∅ d ₁ M	P mm	l ₁₁ mm	l ₂ mm	d ₂ mm	α mm	d ₁₀ mm	l ₁₀ mm	ID			
3	0.50	62.0	12.5	3.5	2.7	2.55	9.0	104578			
4	0.70	66.0	16.0	4.5	3.4	3.36	10.0	104580			
5	0.80	75.5	18.0	6.0	4.9	4.26	12.5	104583			
6	1.00	81.0	20.0	6.0	4.9	5.05	14.0	104585			
8	1.25	93.0	12.0	6.0	4.9	6.80	20.0	104588			
10	1.50	99.0	14.0	7.0	5.5	8.55	22.0	104571			
12	1.75	106.0	16.0	9.0	7.0	10.30	25.0	104573			
16	2.00	123.0	20.0	12.0	9.0	14.10	32.0	104576			
20	2.50	132.0	22.0	16.0	12.0	17.60	36.0	104577			
∅ d ₁ M	P mm	l ₁₁ mm	l ₂ mm	d ₂ mm	α mm	d ₁₀ mm	l ₁₀ mm	ID			
4	0.70	77.0	16.0	4.5	3.4	3.36	21.0	104608			
5	0.80	87.0	18.0	6.0	4.9	4.26	24.0	104609			
6	1.00	94.0	20.0	6.0	4.9	5.05	27.0	104610			
8	1.25	109.0	12.0	6.0	4.9	6.80	36.0	104611			
10	1.50	118.0	14.0	7.0	5.5	8.55	41.0	104603			
∅ d ₁ MF	P mm	l ₁₁ mm	l ₂ mm	d ₂ mm	α mm	d ₁₀ mm	l ₁₀ mm	ID			
4	0.50	66.0	16.0	4.5	3.4	3.55	10.0	* 104579			
5	0.75	75.5	18.0	6.0	4.9	4.31	12.5	* 123379			
8	1.00	93.0	12.0	6.0	4.9	7.05	20.0	104587			
10	1.00	99.0	14.0	7.0	5.5	9.05	22.0	104570			
∅ d ₁ MF	P mm	l ₁₁ mm	l ₂ mm	d ₂ mm	α mm	d ₁₀ mm	l ₁₀ mm	ID			
12	1.50	106.0	16.0	9.0	7.0	10.55	25.0	142825			
16	1.50	123.0	16.0	12.0	9.0	14.55	32.0	142826			
20	1.50	132.0	18.0	16.0	12.0	18.55	36.0	111844			
25	1.50	155.0	22.0	18.0	14.5	23.55	45.0	111845			
32	1.50	170.0	24.0	22.0	18.0	30.55	50.0	111846			

UNC ANSI B1.1 G DIN ISO 228 PG DIN 40430

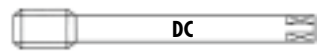
HSSE

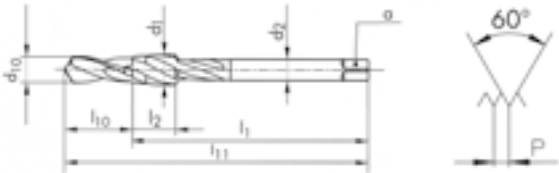
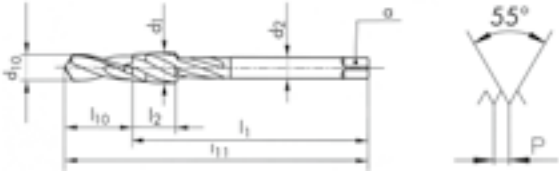
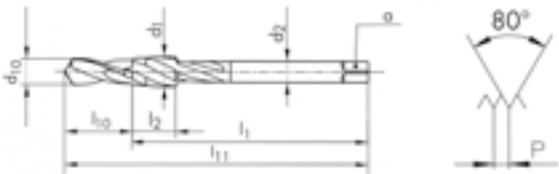

N5951									
									
									
<div style="border: 1px solid black; padding: 5px; display: inline-block;">2B</div>									
									
\varnothing " d ₁	P	d ₁	l ₁₁	l ₂	d ₂	α	d ₁₀	l ₁₀	ID
UNC	TPI	mm	mm	mm	mm	mm	mm	mm	
6	32	3.50	66.0	16.0	4.0	3.0	2.80	10.0	* 104601
10	24	4.82	75.5	18.0	4.5	3.4	3.86	12.5	* 104598
1/4	20	6.35	81.0	20.0	7.0	5.5	5.15	14.0	* 104597
1/2	13	12.70	106.0	16.0	9.0	7.0	10.85	25.0	* 104596
									
\varnothing " d ₁	P	d ₁	l ₁₁	l ₂	d ₂	α	d ₁₀	l ₁₀	ID
G	TPI	mm	mm	mm	mm	mm	mm	mm	
1/8	28	9.72	93.0	12.0	7.0	5.5	8.75	20.0	104567
1/4	19	13.15	106.0	14.0	11.0	9.0	11.75	25.0	104566
3/8	19	16.66	123.0	16.0	12.0	9.0	15.25	32.0	104569
1/2	14	20.95	132.0	18.0	16.0	12.0	19.00	36.0	104565
3/4	14	26.44	155.0	22.0	18.0	14.5	24.45	45.0	* 104568
									
\varnothing d ₁	P	d ₁	l ₁₁	l ₂	d ₂	α	d ₁₀	l ₁₀	ID
PG	TPI	mm	mm	mm	mm	mm	mm	mm	
7	20	12.50	106.0	14.0	9.0	7.0	11.40	25.0	* 104594
9	18	15.20	114.0	15.0	12.0	9.0	13.95	28.0	* 104595
13.5	18	20.40	132.0	18.0	16.0	12.0	19.15	36.0	* 104590
16	18	22.50	142.0	20.0	18.0	14.5	21.25	40.0	* 104591
29	16	37.00	203.0	28.0	28.0	22.0	35.65	63.0	* 104593



编码说明 - CODIFICATION

DC 整体硬质合金螺纹旋风铣刀 DC Solid carbide thread whirl cutters



样例 - Example

螺纹旋风铣刀	Thread whirl cutter	GW					
单刃	Single tooth		10				
单齿, 多刃	Single profile, multi toothed		20				
双齿, 多刃	Double pitch with multi flutes		30				
多刃, 顶面	Multi fluted with full profile		40				
螺纹长度 2.5 x D ₁	Thread length 2.5 x D ₁				16		
螺纹长度 4 x D ₁	Thread length 4 x D ₁				19		
耐磨涂层	Wear-protective coating					VS	
特殊处理	Special execution						SP

DC 整体硬质合金螺纹铣刀 DC Solid carbide thread milling cutters



样例 - Example

标准处理	Standard execution	GF					
适用于淬火钢 (55 - 63 HRC)	For hardened steels (55 - 63 HRC)	GFH					
带 45° 铤孔口倒角	With 45° chamfer for countersinking	GFS					
多样尺寸螺纹铣刀	For multi sizes thread milling cutters	GFM					
钻铣一体螺纹刀具	Thrillers	BGF					
螺旋槽 27° (GF), 10° (GFH)	Spiral flutes 27° (GF), 10° (GFH)		61				
螺旋槽 27° (GFS)	Spiral flutes 27° (GFS)		66				
螺旋槽 15° (GFM)	Spiral flutes 15° (GFM)		62				
2 槽钻铣一体螺纹刀具	Thrillers 2 flutes		67				
3 槽钻铣一体螺纹刀具	Thrillers 3 flutes		68				
外部润滑	External lubrication				1		
内部润滑	Internal lubrication				6		
螺纹长度 1.5 x D ₁	Thread length 1.5 x D ₁					0	
螺纹长度 2 x D ₁	Thread length 2 x D ₁					5	
螺纹长度 2.5 x D ₁	Thread length 2.5 x D ₁					6	
耐磨涂层	Wear-protective coating						VS
特殊处理	Special execution						SP

整体硬质合金螺纹旋风铣刀，整体硬质合金螺纹铣刀和钻铣一体螺纹刀具 SOLID CARBIDE THREAD WHIRL CUTTERS, THREAD MILLING CUTTERS AND THRILLERS

图标说明 - Pictographs



整体硬质合金
Solid carbide



10° 右螺旋槽
10° right hand spiral flutes



15° 右螺旋槽
15° right hand spiral flutes



27° 右螺旋槽
27° right hand spiral flutes



27° 右螺旋槽
27° right hand spiral flutes



带 45° 铤孔口倒角
With 45° chamfer for countersinking



槽数目 (Z)
Number of flutes (Z)



内部冷却
Internal cooling channel



内部冷却 (BGF, 2 槽)
Internal cooling channel (BGF, 2 flutes)



内部冷却 (BGF, 3 槽)
Internal cooling channel (BGF, 3 flutes)



DC 耐磨涂层
DC wear-protective coating



EG 螺丝
Thread EG (for wire screw thread inserts)



螺纹长度 $2.5 \times D_1$
Thread length $2.5 \times D_1$



螺纹长度 $4 \times D_1$
Thread length $4 \times D_1$



底孔直径
Core hole diameter



螺纹长度 $1.5 \times D_1$
Thread length $1.5 \times D_1$



螺纹长度 $2 \times D_1$
Thread length $2 \times D_1$



螺纹长度 $2.5 \times D_1$
Thread length $2.5 \times D_1$



内螺纹
Internal thread



外螺纹
External thread



盲孔 (BGF)
Blind holes (BGF)



通孔 (BGF)
Through holes (BGF)



BGF, 2 槽
BGF, 2 flutes



BGF, 3 槽
BGF, 3 flutes



适用于 ≤ 63 HRC (GFH) 的材料
For materials ≤ 63 HRC (GFH)



锥度螺纹 1:16 (NPT - NPTF - Rc)
Tapered thread 1:16 (NPT - NPTF)



形状精准
Shape accuracy



公差等级 h5
Tolerance class h5



螺旋角
Helix angle



瑞士钟表工业标准
Norm of Swiss Watch Industry

GFM 注意事项



为了防止螺纹形状变形，请保证在加工粗牙螺纹时，刀具直径不超过加工件螺纹直径的三分之二（细牙螺纹：不超过四分之三）



In order to avoid profile defects it is important that the tool diameter does not exceed $\frac{2}{3}$ of the diameter of the work-piece thread for coarse threads ($\frac{3}{4}$ for fine threads).

Notice GFM

产品优势 - ADVANTAGES

GW-GF-GFH-GFS-GFM

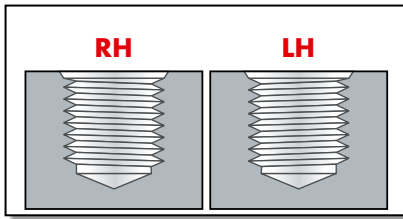

右旋左旋两用刀具
The same cutter can be used for right and left hand threads

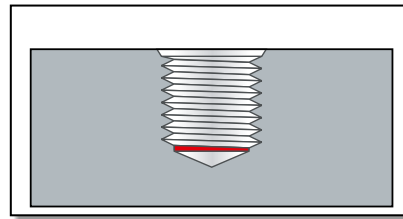

适合铣削接近盲孔底部的螺纹
For threads to be cut near to the bottom of blind holes

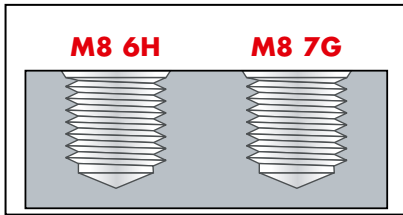

规定公差能按照需要作出调整
Required tolerance adjustable as per users choice

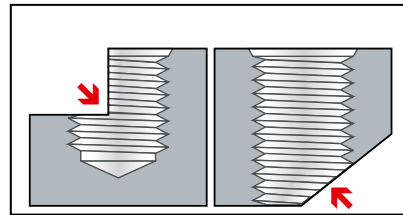

可以加工不完整或断续的螺纹
For threads with interrupted cut or with oblique entrance or exit

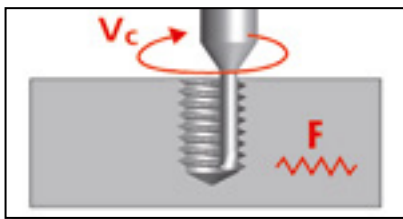

切削速度和进给速度能配合不同加工件作出调整
The cutting speed and feed rate can be matched individually to each work-piece material.

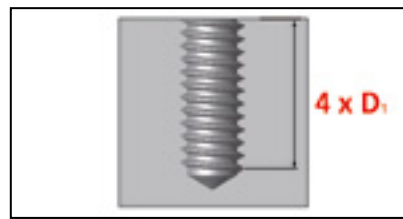

最适合盲孔
Ideal for deep blind holes.

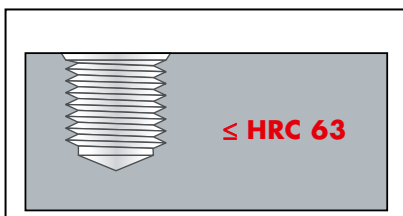

适用于淬火材料的螺纹加工
To realise threads in hardened materials

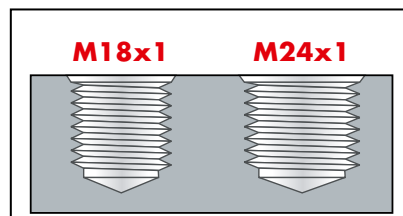

只需要一个刀具就能加工各种直径长度的螺纹
One only tool for threads of a wide range of diameters with the same pitch

BGF

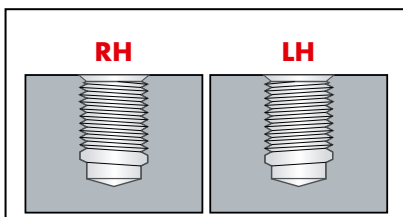

右旋左旋两用刀具
The same cutter can be used for right and left hand threads

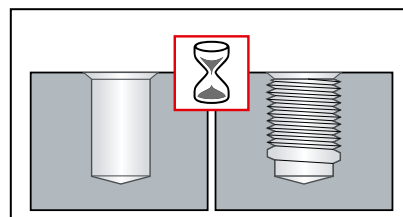

节省刀具更换时间和节省在刀盘里的占用空间
Time-saving when tool changing and space-saving in the tool carousel

循环编程 - PROGRAMMING CYCLE

右旋螺纹顺铣 - Right hand thread climb milling

GW1016
GW1016VS
GW2016
GW2016VS

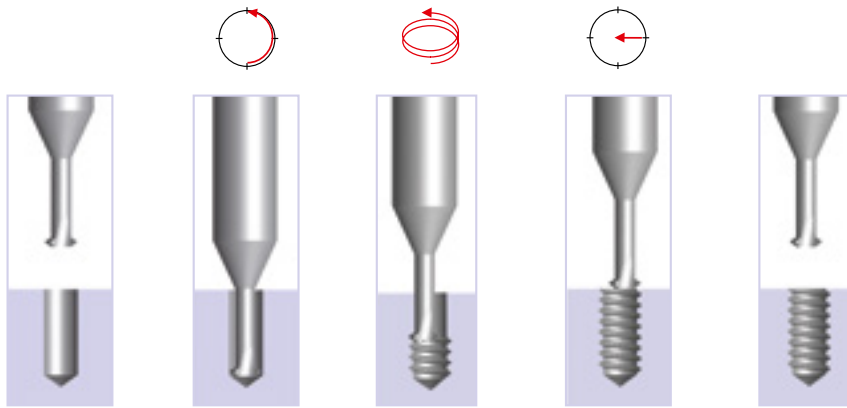

左旋螺纹逆铣 - Conventional right hand thread milling

GW3016
GW3016VS
GW3019
GW3019VS
GW4016
GW4016VS
GW4019
GW4019VS

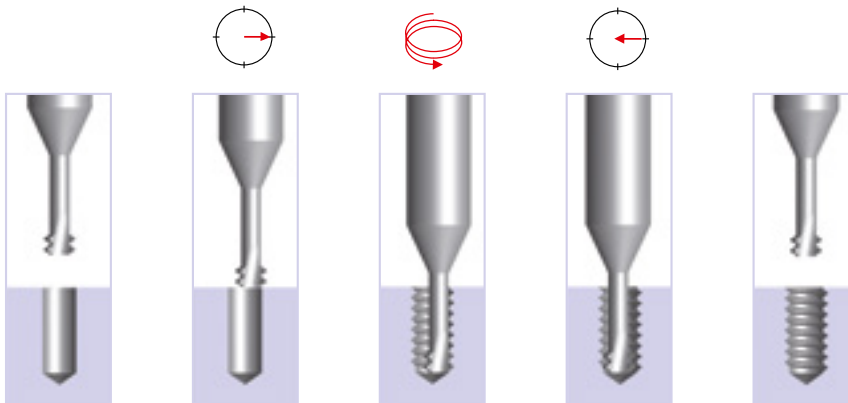

GF 型加工循环 - Operating cycle type GF

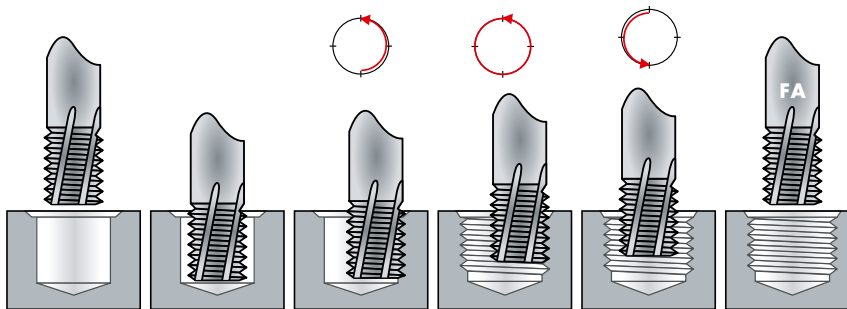

BGF 型加工循环 - Operating cycle type BGF

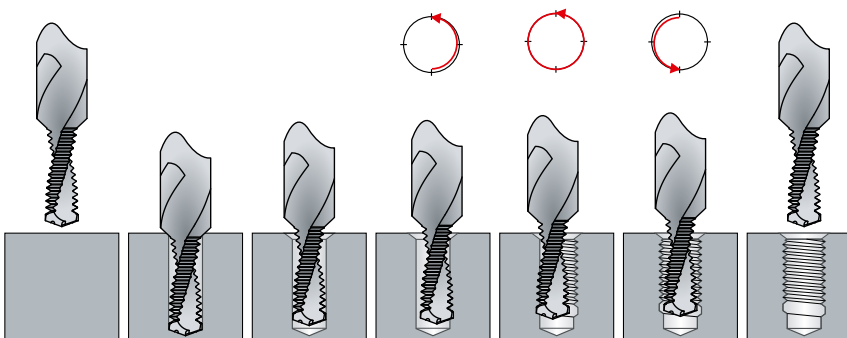

切削速度和进给速度 CUTTING SPEEDS AND FEED RATES

特定加工条件 – Specific requirements

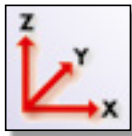

带持续 3-D 路线控制的 CNC 数控机床

CNC machine with 3-D continuous path control



高速切削

High speed cutting

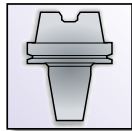

完美同心度夹持系统

Perfect concentricity of fixture

DC 螺纹旋风铣应用图表

DC Application chart for thread whirling

材料分组 Material groups	材料名称	Material designation	硬度 Hardness (HB)	抗拉强度 Tensile strength Rm (N/mm ²)
10 钢材 Steels	11 易切钢	Free-cutting steels	< 200	< 700
	12 结构钢，渗碳钢	Structural / cementation steels	< 200	< 700
	13 碳钢	Carbon steels	< 300	<1000
	14 合金钢 <850 N/mm ²	Alloy steels <850 N/mm ²	< 250	< 850
	15 淬火/回火合金钢 >850 - <1150 N/mm ²	Alloy steels hard./temp. >850 - <1150 N/mm ²	> 250	> 850
	16 高抗拉强度合 <55 HRC	High tensile alloy steels <55 HRC	> 250	> 850
20 不锈钢 Stahl Stainless Steels	21 易切削不锈钢	Free machining stainless steels	< 250	< 850
	22 奥氏体不锈钢	Austenitic stainless steels	< 250	< 850
	23 铁素体和马氏体 <850 N/mm ²	Ferritic and martensitic <850 N/mm ²	< 250	< 850
	24 铁素体和马氏体 >850 - <1150 N/mm ²	Ferritic and martens. >850 - <1150 N/mm ²	> 250	> 850
30 铸铁 Cast iron	31 铸铁	Cast iron	< 250	< 850
	32 球墨 + 可锻	Spheroidal graphite + malleable cast iron	< 250	< 850
40 钛 Titanium	41 纯钛	Pure titanium	< 250	< 850
	42 钛合金	Titanium alloys	> 250	> 850
50 镍 Nickel	51 镍合金 1 <850 N/mm ²	Nickel alloys 1 <850 N/mm ²	< 250	< 850
	52 镍合金 2 >850 - <1150 N/mm ²	Nickel alloys 2 >850 - <1150 N/mm ²	> 250	> 850
	53 镍合金 3 >1150 - ≤1600 N/mm ²	Nickel alloys 3 >1150 - ≤1600 N/mm ²	> 340	> 1150
60 铜 Copper	61 纯铜 (电解铜)	Pure copper (electrolytic copper)	< 120	< 400
	62 短切屑黄铜，磷青铜，炮铜	Short chip brass, phosphor bronze, gun metal	< 200	< 700
	63 长切屑黄铜	Long chip brass	< 200	< 700
70 铝 镁 Aluminium Magnesium	71 纯铝	Al unalloyed	< 100	< 350
	72 铝合金 Si < 1.5 %	Al alloyed Si < 1.5 %	< 150	< 500
	73 铝合金 Si > 1.5 % - < 10 %	Al alloyed Si > 1.5 % - < 10 %	< 120	< 400
	74 铝合金 Si > 10 %，镁合金	Al alloyed Si > 10 %, Mg-Alloys	< 120	< 400
80 塑料合材料 Plastic compounds	81 热塑性塑料	Thermoplastics	-	-
	82 热固性塑料	Duroplastics	-	-
	83 玻璃纤维加强型	Glass fibre reinforced plastics	-	-
90 贵金属 M. Prec.	91 黄金	Yellow gold	-	-
	92 玫瑰金	Red gold	-	-
	93 白金	White gold	-	-
	94 白银	Silver	-	-

使用 – Use

S 使用切削油最佳
S 适合使用切削油

S Optimal with cutting oil
S Suitable with cutting oil

E 使用乳化液最佳
E 适合使用乳化液

E Optimal with emulsion
E Suitable with emulsion

GW



		Vc (m/min)		铣削 fz (mm/齿)		Milling fz (mm/tooth)		
		标准 Standard	带涂层 Coated	Ø 0.3 - 1.0	Ø 1.01 - 3.0	Ø 3.01 - 6.0	Ø 6.01 - 12.0	
GW1016	GW1016S	60 - 80	80 - 100	0.004 - 0.01	0.01 - 0.05	0.04 - 0.10	0.08 - 0.15	11
GW2016	GW2016S	60 - 80	80 - 100	0.004 - 0.01	0.01 - 0.05	0.04 - 0.10	0.08 - 0.15	12
GW3016	GW3016S	50 - 70	70 - 90	0.004 - 0.01	0.01 - 0.05	0.02 - 0.10	0.05 - 0.15	13
GW3016	GW3016S	50 - 70	70 - 90	0.004 - 0.01	0.01 - 0.05	0.02 - 0.10	0.05 - 0.15	14
GW3016	GW3016S	15 - 35	30 - 50	0.004 - 0.01	0.01 - 0.05	0.02 - 0.08	0.04 - 0.15	15
GW3016	GW3016S		15 - 40	0.003 - 0.01	0.006 - 0.03	0.008 - 0.05	0.01 - 0.08	16
GW4016	GW4016S		40 - 60	0.004 - 0.01	0.01 - 0.05	0.02 - 0.10	0.05 - 0.15	21
GW4016	GW4016S		30 - 50	0.004 - 0.01	0.01 - 0.03	0.02 - 0.05	0.03 - 0.08	22
GW4016	GW4016S		30 - 50	0.004 - 0.01	0.01 - 0.03	0.02 - 0.05	0.03 - 0.08	23
GW4016	GW4016S		30 - 50	0.004 - 0.01	0.01 - 0.03	0.02 - 0.05	0.03 - 0.08	24
GW5016	GW5016S	60 - 90	90 - 120	0.004 - 0.01	0.01 - 0.05	0.04 - 0.10	0.08 - 0.15	31
GW5016	GW5016S	50 - 70	70 - 90	0.004 - 0.01	0.01 - 0.05	0.02 - 0.10	0.05 - 0.15	32
GW6016	GW6016S	15 - 35	20 - 40	0.004 - 0.01	0.01 - 0.03	0.02 - 0.05	0.03 - 0.08	41
GW6016	GW6016S	10 - 30	15 - 35	0.004 - 0.01	0.01 - 0.03	0.02 - 0.05	0.03 - 0.08	42
GW7016	GW7016S		20 - 40	0.004 - 0.01	0.01 - 0.03	0.02 - 0.05	0.03 - 0.08	51
GW7016	GW7016S		20 - 40	0.004 - 0.01	0.01 - 0.03	0.02 - 0.05	0.03 - 0.08	52
GW7016	GW7016S		20 - 30	0.003 - 0.01	0.006 - 0.03	0.008 - 0.05	0.01 - 0.08	53
GW8016	GW8016S	150 - 200	200 - 250	0.004 - 0.01	0.01 - 0.05	0.02 - 0.10	0.05 - 0.15	61
GW8016	GW8016S	100 - 150	150 - 200	0.004 - 0.01	0.01 - 0.05	0.04 - 0.10	0.08 - 0.15	62
GW8016	GW8016S	100 - 150	150 - 200	0.004 - 0.01	0.01 - 0.05	0.02 - 0.10	0.05 - 0.15	63
GW9016	GW9016S	150 - 250		0.004 - 0.01	0.01 - 0.05	0.05 - 0.10	0.10 - 0.20	71
GW9016	GW9016S	150 - 250		0.004 - 0.01	0.01 - 0.05	0.05 - 0.10	0.10 - 0.20	72
GW9016	GW9016S	150 - 250	200 - 300	0.004 - 0.01	0.01 - 0.05	0.05 - 0.10	0.10 - 0.20	73
GW9016	GW9016S	150 - 250	200 - 300	0.004 - 0.01	0.01 - 0.05	0.04 - 0.10	0.08 - 0.15	74
GW10016	GW10016S	150 - 250	200 - 300	0.004 - 0.01	0.01 - 0.05	0.05 - 0.10	0.10 - 0.20	81
GW10016	GW10016S	80 - 150	100 - 200	0.004 - 0.01	0.01 - 0.05	0.04 - 0.10	0.08 - 0.15	82
GW10016	GW10016S		80 - 100	0.004 - 0.01	0.01 - 0.05	0.04 - 0.10	0.08 - 0.15	83
GW11016	GW11016S	100 - 150	150 - 200	0.004 - 0.01	0.01 - 0.05	0.04 - 0.10	0.08 - 0.15	91
GW11016	GW11016S	60 - 90	90 - 120	0.004 - 0.01	0.01 - 0.05	0.02 - 0.10	0.04 - 0.15	92
GW11016	GW11016S		30 - 50	0.004 - 0.01	0.01 - 0.03	0.02 - 0.05	0.03 - 0.08	93
GW11016	GW11016S	60 - 90	90 - 120	0.004 - 0.01	0.01 - 0.05	0.02 - 0.10	0.04 - 0.15	94

以上数据仅供参考。

The indicated values are a guideline.

DC 螺纹旋风铣刀和螺纹铣刀应用图表

DC Application chart for thread milling cutters and thrillers

材料分组 Material groups	材料名称 应用分组样例在 5 - 6 页.	Material designation Examples for application groups, pag. 5 - 6.	硬度 Hardness (HB)	抗拉强度 Tensile strength Rm (N/mm ²)
10 钢材 Steels	11 易切钢	Free-cutting steels	< 200	< 700
	12 结构钢, 渗碳钢	Structural / cementation steels	< 200	< 700
	13 碳钢	Carbon steels	< 300	< 1000
	14 合金钢 <850 N/mm ²	Alloy steels <850 N/mm ²	< 250	< 850
	15 淬火/回火合金钢 >850 - <1150 N/mm ²	Alloy steels hard. / temp. >850 - <1150 N/mm ²	> 250	> 850
	16 高抗拉强度合金钢	High tensile alloy steels	> 250	> 850
	* 高抗拉强度合金钢 55 - 63 HRC	High tensile alloy steels 55 - 63 HRC	> 560	> 2000
20 不锈钢 Stainless Steels	21 易切削不锈钢	Free machining stainless steels	< 250	< 850
	22 奥氏体不锈钢	Austenitic stainless steels	< 250	< 850
	23 铁素体和马氏体 <850 N/mm ²	Ferritic and martensitic <850 N/mm ²	< 250	< 850
	24 铁素体和马氏体 >850 - <1150 N/mm ²	Ferritic and martens. >850 - <1150 N/mm ²	> 250	> 850
30 铸铁 Cast iron	31 铸铁	Cast iron	< 250	< 850
	32 球墨 + 可锻铸铁	Spheroidal graphite + malleable cast iron	< 250	< 850
40 钛 Titanium	41 纯钛	Pure titanium	< 250	< 850
	42 钛合金	Titanium alloys	> 250	> 850
50 镍 Nickel	51 镍合金 1 <850 N/mm ²	Nickel alloys 1 <850 N/mm ²	< 250	< 850
	52 镍合金 2 >850 - <1150 N/mm ²	Nickel alloys 2 >850 - <1150 N/mm ²	> 250	> 850
	53 镍合金 3 >1150 - ≤1600 N/mm ²	Nickel alloys 3 >1150 - ≤1600 N/mm ²	> 340	> 1150
60 铜 Copper	61 纯铜 (电解铜)	Pure copper (electrolytic copper)	< 120	< 400
	62 短切屑黄铜, 磷青铜, 炮铜	Short chip brass, phosphor bronze, gun metal	< 200	< 700
	63 长切屑黄铜	Long chip brass	< 200	< 700
70 铝 镁 Aluminium Magnesium	71 纯铝	Al / Mg unalloyed	< 100	< 350
	72 铝合金 Si < 1.5 %	Al alloyed Si < 1.5 %	< 150	< 500
	73 铝合金 Si > 1.5 % - < 10 %	Al alloyed Si > 1.5 % - < 10 %	< 120	< 400
	74 铝合金 Si > 10 %, 镁合金	Al alloyed Si > 10 %, Mg-Alloys	< 120	< 400
80 塑料合成材料 Plastic compounds	81 热塑性塑料	Thermoplastics	-	-
	82 热固性塑料	Duroplastics	-	-
	83 玻璃纤维加强型塑料	Glass fibre reinforced plastics	-	-

* GFH 型螺纹铣刀

Thread milling cutter type GFH

螺纹铣削进给

进给速度

$$V_{fk} = f_z \times Z \times n$$

中心进给速度

$$V_{fm} = \frac{V_{fk}}{d} \times (\text{螺纹公称直径} - \text{螺纹铣刀直径})$$

螺纹公称直径

如果cnc数控机床不自动计算刀具中心的进给速度, 请计算中心进给度。

Thread milling feed rates

Feed rate

$$V_{fk} = f_z \times Z \times n$$

Feed rate of the tool middle

$$V_{fm} = \frac{V_{fk}}{d} \times (\text{nominal thread } \varnothing - \varnothing \text{ of the thread milling cutter})$$

nominal thread \varnothing

On CNC machines, which do not calculate for themselves the feed rate at the tool-centre, the value "centre of the tool V_{fm} " must be considered.

螺纹旋风铣刀 Thread milling cutters

切削速度 Vc (m/min)		进给速度 fz (mm/齿) Rate of feed fz (mm/tooth)
标准 Standard	带涂层 VS Coated VS	
50 - 100	80 - 150	0.04 - 0.15
40 - 80	60 - 120	0.04 - 0.15
40 - 80	60 - 120	0.02 - 0.10
40 - 80	60 - 120	0.02 - 0.10
30 - 60	50 - 90	0.02 - 0.08
20 - 40	30 - 60	0.01 - 0.05
10 - 30	20 - 40	0.005 - 0.02
30 - 60	50 - 90	0.02 - 0.10
20 - 40	30 - 60	0.01 - 0.05
30 - 60	50 - 90	0.02 - 0.08
20 - 40	30 - 60	0.01 - 0.05
50 - 100	80 - 150	0.05 - 0.15
50 - 80	80 - 120	0.02 - 0.10
40 - 70	60 - 100	0.02 - 0.08
20 - 40	30 - 60	0.01 - 0.05
20 - 40	30 - 60	0.02 - 0.08
20 - 40	30 - 60	0.02 - 0.08
10 - 20	20 - 30	0.005 - 0.02
150 - 200	200 - 250	0.05 - 0.15
150 - 200	200 - 250	0.05 - 0.15
150 - 200	200 - 250	0.05 - 0.15
100 - 250	150 - 300	0.05 - 0.20
100 - 250	150 - 300	0.05 - 0.20
100 - 250	150 - 300	0.05 - 0.20
100 - 250	150 - 300	0.05 - 0.20
100 - 250	150 - 300	0.05 - 0.15
100 - 200	150 - 300	0.05 - 0.20
50 - 100	80 - 150	0.04 - 0.15
60 - 80	80 - 120	0.04 - 0.15

钻铣一体螺纹刀具 Thrillers

切削速度 Vc (m/min)		钻削 f (mm/圈) Drilling f (mm/rev.)	铣削 fz (mm/齿) Milling fz (mm/tooth)
标准 Standard	带涂层 VS Coated VS		
50 - 100	80 - 150	0.1 - 0.3	0.05 - 0.15
50 - 80	80 - 120	0.1 - 0.2	0.02 - 0.10
100 - 250	150 - 300	0.1 - 0.4	0.05 - 0.20
100 - 250	150 - 300	0.1 - 0.4	0.05 - 0.20
100 - 250	150 - 300	0.1 - 0.4	0.05 - 0.20
100 - 250	150 - 300	0.1 - 0.4	0.05 - 0.20
100 - 250	150 - 300	0.1 - 0.4	0.05 - 0.20
100 - 200	150 - 250	0.1 - 0.3	0.05 - 0.15

以上数据仅供参考。 The indicated values are a guideline.











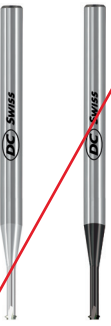

技术注意事项

- △ 加工长切屑材料时，可能需要多次清理毛刺。
- △ 请在要使用 BGF 型刀具加工没有相关加工数据的材料前，向 DC SWISS SA 咨询。

Technical notes





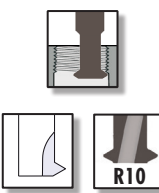
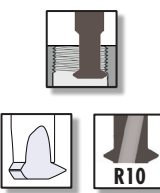
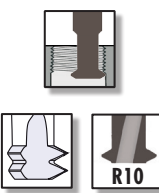
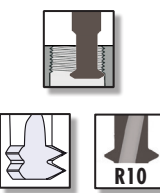
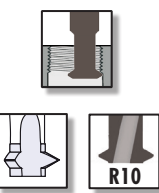
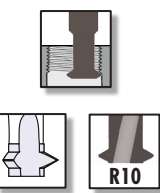



- △ When machining long chipping materials, they may require deburring operations.
- △ Please ask DC SWISS SA before using BGF type thrillers in materials where no cutting data is given.

目录 - GW 型整体硬质合金螺纹旋风铣刀
 Directory - Solid carbide thread whirl cutters type GW























													
类型 Type		GW1016	GW1016VS	GW2016	GW2016VS	GW3016	GW3016VS	GW3019	GW3019VS	GW4016*	GW4016VS*	GW4019*	GW4019VS*
涂层 Coating			VS		VS		VS		VS		VS		VS
													
螺纹长度 Thread length													
特点 Characteristics													
M	ISO DIN 13 ISO DIN 14			207		208/209		208/209		212		212	
MF	ISO DIN 13					208/209		208/209					
UNC	ANSI B1.1					210		210		213		213	
UNF	ANSI B1.1					211		211		213		213	
S	NIHS	206		207									

目录 - GF 型整体硬质合金螺纹铣刀

Directory - Solid carbide thread milling cutters type GF

		GF											
类型 Type		GF6110		GF6160		GF6115		GF6165		GF6116		GF6166	
涂层 Coating		VS		VS		VS		VS		VS		VS	
螺纹长度 Thread length													
特点 Characteristics													
M	ISO DIN 13	214				215		215		216		216	
MF	ISO DIN 13	217						218				218	
UNC	ANSI B1.1	219						220				220	
UNF	ANSI B1.1	221						222				222	
UN	ANSI B1.1												
G (BSP)	DIN ISO 228							223				223	
PG	DIN 40430												
NPT	ANSI B1.20.1			224									
NPTF	ANSI B1.20.3			224									
EG M	DIN 8140												

目录 - GFH 型 and GFS 型整体硬质合金螺纹铣刀
 Directory - Solid carbide thread milling cutters type GFH and GFS

		GFH		GFS							
类型 Type		GFH6110VS	GFS6610 GFS6610VS	GFS6660 GFS6660VS	GFS6615 GFS6615VS	GFS6665 GFS6665VS	GFS6616 GFS6616VS	GFS6666 GFS6666VS	GFS6616 GFS6616VS	GFS6666 GFS6666VS	
涂层 Coating											
螺纹长度 Thread length											
特点 Characteristics											
M	ISO DIN 13	214	225	225	226	226		226		227	
MF	ISO DIN 13		228	228	229	229		229			
UNC	ANSI B1.1		230	230	231	231		231			
UNF	ANSI B1.1		232	232	233	233		233			
UN/EF/S	ANSI B1.1										
G (BSP)	DIN ISO 228			234				234			
PG	DIN 40430										
NPT	ANSI B1.20.1			235							
NPTF	ANSI B1.20.3			235							
EG M	DIN 8140										

目录 - 整体硬质合金螺纹铣刀, GFM型和 BGF型钻铣一体螺纹刀具
 Directory - Solid carbide thread milling cutters and thrillers type GFM and BGF

		GFM		BGF									
GFS6666	GFS6666VS	GFM6260	GFM6260VS	BGF6760	BGF6760VS	BGF6765	BGF6765VS	BGF6766	BGF6766VS	BGF6865	BGF6865VS	BGF6866	BGF6866VS
VS		VS		VS		VS		VS		VS		VS	
227		236		240		241		241		242		242	
		236		243		243							
		237											
		237											
		237											
		238											
		239											
		239											

GW

GW1016



GW1016VS



GW1016

GW1016VS

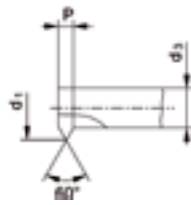
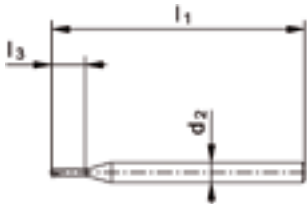

$\varnothing D_1$ S	P mm	d_1 mm	l_1 mm	l_3 mm	d_2 h5 mm	d_3 mm		
0.3	0.08	0.21	39	0.9	3	0.10	1	0.23 *
0.4	0.10	0.29	39	1.2	3	0.15	1	0.32 *
0.5	0.125	0.36	39	1.5	3	0.19	1	0.40 *
0.6	0.15	0.43	39	1.7	3	0.23	1	0.48 *
0.7	0.175	0.50	39	2.0	3	0.27	1	0.56 *
0.8	0.20	0.57	39	2.3	3	0.31	1	0.64 *
0.9	0.225	0.64	39	2.6	3	0.34	1	0.72 *
1.0	0.25	0.71	39	2.9	3	0.38	1	0.80 *
1.2	0.25	0.91	39	3.4	3	0.58	1	1.00 *
1.4	0.30	1.06	39	3.9	3	0.66	1	1.15 *

ID

ID

166930

166940

166931

166941

166932

166942

166933

166943

166934

166944

166935

166945

166936

166946

166937

166947

166938

166948

166939

166949

*Tol. +0.02 mm
0

GW

GW2016



GW2016VS



GW2016

GW2016VS

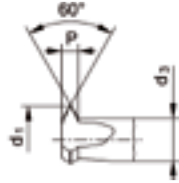
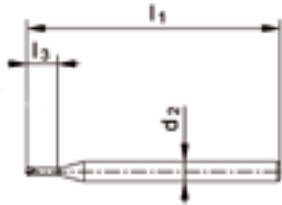

∅ D ₁	P	d ₁	l ₁	l ₃	d ₂ h5	d ₃		
S	mm	mm	mm	mm	mm	mm		→ ←

0.8	0.20	0.57	39	2.3	3	0.29	3	0.64 *
0.9	0.225	0.64	39	2.6	3	0.33	3	0.72 *
1.0	0.25	0.71	39	2.9	3	0.36	3	0.80 *
1.2	0.25	0.91	39	3.4	3	0.56	3	1.00 *
1.4	0.30	1.06	39	3.9	3	0.64	3	1.15 *

ID

ID

166969	166988
166970	166989
166971	166990
166972	166991
166973	166992

∅ D ₁	P	d ₁	l ₁	l ₃	d ₂ h5	d ₃		
M	mm	mm	mm	mm	mm	mm		→ ←

0.8	0.20	0.57	39	2.3	3	0.29	3	0.62
0.9	0.225	0.64	39	2.6	3	0.33	3	0.70
1.0	0.25	0.71	39	2.9	3	0.36	3	0.75
1.2	0.25	0.91	39	3.4	3	0.56	3	0.95
1.4	0.30	1.06	39	3.9	3	0.64	3	1.10
1.6	0.35	1.20	39	4.5	3	0.71	3	1.25
1.8	0.35	1.40	39	5.0	3	0.91	3	1.45
2.0	0.40	1.54	39	5.6	3	0.98	3	1.60
2.5	0.45	1.98	39	6.9	3	1.35	3	2.05
3.0	0.50	2.43	51	8.4	5	1.73	4	2.50
3.5	0.60	2.81	51	9.9	5	1.97	4	2.90
4.0	0.70	3.20	51	11.3	5	2.22	4	3.30
5.0	0.80	4.08	51	14.0	5	2.96	4	4.20
6.0	1.00	4.90	51	16.8	5	3.50	4	5.00

ID

ID

166974	166993
166975	166994
166976	166995
166977	166996
166978	166997
166979	166998
166980	166999
166981	167000
166982	167001
166983	167002
166984	167003
166985	167004
166986	167005
166987	167006

*Tol. +0.02 mm
0

GW

GW3016



GW3016VS



GW3019



GW3019VS

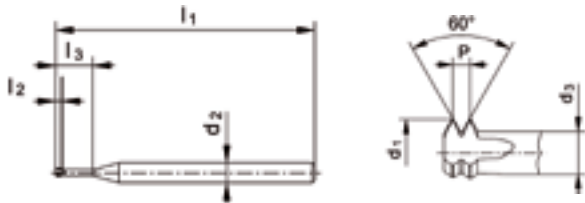

GW3016

GW3016VS

GW3019

GW3019VS



$\varnothing D_1$ M, MF	P	d_1	l_1	l_3	d_2 h5	d_3		
----------------------------	---	-------	-------	-------	----------	-------	--	--

0.8	0.20	0.57	39	2.3	3	0.29	3	0.62
0.9	0.225	0.64	39	2.6	3	0.33	3	0.70
1.0	0.25	0.71	39	2.9	3	0.36	3	0.75
1.2	0.25	0.91	39	3.4	3	0.56	3	0.95
1.4	0.30	1.06	39	3.9	3	0.64	3	1.10
1.6	0.35	1.20	39	4.5	3	0.71	3	1.25
1.8	0.35	1.40	39	5.0	3	0.91	3	1.45
2.0	0.20	1.77	39	5.3	3	1.49	3	1.80
2.0	0.40	1.54	39	5.6	3	0.98	3	1.60
2.5	0.20	2.27	39	6.6	3	1.99	3	2.30
2.5	0.25	2.21	39	6.6	3	1.86	3	2.25
2.5	0.45	1.98	39	6.9	3	1.35	3	2.05

ID

ID

167021	167035
167022	167036
167023	167037
167024	167038
167025	167039
167026	167040
167027	167041
175225	171442
167028	167042
175226	175241
175227	167299
167029	167043

$\varnothing D_1$ M, MF	P	d_1	l_1	l_3	d_2 h5	d_3		
----------------------------	---	-------	-------	-------	----------	-------	--	--

0.8	0.20	0.57	39	3.5	3	0.29	3	0.62
0.9	0.225	0.64	39	3.9	3	0.33	3	0.70
1.0	0.25	0.71	39	4.4	3	0.36	3	0.75
1.2	0.25	0.91	39	5.2	3	0.56	3	0.95
1.4	0.30	1.06	39	6.0	3	0.64	3	1.10
1.6	0.35	1.20	39	6.9	3	0.71	3	1.25
1.8	0.35	1.40	39	7.7	3	0.91	3	1.45
2.0	0.20	1.77	39	8.3	3	1.49	3	1.80
2.0	0.40	1.54	39	8.6	3	0.98	3	1.60
2.5	0.20	2.27	39	10.3	3	1.99	3	2.30
2.5	0.25	2.21	39	10.4	3	1.86	3	2.25
2.5	0.45	1.98	39	10.6	3	1.35	3	2.05

ID

ID

167063	167077
167064	167078
167065	167079
167066	167080
167067	167081
167068	167082
167069	167083
175254	175270
167070	167084
175255	175271
175256	175272
167071	167085

M, MF ISO DIN 13



h5

GW

GW3016



R10

GW3016VS



R10

VS

GW3019



R10

GW3019VS



R10

VS

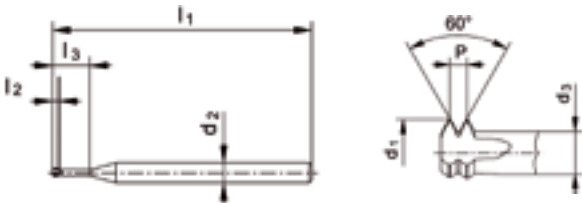

GW3016

GW3016VS

GW3019

GW3019VS



$\varnothing D_1$ M, MF	P mm	d_1 mm	l_1 mm	l_3 mm	d_2 h5 mm	d_3 mm		
3.0	0.35	2.60	51	8.2	5	2.11	4	2.65
3.0	0.50	2.43	51	8.4	5	1.73	4	2.50
3.5	0.60	2.81	51	9.9	5	1.97	4	2.90
4.0	0.70	3.20	51	11.3	5	2.22	4	3.30
5.0	0.80	4.08	51	14.0	5	2.96	4	4.20
6.0	1.00	4.85	51	16.8	5	3.45	4	5.00
8.0	1.25	5.95	63	23.0	6*	4.20	5	6.80
10.0	1.50	7.95	67	28.0	8*	5.85	5	8.50
12.0	1.75	9.95	76	34.0	10*	7.50	5	10.20

ID

ID

175228	175242
167030	167044
167031	167045
167032	167046
167033	167047
167034	167048
175229	175243
175230	175244
175231	175245

$\varnothing D_1$ M, MF	P mm	d_1 mm	l_1 mm	l_3 mm	d_2 h5 mm	d_3 mm		
3.0	0.35	2.60	51	12.7	5	2.11	4	2.65
3.0	0.50	2.43	51	12.9	5	1.73	4	2.50
3.5	0.60	2.81	51	15.1	5	1.97	4	2.90
4.0	0.70	3.20	51	17.3	5	2.22	4	3.30
5.0	0.80	4.08	51	21.5	5	2.96	4	4.20
6.0	1.00	4.85	51	25.8	5	3.45	4	5.00
8.0	1.25	5.95	75	35.0	6*	4.20	5	6.80
10.0	1.50	7.95	83	43.0	8*	5.85	5	8.50
12.0	1.75	9.95	95	52.0	10*	7.50	5	10.20

ID

ID

175257	175273
167072	167086
167073	167087
167074	167088
167075	167089
167076	167090
175258	175274
175259	175275
175260	175276

*Tol. h6

GW

GW3016



GW3016VS



GW3019



GW3019VS

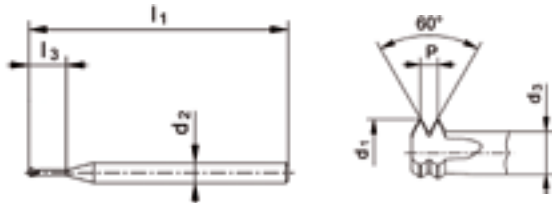

GW3016

GW3016VS

GW3019

GW3019VS



$\varnothing D_1$ UNC	P TPI	d_1 mm	l_1 mm	l_3 mm	d_2 h5 mm	d_3 mm		
2	56	1.66	39	6.1	3	1.02	3	1.75
4	40	2.11	39	8.0	3	1.22	3	2.25
6	32	2.59	51	10.2	5	1.48	4	2.75
8	32	3.25	51	11.9	5	2.14	4	3.40
10	24	3.60	51	14.0	5	2.12	4	3.80
1/4	20	4.89	51	18.2	5	3.11	4	5.10
5/16	18	5.95	63	23.0	6*	3.97	5	6.50
3/8	16	7.10	67	27.0	8*	4.87	5	8.00
1/2	13	9.95	76	36.0	10*	7.21	5	10.80

ID

ID

167472	167500
167473	167501
167474	167502
167475	167503
173983	173986
167476	167504
175232	175246
175233	173546
175234	175247

$\varnothing D_1$ UNC	P TPI	d_1 mm	l_1 mm	l_3 mm	d_2 h5 mm	d_3 mm		
2	56	1.66	39	9.4	3	1.02	3	1.75
4	40	2.11	39	12.2	3	1.22	3	2.25
6	32	2.59	51	15.5	5	1.48	4	2.75
8	32	3.25	51	18.1	5	2.14	4	3.40
10	24	3.60	51	21.3	5	2.12	4	3.80
1/4	20	4.89	51	27.7	5	3.11	4	5.10
5/16	18	5.95	75	35.0	6*	3.97	5	6.50
3/8	16	7.10	83	41.0	8*	4.87	5	8.00
1/2	13	9.95	95	55.0	10*	7.21	5	10.80

ID

ID

167479	167507
167480	167508
167481	167509
167482	167510
173982	173979
167483	167511
175261	175277
175262	175278
175263	175279

*Tol. h6

UNF ANSI B1.1

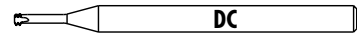

h5

GW

GW3016 GW3016VS GW3019 GW3019VS

GW3016



GW3016VS



GW3019



GW3019VS



GW

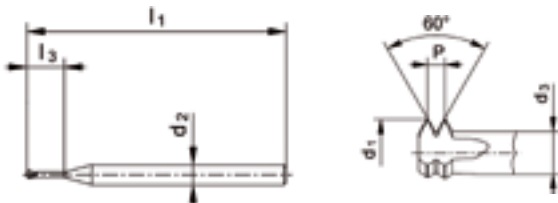

$\varnothing D_1$ UNF	P TPI	d_1 mm	l_1 mm	l_3 mm	d_2 h5 mm	d_3 mm		
0	80	1.15	39	4.3	3	0.71	3	1.20
1	72	1.44	39	5.1	3	0.95	3	1.50
4	48	2.23	39	7.9	3	1.49	3	2.35
8	36	3.35	51	11.7	5	2.36	4	3.50
10	32	3.91	51	13.5	5	2.80	4	4.05
1/4	28	4.95	51	17.6	5	3.68	4	5.50
5/16	24	5.95	63	22.0	6*	4.47	5	6.90
3/8	24	7.10	67	26.0	8*	5.62	5	8.50

ID	ID
175235	175248
175236	175249
175237	175250
175238	175251
167477	167505
167478	167506
175239	175252
175240	175253

$\varnothing D_1$ UNF	P TPI	d_1 mm	l_1 mm	l_3 mm	d_2 h5 mm	d_3 mm		
0	80	1.15	39	6.6	3	0.71	3	1.20
1	72	1.44	39	7.9	3	0.95	3	1.50
4	48	2.23	39	12.1	3	1.49	3	2.35
8	36	3.35	51	18.0	5	2.36	4	3.50
10	32	3.91	51	20.8	5	2.80	4	4.05
1/4	28	4.95	51	27.1	5	3.68	4	5.50
5/16	24	5.95	75	34.0	6*	4.47	5	6.90
3/8	24	7.10	83	40.0	8*	5.62	5	8.50

ID	ID
175264	175280
175265	175281
175266	172376
175267	175282
167484	167512
167485	167513
175268	175283
175269	175284

*Tol. h6

GW

GW4016



GW4016VS



GW4019



GW4019VS

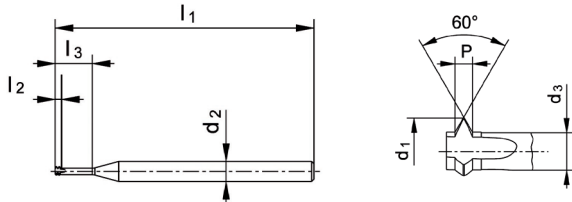

GW4016*

GW4016VS*

GW4019*

GW4019VS*



$\varnothing D_1$ M	P mm	d_1 mm	l_1 mm	l_2 mm	l_3 mm	d_2 mm	h_5 mm	d_3 mm			ID	ID
0.8	0.20	0.51	39	0.40	2.3	3	0.23	3	0.58*		167105	167119
0.9	0.225	0.57	39	0.45	2.6	3	0.26	3	0.65*		167106	167120
1.0	0.25	0.64	39	0.50	2.9	3	0.29	3	0.70*		167107	167121
1.2	0.25	0.84	39	0.50	3.4	3	0.49	3	0.90*		167108	167122
1.4	0.30	0.97	39	0.60	4.0	3	0.55	3	1.05*		167109	167123
1.6	0.35	1.09	39	0.70	4.6	3	0.60	3	1.19*		167110	167124
1.8	0.35	1.29	39	0.70	5.1	3	0.80	3	1.39*		167111	167125
2.0	0.40	1.42	39	0.80	5.6	3	0.86	3	1.54*		167112	167126
2.5	0.45	1.85	39	0.90	7.0	3	1.22	3	1.98*		167113	167127
3.0	0.50	2.28	51	1.00	8.5	5	1.58	4	2.43*		167114	167128
3.5	0.60	2.63	51	1.20	10.0	5	1.79	4	2.80*		167115	167129
4.0	0.70	2.99	51	1.40	11.4	5	2.01	4	3.20*		167116	167130
5.0	0.80	3.84	51	1.60	14.1	5	2.72	4	4.10*		167117	167131
6.0	1.00	4.55	51	2.00	17.0	5	3.15	4	4.90*		167118	167132
<hr/>												
$\varnothing D_1$ M	P mm	d_1 mm	l_1 mm	l_2 mm	l_3 mm	d_2 mm	h_5 mm	d_3 mm			ID	ID
0.8	0.20	0.51	39	0.40	3.5	3	0.23	3	0.58*		167147	167161
0.9	0.225	0.57	39	0.45	4.0	3	0.26	3	0.65*		167148	167162
1.0	0.25	0.64	39	0.50	4.4	3	0.29	3	0.70*		167149	167163
1.2	0.25	0.84	39	0.50	5.2	3	0.49	3	0.90*		167150	167164
1.4	0.30	0.97	39	0.60	6.1	3	0.55	3	1.05*		167151	167165
1.6	0.35	1.09	39	0.70	7.0	3	0.60	3	1.19*		167152	167166
1.8	0.35	1.29	39	0.70	7.8	3	0.80	3	1.39*		167153	167167
2.0	0.40	1.42	39	0.80	8.6	3	0.86	3	1.54*		167154	167168
2.5	0.45	1.85	39	0.90	10.7	3	1.22	3	1.98*		167155	167169
3.0	0.50	2.28	51	1.00	13.0	5	1.58	4	2.43*		167156	167170
3.5	0.60	2.63	51	1.20	15.2	5	1.79	4	2.80*		167157	167171
4.0	0.70	2.99	51	1.40	17.4	5	2.01	4	3.20*		167158	167172
5.0	0.80	3.84	51	1.60	21.6	5	2.72	4	4.10*		167159	167173
6.0	1.00	4.55	51	2.00	26.0	5	3.15	4	4.90*		167160	167174

*Tol. +0.03 mm
0

UNC-UNF ANSI B1.1

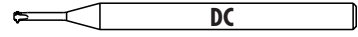

h5

GW

GW4016



GW4016VS



GW4019



GW4019VS

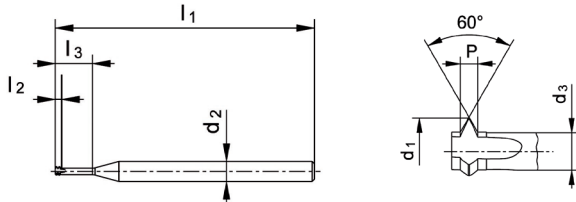

GW4016* **GW4016VS*** **GW4019*** **GW4019VS***



$\varnothing'' D_1$ UNC	P TPI	d_1 mm	l_1 mm	l_2 mm	l_3 mm	d_2 h5 mm	d_3 mm		
2	56	1.52	39	0.91	6.2	3	0.89	3	1.65*
4	40	1.92	39	1.27	8.1	3	1.03	3	2.10*
6	32	2.35	51	1.59	10.4	5	1.24	4	2.60*
1/4	20	4.51	51	2.54	18.5	5	2.73	4	5.00*

ID	ID
167486	167514
167487	167515
167488	167516
167490	167518

$\varnothing'' D_1$ UNF	P TPI	d_1 mm	l_1 mm	l_2 mm	l_3 mm	d_2 h5 mm	d_3 mm		
10	32	3.67	51	1.59	13.7	5	2.56	4	3.95*
1/4	28	4.95	51	1.81	17.7	5	3.68	4	5.35*

ID	ID
167491	167519
167492	167520

$\varnothing'' D_1$ UNC	P TPI	d_1 mm	l_1 mm	l_2 mm	l_3 mm	d_2 h5 mm	d_3 mm		
2	56	1.52	39	0.90	9.5	3	0.89	3	1.65*
4	40	1.92	39	1.27	12.4	3	1.03	3	2.10*
6	32	2.35	51	1.59	15.6	5	1.24	4	2.60*
1/4	20	4.51	51	2.54	28.0	5	2.73	4	5.00*

ID	ID
167493	167521
167494	167522
167495	167523
167497	167525

$\varnothing'' D_1$ UNF	P TPI	d_1 mm	l_1 mm	l_2 mm	l_3 mm	d_2 h5 mm	d_3 mm		
10	32	3.67	51	1.59	20.9	5	2.56	4	3.95*
1/4	28	4.95	51	1.81	27.3	5	3.68	4	5.35*

ID	ID
167498	167526
167499	167527

*Tol. $\begin{matrix} +0.03 \text{ mm} \\ 0 \end{matrix}$

*被 GW4116/ GW4119 替代
Replaced by GW4116/ GW4119



GF - GFH

GF6110

GF6110VS

VS
GFH6110VS

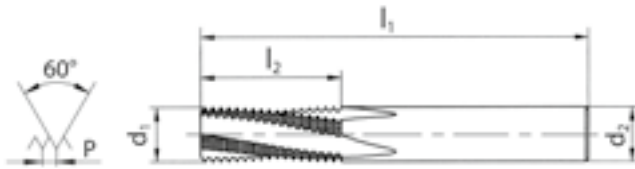
VS

GF6110
GF6110VS
GFH6110VS

**HRC
≤ 63**

∅ D ₁ M	P mm	d ₁ mm	l ₁ mm	l ₂ mm	d ₂ mm	GF	GFH		ID	ID	ID
2	0.40	1.50	48	3.4	6	2		1.60	125233	115993	
2.5	0.45	1.90	48	4.3	6	3		2.05	150565	152124	
3	0.50	2.30	48	5.3	6	3	3	2.50	125660	116395	150072
3.5	0.60	2.70	48	6.3	6	3		2.90	116350	135217	
4	0.70	3.00	48	7.4	6	3	3	3.30	125944	116396	150073
5	0.80	3.80	48	9.2	6	3	4	4.20	126158	116397	150074
6	1.00	4.50	54	10.5	6		4	5.00			150075
8	1.25	5.95	54	13.1	6		5	6.80			150076
10	1.50	7.95	64	17.3	8		5	8.50			150077
12	1.75	9.95	74	20.1	10		5	10.20			151326



GF

GF6115



GF6115VS



VS

GF6165



GF6165VS



VS

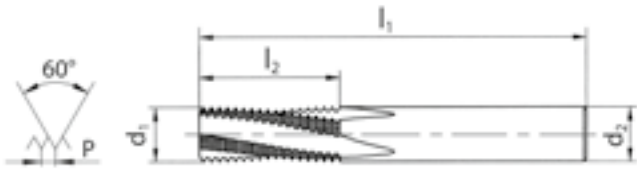

GF6115

GF6115VS

GF6165

GF6165VS



∅ D ₁ M	P mm	d ₁ mm	l ₁ mm	l ₂ mm	d ₂ mm		
4	0.70	3.00	48	8.8	6	3	3.30
5	0.80	3.80	48	10.8	6	3	4.20
6	1.00	4.50	54	13.5	6	3	5.00
8	1.25	5.95	54	18.1	6	3	6.80
10	1.50	7.95	64	21.8	8	4	8.50
12	1.75	9.95	72	25.4	10	4	10.20
14	2.00	9.95	74	31.0	10	4	12.00
16	2.00	11.95	80	35.0	12	4	14.00
18	2.50	13.95	90	41.3	14	4	15.50
20							17.50

ID

ID

ID

ID

146298

146969

146299

146970

146300

146971

126350

116398

146321

146972

126586

116399

146322

146973

124836

116400

116342

116401

125066

116402

125114

115990

125229

116403

GF

GF6116

GF6116VS

VS
GF6166

GF6166VS

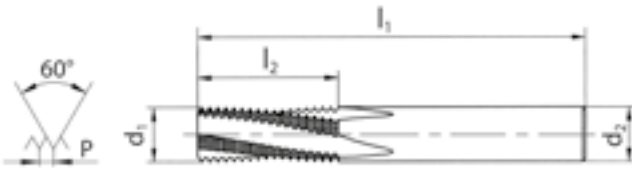
VS

GF6116
GF6116VS
GF6166
GF6166VS

$\varnothing D_1$ M	P mm	d_1 mm	l_1 mm	l_2 mm	d_2 mm		
4	0.70	3.00	48	10.9	6	3	3.30
5	0.80	3.80	48	13.2	6	3	4.20
6	1.00	4.50	54	16.5	6	3	5.00
8	1.25	5.95	54	21.9	6	3	6.80
10	1.50	7.95	64	26.3	8	4	8.50
12	1.75	9.95	74	32.4	10	4	10.20
14	2.00	9.95	74	37.0	10	4	12.00
16	2.00	11.95	90	43.0	12	4	14.00
18	2.50	13.95	105	53.8	14	4	15.50
20							17.50

ID
ID
ID
ID

155365

155370

155366

155371

155367

155372

155375

155382

155368

155373

155376

155383

155369

155374

155377

155384

155378

155385

155379

155386

155380

155387

155381

155388



GF

GF6110



GF6110VS



GF6110

GF6110VS

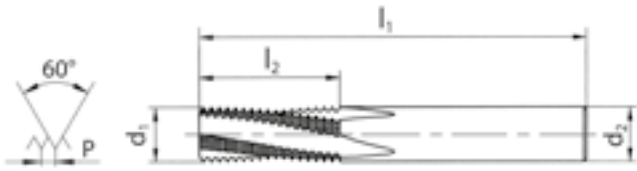

∅ D ₁ MF	P mm	d ₁ mm	l ₁ mm	l ₂ mm	d ₂ mm		
------------------------	---------	----------------------	----------------------	----------------------	----------------------	--	--

4	0.50	3.00	48	7.3	6	3	3.50
5	0.50	3.80	48	8.8	6	3	4.50

ID

ID

135218

135219

135069

135220

GF

GF6165

GF6165VS

GF6166

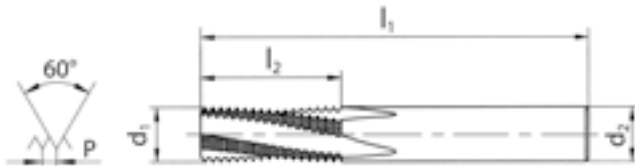
GF6166VS

GF6165
GF6165VS
GF6166
GF6166VS

∅ D ₁ MF	P mm	d ₁ mm	l ₁ mm	l ₂ mm	d ₂ mm		
6	0.50	4.50	54	12.8	6	3	5.50
6	0.75	4.50	54	13.1	6	3	5.25
8	0.50	5.95	54	17.8	6	3	7.50
8	0.75	5.95	54	16.9	6	3	7.25
8	1.00	5.95	54	17.5	6	3	7.00
10	1.00	7.95	64	21.5	8	4	9.00
10	1.25	7.95	64	21.9	8	4	8.80
12	1.00	9.95	72	25.5	10	4	11.00
12	1.50	9.95	72	26.3	10	4	10.50

ID
ID

135221	135222
123664	123665
135002	135223
143110	135224
124239	116404
119986	116405
120102	116406
120303	116407
120392	120393

∅ D ₁ MF	P mm	d ₁ mm	l ₁ mm	l ₂ mm	d ₂ mm		
6	0.50	4.50	54	15.8	6	3	5.50
6	0.75	4.50	54	16.1	6	3	5.25
8	0.50	5.95	54	20.8	6	3	7.50
8	0.75	5.95	54	20.6	6	3	7.25
8	1.00	5.95	54	21.5	6	3	7.00
10	1.00	7.95	64	26.5	8	4	9.00
10	1.25	7.95	64	26.9	8	4	8.80
12	1.00	9.95	74	31.5	10	4	11.00
12	1.50	9.95	74	32.3	10	4	10.50

ID
ID

155389	155398
155390	155399
155391	155400
155392	155401
155393	155402
155394	155403
155395	155404
155396	155405
155397	155406



GF

GF6110



GF6110VS



GF6110

GF6110VS

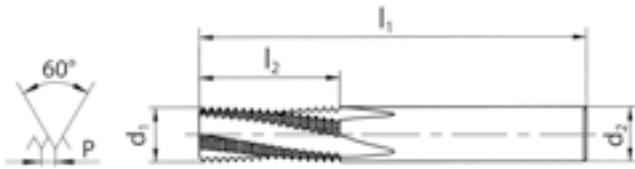

Ø" D ₁ UNC	P TPI	d ₁ mm	l ₁ mm	l ₂ mm	d ₂ mm		
10	24	3.60	48	10.1	6.0	3	3.80
12	24	4.10	48	10.1	6.0	3	4.40
1/4	20	4.80	54	12.1	6.0	3	5.10

ID

ID

135225

135226

135227

135228

135229

135230

GF

GF6165

GF6165VS

GF6166

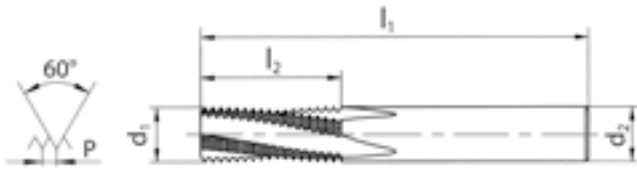
GF6166VS

GF6165
GF6165VS
GF6166
GF6166VS

Ø" D ₁ UNC	P TPI	d ₁ mm	l ₁ mm	l ₂ mm	d ₂ mm		
--------------------------	----------	----------------------	----------------------	----------------------	----------------------	--	--

1/4	20	4.80	54	14.6	6.0	3	5.10
5/16	18	5.95	54	17.6	6.0	3	6.50
3/8	16	7.10	64	21.5	8.0	4	8.00
7/16	14	7.95	64	24.5	8.0	4	9.30
1/2	13	9.95	72	28.4	10.0	4	10.80

ID
ID

155407	155408
116047	135231
135232	135233
116049	135234
135235	135236

Ø" D ₁ UNC	P TPI	d ₁ mm	l ₁ mm	l ₂ mm	d ₂ mm		
--------------------------	----------	----------------------	----------------------	----------------------	----------------------	--	--

1/4	20	4.80	54	17.1	6.0	3	5.10
5/16	18	5.95	54	21.9	6.0	3	6.50
3/8	16	7.10	64	26.2	8.0	4	8.00
7/16	14	7.95	64	29.9	8.0	4	9.30
1/2	13	9.95	74	34.2	10.0	4	10.80

ID
ID

155409	155414
155410	155415
155411	155416
155412	155417
155413	155418

UNF ANSI B1.1

VHM
CAR



DIN 6535 HA

HB
HE

应要求
on request

GF

GF6110



GF6110VS



VS

GF6110

GF6110VS

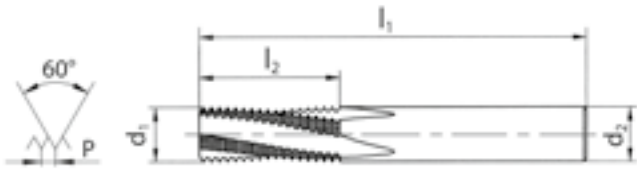

∅" D ₁ UNF	P TPI	d ₁ mm	l ₁ mm	l ₂ mm	d ₂ mm		
10	32	3.60	48	8.3	6.0	3	4.05
12	28	4.10	48	9.5	6.0	3	4.60
1/4	28	4.80	54	11.3	6.0	3	5.50

ID

ID

128659

135237

135238

135239

135240

135176

GF-GFH-GFS

GF

GF6165

GF6165VS

GF6166

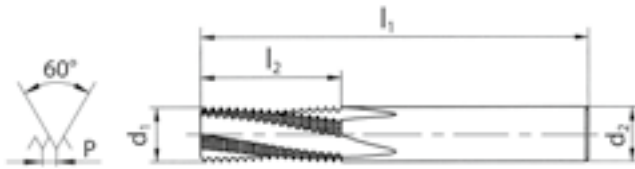
GF6166VS

GF6165
GF6165VS
GF6166
GF6166VS

Ø" D ₁ UNF	P TPI	d ₁ mm	l ₁ mm	l ₂ mm	d ₂ mm			ID	ID
1/4	28	4.80	54	14.1	6.0	3	5.50	155419	155420
5/16	24	5.95	54	17.5	6.0	3	6.90	135242	135243
3/8	24	7.10	64	20.6	8.0	4	8.50	135182	135245
7/16	20	7.95	64	24.8	8.0	4	9.80	135246	135247
1/2	20	9.95	72	27.3	10.0	4	11.40	135183	135249

Ø" D ₁ UNF	P TPI	d ₁ mm	l ₁ mm	l ₂ mm	d ₂ mm			ID	ID
1/4	28	4.80	54	16.8	6.0	3	5.50	155421	155426
5/16	24	5.95	54	20.6	6.0	3	6.90	155422	155427
3/8	24	7.10	64	24.9	8.0	4	8.50	155423	155428
7/16	20	7.95	64	28.6	8.0	4	9.80	155424	155429
1/2	20	9.95	74	33.7	10.0	4	11.40	155425	155430

G DIN ISO 228 (BSP)

VHM
CAR



DIN 6535 HA

HB
HE

应要求
on request

GF

GF6165



GF6165VS



GF6166



GF6166VS



GF6165

GF6165VS

GF6166

GF6166VS

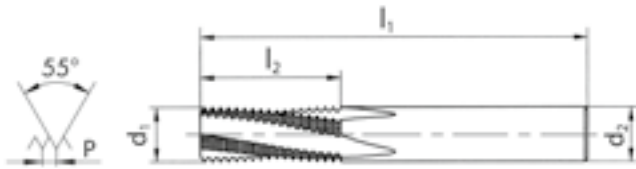
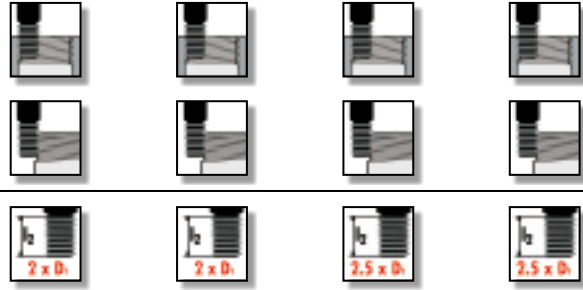

$\varnothing'' D_1$ G	P TPI	d_1 mm	l_1 mm	l_2 mm	d_2 mm		
1/8	28	7.95	64	21.3	8.0	4	8.75
1/4	19	9.95	72	28.7	10.0	4	11.60
3/8	19	13.60	80	35.4	14.0	4	15.20

ID

ID

119347 116409
119292 116410
119678 116411

$\varnothing'' D_1$ G	P TPI	d_1 mm	l_1 mm	l_2 mm	d_2 mm		
1/8	28	7.95	64	24.9	8.0	4	8.75
1/4	19	9.95	74	34.1	10.0	4	11.60
3/8	19	13.60	90	43.4	14.0	4	15.20

ID

ID

155431 155434
155432 155435
155433 155436

GF-GFH-GFS



GF

GF6160



GF6160VS



GF6160

GF6160VS

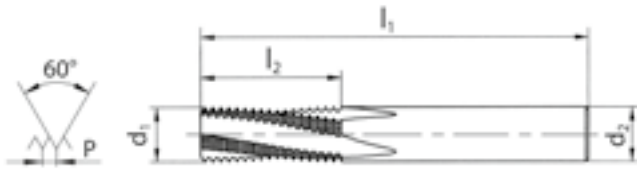

Ø" D ₁ NPT	P TPI	d ₁ mm	l ₁ mm	l ₂ mm	d ₂ mm	✚
1/8	27	7.30	64	9.9	8.0	4
1/4	18	9.95	72	14.8	12.0	4
3/8	18	12.50	80	14.8	14.0	4
1/2	14	14.70	90	19.1	16.0	4

ID

ID

116371	116435
135250	135251
135252	135253
155437	155438

Ø" D ₁ NPTF	P TPI	d ₁ mm	l ₁ mm	l ₂ mm	d ₂ mm	✚
1/8	27	7.30	64	9.9	8.0	4
1/4	18	9.95	72	14.8	12.0	4
3/8	18	12.50	80	14.8	14.0	4
1/2	14	14.70	90	19.1	16.0	4

ID

ID

* 135254	
* 135256	* 135257
* 135258	* 135259
* 155439	* 155440

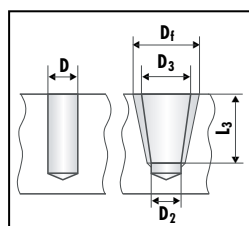

Ø D ₁	底孔 Core hole			
	D	D ₂	NPT NPTF D ₃ (+0.05)	
1/8	8.5	8.3	8.74	8.76
1/4	11.0	10.8	11.36	11.40
3/8	14.5	14.2	14.80	14.84
1/2	17.9	17.5	18.32	18.33

铣削 Milling	
D _f	L ₃
9.81	6.92
12.99	10.02
16.41	10.33
20.37	13.57

GFS

GFS6610

GFS6610VS

GFS6660

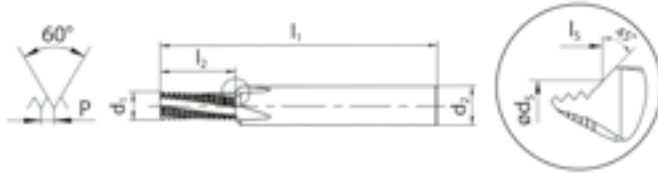
GFS6660VS

GFS6610

GFS6610VS

GFS6660

GFS6660VS

Ø D ₁ M	P mm	d ₁ mm	l ₁ mm	l ₂ mm	l ₃ mm	d _s mm	d ₂ mm		
-----------------------	---------	----------------------	----------------------	----------------------	----------------------	----------------------	----------------------	--	--

2	0.40	1.50	48	3.4	3.7	2.1	6	2	1.60
2.5	0.45	1.90	48	4.3	4.7	2.6	6	3	2.05
3	0.50	2.30	48	5.3	5.6	3.1	6	3	2.50
3.5	0.60	2.70	48	5.7	6.2	3.6	6	3	2.90
4	0.70	3.00	48	7.3	7.9	4.1	6	3	3.30
5	0.80	3.80	54	9.2	9.9	5.1	6	3	4.20
6	1.00	4.50	62	10.5	11.3	6.2	8	3	5.00
8	1.25	5.95	74	13.1	14.3	8.2	10	3	6.80
10	1.50	7.95	80	17.3	18.4	10.3	12	4	8.50
12	1.75	9.95	90	20.1	21.3	12.3	14	4	10.20
14	2.00	10.80	102	25.0	26.8	14.4	16	4	12.00
16	2.00	12.80	102	27.0	28.8	16.4	18	4	14.00
18	2.50	13.95	125	33.8	36.0	18.5	25	4	15.50
20					37.0	20.5			17.50

ID
ID
ID
ID

* 135331	* 135332		
* 155441	* 155443		
135333	135334		
* 155442	* 155444		
135335	135336		
135337	135338		
135339	116175		
		135340	116172
		135341	116173
		135342	116174
		* 135343	* 135344
		135345	135346
		* 135347	* 135348

GFS

GFS6615

GFS6615VS

GFS6665

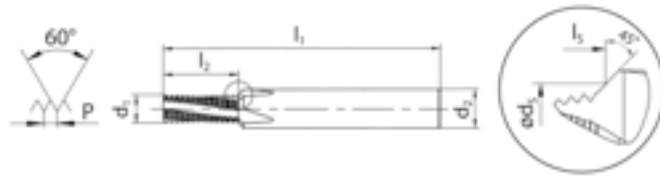
GFS6665VS

GFS6615
GFS6615VS
GFS6665
GFS6665VS

Ø D ₁ M	P mm	d ₁ mm	l ₁ mm	l ₂ mm	l ₃ mm	d _s mm	d ₂ mm		
2	0.40	1.50	48	4.6	4.9	2.1	6	2	1.60
2.5	0.45	1.90	48	5.6	6.0	2.6	6	3	2.05
3	0.50	2.30	48	6.8	7.1	3.1	6	3	2.50
3.5	0.60	2.70	48	7.5	8.0	3.6	6	3	2.90
4	0.70	3.00	48	8.8	9.3	4.1	6	3	3.30
5	0.80	3.80	54	10.8	11.5	5.1	6	3	4.20
6	1.00	4.50	62	13.5	14.3	6.2	8	3	5.00
8	1.25	5.95	74	18.1	19.3	8.2	10	3	6.80
10	1.50	7.95	80	21.8	22.9	10.3	12	4	8.50
12	1.75	9.95	90	25.4	26.6	12.3	14	4	10.20
14	2.00	10.80	102	31.0	32.8	14.4	16	4	12.00
16	2.00	12.80	102	35.0	36.8	16.4	18	4	14.00
18	2.50	13.95	125	41.3	43.5	18.5	25	4	15.50
20					44.5	20.5			17.50

ID
ID
ID
ID

135349

135350

155445

155447

125661

135351

* 155446

* 147108

125946

135352

126160

116178

126352

135353

155524

155525

126587

116343

124837

135354

124973

135355

* 125067

* 135356

125116

135357

* 125231

* 135358

GFS

GFS6616

GFS6616VS

GFS6666

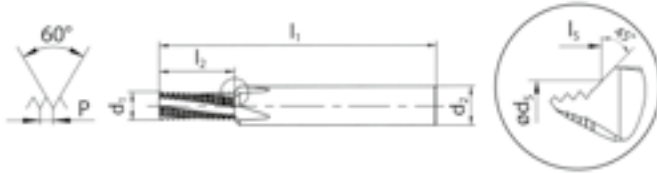
GFS6666VS

GFS6616
GFS6616VS
GFS6666
GFS6666VS

Ø D ₁ M	P mm	d ₁ mm	l ₁ mm	l ₂ mm	l ₃ mm	d _s mm	d ₂ mm		
-----------------------	---------	----------------------	----------------------	----------------------	----------------------	----------------------	----------------------	--	--

3	0.50	2.30	48	8.3	8.7	3.1	6	3	2.50
4	0.70	3.00	48	10.9	11.5	4.1	6	3	3.30
5	0.80	3.80	54	13.2	13.9	5.1	6	3	4.20
6	1.00	4.50	62	16.5	17.4	6.2	8	3	5.00
8	1.25	5.95	74	21.9	23.0	8.2	10	3	6.80
10	1.50	7.95	80	26.3	27.5	10.3	12	4	8.50
12	1.75	9.95	90	32.4	33.6	12.3	14	4	10.20
14	2.00	10.80	102	37.0	38.8	14.4	16	4	12.00
16	2.00	12.80	102	43.0	44.8	16.4	18	4	14.00
18	2.50	13.95	125	53.8	56.1	18.5	25	4	15.50
20					57.1	20.5			17.50

ID
ID
ID
ID
155448
155452
155449
155453
155450
155454
155451
155455
155456
155463
155457
155464
155458
155465
155459
155466
*** 155460**
*** 155467**
155461
155468
*** 155462**
*** 155469**

GFS

GFS6610

GFS6610VS

GFS6660

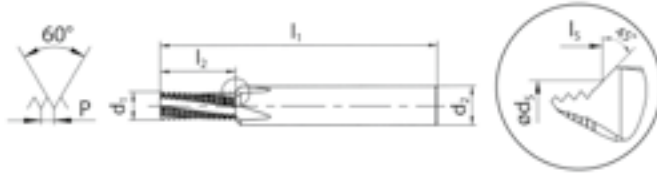
GFS6660VS

GFS6610
GFS6610VS
GFS6660
GFS6660VS

$\varnothing D_1$ MF	P mm	d_1 mm	l_1 mm	l_2 mm	l_3 mm	d_s mm	d_2 mm			ID	ID	ID	ID
4	0.50	3.00	48	7.3	7.8	4.1	6	3	3.50	135359	135360		
5	0.50	3.80	54	8.8	9.4	5.1	6	3	4.50	135361	135362		
6	0.50	4.50	62	9.8	10.6	6.2	8	3	5.50	135363	135364		
6	0.75	4.50	62	10.1	11.0	6.2	8	3	5.25	135365	135366		
8	0.50	5.95	74	12.8	13.9	8.2	10	3	7.50			135367	135368
8	0.75	5.95	74	13.1	14.3	8.2	10	3	7.25			135369	135370
8	1.00	5.95	74	13.5	14.6	8.2	10	3	7.00			135371	135372
10	1.00	7.95	80	16.5	17.7	10.3	12	4	9.00			135373	135374
10	1.25	7.95	80	16.9	18.1	10.3	12	4	8.80			* 135375	* 135376
12	1.00	9.95	90	19.5	20.7	12.3	14	4	11.00			135377	135378
12	1.50	9.95	90	20.3	21.4	12.3	14	4	10.50			135379	135380
14	1.50	10.80	102	23.3	25.0	14.4	16	4	12.50			135381	135382
16	1.50	12.80	102	26.3	28.1	16.4	18	4	14.50			135383	135384

GFS

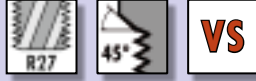
GFS6615

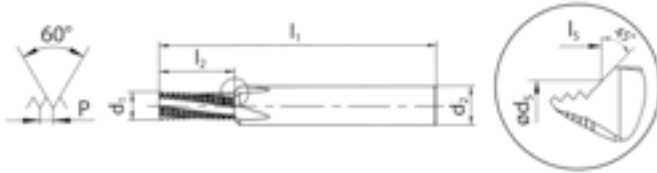
GFS6615VS

GFS6665

GFS6665VS

GFS6615
GFS6615VS
GFS6665
GFS6665VS

∅ D ₁ MF	P mm	d ₁ mm	l ₁ mm	l ₂ mm	l ₃ mm	d _s mm	d ₂ mm		
------------------------	---------	----------------------	----------------------	----------------------	----------------------	----------------------	----------------------	--	--

4	0.50	3.00	48	8.8	9.3	4.1	6	3	3.50
5	0.50	3.80	54	10.8	11.4	5.1	6	3	4.50
6	0.50	4.50	62	12.8	13.6	6.2	8	3	5.50
6	0.75	4.50	62	13.1	14.0	6.2	8	3	5.25
8	0.50	5.95	74	17.8	18.9	8.2	10	3	7.50
8	0.75	5.95	74	16.9	18.0	8.2	10	3	7.25
8	1.00	5.95	74	17.5	18.6	8.2	10	3	7.00
10	1.00	7.95	80	21.5	22.7	10.3	12	4	9.00
10	1.25	7.95	80	21.9	23.0	10.3	12	4	8.80
12	1.00	9.95	90	25.5	26.7	12.3	14	4	11.00
12	1.50	9.95	90	26.3	27.4	12.3	14	4	10.50
14	1.50	10.80	102	30.8	32.5	14.4	16	4	12.50
16	1.50	12.80	102	33.8	35.6	16.4	18	4	14.50

ID
ID
ID
ID
135385
135386
135387
135388
135389
135390
135391
135392
135393
135394
135395
135396
135397
135398
135399
135400
135401
135402
135403
135404
135405
135406
135407
135408
135409
135410

GFS

GFS

GFS6610

GFS6610VS

GFS6660

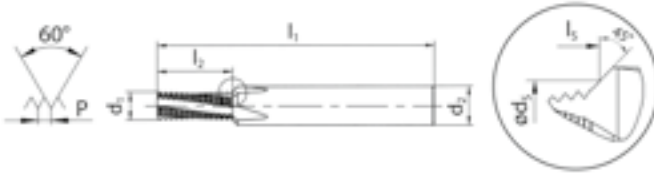
GFS6660VS

GFS6610
GFS6610VS
GFS6660
GFS6660VS

Ø" D ₁ UNC	P TPI	d ₁ mm	l ₁ mm	l ₂ mm	l ₃ mm	d ₃ mm	d ₂ mm		
10	24	3.60	54	10.1	10.7	4.9	6	3	3.80
12	24	4.10	54	10.1	10.8	5.6	6	3	4.40
1/4	20	4.80	62	12.1	12.9	6.5	8	3	5.10
5/16	18	5.95	74	14.8	15.9	8.1	10	3	6.50
3/8	16	7.10	80	16.7	18.0	9.8	12	4	8.00
7/16	14	7.95	80	19.0	20.8	11.4	12	4	9.30
1/2	13	9.95	90	22.5	24.0	13.0	14	4	10.80
9/16	12	10.80	102	24.4	26.3	14.6	16	4	12.20
5/8	11	11.90	102	26.5	28.8	16.3	18	4	13.60

ID
ID
ID
ID

* 135420

* 135421

* 135422

* 135423

* 135424

* 135425

* 155470

* 155473

* 135426

* 135427

* 155471

* 155474

* 135428

* 135429

* 155472

* 155475

* 135430

* 135431

* 135432

* 135433

* 135434

* 135435

* 135436

* 135437

GFS

GFS6615

GFS6615VS

GFS6665

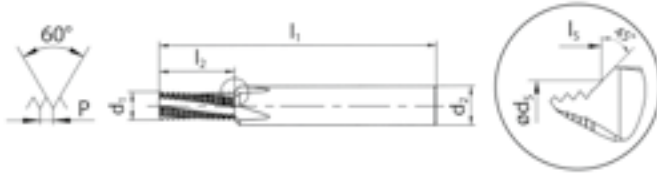
GFS6665VS

GFS6615
GFS6615VS
GFS6665
GFS6665VS

∅" D ₁	P	d ₁	l ₁	l ₂	l ₃	d _s	d ₂		
UNC	TPI	mm	mm	mm	mm	mm	mm		

10	24	3.60	54	12.2	12.8	4.9	6	3	3.80
12	24	4.10	54	13.2	14.0	5.6	6	3	4.40
1/4	20	4.80	62	14.6	15.5	6.5	8	3	5.10
5/16	18	5.95	74	17.6	18.7	8.1	10	3	6.50
3/8	16	7.10	80	21.5	22.8	9.8	12	4	8.00
7/16	14	7.95	80	24.5	26.2	11.4	12	4	9.30
1/2	13	9.95	90	28.4	29.9	13.0	14	4	10.80
9/16	12	10.80	102	32.8	34.7	14.6	16	4	12.20
5/8	11	11.90	102	35.8	38.0	16.3	18	4	13.60

ID
ID
ID
ID

* 135438

* 135439

* 135440

* 135441

* 135442

* 135443

* 155476

* 155479

* 135444

* 135445

* 155477

* 155480

* 135446

* 135447

* 155478

* 155481

* 135448

* 135449

* 135450

* 135451

* 135452

* 135453

* 135454

* 135455

GFS

GFS6610

GFS6610VS

GFS6660

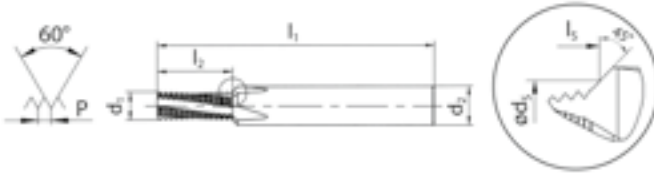
GFS6660VS

GFS6610
GFS6610VS
GFS6660
GFS6660VS

Ø" D ₁	P	d ₁	l ₁	l ₂	l _s	d _s	d ₂		
UNF	TPI	mm	mm	mm	mm	mm	mm		

10	32	3.60	54	8.3	9.0	4.9	6	3	4.05
12	28	4.10	54	9.5	10.3	5.6	6	3	4.60
1/4	28	4.80	62	11.3	12.2	6.5	8	3	5.50
5/16	24	5.95	74	13.2	14.3	8.1	10	3	6.90
3/8	24	7.10	80	16.4	17.3	9.8	12	4	8.50
7/16	20	7.95	80	18.4	20.1	11.4	12	4	9.80
1/2	20	9.95	90	21.0	22.5	13.0	14	4	11.40
9/16	18	11.60	102	23.3	24.8	14.6	16	4	12.90
5/8	18	11.90	102	26.1	28.3	16.3	18	4	14.50

ID
ID
ID
ID

* 135456

* 135457

* 135458

* 135459

* 135460

* 135461

* 155482

* 155485

* 135462

* 135463

* 155483

* 155486

* 135464

* 135465

* 155484

* 155487

* 135466

* 135467

* 135468

* 135469

* 135470

* 135471

* 135472

* 135473

GFS

GFS6615



GFS6615VS



GFS6665



GFS6665VS

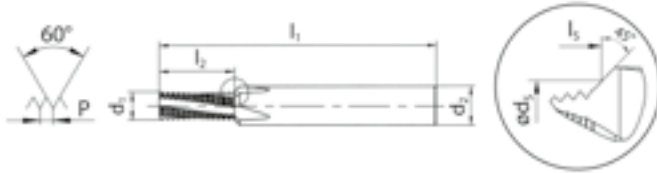

GFS6615



GFS6615VS



GFS6665



GFS6665VS



Ø" D ₁	P	d ₁	l ₁	l ₂	l ₃	d _s	d ₂		
UNF	TPI	mm	mm	mm	mm	mm	mm		

10	32	3.60	54	11.5	12.2	4.9	6	3	4.05
12	28	4.10	54	12.3	13.0	5.6	6	3	4.60
1/4	28	4.80	62	14.1	14.9	6.5	8	3	5.50
5/16	24	5.95	74	17.5	18.6	8.1	10	3	6.90
3/8	24	7.10	80	20.6	21.5	9.8	12	4	8.50
7/16	20	7.95	80	24.8	26.5	11.4	12	4	9.80
1/2	20	9.95	90	27.3	28.8	13.0	14	4	11.40
9/16	18	11.60	102	30.4	31.9	14.6	16	4	12.90
5/8	18	11.90	102	34.6	36.8	16.3	18	4	14.50

ID

ID

ID

ID

128660

135474

* 135475

* 135476

128578

135477

155488

155491

135478

135479

155489

155492

135480

135481

155490

155493

* 135482

* 135483

* 135484

* 135485

* 135486

* 135487

* 135488

* 135489

GFS

GFS6660

GFS6660VS

GFS6665

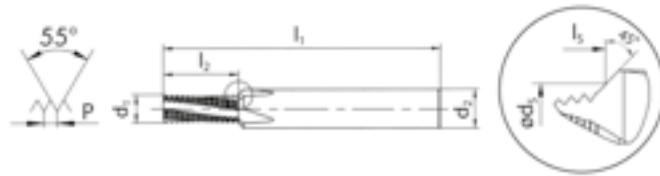
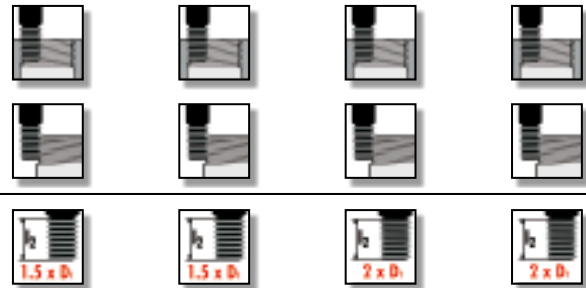
GFS6665VS

GFS6660
GFS6660VS
GFS6665
GFS6665VS

$\varnothing'' D_1$ G	P TPI	d_1 mm	l_1 mm	l_2 mm	l_3 mm	d_s mm	d_2 mm		
1/8	28	7.95	80	15.9	16.9	10.0	12	4	8.75
1/4	19	9.95	90	22.1	23.8	13.5	14	4	11.60
3/8	19	12.80	102	27.4	29.5	17.1	18	4	15.20

ID
ID

* 135411	* 135412
* 135413	* 135414
* 135415	* 135416

$\varnothing'' D_1$ G	P TPI	d_1 mm	l_1 mm	l_2 mm	l_3 mm	d_s mm	d_2 mm		
1/8	28	7.95	80	21.3	22.3	10.0	12	4	8.75
1/4	19	9.95	90	28.7	30.5	13.5	14	4	11.60
3/8	19	12.80	102	35.4	37.6	17.1	18	4	15.20

ID
ID

* 119349	* 135417
* 119298	* 135418
* 119680	* 135419

GFS

GFS6660



GFS6660VS



GFS6660

GFS6660VS

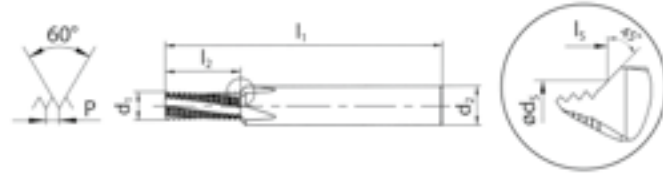

Ø" D ₁ NPT	P TPI	d ₁ mm	l ₁ mm	l ₂ mm	l ₃ mm	d _s mm	d ₂ mm	
--------------------------	----------	----------------------	----------------------	----------------------	----------------------	----------------------	----------------------	--

1/8	27	7.30	70	9.9	11.2	10.6	12	4
1/4	18	9.95	80	14.8	16.4	14.0	16	4
3/8	18	12.50	80	14.8	16.9	17.6	18	4

ID

ID

* 126910	* 135490
* 126899	* 135491
* 126928	* 135492

Ø" D ₁ NPTF	P TPI	d ₁ mm	l ₁ mm	l ₂ mm	l ₃ mm	d _s mm	d ₂ mm	
---------------------------	----------	----------------------	----------------------	----------------------	----------------------	----------------------	----------------------	--

1/8	27	7.30	70	9.9	11.2	10.6	12	4
1/4	18	9.95	80	14.8	16.4	14.0	16	4
3/8	18	12.50	80	14.8	16.9	17.6	18	4

ID

ID

* 135493	* 135494
* 135495	* 135496
* 135497	* 135498

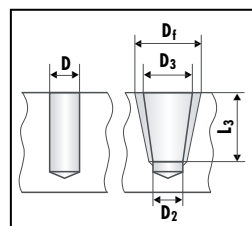

Ø D ₁	底孔 Core hole			
	D	D ₂	NPT NPTF D ₃ (+0.05)	
1/8	8.5	8.3	8.74	8.76
1/4	11.0	10.8	11.36	11.40
3/8	14.5	14.2	14.80	14.84

铣削 Milling	
D _f	L ₃
9.81	6.92
12.99	10.02
16.41	10.33

GFM

GFM6260

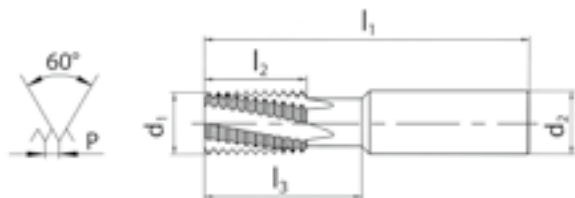
GFM6260VS

GFM6260
GFM6260VS

d_1 mm	P mm	$\varnothing D_1$ $\geq M, MF$	l_1 mm	l_2 mm	l_3 mm	d_2 mm		ID	ID
8	0.50	10	64	16.0	16	8.0	4	116450	135260
8	0.75	10	64	15.8	16	8.0	4	116340	135261
10	0.75	14	70	15.8	26	10.0	4	116128	135262
10	1.00	14	70	16.0	26	10.0	4	118657	135263
10	1.25	14	70	16.3	26	10.0	4	118659	135264
10	1.50	14	70	16.5	26	10.0	4	118661	135265
12	0.50	18	80	20.0	32	12.0	4	116129	135214
12	0.75	18	80	20.3	32	12.0	4	155526	155527
12	1.00	18	80	20.0	32	12.0	4	118664	135007
12	1.50	18	80	21.0	32	12.0	4	118669	135181
12	2.00	18	80	20.0	32	12.0	4	118673	135269
16	1.00	24	90	25.0	42	16.0	4	118680	135270
16	1.50	24	90	25.5	42	16.0	4	118682	116017
16	2.00	24	90	26.0	42	16.0	4	118684	135271
16	2.50	24	90	25.0	42	16.0	4	118689	135272
16	3.00	24	90	27.0	42	16.0	4	158760	150564
20	1.00	30	105	33.0	52	20.0	5	135273	135274
20	1.50	30	105	33.0	52	20.0	5	118694	135275
20	2.00	30	105	34.0	52	20.0	5	116338	135276
20	2.50	30	105	32.5	52	20.0	5	* 135277	
20	3.00	30	105	33.0	52	20.0	5	118699	135279
20	3.50	30	105	38.5	52	20.0	5	144195	144065

GFM

GFM6260

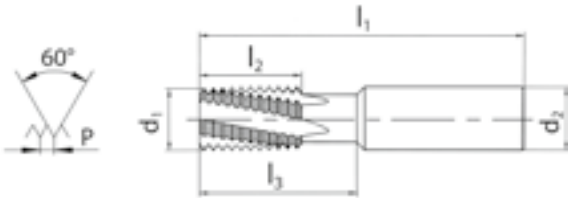
GFM6260VS

GFM6260
GFM6260VS

d ₁ mm	P TPI	Ø" D ₁ ≥ UN	l ₁ mm	l ₂ mm	l ₃ mm	d ₂ mm		ID	ID
10	24	1/2	70	15.9	26	10	4	135288	135289
12	24	3/4	80	20.1	32	12	4	135290	135291
12	20	3/4	80	20.3	32	12	4	135292	135293
12	18	3/4	80	19.8	32	12	4	135294	135295
12	16	3/4	80	20.6	32	12	4	135296	135297
12	10	3/4	80	20.3	32	12	4	150963	155494
16	24	1	90	25.4	42	16	4	135298	135299
16	20	1	90	25.4	42	16	4	135300	135301
16	18	1	90	25.4	42	16	4	135302	135303
16	16	1	90	25.4	42	16	4	135304	135305
16	14	1	90	25.4	42	16	4	135306	135307
16	12	1	90	25.4	42	16	4	135308	135309
16	9	1	90	25.4	42	16	4	150964	155495
16	8	1	90	25.4	42	16	4	150965	155496
20	24	1 1/4	105	32.8	52	20	5	* 135310	* 135311
20	20	1 1/4	105	33.0	52	20	5	* 135312	* 135313
20	18	1 1/4	105	32.5	52	20	5	135314	135315
20	16	1 1/4	105	33.4	52	20	5	118697	135316
20	14	1 1/4	105	32.7	52	20	5	135317	135318
20	12	1 1/4	105	31.8	52	20	5	135319	135320
20	8	1 1/4	105	31.8	52	20	5	135321	135322
20	7	1 1/4	105	32.7	52	20	5	150962	155497

GFM

GFM6260

GFM6260VS

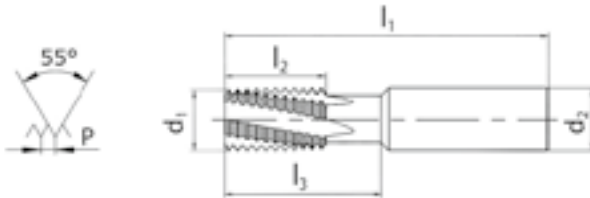
GFM6260
GFM6260VS

d ₁ mm	P TPI	Ø" D ₁ G	l ₁ mm	l ₂ mm	l ₃ mm	d ₂ mm	✂
10	19	1/4 - 3/8	70	16.0	26	10	4
16	14	1/2 - 7/8	90	25.4	42	16	4
20	11	≥ 1	105	32.3	52	20	5

ID
ID

118655

135280

118678

135281

118691

135282

NPT, NPTF

ANSI B1.20.1
ANSI B1.20.3

VHM
CAR



DIN 6535 HA

HB
HE

应要求
on request

GFM

GFM6260



GFM6260VS

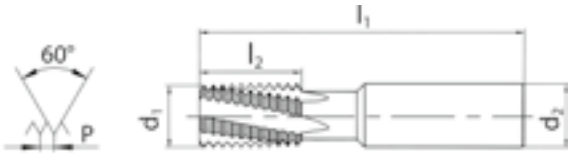

GFM6260 GFM6260VS



d ₁ mm	P TPI	∅" D ₁ ≥ NPT	l ₁ mm	l ₂ mm	d ₂ mm	牙数
----------------------	----------	----------------------------	----------------------	----------------------	----------------------	----

14.5	14	1/2	90	19.1	16	4
18.5	11.5	1	90	23.2	20	5

ID ID

135323	135324
135325	135326

d ₁ mm	P TPI	∅" D ₁ ≥ NPTF	l ₁ mm	l ₂ mm	d ₂ mm	牙数
----------------------	----------	-----------------------------	----------------------	----------------------	----------------------	----

14.5	14	1/2	90	19.1	16	4
18.5	11.5	1	90	23.2	20	5

ID ID

* 135327	* 135328
* 135329	* 135330

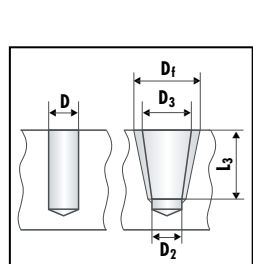

∅ D ₁	底孔 Core hole			
	D	D ₂	NPT D ₃ (+0.05)	NPTF D ₃ (+0.05)
1/2	17.9	17.5	18.32	18.33
3/4	23.2	22.8	23.67	23.68
1	29.0	28.6	29.69	29.72
1 1/4	37.7	37.3	38.45	38.48
1 1/2	44.0	43.5	44.52	44.55
2	56.0	55.5	56.56	56.59

铣削 Milling	
D _f	L ₃
20.37	13.57
25.69	14.05
32.18	16.79
40.90	17.30
49.67	17.30
58.99	17.70

BGF

BGF6760

BGF6760VS

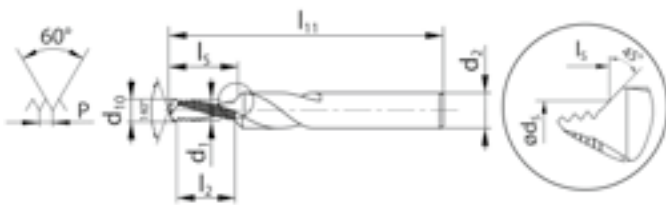
BGF6760
BGF6760VS

$\varnothing D_1$ M	P mm	d_1 mm	d_{10} mm	l_{11} mm	l_2 mm	l_3 mm	d_5 mm	d_2 mm		ID	ID
4	0.70	3.10	3.30	48	5.6	7.4	4.1	6	2	153400	153415
5	0.80	4.00	4.20	54	7.2	9.4	5.1	6	2	153401	153416
6	1.00	4.75	5.00	62	9.0	11.7	6.2	8	2	153402	153417
8	1.25	6.50	6.75	74	11.2	14.6	8.2	10	2	151911	153418
10	1.50	8.25	8.50	80	14.9	19.1	10.3	12	2	153403	151442
12	1.75	9.95	10.25	90	17.4	22.1	12.3	14	2	153404	153419
14	2.00	11.60	12.00	102	19.9	25.1	14.4	16	2	* 153405	* 153420
16	2.00	13.60	14.00	102	23.9	29.5	16.4	18	2	* 153406	* 153421

BGF

BGF6765

BGF6765VS

BGF6766

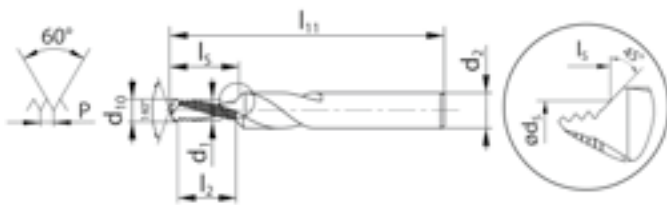
BGF6766VS

BGF6765
BGF6765VS
BGF6766
BGF6766VS

$\varnothing D_1$ M	P mm	d_1 mm	d_{10} mm	l_{11} mm	l_2 mm	l_s mm	d_s mm	d_2 mm	
4	0.70	3.10	3.30	48	7.7	9.5	4.1	6	2
5	0.80	4.00	4.20	54	9.6	11.8	5.1	6	2
6	1.00	4.75	5.00	62	12.0	14.7	6.2	8	2
8	1.25	6.50	6.75	74	15.0	18.4	8.2	10	2
10	1.50	8.25	8.50	80	19.4	23.6	10.3	12	2
12	1.75	9.95	10.25	90	22.7	27.3	12.3	14	2
14	2.00	11.60	12.00	102	27.9	33.1	14.4	16	2
16	2.00	13.60	14.00	102	31.9	37.5	16.4	18	2

ID
ID

153430	153442
151305	151306
150933	151776
153431	150588
153432	150589
153433	150927
* 153434	* 153443
* 153435	* 151324

$\varnothing D_1$ M	P mm	d_1 mm	d_{10} mm	l_{11} mm	l_2 mm	l_s mm	d_s mm	d_2 mm	
6	1.00	4.75	5.00	62	15.0	17.7	6.2	8	2
8	1.25	6.50	6.75	74	20.0	23.4	8.2	10	2
10	1.50	8.25	8.50	80	23.9	28.1	10.3	12	2
12	1.75	9.95	10.25	90	29.7	34.3	12.3	14	2
14	2.00	11.60	12.00	102	35.9	41.1	14.4	16	2
16	2.00	13.60	14.00	102	39.9	45.5	16.4	18	2

ID
ID

153451	153467
153452	153468
153453	153469
153454	153470
* 153455	* 153471
* 153456	* 153472

BGF

BGF6865

BGF6865VS

BGF6866

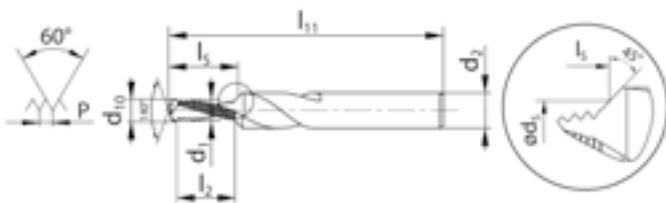
BGF6866VS

BGF6865
BGF6865VS
BGF6866
BGF6866VS

$\varnothing D_1$ M	P mm	d_1 mm	d_{10} mm	l_{11} mm	l_2 mm	l_3 mm	d_5 mm	d_2 mm	
------------------------	---------	-------------	----------------	----------------	-------------	-------------	-------------	-------------	--

6	1.00	4.75	5.00	62	12.0	14.7	6.2	8	3
8	1.25	6.50	6.75	74	14.9	18.4	8.2	10	3
10	1.50	8.25	8.50	80	19.4	23.6	10.3	12	3
12	1.75	9.95	10.25	90	22.7	27.3	12.3	14	3
14	2.00	11.60	12.00	102	27.9	33.1	14.4	16	3
16	2.00	13.60	14.00	102	31.9	37.5	16.4	18	3

ID
ID

* 153577

* 153589

* 153578

* 153590

* 153579

* 153591

* 153580

* 153592

* 153581

* 153593

* 153582

* 153594

$\varnothing D_1$ M	P mm	d_1 mm	d_{10} mm	l_{11} mm	l_2 mm	l_3 mm	d_5 mm	d_2 mm	
------------------------	---------	-------------	----------------	----------------	-------------	-------------	-------------	-------------	--

6	1.00	4.75	5.00	62	15.0	17.7	6.2	8	3
8	1.25	6.50	6.75	74	20.0	23.4	8.2	10	3
10	1.50	8.25	8.50	80	23.9	28.1	10.3	12	3
12	1.75	9.95	10.25	90	29.7	34.3	12.3	14	3
14	2.00	11.60	12.00	102	35.9	41.1	14.4	16	3
16	2.00	13.60	14.00	102	39.9	45.5	16.4	18	3

ID
ID

* 153601

* 153613

* 153602

* 153614

* 153603

* 153615

* 153604

* 153616

* 153605

* 153617

* 153606

* 153618

BGF

BGF6760

BGF6760VS

BGF6765

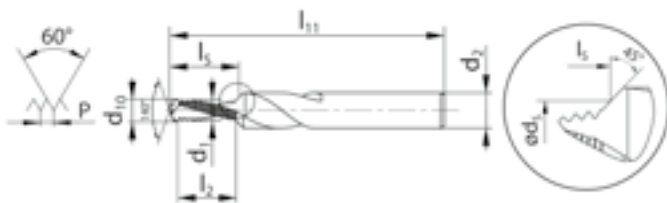
BGF6765VS

BGF6760

BGF6760VS

BGF6765

BGF6765VS

∅ D ₁ MF	P mm	d ₁ mm	d ₁₀ mm	l ₁₁ mm	l ₂ mm	l _s mm	d _s mm	d ₂ mm	z
6	0.75	5.00	5.25	62	9.0	11.4	6.2	8	2
8	1.00	6.75	7.00	74	12.0	15.0	8.2	10	2
10	1.00	8.75	9.00	80	15.0	18.5	10.3	12	2
12	1.00	10.70	11.00	90	18.0	21.9	12.3	14	2
12	1.50	10.20	10.50	90	17.9	22.5	12.3	14	2
14	1.50	12.10	12.50	102	20.9	26.0	14.4	16	2
16	1.50	14.10	14.50	102	23.9	29.4	16.4	18	2

ID	ID
* 153759	* 153780
* 153761	* 153782
* 153762	* 153783
* 153764	* 153785
* 153765	* 153786
* 153766	* 153787
* 153767	* 153788































∅ D ₁ MF	P mm	d ₁ mm	d ₁₀ mm	l ₁₁ mm	l ₂ mm	l _s mm	d _s mm	d ₂ mm	z
6	0.75	5.00	5.25	62	9.0	11.4	6.2	8	2
8	1.00	6.75	7.00	74	12.0	15.0	8.2	10	2
10	1.00	8.75	9.00	80	15.0	18.5	10.3	12	2
12	1.00	10.70	11.00	90	18.0	21.9	12.3	14	2
12	1.50	10.20	10.50	90	17.9	22.5	12.3	14	2
14	1.50	12.10	12.50	102	20.9	26.0	14.4	16	2
16	1.50	14.10	14.50	102	23.9	29.4	16.4	18	2







ID	ID
* 153802	* 153824
* 153804	* 153826
* 153805	* 153827
* 153807	* 153829
* 153808	* 153830
* 153809	* 153831
* 153810	* 153832

BGF









目录 - 圆板牙, 瑞士自动车床专用板牙, 六角板牙, 橡子板牙









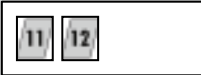

Directory - Round dies, button dies for Swiss automatics, hexagon die nuts and bell form dies

		N		MS	Z		N	Z
特点 Characteristics								
								
								
								
								
		N5110	N5120	MS5120	Z5120	Z5120LL	N5220	Z5220
M 6g	DIN 13	246	246		247	247	260	260
M 6e	DIN 13		246				260	
M 6g LH	DIN 13		246					
MF 6g	DIN 13	248	248-250		248-249		261	
MF 6e	DIN 13		248-249					
MF 6g LH	DIN 13		248-250					
UNC	ANSI B1.1	251	251					
UNF	ANSI B1.1	252	252					
UNEF	ANSI B1.1		253					
UN	ANSI B1.1		253					
UNS	ANSI B1.1		253					
G (BSP)	DIN ISO 228		254	255	255			
G (BSP) LH	DIN ISO 228		254					
G (BSP) -0.1 mm	DIN ISO 228			255				
R (BSPT)	DIN EN 10226		256					
NPT	ANSI B1.20.1		257					
NPTF	ANSI B1.20.3		257					
PG	DIN 40430		258					
TR	DIN 103		258					
W (BSW)	BS 84		259					
W (BSW) LH	BS 84		259					

N	
 	  
	
N5310	N5420
262	263
262	
263	
263	

图标说明 - Pictographs

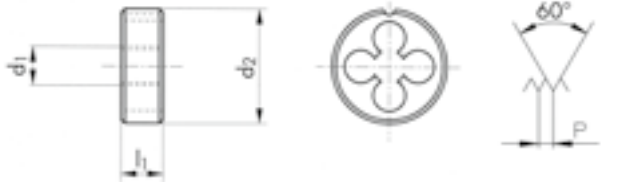
-  高速钢
HSS
-  含钴高速钢
HSSE
-  1.25 螺距倒角
1.25 chamfered threads
-  1.75 螺距倒角
1.75 chamfered threads
-  2 螺距倒角
2 chamfered threads
-  Ø 3 毫米起切割口
Peeling cut from Ø 3 mm
-  Ø 3 毫米起双面切割口
Peeling cut on both sides from Ø 3 mm
-  槽数目
Number of flutes
-  车削直径
Turned diameters
-  氮化处理 ($d_1 \geq 3 \text{ mm}$, $P \geq 0.5 \text{ mm}$)
Nitrided ($d_1 \geq 3 \text{ mm}$, $P \geq 0.5 \text{ mm}$)
-  带两个固定孔
Die with 2 securing holes
-  公差 6g
Tolerance 6g
-  公差 6e
Tolerance 6e
-  公差“中等级”
Tolerance “Medium Class”
-  公差 A
Tolerance A
-  锥度螺纹 1:16 (NPT - NPTF - Rc)
Tapered thread 1:16 (NPT - NPTF - R)
-  左旋螺纹
Left hand thread

								N5110	N5120	N5120 LH	N5120
<p>N5110 </p> <p>N5120  </p> <p>N5120 LH  LH </p> <p>N5120  </p>											
											
											
$\varnothing d_1$ M	P mm	d_2 mm	l_1 mm	\oplus 6g	\oplus LH / 6e	\rightarrow 6g \leftarrow	\rightarrow 6e \leftarrow	ID	ID	ID	ID 6g - mm
1	0.25	16.0	5.0	3		0.97		103851			
1.1	0.25	16.0	5.0	3		1.07		124659			
1.2	0.25	16.0	5.0	3		1.17		103852			
1.4	0.30	16.0	5.0	3		1.36		103853			
1.6	0.35	16.0	5.0	3		1.54		103855			
1.7	0.35	16.0	5.0	3		1.64		103856			
1.8	0.35	16.0	5.0	3		1.74		103857			
2	0.40	16.0	5.0	3		1.93	1.90	103864			
2.2	0.45	16.0	5.0	3		2.13		103867			
2.3	0.40	16.0	5.0	3		2.23		103869			
2.5	0.45	16.0	5.0	3		2.43	2.40	103872			
2.6	0.45	16.0	5.0	3		2.53		103876			
3	0.50	20.0	5.0	3	4	2.92	2.90	103879	104067	104068	104066 0.030
3.5	0.60	20.0	5.0	3	4	3.41	3.38	103880	104071	104072	* 104070 0.030
4	0.70	20.0	5.0	3	4	3.91	3.87	103881	104114	104115	104113 0.035
4.5	0.75	20.0	7.0	4		4.40		103882	104117		
5	0.80	20.0	7.0	4	4	4.90	4.87	103883	104146	104147	104145 0.035
5.5	0.90	20.0	7.0	4		5.40		103884			
6	1.00	20.0	7.0	4	4	5.88	5.85	103885	104165	104166	104164 0.035
7	1.00	25.0	9.0	4	4	6.88		103886	104174	104175	
8	1.25	25.0	9.0	4	4	7.87	7.83	103887	104186	104187	104185 0.035
9	1.25	25.0	9.0	4		8.87		103888	104191		
10	1.50	30.0	11.0	4	4	9.85	9.82	103858	103953	103954	103952 0.035
12	1.75	38.0	14.0	4	4	11.83	11.80	103859	103973	103974	103972 0.035
14	2.00	38.0	14.0	4	4	13.82		103860	103989	103990	
16	2.00	45.0	18.0	4	4	15.82	15.79		104003	104004	* 104002 0.035
18	2.50	45.0	18.0	5		17.79		* 103862	104015		
20	2.50	45.0	18.0	5	5	19.79		103878	104028	104029	
22	2.50	55.0	22.0	5		21.79			104035		
24	3.00	55.0	22.0	5	5	23.76			104043	104044	
27	3.00	65.0	25.0	5		26.76			104058		
30	3.50	65.0	25.0	5	5	29.73			104079	104080	
33	3.50	65.0	25.0	6		32.73			104089		
36	4.00	65.0	25.0	7		35.70			104100		

≤ M1.4

6h

Z5120		NI		13 14 21			Z5120	Z5120 LL		
Z5120 LL		NI		13 14 15 21						
$\varnothing d_1$ M	P mm	d_2 mm	l_1 mm	Z5120	Z5120LL	6g	ID	ID		
2	0.40	16.0	3.5	4	4	1.93	125269	105115		
2.5	0.45	16.0	5.0	4	4	2.43	104779	105116		
2.6	0.45	16.0	5.0	4		2.53	104780			
3	0.50	20.0	5.0	4	5	2.92	104788	105117		
3.5	0.60	20.0	5.0	4		3.41	104789			
4	0.70	20.0	5.0	4	5	3.91	104790	105118		
5	0.80	20.0	7.0	4	5	4.90	104792	105119		
6	1.00	20.0	7.0	4	5	5.88	104795	105120		
7	1.00	25.0	9.0	4		6.88	111424			
8	1.25	25.0	9.0	5	6	7.87	104798	105121		
10	1.50	30.0	11.0	5	6	9.85	104767	105122		
12	1.75	38.0	14.0	5	6	11.83	104770	105123		
14	2.00	38.0	14.0	5		13.82	104773			
16	2.00	45.0	18.0	5		15.82	104776			
18	2.50	45.0	18.0	5		17.79	104778			
20	2.50	45.0	18.0	5		19.79	104783			
24	3.00	55.0	22.0	6		23.76	104787			





































								N5120	N5120 LH	N5120	Z5120	
								6g	6g	6e	6g	
$\varnothing d_1$ MF	P mm	d_2 mm	l_1 mm	\oplus N	\oplus Z	$\rightarrow 6g \leftarrow$	$\rightarrow 6e \leftarrow$	ID	ID	ID	6g - mm	ID
*2	0.25	16.0	5.0	4		1.93		103863				
*2.5	0.35	16.0	5.0	4		2.44		103871				
3	0.35	20.0	5.0	4		2.94		104064				
3.5	0.35	20.0	5.0	4		3.44		104069				
4	0.35	20.0	5.0	4		3.94		104108				
4	0.50	20.0	5.0	4		3.93		104110				
4.5	0.50	20.0	5.0	4		4.43		104116				
5	0.50	20.0	5.0	4	4	4.93	4.90	104141	104142	104140	0.030	104791
5	0.75	20.0	7.0	4		4.90		104143				
5.5	0.50	20.0	5.0	4		5.43		104148				
6	0.50	20.0	5.0	4		5.93		104159	104160			104793
6	0.75	20.0	7.0	4	4	5.90		104162	104163			104794
7	0.50	25.0	9.0	4	4	6.93		104169				
7	0.75	25.0	9.0	4		6.90	6.87	104171		* 104170	0.035	
8	0.50	25.0	9.0	5		7.93		104177				
8	0.75	25.0	9.0	4	4	7.90		104180				104796
8	1.00	25.0	9.0	4	4	7.88	7.85	104183	104184	104182	0.035	104797
9	0.50	25.0	9.0	5		8.93		104188				
9	0.75	25.0	9.0	5		8.90		104189				
9	1.00	25.0	9.0	5		8.88		104190				
10	0.50	30.0	11.0	5		9.93		103942				
10	0.75	30.0	11.0	5	5	9.90	9.87	103945		* 103944	0.035	104765
10	1.00	30.0	11.0	5	5	9.88	9.85	103948	103949	103947	0.035	104766
10	1.25	30.0	11.0	4		9.86		103950	103951			
11	0.75	30.0	11.0	5		10.90		103956				
11	1.00	30.0	11.0	5		10.88		103957				
11	1.25	30.0	11.0	5		10.87		103958				
12	0.50	38.0	10.0	5		11.93		103960				
12	0.75	38.0	10.0	5		11.90	11.87	103962		* 103961	0.035	
12	1.00	38.0	10.0	5	5	11.88	11.85	103965	103966	103964	0.035	104768
12	1.25	38.0	10.0	4		11.86		103967	103968			
12	1.50	38.0	10.0	4	5	11.85		103970	103971			104769
13	1.00	38.0	10.0	5		12.88		103976				



* N5110

P 0.25



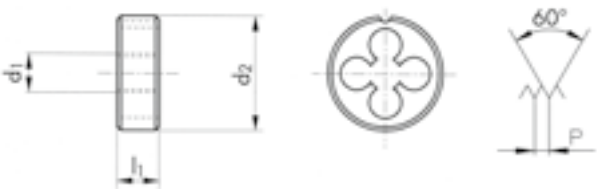

6h

N5120		N5120 LH		N5120		Z5120		N5120	N5120 LH	N5120	Z5120	
												
												
												
$\varnothing d_1$	P	d_2	l_1	\oplus	\oplus	$\rightarrow 6g \leftarrow$	$\rightarrow 6e \leftarrow$	ID	ID	ID	$6g$ - mm	ID
MF	mm	mm	mm	N	Z							
14	0.50	38.0	10.0	5		13.93		103977				
14	0.75	38.0	10.0	5		13.90		103979				
14	1.00	38.0	10.0	5	5	13.88		103981	103982			104771
14	1.25	38.0	10.0	5		13.86		103983				
14	1.50	38.0	10.0	5	5	13.85		103986	103987			104772
15	1.00	38.0	10.0	5		14.88		103991				
15	1.50	38.0	10.0	5		14.85		103992				
16	1.00	45.0	14.0	5	5	15.88	15.85	103996	103997	* 103995	0.035	104774
16	1.25	45.0	14.0	5		15.87		103998				
16	1.50	45.0	14.0	5	5	15.85		104000	104001			104775
17	1.00	45.0	14.0	5		16.88		104005				
18	1.00	45.0	14.0	5		17.88		104008				
18	1.50	45.0	14.0	5	5	17.85		104011	104012			
18	2.00	45.0	14.0	5		17.82		104013				
19	1.00	45.0	14.0	6		18.88		104017				
20	1.00	45.0	14.0	6	6	19.88		104021	104022			104781
20	1.50	45.0	14.0	6	6	19.85		104024	104025			104782
20	2.00	45.0	14.0	6		19.82		104026	* 104027			
21	1.00	45.0	14.0	7		20.88		111386				
22	1.00	55.0	16.0	6		21.88		104030				
22	1.50	55.0	16.0	5	6	21.85		104032				
22	2.00	55.0	16.0	5		21.82		104034				
23	1.00	55.0	16.0	6		22.88		121704				
24	1.00	55.0	16.0	6		23.88		104037				
24	1.50	55.0	16.0	6	6	23.85		104039				
24	2.00	55.0	16.0	6		23.82		104041	104042			
25	1.00	55.0	16.0	6		24.88		104045				
25	1.50	55.0	16.0	6		24.85		104046				
26	1.00	55.0	16.0	7		25.88		104049				
26	1.50	55.0	16.0	6		25.85		104050				
26	2.00	55.0	16.0	6		25.82		104052				
27	1.00	65.0	18.0	6		26.88		104053				
27	1.50	65.0	18.0	6		26.85		104054	* 104055			
27	2.00	65.0	18.0	6		26.82		104056				

							N5120	N5120 LH								
   											  		 			
							 									
$\varnothing d_1$ MF	P mm	d_2 mm	l_1 mm	\oplus	$\rightarrow 6g \leftarrow$	ID	ID									
28	1.00	65.0	18.0	6	27.88	104060										
28	1.50	65.0	18.0	6	27.85	104061										
30	1.00	65.0	18.0	7	29.88	104073										
30	1.50	65.0	18.0	6	29.85	104074										
30	2.00	65.0	18.0	6	29.82	104076										
32	1.50	65.0	18.0	7	31.85	104082	* 104083									
33	1.50	65.0	18.0	7	32.85	104085										
33	2.00	65.0	18.0	7	32.82	104086										
33	3.00	65.0	25.0	7	32.76	* 104088										
34	1.50	65.0	18.0	7	33.85	104091										
35	1.50	65.0	18.0	8	34.85	104092	* 104093									
36	1.50	65.0	18.0	8	35.85	104095	* 104096									
36	2.00	65.0	18.0	8	35.82	104097										
36	3.00	65.0	25.0	7	35.76	104099										
38	1.50	75.0	20.0	7	37.85	104101										
39	1.50	75.0	20.0	7	38.85	104104										
40	1.50	75.0	20.0	8	39.85	104118	* 104119									
40	2.00	75.0	20.0	7	39.82	104120										
42	1.50	75.0	20.0	8	41.85	104122										
42	3.00	75.0	20.0	8	41.76	104125										
45	1.50	90.0	22.0	7	44.85	104127										
45	2.00	90.0	22.0	7	44.82	104129										
48	1.50	90.0	22.0	8	47.85	104133	* 104134									
48	2.00	90.0	22.0	8	47.82	104135										
48	3.00	90.0	22.0	7	47.76	104137										
50	1.50	90.0	22.0	8	49.85	104150										
60	2.00	105.0	22.0	9	59.82	104168										

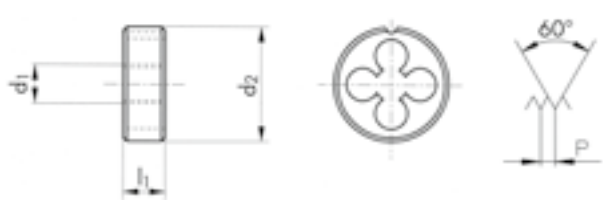
N5110						N5110	N5120		
N5120									
									
									
Ø" d ₁ UNC	P TPI	d ₂ mm	l ₁ mm	⊕	⚙ →2A←	ID	ID		
1	64	16.0	5.0	3	1.79	103893			
2	56	16.0	5.0	4	2.12	103894			
3	48	16.0	5.0	4	2.44	103895			
4	40	16.0	5.0	4	2.76	103896			
5	40	20.0	5.0	4	3.09		104263		
6	32	20.0	7.0	4	3.41		104266		
8	32	20.0	7.0	4	4.07		104269		
10	24	20.0	7.0	4	4.71		104258		
12	24	20.0	7.0	4	5.37		104259		
1/4	20	20.0	7.0	4	6.22		104256		
5/16	18	25.0	9.0	4	7.80		104264		
3/8	16	30.0	11.0	4	9.37		104262		
7/16	14	30.0	11.0	4	10.95		104267		
1/2	13	38.0	14.0	4	12.52		111387		
9/16	12	38.0	14.0	4	14.10		104270		
5/8	11	45.0	18.0	4	15.68		104265		
3/4	10	45.0	18.0	5	18.84		104261		
7/8	9	55.0	22.0	5	22.00		104268		
1	8	55.0	22.0	5	25.16		104257		
1 1/4	7	65.0	25.0	6	31.49		104251		
1 1/2	6	75.0	30.0	6	37.81		104250		
2	4.5	90.0	36.0	7	50.45		* 104260		



N5110							N5110	N5120		
N5120										
										
										
Ø" d ₁ UNF	P TPI	d ₂ mm	l ₁ mm	⊕	⚙ →2A←	ID	ID			
0	80	16.0	5.0	3	1.47	103897				
1	72	16.0	5.0	3	1.79	103898				
2	64	16.0	5.0	4	2.12	103899				
3	56	16.0	5.0	4	2.44	103900				
4	48	16.0	5.0	4	2.77	103901				
5	44	20.0	5.0	4	3.10		104299			
6	40	20.0	5.0	4	3.42		104302			
8	36	20.0	7.0	4	4.08		104305			
10	32	20.0	7.0	4	4.73		104295			
12	28	20.0	7.0	4	5.38		104296			
1/4	28	20.0	7.0	4	6.24		104293			
5/16	24	25.0	9.0	4	7.82		104300			
3/8	24	30.0	11.0	4	9.41		104298			
7/16	20	30.0	11.0	5	10.98		104303			
1/2	20	38.0	10.0	5	12.56		104292			
9/16	18	38.0	10.0	5	14.14		104306			
5/8	18	45.0	14.0	5	15.73		104301			
3/4	16	45.0	14.0	6	18.89		104297			
7/8	14	55.0	16.0	5	22.05		104304			
1	12	55.0	16.0	6	25.21		104294			
1 1/4	12	65.0	18.0	7	31.56		104289			
1 1/2	12	75.0	20.0	7	37.91		111390			

UNEF, UNS, UN









ANSI B1.1

HSS

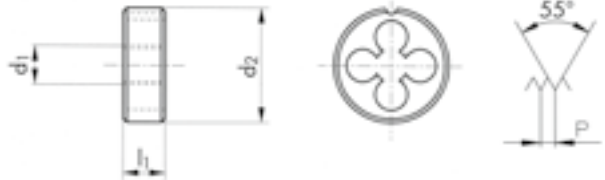

N5120						N5120			
Ø" d ₁ UNEF	P TPI	d ₂ mm	l ₁ mm	⊕	⚡ →2A←	ID			
12	32	20.0	7.0	4	5.39	104278			
1/4	32	20.0	7.0	4	6.25	104275			
5/16	32	25.0	9.0	4	7.84	104283			
3/8	32	30.0	11.0	4	9.42	104282			
7/16	28	30.0	11.0	5	11.00	104285			
1/2	28	38.0	10.0	5	12.59	104274			
9/16	24	38.0	10.0	5	14.17	104287			
5/8	24	45.0	14.0	5	15.75	104284			
3/4	20	45.0	14.0	5	18.91	104281			
13/16	20	45.0	14.0	6	20.50	* 104279			
7/8	20	55.0	16.0	5	22.09	* 104286			
1	20	55.0	16.0	6	25.26	* 104276			
Ø" d ₁ UNS	P TPI	d ₂ mm	l ₁ mm	⊕	⚡ →2A←	ID			
1/4	40	20.0	5.0	4	6.26	104309			
1/4	36	20.0	5.0	4	6.26	104308			
7/16	24	30.0	11.0	5	10.99	104311			
1/2	24	38.0	10.0	5	12.58	104307			
1	14	55.0	16.0	6	25.23	104310			
Ø" d ₁ UN	P TPI	d ₂ mm	l ₁ mm	⊕	⚡ →2A←	ID			
1 1/8	8	65.0	25.0	5	28.33	104246			
1 1/4	8	65.0	25.0	6	31.51	104245			
1 1/2	8	75.0	20.0	7	37.85	104244			
1 3/4	8	90.0	22.0	7	44.20	104247			



						N5120	N5120 LH		
<p>N5120  </p> <p>N5120 LH  LH </p>									
									
									
\varnothing " d_1 G	P TPI	d_2 mm	l_1 mm		 → A ←	ID	ID		
1/8	28	30.0	11.0	5	9.62	103926			
1/4	19	38.0	10.0	5	13.03	103924	103925		
3/8	19	45.0	14.0	5	16.54	103935	103936		
1/2	14	45.0	14.0	6	20.81	103922	103923		
5/8	14	55.0	16.0	5	22.77	103938			
3/4	14	55.0	16.0	6	26.30	103933	103934		
7/8	14	65.0	18.0	6	30.06	103940			
1	11	65.0	18.0	7	33.07	103928			
1 1/4	11	75.0	20.0	8	41.73	103918			
1 3/8	11	90.0	22.0	7	44.14	* 103921			
1 1/2	11	90.0	22.0	8	47.62	103917			
2	11	105.0	22.0	9	59.43	103932			
2 1/2	11	120.0	22.0	10	74.97	103930			

G DIN ISO 228 (BSP)







Z
HSSE

MS
HSS



Z5120		NI		Z5120	MS5120	MS5120		
MS5120								
MS5120								
\varnothing " d ₁	P	d ₂	l ₁	Z	MS	\rightarrow A \leftarrow	ID	
G	TPI	mm	mm					
1/8	28	30.0	11.0	5	5	9.62	104761 * 101339 * 142831	
1/4	19	38.0	10.0	5	5	13.03	104760 101338 * 142832	
3/8	19	45.0	14.0	5	5	16.54	104764 101342 119716	
1/2	14	45.0	14.0	6	6	20.81	104759 101337 119243	
3/4	14	55.0	16.0	6	6	26.30	104763 101341 119648	
1	11	65.0	18.0	8	7	33.07	104762 101340 135186	
1 1/2	11	90.0	22.0		8	47.62	* 142830	



<p>N5120</p>  	<p>N5120</p> 																																																
		 																																															
																																																	
<table border="1"> <thead> <tr> <th>Ø" d₁</th> <th>P</th> <th>d₂</th> <th>l₁</th> <th>⊕</th> <th>ID</th> </tr> <tr> <th>R</th> <th>TPI</th> <th>mm</th> <th>mm</th> <th></th> <th></th> </tr> </thead> <tbody> <tr> <td>1/8</td> <td>28</td> <td>30.0</td> <td>11.0</td> <td>5</td> <td>104226</td> </tr> <tr> <td>1/4</td> <td>19</td> <td>38.0</td> <td>14.0</td> <td>5</td> <td>104225</td> </tr> <tr> <td>3/8</td> <td>19</td> <td>45.0</td> <td>14.0</td> <td>5</td> <td>104230</td> </tr> <tr> <td>1/2</td> <td>14</td> <td>45.0</td> <td>18.0</td> <td>6</td> <td>104224</td> </tr> <tr> <td>3/4</td> <td>14</td> <td>55.0</td> <td>22.0</td> <td>6</td> <td>104229</td> </tr> <tr> <td>1</td> <td>11</td> <td>65.0</td> <td>25.0</td> <td>7</td> <td>104227</td> </tr> </tbody> </table>	Ø" d ₁	P	d ₂	l ₁	⊕	ID	R	TPI	mm	mm			1/8	28	30.0	11.0	5	104226	1/4	19	38.0	14.0	5	104225	3/8	19	45.0	14.0	5	104230	1/2	14	45.0	18.0	6	104224	3/4	14	55.0	22.0	6	104229	1	11	65.0	25.0	7	104227	
Ø" d ₁	P	d ₂	l ₁	⊕	ID																																												
R	TPI	mm	mm																																														
1/8	28	30.0	11.0	5	104226																																												
1/4	19	38.0	14.0	5	104225																																												
3/8	19	45.0	14.0	5	104230																																												
1/2	14	45.0	18.0	6	104224																																												
3/4	14	55.0	22.0	6	104229																																												
1	11	65.0	25.0	7	104227																																												

R 螺纹的车削尺寸 (毫米)

Turning dimensions for R threads (in mm)

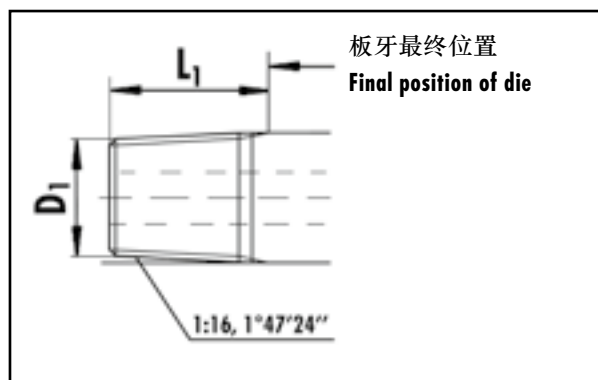

Ø" R	D ₁ 最小 mini mm	D ₁ 最大 maxi mm	D ₁ (参考 guide line) mm	L ₁ (参考 guide line) mm
1/8	9.422	9.534	9.48	8.2
1/4	12.700	12.863	12.78	12.1
3/8	16.181	16.343	16.26	12.5
1/2	20.330	20.555	20.44	16.4
3/4	25.735	25.960	25.85	17.7
1	32.455	32.743	32.60	20.9

N5120			N5120	N5120																																																		
N5120			NPT	NPTF																																																		
<table border="1"> <thead> <tr> <th>Ø" d₁</th> <th>P</th> <th>d₂</th> <th>l₁</th> <th>⊕</th> </tr> <tr> <th>NPT, NPTF</th> <th>TPI</th> <th>mm</th> <th>mm</th> <th></th> </tr> </thead> <tbody> <tr><td>1/16</td><td>27</td><td>25.0</td><td>9.0</td><td>4</td></tr> <tr><td>1/8</td><td>27</td><td>30.0</td><td>11.0</td><td>5</td></tr> <tr><td>1/4</td><td>18</td><td>38.0</td><td>14.0</td><td>5</td></tr> <tr><td>3/8</td><td>18</td><td>45.0</td><td>14.0</td><td>5</td></tr> <tr><td>1/2</td><td>14</td><td>45.0</td><td>18.0</td><td>6</td></tr> <tr><td>3/4</td><td>14</td><td>55.0</td><td>22.0</td><td>6</td></tr> <tr><td>1</td><td>11.5</td><td>65.0</td><td>25.0</td><td>7</td></tr> <tr><td>1 1/4</td><td>11.5</td><td>75.0</td><td>26.0</td><td>8</td></tr> </tbody> </table>			Ø" d ₁	P	d ₂	l ₁	⊕	NPT, NPTF	TPI	mm	mm		1/16	27	25.0	9.0	4	1/8	27	30.0	11.0	5	1/4	18	38.0	14.0	5	3/8	18	45.0	14.0	5	1/2	14	45.0	18.0	6	3/4	14	55.0	22.0	6	1	11.5	65.0	25.0	7	1 1/4	11.5	75.0	26.0	8		
Ø" d ₁	P	d ₂	l ₁	⊕																																																		
NPT, NPTF	TPI	mm	mm																																																			
1/16	27	25.0	9.0	4																																																		
1/8	27	30.0	11.0	5																																																		
1/4	18	38.0	14.0	5																																																		
3/8	18	45.0	14.0	5																																																		
1/2	14	45.0	18.0	6																																																		
3/4	14	55.0	22.0	6																																																		
1	11.5	65.0	25.0	7																																																		
1 1/4	11.5	75.0	26.0	8																																																		
			ID	ID																																																		
			104194																																																			
			104197	* 104207																																																		
			104196																																																			
			104201																																																			
			104195	* 104205																																																		
			104200																																																			
			104198	* 104208																																																		
			104193																																																			

NPT 和 NPTF 型螺纹的车削尺寸 (毫米)

Turning dimensions for NPT and NPTF threads (in mm)

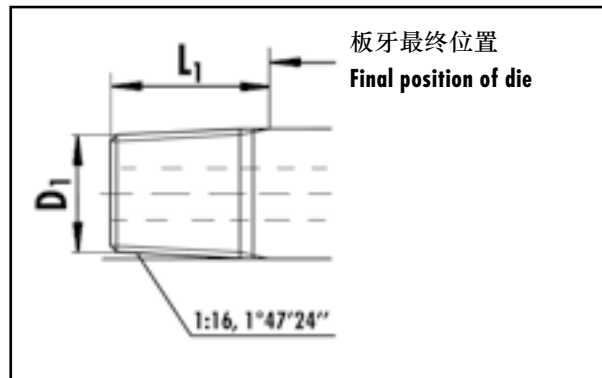

Ø" NPT	D ₁ mini mm	D ₁ maxi mm	D ₁ (guide line) mm	L ₁ (guide line) mm	Ø" NPTF	D ₁ mini mm	D ₁ maxi mm	D ₁ (guide line) mm	L ₁ (guide line) mm
1/16	7.521	7.643	7.58	8.4	1/16	7.525	7.617	7.57	8.4
1/8	9.866	9.988	9.93	8.5	1/8	9.870	9.962	9.92	8.5
1/4	13.099	13.255	13.18	12.7	1/4	13.129	13.215	13.17	12.7
3/8	16.518	16.674	16.60	12.9	3/8	16.548	16.634	16.59	12.9
1/2	20.551	20.713	20.63	16.8	1/2	20.617	20.703	20.66	16.8
3/4	25.866	26.028	25.95	17.1	3/4	25.932	26.018	25.98	17.1
1	32.419	32.591	32.51	21.3	1	32.475	32.561	32.52	21.3
1 1/4	41.144	41.316	41.23	21.9					

N5120			N5120	N5120		
N5120			PG	TR		
$\varnothing d_1$	P	d_2	l_1	\oplus	$\rightarrow \leftarrow$	ID
PG	TPI	mm	mm			
7	20	38.0	10.0	5	12.40	104220
9	18	38.0	10.0	5	15.10	104221
11	18	45.0	14.0	5	18.50	104212
13.5	18	45.0	14.0	6	20.30	104213
16	18	55.0	16.0	5	22.40	104214
21	16	65.0	18.0	6	28.15	* 104215
29	16	65.0	18.0	8	36.85	* 104216
36	16	90.0	22.0	8	46.85	* 104217
42	16	90.0	22.0	10	53.85	* 104218
48	16	105.0	22.0	9	59.15	* 104219
$\varnothing d_1$	P	d_2	l_1	\oplus	$\rightarrow \leftarrow$	ID
TR	mm	mm	mm			
*10	2	38.0	14.0	4	9.91	* 104231
12	3	38.0	14.0	4	11.88	* 104232
16	4	45.0	18.0	4	15.85	* 104234
26	5	65.0	25.0	5	25.83	* 104239
28	5	65.0	25.0	5	27.83	* 104240
32	6	65.0	25.0	6	31.81	* 104242
36	6	65.0	25.0	6	35.81	* 104243
*						

N5120				N5120		N5120 LH			
\varnothing'' W	P TPI	d ₂ mm	l ₁ mm	\oplus		ID	ID		
1/8	40	20.0	5.0	4	3.09	104320			
5/32	32	20.0	7.0	4	3.88	104333			
3/16	24	20.0	7.0	4	4.66	104325			
1/4	20	20.0	7.0	4	6.24	104318			
5/16	18	25.0	9.0	4	7.82	104331			
3/8	16	30.0	11.0	4	9.40	104329			
7/16	14	30.0	11.0	4	10.98	104336			
1/2	12	38.0	14.0	4	12.56	104316			
5/8	11	45.0	18.0	4	15.72	104334	* 104335		
3/4	10	45.0	18.0	5	18.89	104327	* 104328		
7/8	9	55.0	22.0	5	22.10	* 104338			
1	8	55.0	22.0	5	25.27	104322			
1 3/8	6	65.0	25.0	6	34.77	* 104315			





								N5220	N5220	Z5220	
N5220					11	12					
N5220					11	12					
Z5220			NI		13	14	21				
								6g	6e	6g	
$\varnothing d_1$ M	P mm	d_2 mm	l_1 mm	\oplus	TK mm	$\rightarrow 6g \leftarrow$	$\rightarrow 6e \leftarrow$	ID	ID $6g$ - mm	ID	
1.4	0.30	16.0	2.6	4	12.2	1.36		104346			
1.6	0.35	16.0	2.6	4	12.2	1.54		104347			
1.7	0.35	16.0	2.6	4	12.2	1.64		* 104348			
2	0.40	16.0	3.5	4	12.2	1.93	1.90	104367			
2.3	0.40	16.0	3.5	4	12.2	2.23		104369			
2.5	0.45	16.0	3.5	4	12.2	2.43	2.40	104371	* 104370 0.030	104803	
2.6	0.45	16.0	3.5	4	12.2	2.53		104372			
3	0.50	16.0	3.5	4	12.2	2.92	2.90	104375	104374 0.030	104804	
3.5	0.60	16.0	4.0	4	12.2	3.41		104376			
4	0.70	16.0	5.0	4	12.2	3.91	3.87	104380	104379 0.035	104805	
5	0.80	20.0	7.0	4	15.0	4.90	4.87	104384	104383 0.035	104806	
6	1.00	20.0	7.0	4	15.0	5.88	5.85	104388	104387 0.035	104807	
7	1.00	25.0	7.0	4	19.0	6.88		* 104392			
8	1.25	25.0	9.0	4	19.0	7.87	7.83	104397	104396 0.035	104808	
10	1.50	30.0	11.0	6	23.0	9.85	9.82	104354	104353 0.035		
12	1.75	30.0	11.0	6	23.0	11.83		104358			
								$\leq M1.4$	6h		

N5220							N5220			
$\varnothing d_1$ MF	P mm	d_2 mm	l_1 mm		TK mm		ID			
3	0.35	16.0	3.0	4	12.2	2.94	104373			
4	0.35	16.0	3.5	4	12.2	3.94	* 104377			
4	0.50	16.0	4.0	4	12.2	3.93	104378			
5	0.50	20.0	5.0	4	15.0	4.93	104382			
6	0.50	20.0	5.0	4	15.0	5.93	104385			
6	0.75	20.0	7.0	4	15.0	5.90	104386			
7	0.50	25.0	7.0	4	19.0	6.93	* 104389			
7	0.75	25.0	7.0	4	19.0	6.90	* 104390			
8	0.75	25.0	7.0	4	19.0	7.90	* 104394			
8	1.00	25.0	7.0	4	19.0	7.88	* 104395			
10	0.75	30.0	7.0	6	23.0	9.90	* 104350			
10	1.00	30.0	7.0	6	23.0	9.88	* 104351			
10	1.25	25.0	9.0	6	19.0	9.86	* 104352			
12	1.00	30.0	7.0	6	23.0	11.88	* 104355			
12	1.50	30.0	11.0	6	23.0	11.85	* 104356			
14	1.00	35.0	10.0	6	27.5	13.88	* 104359			
14	1.50	35.0	10.0	6	27.5	13.85	* 104360			



N5310						N5310			
$\varnothing d_1$ M	P mm	s mm	l_1 mm	\oplus	$\rightarrow \leftarrow$	ID			
3	0.50	18.0	5.0	3	2.92	104464			
3.5	0.60	18.0	5.0	3	3.41	* 104465			
4	0.70	18.0	5.0	3	3.91	104478			
4.5	0.75	18.0	7.0	3	4.41	* 104479			
5	0.80	18.0	7.0	4	4.90	104487			
6	1.00	18.0	7.0	4	5.88	104493			
7	1.00	21.0	9.0	4	6.88	* 104497			
8	1.25	21.0	9.0	4	7.87	104502			
9	1.25	21.0	9.0	5	8.87	* 104503			
10	1.50	27.0	11.0	4	9.85	104438			
12	1.75	36.0	14.0	4	11.83	104443			
14	2.00	36.0	14.0	4	13.82	104445			
16	2.00	41.0	18.0	4	15.82	104447			
18	2.50	41.0	18.0	5	17.79	104450			
20	2.50	41.0	18.0	5	19.79	104453			
22	2.50	50.0	22.0	5	21.79	104456			
24	3.00	50.0	22.0	5	23.76	104459			
27	3.00	60.0	25.0	5	26.76	* 104463			
30	3.50	60.0	25.0	5	29.73	104468			
52	5.00	85.0	36.0	8	51.66	* 104489			
$\varnothing d_1$ MF	P mm	s mm	l_1 mm	\oplus	$\rightarrow \leftarrow$	ID			
6	0.75	18.0	7.0	4	5.90	* 104492			
8	0.75	21.0	9.0	4	7.90	* 104500			
8	1.00	21.0	9.0	4	7.88	* 104501			
12	1.00	36.0	10.0	4	11.88	* 104440			
20	1.50	41.0	14.0	6	19.85	* 104451			
27	1.50	60.0	18.0	6	26.85	* 104461			
27	2.00	60.0	18.0	6	26.82	* 104462			
30	2.00	60.0	18.0	6	29.82	* 104467			
33	1.50	60.0	18.0	7	32.85	* 104469			
33	2.00	60.0	18.0	7	32.82	* 104470			
38	1.50	70.0	20.0	8	37.85	* 104475			
39	1.50	70.0	20.0	8	38.85	* 104476			
40	1.50	70.0	20.0	8	39.85	* 104480			
64	2.00	115.0	22.0	8	63.82	* 104495			

N5310		N5310	N5310	N5420
N5310				
N5420	 			

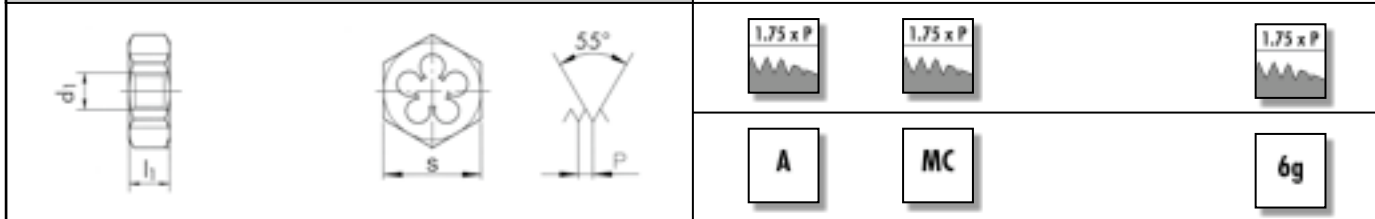

$\varnothing'' d_1$ G	P TPI	s mm	l ₁ mm			ID
1/4	19	36.0	10.0	5	13.03	104428
3/8	19	41.0	14.0	5	16.54	104433
1/2	14	41.0	14.0	6	20.81	104427
5/8	14	50.0	16.0	6	22.77	* 104434
3/4	14	50.0	16.0	6	26.30	104432
7/8	14	60.0	18.0	6	30.06	* 104435
1	11	60.0	18.0	7	33.07	104430
1 3/8	11	85.0	22.0	7	44.14	* 104426
1 3/4	11	100.0	22.0	8	53.57	* 104425

$\varnothing'' d_1$ W	P TPI	s mm	l ₁ mm			ID
1/8	40	18.0	5.0	3	3.09	* 104512
3/16	24	18.0	7.0	3	4.66	* 104515
7/16	14	27.0	11.0	5	10.98	* 104520
9/16	12	36.0	14.0	4	14.14	* 104522
7/8	9	50.0	22.0	5	22.10	* 104521
1 3/8	6	60.0	25.0	6	34.77	* 104508
1 1/2	6	70.0	30.0	6	37.95	* 104504
1 3/4	5	85.0	36.0	6	44.28	* 104507
2	4.5	85.0	36.0	7	50.63	* 104514

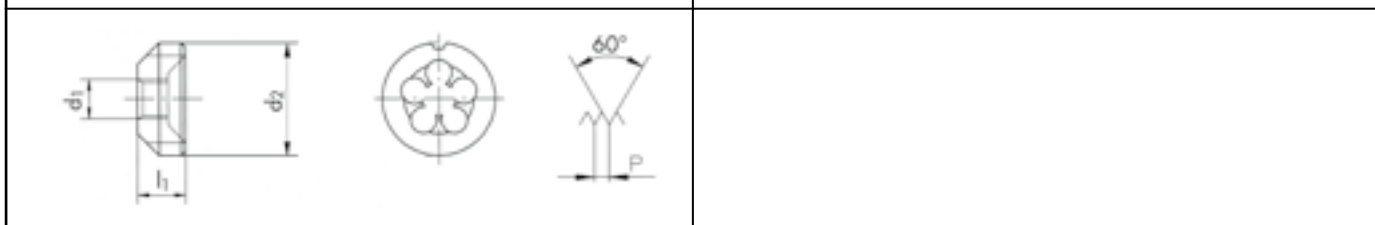

















$\varnothing d_1$ M	P mm	d ₂ mm	l ₁ mm			ID
2.5	0.45	16.0	8.0	4	2.43	* 104527
3.5	0.60	16.0	9.5	4	3.41	* 104530
4	0.70	16.0	9.5	4	3.90	* 104531
8	1.25	25.0	14.0	5	7.86	* 104535

特点 Characteristics								
								
		D5701-1	D5701-2	D5703		D5720	D5722	D5725
M 6H / 6g	ISO DIN 13	266	266	266				
M 6G / 6e	ISO DIN 13			266				
M 6H / 6g LH	ISO DIN 13			266				
MF 6H / 6g	ISO DIN 13	268-269	269	268-269				
MF 6G / 6e	ISO DIN 13			268				
MF 6H / 6g LH	ISO DIN 13			268				
UNC	ANSI B1.1	272		272				
UNF	ANSI B1.1	273		273				
UNEF	ANSI B1.1			273				
NPT	ANSI B1.20.1					275		
NPTF	ANSI B1.20.3					275		
G (BSP)	DIN ISO 228	274	274	274				
PG	DIN 40430							274
EG M	ISO DIN 8140			276				
EG UNC	NASM 33537			276				
EG UNF	NASM 33537			276				





图标说明 - Pictographs

-  通规
"Go"
-  止规
"No-go"
-  通规 / 止规
"Go" / "No-go"
-  公差 6H, 通规
Tolerance 6H, "Go"
-  公差 6G, 通规 / 止规
Tolerance 6G, "Go" / "No-go"
-  公差 6g, 止规
Tolerance 6g, "No-go"
-  左旋螺纹
Left hand thread







			
			
D5704	D5714	D5721	D5723
267	267		
267	267		
267			
270-271	270-271		
270			
272	272		
273	273		
273	273		
		275	
		275	
274	274		
274			







		D5701-1	D5701-2	D5703	D5703 LH	D5703	
D5701-1 M1 - M1.4 =  D5703 M1 - M1.4 = 							
					 		
∅ d ₁ M	P mm	ID	ID	ID	ID	ID	
1	0.25			100242			
1.1	0.25			100243			
1.2	0.25			100244			
1.4	0.30			100245			
1.6	0.35			100246	* 110168		
1.7	0.35			100247			
1.8	0.35			100248	* 110169		
2	0.40			100278	105159	104982	
2.2	0.45			100280			
2.3	0.40			100281			
2.5	0.45			100283	105160	104979	
2.6	0.45	* 100064		100285			
3	0.50			100310	104964	104976	
3.5	0.60			100312		104977	
4	0.70			100333	104966	104978	
4.5	0.75	* 100114					
5	0.80			100348	104967	104980	
6	1.00			100363	104968	104981	
7	1.00			100369	* 110186		
8	1.25			100373	104969	104983	
9	1.25			100375			
10	1.50			100253	104970	104984	
11	1.50			* 100256			
12	1.75			100261	104971	104985	
14	2.00	* 100045		100266		104986	
16	2.00			100271	104973	104987	
18	2.50	* 100055		100276		* 104988	
20	2.50	* 100068		100289	104975	104989	
22	2.50	* 100072		100293	* 110178		
24	3.00	* 100076		100297	110179		
27	3.00			100305	* 110180		
30	3.50			100316			
33	3.50	* 100101		100322			
36	4.00	* 100107		100328			
39	4.00	* 100109		100330			
42	4.50	100119	142843				
45	4.50	100122	142844				
48	5.00	100125	142845				
52	5.00	100132	142846				
56	5.50	100137	142847				

M ISO DIN 13 DIN ISO 1502



		D5704	D5704 LH	D5704	D5714	D5714		
D5704 M1 - M1.4 = 								
D5714 M1 - M1.4 = 								
Ø d ₁ M	P mm	ID	ID	ID	ID	ID		
1	0.25	100480			110419			
1.2	0.25	100481			110420			
1.4	0.30	100482			110421			
1.6	0.35	100483			110422			
1.7	0.35	100484			111439			
1.8	0.35	100485			110423			
2	0.40	100515	105006	* 104997	100734	* 142833		
2.2	0.45	100517			100735			
2.3	0.40	100518			100736			
2.5	0.45	100520		* 104991	100737	* 142834		
2.6	0.45	100522			100738			
3	0.50	100547	105001	* 104990	100763	* 142835		
3.5	0.60	100549	110302	* 110301	100765	* 142836		
4	0.70	100570	105003	* 104992	100774	* 142837		
5	0.80	100585	105004	* 104993	100778	* 143406		
6	1.00	100600	105005	* 104994	100781	* 135556		
7	1.00	100605	* 126560	* 104995	100783	* 142840		
8	1.25	100611	105007	* 104996	100786	* 142841		
9	1.25	100610			100788			
10	1.50	100490	105008	* 104998	100711	* 142842		
11	1.50	* 100493			* 100713			
12	1.75	100498	105009		100718			
14	2.00	100503	105010		100723			
16	2.00	100508	105011	* 105000	100728			
18	2.50	100513	105012		100733			
20	2.50	100526	105013		100742			
22	2.50	100530	110298		100746			
24	3.00	100534			100750			
27	3.00	100542			100758			
30	3.50	100553			100769			
33	3.50	* 100559			* 100770			
36	4.00		* 110305					
39	4.00				* 110440			
42	4.50	* 100577						
45	4.50	* 100580			* 110448			
48	5.00				* 110451			
52	5.00	* 100590			* 110456			
56	5.50	* 100595			* 110461			





		D5701-1	D5703	D5703 LH	D5703		
							
				 			
$\varnothing d_1$ MF	P mm	ID	ID	ID	ID		
2.5	0.35		100282				
3	0.35		100309				
4	0.35		100331				
4	0.50		100332				
4.5	0.50		* 100334				
5	0.50		100347	105016	105045		
6	0.50	* 100140	100361	110184			
6	0.75		100362		105046		
7	0.50		100367				
7	0.75	* 100147	100368				
8	0.50	* 100149	100370				
8	0.75		100371	105018	105047		
8	1.00	* 100151	100372	105019	105048		
9	1.00		100374				
10	0.50		100249				
10	0.75		100250				
10	1.00		100251	105020	105049		
10	1.25	* 100031	100252				
11	0.75	* 100033					
11	1.00	* 100034	100255				
12	0.75	* 100036	100257				
12	1.00		100258	105021	105050		
12	1.25		100259				
12	1.50	* 100039	100260	105022			
14	1.00		100263	110171			
14	1.25		100264				
14	1.50	* 100044	100265	105023	105052		
15	1.00	* 100046	100267				
15	1.50		100268				
16	1.00		100269	110172			
16	1.50	* 100049	100270	105024	105053		
17	1.00		100272				
18	1.00		100273				
18	1.50	* 100053	100274	105025	105054		
18	2.00	* 100054	100275				
20	1.00	* 100065	100286				
20	1.50		100287	105026			
20	2.00	* 100067	100288		* 110176		
22	1.00		100290				
22	1.50		100291	110177			
22	2.00		100292				
24	1.00		100294				
24	1.50		100295				
24	2.00		100296				

		D5701-1	D5701-2	D5703			
							
							
$\varnothing d_1$ MF	P mm	ID	ID	ID			
25	1.00	* 100077		100298			
25	1.50			100299			
25	2.00			100300			
26	1.00			100301			
26	1.50	* 100081		100302			
27	1.50	* 100082		100303			
27	2.00	* 100083		100304			
28	1.00			100306			
28	1.50	* 100086		100307			
28	2.00	* 100087		100308			
30	1.00	* 100092		100313			
30	1.50			100314			
30	2.00			100315			
32	1.00			100317			
32	1.50	* 100097		100318			
32	2.00			100319			
33	1.50			100320			
33	2.00	* 100100		100321			
35	1.50	* 100102		100323			
36	1.50	* 100104		100325			
36	2.00			100326			
36	3.00			100327			
38	1.50	* 100108		100329			
40	1.50			100336			
40	2.00			100337			
42	1.50	100117	142848				
42	2.00	100118	142849				
45	1.50	100120	110127				
45	2.00	100121	142851				
48	1.50	100123	123180				
48	2.00	100124	142853				
50	1.50	100128	142854				
50	2.00	100129	142855				
52	1.50	100130	123428				
52	2.00	100131	142857				
55	1.50	100133	123468				
55	2.00	100134	142859				
56	1.50	100135	142860				
56	2.00	100136	142861				
58	1.50	100138	142862				
58	2.00	100139	142863				
60	1.50	100143	142864				
60	2.00	100144	142865				











		D5704	D5704 LH	D5714			
							
							
$\varnothing d_1$ MF	P mm	ID	ID	ID			
2.5	0.35	100519		110427			
3	0.35	100546		100762			
3.5	0.35	100548		100764			
4	0.35	100568		100772			
4	0.50	100569		100773			
4.5	0.50	100571		100775			
5	0.50	100584	105057	100777			
6	0.50	100598	110307	100779			
6	0.75	100599	105058	100780			
7	0.50	100603		110467			
7	0.75	100604		100782			
8	0.50	100606					
8	0.75	100607	* 105059	100784			
8	1.00	100608	105060	100785			
9	1.00	100609		100787			
10	0.50	100486		100707			
10	0.75	100487		100708			
10	1.00	100488	105061	100709			
10	1.25	100489		100710			
11	1.00	100492		100712			
12	0.75	100494		100714			
12	1.00	100495	105062	100715			
12	1.25	100496		100716			
12	1.50	100497	105063	100717			
13	1.00	100499		100719			
14	1.00	100500	110290	100720			
14	1.25	100501		100721			
14	1.50	100502	105064	100722			
15	1.00	100504		100724			
15	1.50	100505		100725			
16	1.00	100506	110292	100726			
16	1.50	100507	105065	100727			
17	1.00	100509		100729			
18	1.00	100510		100730			
18	1.50	100511	105066	100731			
20	1.00	100523	110295	100739			
20	1.50	100524	105067	100740			
20	2.00	100525		100741			
22	1.00	100527		100743			
22	1.50	100528		100744			
22	2.00	100529		100745			
24	1.00	100531		100747			
24	1.50	100532		100748			
24	2.00	100533					

		D5704	D5714				
							
							
$\varnothing d_1$ MF	P mm	ID	ID				
25	1.00	100535					
25	1.50	100536					
26	1.00	100538	* 100754				
26	1.50	100539	* 100755				
27	1.50	100540	* 100756				
27	2.00	100541	* 100757				
28	1.00	100543					
28	1.50	100544	* 100760				
30	1.00	100550					
30	1.50	100551					
30	2.00	100552	* 100768				
32	1.00	100554					
32	1.50	100555					
32	2.00	100556	* 110431				
33	1.50	100557	* 110432				
33	2.00	100558	* 110433				
35	1.50	100560					
36	1.50	100562					
36	2.00	100563					
36	3.00	100564					
38	1.50	100566	* 110439				
40	1.50	100573	* 110441				
42	1.50	100575					
42	2.00	100576					
45	1.50	100578					
45	2.00	100579	* 110447				
48	1.50	100581	* 110449				
48	2.00	100582					
50	1.50	100586	* 110452				
50	2.00	100587	* 110453				
52	1.50		* 110454				
52	2.00	100589					
55	1.50	100591					
55	2.00	100592	* 110458				
56	1.50	100593	* 110459				
56	2.00	100594	* 110460				
58	1.50	100596					
58	2.00	100597	* 110463				
60	1.50	100601	* 110464				
60	2.00	105014					











UNC













ANSI B1.1
ANSI B1.2

		D5701-1	D5703	D5704	D5714		
							
							
Ø" d ₁ UNC	P TPI	ID	ID	ID	ID		
1	64		100408	110347	110473		
2	56	* 110076	100414	110353	110479		
3	48	* 110077	100416		* 110480		
4	40	* 110080	110224	110357	110483		
5	40		100420	* 110358	* 110484		
6	32	* 110084	100423	110361	110487		
8	32	* 110087	100426	110364	110490		
10	24	* 110074	100412	110351	110477		
12	24		100413				
1/4	20		100410	110349	110475		
5/16	18	* 110082	100421	110359	110485		
3/8	16	* 110079	100418	110356	110482		
7/16	14	* 110085	100424	110362	110488		
1/2	13	* 110071	100409	110348	110474		
9/16	12		100427	110365	* 110491		
5/8	11	* 110083	100422	110360			
3/4	10	* 110078	100417	110355	* 110481		
7/8	9		100425	110363	* 110489		
1	8	* 110073	100411	110350	* 110476		
1 1/8	7	* 110068	100405	* 110345	* 110471		
1 1/4	7	* 110067	100404	* 110344	* 110470		
1 3/8	6	* 110069	100407	* 110346	* 110472		
1 1/2	6	* 110066	100403	* 110343	* 110469		

UNF, UNEF ANSI B1.1 ANSI B1.2

		D5701-1	D5703	D5704	D5714		
							
							
\varnothing " d ₁ UNF	P TPI	ID	ID	ID	ID		
0	80		110246	* 110378	* 110503		
1	72	* 110105	110251	110383	110508		
2	64		110256	110389	110514		
3	56	* 110112	110257	110390	110515		
4	48		110260	110393	110518		
5	44	* 110116	* 110261				
6	40		110264	110397	110522		
8	36	* 110122	110267	* 110400			
10	32		110254	110387	110512		
12	28		110255	110388	110513		
1/4	28	* 110107	110006	110385	110510		
5/16	24	* 110117	110262	110395	110520		
3/8	24	* 110114	110259	110392	110517		
7/16	20	* 110120	110265	110398	111440		
1/2	20	* 110106	110252	110384	110509		
9/16	18		110268	110401			
5/8	18	* 110118	110263	110396			
3/4	16		110258	110391	* 110516		
7/8	14		110266	110399			
1	12		128646	110386			
1 1/8	12	* 110103	110249	110381	* 110506		
1 1/4	12	* 110102	110248	110380	* 110505		
1 3/8	12	* 110104	110250	* 110382	* 110507		
1 1/2	12		110247	110379			
\varnothing " d ₁ UNEF	P TPI	ID	ID	ID	ID		
12	32		110238	* 110370	* 110495		
1/4	32		110236	110368	110493		
5/16	32		110241	110373	110498		
3/8	32		110240	110372	110497		
7/16	28		110243	110375	110500		
1/2	28		110235	110367	110492		
9/16	24		110245	110377	110502		
5/8	24		110242	110374	110499		
3/4	20		110239	110371	110496		
7/8	20		110244		* 110501		
1	20		110253	110369	110494		





		D5701-1	D5701-2	D5703	D5704	D5714	D5725
							
							
\varnothing " d ₁ G	P TPI	ID	ID	ID	ID	ID	
1/8	28	* 110044		110009	110277	110408	
1/4	19			110003	110276	110407	
3/8	19	* 110052		110162	110284	110415	
1/2	14			110001	110275	110406	
5/8	14			110164	110286	110417	
3/4	14			110161	110283	110414	
7/8	14	* 110054		110165	* 110287	* 110418	
1	11			110156	110278	110409	
1 1/8	11			110154		* 110404	
1 1/4	11	110041	119459		110272		
1 1/2	11	110040	119429		110271		
1 3/4	11	110043	142868		110274	* 110405	
2	11	110050	110126		110282		
2 1/4	11					* 110411	
2 1/2	11		* 110125				
2 3/4	11					* 110412	
3	11				* 110285	* 110416	
\varnothing d ₁ PG	P TPI	ID				ID	ID
7	20						110216
9	18						110217
11	18						110205
13.5	18						110209
16	18					* 110330	110210
21	16					* 110331	110211
29	16					* 110332	110212

NPT, NPTF



ANSI B1.20.1 / ANSI B1.20.3

ANSI B1.20.1 / ANSI B1.20.5

		D5720	D5721				
							
							
\varnothing " d ₁ NPT	P TPI	ID	ID				
1/16	27	110190	110313				
1/8	27	110193	110316				
1/4	18	110192	110315				
3/8	18	110197	110320				
1/2	14	110191	110314				
3/4	14	110196	110319				
1	11.5	110194	110317				
1 1/4	11.5	110189	110312				
1 1/2	11.5	110188	110311				
2	11.5	110195	110318				
\varnothing " d ₁ NPTF	P TPI	ID	ID				
1/8	27	110201	* 110324				
1/4	18	110200	* 110323				
3/8	18	110204	* 110327				
1/2	14	110199	* 110322				
3/4	14	110203	* 110326				
1	11.5	110202	* 110325				



EG M ISO DIN 8140 ISO DIN 1502 EG UNC, EG UNF NASM 33537

		D5703	D5703	D5703			
							
							
$\varnothing d_1$ EG M	P mm	ID					
2.5	0.45	110132					
3	0.50	110133					
4	0.70	110134					
5	0.80	110135					
6	1.00	110136					
8	1.25	110137					
10	1.50	110128					
12	1.75	110129					
16	2.00	110131					
\varnothing " d ₁ EG UNC	P TPI	ID					
4	40	170252					
6	32	170253					
8	32	170254					
10	24	170255					
1/4	20	170256					
5/16	18	170257					
3/8	16	170258					
\varnothing " d ₁ EG UNF	P TPI	ID					
6	40	170259					
8	36	170260					
10	32	161020					
1/4	28	151790					
5/16	24	170261					
3/8	24	160134					

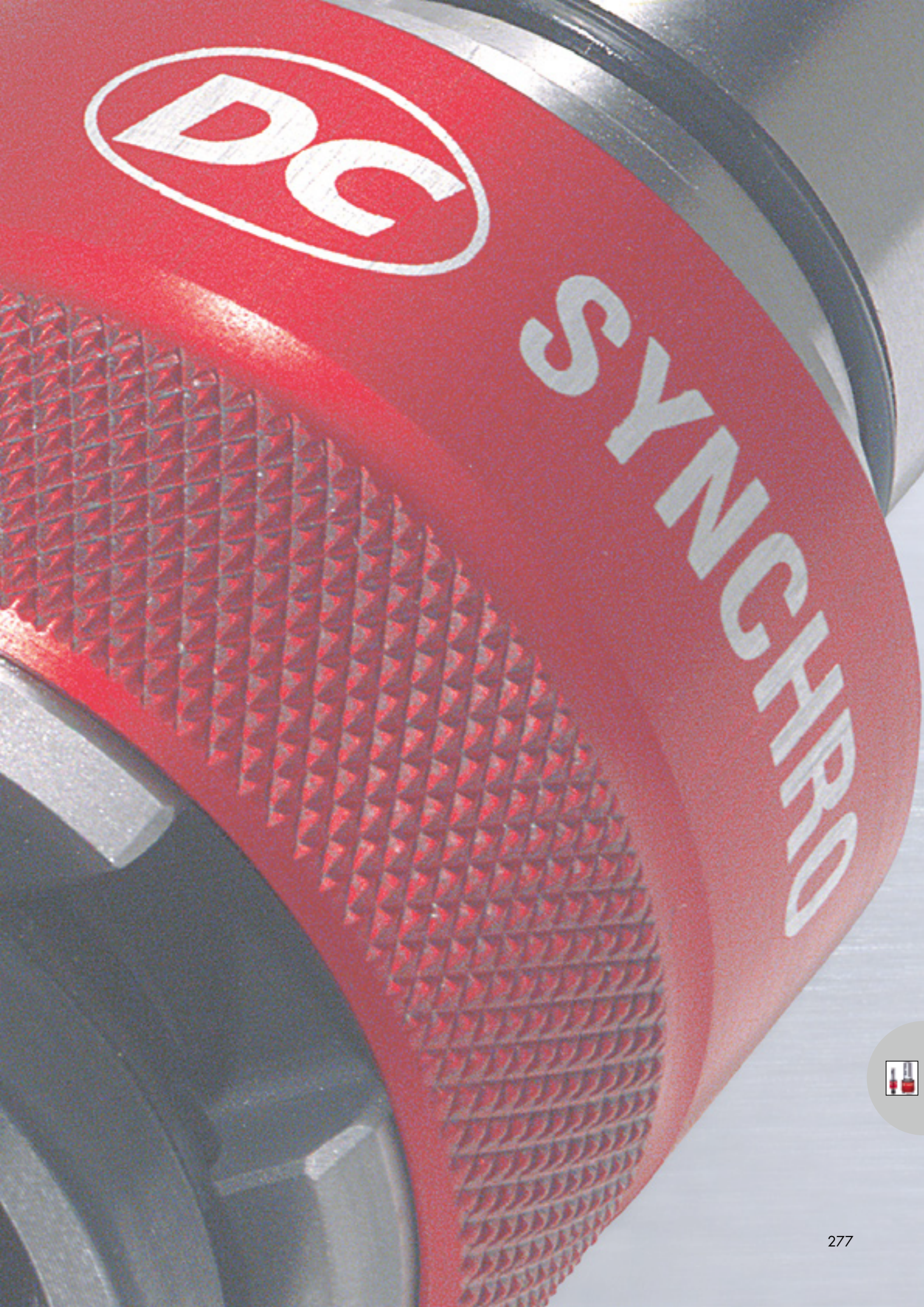

SYNCHRO



SRT 带轴向减震器攻丝夹头

Tapping chucks with axial shock absorber



只适用于刚性攻丝
Only for rigid tapping

DIN 69 893 A					SRT-HSK63-312	SRT-HSK63-520	SRT-HSK63-1433
<h1>HSK</h1>							
					<div style="display: flex; justify-content: space-around;"> <div style="border: 1px solid black; padding: 2px; text-align: center;"><50 bar</div> <div style="border: 1px solid black; padding: 2px; text-align: center;"><50 bar</div> <div style="border: 1px solid black; padding: 2px; text-align: center;"><50 bar</div> </div>		
D_1	L_1				ID	ID	ID
mm	mm			282			
M3 - M12	36	72.0	HSK A 63	S1	170111		
M5 - M20	53	89.0	HSK A 63	S2		170112	
M14 - M33	78	121.0	HSK A 63	S3			170114
MAS/BT Form AD + B					SRT-BT40-312	SRT-BT40-520	SRT-BT40-1433
<h1>BT</h1>							
					<div style="display: flex; justify-content: space-around;"> <div style="border: 1px solid black; padding: 2px; text-align: center;"><50 bar</div> <div style="border: 1px solid black; padding: 2px; text-align: center;"><50 bar</div> <div style="border: 1px solid black; padding: 2px; text-align: center;"><50 bar</div> </div>		
D_1	L_1				ID	ID	ID
mm	mm			282			
M3 - M12	36	71.0	BT 40	S1	170133		
M5 - M20	53	85.0	BT 40	S2		170134	
M14 - M33	78	121.0	BT 40	S3			170135

SRT 带轴向减震器攻丝夹头

Tapping chucks with axial shock absorber



只适用于刚性攻丝
Only for rigid tapping

DIN 69 871 Form AD + B					SRT-SK40-312	SRT-SK40-520	SRT-SK40-1433																				
<h1>SK</h1>																											
					ID	ID	ID																				
<table border="1"> <thead> <tr> <th></th> <th>D_1 mm</th> <th>L_1 mm</th> <th></th> <th></th> </tr> </thead> <tbody> <tr> <td>M3 - M12</td> <td>36</td> <td>65.0</td> <td>SK 40</td> <td>S1</td> </tr> <tr> <td>M5 - M20</td> <td>53</td> <td>79.0</td> <td>SK 40</td> <td>S2</td> </tr> <tr> <td>M14 - M33</td> <td>78</td> <td>115.0</td> <td>SK 40</td> <td>S3</td> </tr> </tbody> </table>						D_1 mm	L_1 mm			M3 - M12	36	65.0	SK 40	S1	M5 - M20	53	79.0	SK 40	S2	M14 - M33	78	115.0	SK 40	S3	170124	170125	170126
	D_1 mm	L_1 mm																									
M3 - M12	36	65.0	SK 40	S1																							
M5 - M20	53	79.0	SK 40	S2																							
M14 - M33	78	115.0	SK 40	S3																							
DIN 69 871 Form AD + B					SRT-SK50-520	SRT-SK50-1433	SRT-SK50-2248																				
<h1>SK</h1>																											
					ID	ID	ID																				
<table border="1"> <thead> <tr> <th></th> <th>D_1 mm</th> <th>L_1 mm</th> <th></th> <th></th> </tr> </thead> <tbody> <tr> <td>M5 - M20</td> <td>53</td> <td>79.0</td> <td>SK 50</td> <td>S2</td> </tr> <tr> <td>M14 - M33</td> <td>78</td> <td>115.0</td> <td>SK 50</td> <td>S3</td> </tr> <tr> <td>M22 - M48</td> <td>96</td> <td>170.0</td> <td>SK 50</td> <td>S4</td> </tr> </tbody> </table>						D_1 mm	L_1 mm			M5 - M20	53	79.0	SK 50	S2	M14 - M33	78	115.0	SK 50	S3	M22 - M48	96	170.0	SK 50	S4	170128	170129	170130
	D_1 mm	L_1 mm																									
M5 - M20	53	79.0	SK 50	S2																							
M14 - M33	78	115.0	SK 50	S3																							
M22 - M48	96	170.0	SK 50	S4																							



SRT 带轴向减震器攻丝夹头

Tapping chucks with axial shock absorber



只适用于刚性攻丝
Only for rigid tapping













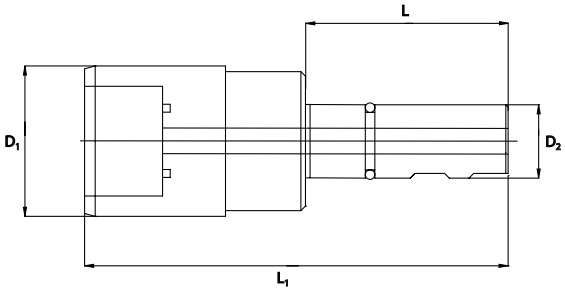









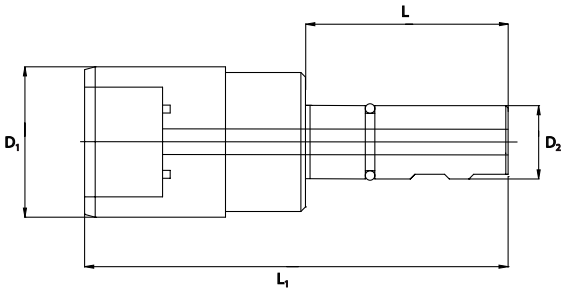

DIN 1835 B		SRT032-D6	SRT054-D12	ER8																																			
<h1>SRT nano</h1>																																							
<p>SRT032 / SRT054 D9865-</p>																																							
	<table border="1"> <thead> <tr> <th>D</th> <th>D₁</th> <th>D₂</th> <th>L</th> <th>L₁</th> <th>L₂</th> </tr> <tr> <th>mm</th> <th>mm</th> <th>mm</th> <th>mm</th> <th>mm</th> <th>mm</th> </tr> </thead> <tbody> <tr> <td>M0.3 - M2</td> <td>12</td> <td>11</td> <td>6</td> <td>25</td> <td>40</td> </tr> <tr> <td>M0.5 - M4</td> <td>12</td> <td>20</td> <td>12</td> <td>33</td> <td>59</td> </tr> </tbody> </table>	D	D ₁	D ₂	L	L ₁	L ₂	mm	mm	mm	mm	mm	mm	M0.3 - M2	12	11	6	25	40	M0.5 - M4	12	20	12	33	59	ID	ID												
D	D ₁	D ₂	L	L ₁	L ₂																																		
mm	mm	mm	mm	mm	mm																																		
M0.3 - M2	12	11	6	25	40																																		
M0.5 - M4	12	20	12	33	59																																		
		157610	127413																																				
No	<table border="1"> <thead> <tr> <th>D₂</th> <th>L₃</th> <th>d₂</th> </tr> <tr> <th>mm</th> <th>mm</th> <th>mm</th> </tr> </thead> <tbody> <tr> <td>ER8-0200</td> <td>8.5</td> <td>13.5</td> <td>2.0</td> </tr> <tr> <td>ER8-0250</td> <td>8.5</td> <td>13.5</td> <td>2.5</td> </tr> <tr> <td>ER8-0300</td> <td>8.5</td> <td>13.5</td> <td>3.0</td> </tr> <tr> <td>ER8-0350</td> <td>8.5</td> <td>13.5</td> <td>3.5</td> </tr> <tr> <td>ER8-0400</td> <td>8.5</td> <td>13.5</td> <td>4.0</td> </tr> <tr> <td>ER8-0450</td> <td>8.5</td> <td>13.5</td> <td>4.5</td> </tr> </tbody> </table>	D ₂	L ₃	d ₂	mm	mm	mm	ER8-0200	8.5	13.5	2.0	ER8-0250	8.5	13.5	2.5	ER8-0300	8.5	13.5	3.0	ER8-0350	8.5	13.5	3.5	ER8-0400	8.5	13.5	4.0	ER8-0450	8.5	13.5	4.5		ID						
D ₂	L ₃	d ₂																																					
mm	mm	mm																																					
ER8-0200	8.5	13.5	2.0																																				
ER8-0250	8.5	13.5	2.5																																				
ER8-0300	8.5	13.5	3.0																																				
ER8-0350	8.5	13.5	3.5																																				
ER8-0400	8.5	13.5	4.0																																				
ER8-0450	8.5	13.5	4.5																																				
				118895																																			
				118896																																			
				118897																																			
				118898																																			
				118899																																			
				118900																																			
DIN 1835 B		SRT312-D20	SRT312-D25	SRT520-D25																																			
<h1>SRT short</h1>																																							
	<table border="1"> <thead> <tr> <th>D₁</th> <th>D₂</th> <th>L</th> <th>L₁</th> <th></th> <th></th> <th>282</th> </tr> <tr> <th>mm</th> <th>mm</th> <th>mm</th> <th>mm</th> <th></th> <th></th> <th></th> </tr> </thead> <tbody> <tr> <td>M3 - M12</td> <td>39</td> <td>20</td> <td>47</td> <td>86.0</td> <td>S1</td> <td></td> </tr> <tr> <td>M3 - M12</td> <td>39</td> <td>25</td> <td>53</td> <td>90.0</td> <td>S1</td> <td></td> </tr> <tr> <td>M5 - M20</td> <td>56</td> <td>25</td> <td>53</td> <td>110.0</td> <td>S2</td> <td></td> </tr> </tbody> </table>	D ₁	D ₂	L	L ₁			282	mm	mm	mm	mm				M3 - M12	39	20	47	86.0	S1		M3 - M12	39	25	53	90.0	S1		M5 - M20	56	25	53	110.0	S2		ID	ID	ID
D ₁	D ₂	L	L ₁			282																																	
mm	mm	mm	mm																																				
M3 - M12	39	20	47	86.0	S1																																		
M3 - M12	39	25	53	90.0	S1																																		
M5 - M20	56	25	53	110.0	S2																																		
		162832	162831	162833																																			

SRT 带轴向减震器攻丝夹头

Tapping chucks with axial shock absorber



只适用于刚性攻丝
Only for rigid tapping

DIN 1835 B	SRT-1D20-312	SRT-1D25-312	SRT-2D25-520																												
SRT																															
	 <50 bar	 <50 bar	 <50 bar																												
<table border="1"> <thead> <tr> <th></th> <th>D₁ mm</th> <th>D₂ mm</th> <th>L mm</th> <th>L₁ mm</th> <th></th> <th> 282</th> </tr> </thead> <tbody> <tr> <td>M3 - M12</td> <td>36</td> <td>20</td> <td>51.0</td> <td>97</td> <td>S1</td> <td></td> </tr> <tr> <td>M3 - M12</td> <td>36</td> <td>25</td> <td>57.0</td> <td>103</td> <td>S1</td> <td></td> </tr> <tr> <td>M5 - M20</td> <td>53</td> <td>25</td> <td>57.0</td> <td>131</td> <td>S2</td> <td></td> </tr> </tbody> </table>		D ₁ mm	D ₂ mm	L mm	L ₁ mm		 282	M3 - M12	36	20	51.0	97	S1		M3 - M12	36	25	57.0	103	S1		M5 - M20	53	25	57.0	131	S2		ID 170140	ID 170020	ID 170141
	D ₁ mm	D ₂ mm	L mm	L ₁ mm		 282																									
M3 - M12	36	20	51.0	97	S1																										
M3 - M12	36	25	57.0	103	S1																										
M5 - M20	53	25	57.0	131	S2																										
DIN 1835 B	SRT-2D32-520	SRT-3D25-1433	SRT-3D32-1433																												
SRT																															
	 <50 bar	 <50 bar	 <50 bar																												
<table border="1"> <thead> <tr> <th></th> <th>D₁ mm</th> <th>D₂ mm</th> <th>L mm</th> <th>L₁ mm</th> <th></th> <th> 282</th> </tr> </thead> <tbody> <tr> <td>M5 - M20</td> <td>53</td> <td>32</td> <td>61.5</td> <td>135.5</td> <td>S2</td> <td></td> </tr> <tr> <td>M14 - M33</td> <td>78</td> <td>25</td> <td>57.0</td> <td>164.5</td> <td>S3</td> <td></td> </tr> <tr> <td>M14 - M33</td> <td>78</td> <td>32</td> <td>61.5</td> <td>169.0</td> <td>S3</td> <td></td> </tr> </tbody> </table>		D ₁ mm	D ₂ mm	L mm	L ₁ mm		 282	M5 - M20	53	32	61.5	135.5	S2		M14 - M33	78	25	57.0	164.5	S3		M14 - M33	78	32	61.5	169.0	S3		ID 170142	ID 170143	ID 170144
	D ₁ mm	D ₂ mm	L mm	L ₁ mm		 282																									
M5 - M20	53	32	61.5	135.5	S2																										
M14 - M33	78	25	57.0	164.5	S3																										
M14 - M33	78	32	61.5	169.0	S3																										





SRT					S1-	S2-	S3-	S4-
No	D ₁ mm	D ₂ mm	d ₂ mm	α mm	ID	ID	ID	ID
S1-0028	30	19.0	2.8	2.1	129915			
S1-0035	30	19.0	3.5	2.7	129916			
S1-0045	30	19.0	4.5	3.4	129918			
S1-0060	30	19.0	6.0	4.9	129920			
S1-0070	30	19.0	7.0	5.5	129921			
S1-0080	30	19.0	8.0	6.2	129922			
S1-0090	30	19.0	9.0	7.0	129923			
S1-0100	30	19.0	10.0	8.0	129924			
S1-0110	30	19.0	11.0	9.0	129925			
S2-0060	48	31.0	6.0	4.9		129927		
S2-0070	48	31.0	7.0	5.5		129928		
S2-0080	48	31.0	8.0	6.2		129929		
S2-0090	48	31.0	9.0	7.0		129930		
S2-0100	48	31.0	10.0	8.0		129931		
S2-0110	48	31.0	11.0	9.0		148303		
S2-0120	48	31.0	12.0	9.0		129932		
S2-0140	48	31.0	14.0	11.0		129933		
S2-0160	48	31.0	16.0	12.0		129934		
S2-0180	48	31.0	18.0	14.5		151355		
S3-0110	70	48.0	11.0	9.0			170145	
S3-0120	70	48.0	12.0	9.0			170146	
S3-0140	70	48.0	14.0	11.0			170147	
S3-0160	70	48.0	16.0	12.0			170148	
S3-0180	70	48.0	18.0	14.5			170149	
S3-0200	70	48.0	20.0	16.0			170150	
S3-0220	70	48.0	22.0	18.0			170151	
S3-0250	70	48.0	25.0	20.0			170152	
S4-0180	96	60.0	18.0	14.5				170153
S4-0200	96	60.0	20.0	16.0				170154
S4-0220	96	60.0	22.0	18.0				170155
S4-0250	96	60.0	25.0	20.0				170156
S4-0280	96	60.0	28.0	22.0				170157
S4-0320	96	60.0	32.0	24.0				170158
S4-0360	96	60.0	36.0	29.0				170159

带过载离合器夹头
Inserts with slipping clutch



CLASSIC

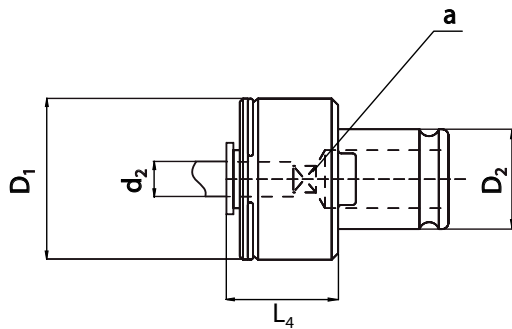

SC1-

SC2-

SC3-

SC4-











No	D_1 mm	D_2 mm	d_2 mm	a mm	L_4 mm	ID	ID	ID	ID
SC1-0028	32	19.0	2.8	2.1	25	170160			
SC1-0035	32	19.0	3.5	2.7	25	170161			
SC1-0045	32	19.0	4.5	3.4	25	170162			
SC1-0060	32	19.0	6.0	4.9	25	170163			
SC1-0070	32	19.0	7.0	5.5	25	170164			
SC1-0080	32	19.0	8.0	6.2	25	170165			
						170166			
						170167			
SC1-0090	32	19.0	9.0	7.0	25				
SC1-0100	32	19.0	10.0	8.0	25				
							170168		
							170169		
SC2-0060	50	31.0	6.0	4.9	34				
SC2-0070	50	31.0	7.0	5.5	34				
							170170		
							170171		
							170172		
SC2-0080	50	31.0	8.0	6.2	34				
SC2-0090	50	31.0	9.0	7.0	34				
							170173		
							170174		
							170175		
SC2-0100	50	31.0	10.0	8.0	34				
SC2-0110	50	31.0	11.0	9.0	34				
							170176		
							170177		
								170178	
SC2-0120	50	31.0	12.0	9.0	34				
SC2-0140	50	31.0	14.0	11.0	34				
SC2-0160	50	31.0	16.0	12.0	34				
SC2-0180	50	31.0	18.0	14.5	34				
SC3-0110	72	48.0	11.0	9.0	45				
SC3-0120	72	48.0	12.0	9.0	45				
SC3-0140	72	48.0	14.0	11.0	45				
SC3-0160	72	48.0	16.0	12.0	45				
SC3-0180	72	48.0	18.0	14.5	45				
SC3-0200	72	48.0	20.0	16.0	45				
SC3-0220	72	48.0	22.0	18.0	45				
SC3-0250	72	48.0	25.0	20.0	45				
SC4-0180	96	60.0	18.0	14.5	68				
SC4-0200	96	60.0	20.0	16.0	68				
SC4-0220	96	60.0	22.0	18.0	68				

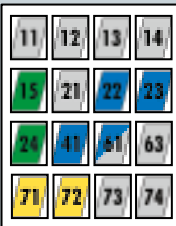

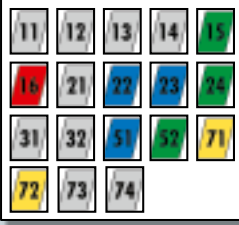



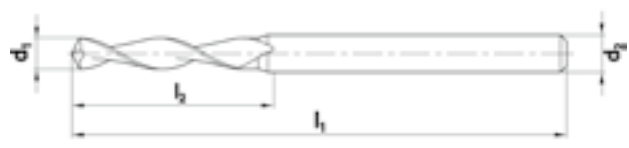

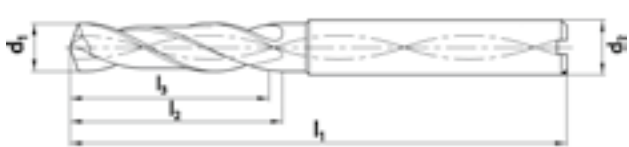













整体硬质合金麻花钻
Solid carbide twist drills



应要求
on request

							F313VS	F285VS	F286VS	
<p>F313VS</p>   <p>F285VS F286VS</p>  							  			
										
$\varnothing d_1$ (h_7)	d_2 (h_6) mm	l_1 mm	l_2 mm			ID				
0.88	3.0	38.0	8.0	2	M 1	158515				
1.08	3.0	38.0	10.0	2	M 1.2	158516				
1.25	3.0	38.0	12.0	2	M 1.4	158517				
1.45	3.0	38.0	12.0	2	M 1.6	158518				
1.65	3.0	38.0	12.0	2	M 1.8	158519				
1.80	3.0	38.0	12.0	2	M 2	158520				
1.95	3.0	38.0	12.0	2	UNC 2-56	158521				
2.30	3.0	38.0	16.0	2	M 2.5	158522				
2.55	3.0	38.0	16.0	2	UNC 4-40	158523				
2.80	3.0	38.0	16.0	2	M 3	158524				
										
$\varnothing d_1$ (m_7)	d_2 (h_6) mm	l_1 mm	l_2 mm	l_3 mm			ID			
3.25	6.0	62.0	20.0	14.0	2	M 3.5	158527			
3.70	6.0	62.0	20.0	14.0	2	M 4	158528			
4.65	6.0	66.0	24.0	17.0	2	M 5	158532			
5.55	6.0	66.0	28.0	20.0	2	M 6	158534			
7.40	8.0	79.0	41.0	29.0	2	M 8	158540			
9.30	10.0	89.0	47.0	35.0	2	M 10	158544			
11.20	12.0	102.0	55.0	40.0	2	M 12	158546			
$\varnothing d_1$ (m_7)	d_2 (h_6) mm	l_1 mm	l_2 mm	l_3 mm			ID			
3.30	6.0	66.0	28.0	23.0	2	M 4	160989			
4.20	6.0	74.0	36.0	29.0	2	M 5	160990			
5.00	6.0	82.0	44.0	35.0	2	M 6	160991			
6.80	8.0	91.0	53.0	43.0	2	M 8	160992			
8.50	10.0	103.0	61.0	49.0	2	M 10	160993			
10.20	12.0	118.0	71.0	56.0	2	M 12	160994			

Boxset		D5855	D5860	D5891
D5855	  N1110-S M3, M4, M5, M6, M8, M10 N1210-S M12	  		
D5860	  N1110-S M3, M4, M5, M6, M8, M10 N1210-S M12   FO DIN 338 D2.5, 3.3, 4.2, 5.0, 6.8, FO DIN 338 8.5, 10.2			
D5891	  N310-3 M3, M4, M5, M6, M8, M10 N410-3 M12			
No D5855 / D5860 / D5891		ID	ID	ID
M3 - M12		118728	118733	170922
Boxset		D5892		
D5892	   N320V-4 M3, M4, M5, M6, M8, M10 			
No D5892		ID		
M3 - M10		170921		
Boxset		D5896		
D5896	   N360V-3 M3, M4, M5, M6, M8, M10 			
No D5896		ID		
M3 - M10		167599		

板牙扳手和丝锥扳手

Die stocks and tap wrenches

<p>D5810- 适用于 DIN EN 22568, DIN EN 24230, DIN EN 24231和 DIN EN 40434 标准圆板牙的板牙扳手 Die stocks for round dies to DIN EN 22568, DIN EN 24230, DIN EN 24231, DIN EN 40434.</p> <p>D5820- 可调整 DIN 1814 标准丝锥扳手 Tap wrenches, adjustable DIN 1814</p>									D5810-	D5820-
										
DIN EN No D5810-	M Ø	MF Ø	UNC Ø	UNF Ø	UNEF UNS UN Ø	W Ø	G (BSP) Ø	NPT NPTF R (BSPT) Ø	ID	
1	16 x 5	1 - 2.6	2 - 2.6	No 1 - 4	No 1 - 4		1/16" - 3/32"		170712	
2	20 x 5	3 - 4	3 - 6	No 5	No 5 - 6		1/8"		170713	
3	20 x 7	4.5 - 6		No 6 - 1/4"	No 8 - 1/4"	No 12 - 1/4"	5/32" - 1/4"		170714	
4	25 x 9	7 - 9	7 - 9	5/16"	5/16"	5/16"	5/16"	1/16"	170715	
5	30 x 11	10 - 11	10 - 11	3/8" - 7/16"	3/8" - 7/16"	3/8" - 7/16"	3/8" - 7/16"	1/8"	170716	
6	38 x 10		12 - 15		1/2" - 9/16"	1/2" - 9/16"		1/4"	170717	
7	38 x 14	12 - 14		1/2" - 9/16"			1/2" - 9/16"	1/4"	170718	
8	45 x 14		16 - 20		5/8" - 3/4"	5/8" - 13/16"		3/8" - 1/2"	170719	
9	45 x 18	16 - 20		5/8" - 3/4"			5/8" - 3/4"	1/2"	170720	
10	55 x 16		22 - 26		7/8" - 1"	7/8" - 1"		5/8" - 3/4"	170721	
11	55 x 22	22 - 24		7/8" - 1"			7/8" - 1"	3/4"	170722	
12	65 x 18		*27 - 36		1 1/8" - 1 3/8"	1 1/16" - 1 3/8"		7/8" - 1"	170723	
13	65 x 25	27 - 36		1 1/8" - 1 3/8"			1 1/8" - 1 3/8"	1"	170724	
14	75 x 20		38 - 42		1 1/2"	1 7/16" - 1 1/2"		1 1/8" - 1 1/4"	170725	
15	75 x 30	39 - 42		1 1/2"			1 1/2" - 1 5/8"		170726	
16	90 x 22		45 - 52			1 3/4" - 2"		1 3/8" - 1 3/4"	170727	
17	90 x 36	45 - 52		1 3/4" - 2"			1 3/4" - 2"		170728	
18	105 x 22		55 - 65				2" - 2 1/4"		170729	
<p>* 3 毫米螺距请使用 13 号 For 3 mm pitches use No. 13.</p>										
No D5820-	a mm								ID	
0	1.9 - 3.0								170730	
1	2.5 - 5.5								170731	
2	4.3 - 8.0								170732	
3	5.5 - 12.0								170733	
4	9.5 - 15.5								170734	
5	12.5 - 22.4								170735	

丝锥加长杆

Tap extension sleeves

D5830- DIN 377 标准丝锥加长杆 Tap extension sleeves ~DIN 377.		D5830-		D5840-									
D5840- 丝锥加长杆 Tap extension sleeves.													
No D5830-	α mm	L_1 mm	D_1 mm	ID									
1	2.10	60	6	110571									
				110572									
2	2.24	70	6	110573									
3	2.40	70	6	110574									
4	2.50	80	7	110575									
5	2.80	90	7	110579									
6	3.00	90	7	110580									
7	3.15	95	7	110581									
8	3.40	95	8	118706									
9	3.55	100	8	118707									
10	3.80	100	9	118708									
11	4.00	105	10	118709									
12	4.30	105	10	118710									
13	4.50	105	10	118711									
14	4.90	110	10	118712									
15	5.00	110	11	118713									
16	5.50	115	12	118714									
17	5.60	110	12	118715									
18	6.20	120	14	118716									
19	6.30	120	14	118717									
20	7.00	125	15	118718									
21	7.10	120	15	118719									
22	7.50	120	15	118720									
23	8.00	125	17	118721									
24	9.00	130	19	110562									
25	10.00	140	21	110563									
26	11.00	150	23	110564									
27	11.20	145	23	110565									
28	12.00	155	25	110566									
29	12.50	160	25	110567									
30	14.00	165	28	110568									
31	14.50	175	29	110569									
32	16.00	180	30	110570									
33	18.00	200	33	110576									
34	20.00	220	36	110577									
35	22.00	220	40	110578									
No D5840-	α mm	L_1 mm	d_2 mm	d_1 mm	D_1 mm	ID							
10	2.70	130	6	3.5	7.5	169928							
11	3.40	130	6	4.5	8.5	169929							
1	4.90	130	6	6.0	12.0	142137							
2	5.50	130	7	7.0	13.0	142138							
3	6.20	130	8	8.0	13.0	142139							
4	7.00	130	9	9.0	17.0	142140							
5	8.00	130	10	10.0	17.0	142141							
6	9.00	130	11	11.0	17.0	142142							
7	9.00	130	12	12.0	20.0	142143							
8	11.00	130	14	14.0	20.0	142144							
9	12.00	130	16	16.0	25.0	142145							

硬度换算表 - HARDNESS CHART

HRC 洛氏硬度 Hardness Rockwell	HB 布氏硬度 Hardness Brinell	HV 维氏硬度 Hardness Vickers	N/mm² Mpa 抗拉强度 Tensile strength
25	253	266	854
26	254	273	873
27	265	279	897
28	272	286	914
29	274	294	944
30	287	302	970
31	295	310	995
32	302	318	1024
33	311	327	1052
34	320	336	1082
35	329	345	1111
36	337	355	1139
37	346	364	1168
38	354	373	1198
39	363	382	1227
40	373	392	1262
41	382	402	1296
42	392	412	1327
43	402	423	1362
44	413	434	1401
45	424	446	1442
46	436	459	1481
47	448	471	1524
48	460	484	1572
49	474	499	1625
50	488	513	1668
51	502	528	1733
52	518	545	1793
53	532	560	1845
54	548	578	1912
55	566	596	1979
56	585	615	2050
57	603	634	2121
58		654	
59		675	
60		698	

DIN 50150 标准硬度换算表

Conversion chart for hardness values, according to DIN 50150

英寸-毫米 - INCHES-MM

Ø" d ₁	Ø mm	TPI UN											W(BSW)	BSF	G (BSP) Rp	Ø mm			
		UNC	UNF	UNEF	4	6	8	12	16	20	28	32							
0 1/16"	1.52 1.59		80											48		28	7.72		
1 2 3/32"	1.85 2.18 2.38	64 56	72 64																
3 4 5 1/8"	2.51 2.84 3.17 3.17 3.50	48 40 40 32	56 48 44 40											40		28	9.72		
5/32" 8 3/16" 10 12	3.96 4.16 4.76 4.82 5.48	32 32 24 24	36 36 32 28											32 24	32				
7/32" 1/4" 9/32" 5/16" 3/8"	5.55 6.35 7.14 7.93 9.52	20 18 16	28 24 24	32 32										24 20 16	28 26 20	19 19	13.15 16.66		
7/16" 1/2" 9/16" 5/8" 11/16"	11.11 12.70 14.28 15.87 17.46	14 13 12 11	20 20 18 18	28 28 24 24					16 16 12					32 32 28 28 32	14 12 12 11	18 16 16 14	14 14	20.95 22.91	
3/4" 13/16" 7/8" 15/16" 1"	19.05 20.64 22.22 23.81 25.40	10 9 8	16 14 12	20 20 20 20				12 12 12						28 28 28 28 32	32 32 32 32	10 9 8	12 12 11	14 14 11	26.44 30.20 33.24
1 1/16" 1 1/8" 1 3/16" 1 1/4" 1 5/16"	26.99 28.57 30.16 31.75 33.34	7 7	12 12	18 18 18			8 8 8 8	12 12 12	16 16 16	20 20 20	28 28 28			7 7	9 9	11 11	37.89 41.91		
1 3/8" 1 7/16" 1 1/2" 1 9/16" 1 5/8"	34.92 36.51 38.10 39.69 41.28	6 6	12 12	18 18 18		6 6	8 8 8	12 12	16 16 16	20 20 20	28 28			6 6 5	8 8	11 11	44.32 47.80		
1 11/16" 1 3/4" 1 13/16" 1 7/8" 1 15/16"	42.86 44.45 46.04 47.63 49.21	5		18		6 6 6 6	8 8 8	12 12 12	16 16 16	20 20 20				5 4 1/2	7	11	53.74		
2" 2 1/8" 2 1/4" 2 3/8" 2 1/2"	50.80 53.97 57.15 60.32 63.50	4 1/2 4 1/2 4				6 6 6 6	8 8 8	12 12 12	16 16 16	20 20 20				4 1/2 4 4	7 6	11 11	59.61 65.71 75.18		
2 5/8" 2 3/4" 2 7/8" 3" 3 1/8"	66.67 69.85 73.02 76.20 79.37	4 4			4 4	6 6 6	8 8 8	12 12 12	16 16 16	20 20 20				3 1/2 3 1/2	6 5	11 11	81.53 87.88		
3 1/4" 3 3/8" 3 1/2" 3 5/8" 3 3/4"	82.55 85.72 88.90 92.07 95.25	4 4 4			4 4	6 6 6	8 8 8	12 12	16 16					3 1/4 3 1/4 3	5 4 1/2	11 11	93.98 100.33 106.68		
3 7/8" 4"	98.42 101.60	4			4	6 6	8 8	12 12	16 16					3	4 1/2	11	113.03		



换算表 - CONVERSION TABLE

	Vc m/min															
	1	2	3	4	5	6	8	10	12	15	20	25	30	40	50	60
	min ⁻¹															
1	318	637	955	1273	1592	1910	2546	3183	3820	4775	6366	7958	9549	12732	15915	19099
2	159	318	477	637	796	955	1273	1592	1910	2387	3183	3979	4775	6366	7958	9549
3	106	212	318	424	531	637	849	1061	1273	1592	2122	2653	3183	4244	5305	6366
4	80	159	239	318	398	477	637	796	955	1194	1592	1989	2387	3183	3979	4775
5	64	127	191	255	318	382	509	637	764	955	1273	1592	1910	2546	3183	3820
6	53	106	159	212	265	318	424	531	637	796	1061	1326	1592	2122	2653	3183
8	40	80	119	159	199	239	318	398	477	597	796	995	1194	1592	1989	2387
10	32	64	95	127	159	191	255	318	382	477	637	796	955	1273	1592	1910
12	27	53	80	106	133	159	212	265	318	398	531	663	796	1061	1326	1592
14	23	45	68	91	114	136	182	227	273	341	455	568	682	909	1137	1364
16	20	40	60	80	99	119	159	199	239	298	398	497	597	796	995	1194
18	18	35	53	71	88	106	141	177	212	265	354	442	531	707	884	1061
20	16	32	48	64	80	95	127	159	191	239	318	398	477	637	796	955
25	13	25	38	51	64	76	102	127	153	191	255	318	382	509	637	764
30	11	21	32	42	53	64	85	106	127	159	212	265	318	424	531	637
35	9	18	27	36	45	55	73	91	109	136	182	227	273	364	455	546
40	8	16	24	32	40	48	64	80	95	119	159	199	239	318	398	477
45	7	14	21	28	35	42	57	71	85	106	141	177	212	283	354	424
50	6	13	19	25	32	38	51	64	76	95	127	159	191	255	318	382

底孔 - CORE HOLES

M DIN 13, ISO 261, *5H / 6H

Ø	P	中心 Ø - Core Ø nut		
d _i	mm	Ø mini	Ø maxi	Ø guide line
* 1	0.25	0.729	0.785	0.75
* 1.1	0.25	0.829	0.885	0.85
* 1.2	0.25	0.929	0.985	0.95
* 1.4	0.30	1.075	1.142	1.10
1.6	0.35	1.221	1.321	1.25
1.7	0.35	1.321	1.421	1.35
1.8	0.35	1.421	1.521	1.45
2	0.40	1.567	1.679	1.60
2.2	0.45	1.713	1.838	1.75
2.3	0.40	1.867	1.979	1.90
2.5	0.45	2.013	2.138	2.05
2.6	0.45	2.113	2.238	2.15
3	0.50	2.459	2.599	2.50
3.5	0.60	2.850	3.010	2.90
4	0.70	3.242	3.422	3.30
4.5	0.75	3.688	3.878	3.75
5	0.80	4.134	4.334	4.20
6	1.00	4.917	5.153	5.00
7	1.00	5.917	6.153	6.00
8	1.25	6.647	6.912	6.80
9	1.25	7.647	7.912	7.80
10	1.50	8.376	8.676	8.50
11	1.50	9.376	9.676	9.50
12	1.75	10.106	10.441	10.20
14	2.00	11.835	12.210	12.00
16	2.00	13.835	14.210	14.00
18	2.50	15.294	15.744	15.50
20	2.50	17.294	17.744	17.50
22	2.50	19.294	19.744	19.50
24	3.00	20.752	21.252	21.00
27	3.00	23.752	24.252	24.00
30	3.50	26.211	26.771	26.50
33	3.50	29.211	29.771	29.50
36	4.00	31.670	32.270	32.00
39	4.00	34.670	35.270	35.00
42	4.50	37.129	37.799	37.50
45	4.50	40.129	40.799	40.50
48	5.00	42.587	43.297	43.00
52	5.00	46.587	47.297	47.00
56	5.50	50.046	50.796	50.50

MF DIN 13, ISO 261, 6H

Ø	P	中心 Ø - Core Ø nut		
d _i	mm	Ø mini	Ø maxi	Ø guide line
8	1.00	6.917	7.153	7.00
9	0.75	8.188	8.378	8.25
9	1.00	7.917	8.153	8.00
10	0.75	9.188	9.378	9.25
10	1.00	8.917	9.153	9.00
10	1.25	8.647	8.912	8.80
11	0.75	10.188	10.378	10.25
11	1.00	9.917	10.153	10.00
12	1.00	10.917	11.153	11.00
12	1.25	10.647	10.912	10.80
12	1.50	10.376	10.676	10.50
14	1.00	12.917	13.153	13.00
14	1.25	12.647	12.912	12.80
14	1.50	12.376	12.676	12.50
15	1.00	13.917	14.153	14.00
15	1.50	13.376	13.676	13.50
16	1.00	14.917	15.153	15.00
16	1.50	14.376	14.676	14.50
17	1.00	15.917	16.153	16.00
17	1.50	15.376	15.676	15.50
18	1.00	16.917	17.153	17.00
18	1.50	16.376	16.676	16.50
18	2.00	15.835	16.210	16.00
20	1.00	18.917	19.153	19.00
20	1.50	18.376	18.676	18.50
20	2.00	17.835	18.210	18.00
22	1.00	20.917	21.153	21.00
22	1.50	20.376	20.676	20.50
22	2.00	19.835	20.210	20.00
24	1.00	22.917	23.153	23.00
24	1.50	22.376	22.676	22.50
24	2.00	21.835	22.210	22.00
25	1.00	23.917	24.153	24.00
25	1.50	23.376	23.676	23.50
25	2.00	22.835	23.210	23.00
27	1.50	25.376	25.676	25.50
27	2.00	24.835	25.210	25.00
28	1.00	26.917	27.153	27.00
28	1.50	26.376	26.676	26.50
28	2.00	25.835	26.210	26.00
30	1.00	28.917	29.153	29.00
30	1.50	28.376	28.676	28.50
30	2.00	27.835	28.210	28.00
32	1.50	30.376	30.676	30.50
32	2.00	29.835	30.210	30.00
33	1.50	31.376	31.676	31.50
33	2.00	30.835	31.210	31.00
35	1.50	33.376	33.676	33.50
36	1.50	34.376	34.676	34.50
36	2.00	33.835	34.210	34.00
36	3.00	32.752	33.252	33.00
39	1.50	37.376	37.676	37.50
39	2.00	36.835	37.210	37.00
39	3.00	35.752	36.252	36.00
40	1.50	38.376	38.676	38.50

MF DIN 13, ISO 261, 6H

Ø	P	中心 Ø - Core Ø nut		
d _i	mm	Ø mini	Ø maxi	Ø guide line
2.5	0.35	2.121	2.221	2.15
3	0.35	2.621	2.721	2.65
3.5	0.35	3.121	3.221	3.15
4	0.50	3.459	3.599	3.50
4.5	0.50	3.959	4.099	4.00
5	0.50	4.459	4.599	4.50
5.5	0.50	4.959	5.099	5.00
6	0.75	5.188	5.378	5.25
7	0.75	6.188	6.378	6.25
8	0.75	7.188	7.378	7.25



底孔 - CORE HOLES

MF DIN 13, ISO 261, 6H

Ø	P	中心 Ø - Core Ø nut		Ø guide line
		Ø mini	Ø maxi	
d ₁	mm	Ø mini	Ø maxi	Ø guide line
40	2.00	37.835	38.210	38.00
40	3.00	36.752	37.252	37.00
42	1.50	40.376	40.676	40.50
42	2.00	39.835	40.210	40.00
42	3.00	38.752	39.252	39.00
45	1.50	43.376	43.676	43.50
45	2.00	42.835	43.210	43.00
45	3.00	41.752	42.252	42.00
48	1.50	46.376	46.676	46.50
48	2.00	45.835	46.210	46.00
48	3.00	44.752	45.252	45.00
50	1.50	48.376	48.676	48.50
50	2.00	47.835	48.210	48.00
50	3.00	46.752	47.252	47.00
52	1.50	50.376	50.676	50.50
52	2.00	49.835	50.210	50.00
52	3.00	48.752	49.252	49.00
55	2.00	52.835	53.210	53.00
60	2.00	57.835	58.210	58.00

MF EN 60423:1994, 7H

Ø	P	中心 Ø - Core Ø nut		Ø guide line
		Ø mini	Ø maxi	
d ₁	mm	Ø mini	Ø maxi	Ø guide line
8	1.00	6.917	7.217	7.00
10	1.00	8.917	9.217	9.00
12	1.50	10.376	10.751	10.50
16	1.50	14.376	14.751	14.50
20	1.50	18.376	18.751	18.50
25	1.50	23.376	23.751	23.50
32	1.50	30.376	30.751	30.50
40	1.50	38.376	38.751	38.50
63	1.50	61.376	61.751	61.50

UNC ANSI B1.1, 2B

Ø"	P	P	中心 Ø - Core Ø nut		Ø guide line
			Ø mini	Ø maxi	
d ₁	TPI	mm	Ø mini	Ø maxi	Ø guide line
1	64	0.397	1.425	1.582	1.45
2	56	0.454	1.695	1.871	1.75
3	48	0.529	1.941	2.146	2.00
4	40	0.635	2.157	2.385	2.25
5	40	0.635	2.487	2.697	2.55
6	32	0.794	2.642	2.895	2.75
8	32	0.794	3.302	3.530	3.40
10	24	1.058	3.683	3.962	3.80
12	24	1.058	4.344	4.597	4.40
1/4"	20	1.270	4.979	5.257	5.10
5/16"	18	1.411	6.401	6.731	6.50

UNC ANSI B1.1, 2B

Ø"	P	P	中心 Ø - Core Ø nut		Ø guide line
			Ø mini	Ø maxi	
d ₁	TPI	mm	Ø mini	Ø maxi	Ø guide line
3/8"	16	1.588	7.798	8.153	8.00
7/16"	14	1.814	9.144	9.550	9.30
1/2"	13	1.954	10.592	11.023	10.80
9/16"	12	2.117	11.989	12.446	12.20
5/8"	11	2.309	13.386	13.868	13.60
3/4"	10	2.540	16.307	16.840	16.60
7/8"	9	2.822	19.177	19.761	19.50
1"	8	3.175	21.971	22.606	22.30
1 1/8"	7	3.629	24.638	25.349	25.00
1 1/4"	7	3.629	27.813	28.524	28.20
1 3/8"	6	4.233	30.353	31.115	30.80
1 1/2"	6	4.233	33.528	34.290	34.00
1 3/4"	5	5.080	38.964	39.827	39.50
2"	4.5	5.644	44.679	45.593	45.30

UNJC ISO 3161:1999, 3B

Ø"	P	P	中心 Ø - Core Ø nut		Ø guide line
			Ø mini	Ø maxi	
d ₁	TPI	mm	Ø mini	Ø maxi	Ø guide line
4	40	0.635	2.228	2.393	2.30
5	40	0.635	2.558	2.723	2.60
6	32	0.794	2.733	2.939	2.80
8	32	0.794	3.393	3.599	3.45
10	24	1.058	3.795	4.064	3.90
12	24	1.058	4.455	4.704	4.55
1/4"	20	1.270	5.113	5.387	5.20
5/16"	18	1.411	6.563	6.833	6.70
3/8"	16	1.588	7.978	8.255	8.10
7/16"	14	1.814	9.347	9.639	9.40
1/2"	13	1.954	10.798	11.095	10.90
9/16"	12	2.117	12.228	12.482	12.40
5/8"	11	2.309	13.627	13.904	13.80
3/4"	10	2.540	16.576	16.881	16.70

底孔 - CORE HOLES

UNF ANSI B1.1, 2B

Ø"	P	P	中心 Ø - Core Ø nut		
d _i	TPI	mm	Ø mini	Ø maxi	Ø guide line
0	80	0.318	1.182	1.305	1.20
1	72	0.353	1.474	1.612	1.50
2	64	0.397	1.756	1.912	1.80
3	56	0.454	2.025	2.197	2.10
4	48	0.529	2.271	2.458	2.35
5	44	0.577	2.551	2.740	2.60
6	40	0.635	2.820	3.022	2.90
8	36	0.706	3.404	3.606	3.50
10	32	0.794	3.963	4.165	4.05
12	28	0.907	4.496	4.724	4.60
1/4"	28	0.907	5.360	5.588	5.50
5/16"	24	1.058	6.782	7.035	6.90
3/8"	24	1.058	8.382	8.636	8.50
7/16"	20	1.270	9.729	10.033	9.80
1/2"	20	1.270	11.329	11.607	11.40
9/16"	18	1.411	12.751	13.081	12.90
5/8"	18	1.411	14.351	14.681	14.50
3/4"	16	1.588	17.323	17.678	17.50
7/8"	14	1.814	20.270	20.675	20.40
1"	12	2.117	23.114	23.571	23.30
1 1/8"	12	2.117	26.289	26.746	26.50
1 1/4"	12	2.117	29.464	29.921	29.70
1 3/8"	12	2.117	32.639	33.096	32.80
1 1/2"	12	2.117	35.814	36.271	36.00

UNEF ANSI B1.1, 2B

Ø"	P	P	中心 Ø - Core Ø nut		
d _i	TPI	mm	Ø mini	Ø maxi	Ø guide line
12	32	0.794	4.623	4.826	4.70
1/4"	32	0.794	5.487	5.689	5.60
5/16"	32	0.794	7.087	7.264	7.20
3/8"	32	0.794	8.662	8.864	8.75
7/16"	28	0.907	10.135	10.337	10.25
1/2"	28	0.907	11.710	11.938	11.85
9/16"	24	1.058	13.132	13.385	13.20
5/8"	24	1.058	14.732	14.986	14.80
11/16"	24	1.058	16.307	16.560	16.40
3/4"	20	1.270	17.679	17.957	17.80
13/16"	20	1.270	19.254	19.558	19.40
7/8"	20	1.270	20.854	21.132	21.00
1"	20	1.270	24.029	24.307	24.10

UN ANSI B1.1, 2B

Ø"	P	P	中心 Ø - Core Ø nut		
d _i	TPI	mm	Ø mini	Ø maxi	Ø guide line
5/16"	20	1.270	6.554	6.858	6.70
3/8"	20	1.270	8.154	8.432	8.30
9/16"	20	1.270	12.904	13.208	13.00
5/8"	20	1.270	14.504	14.782	14.60
1 1/8"	8	3.175	25.146	25.781	25.50
1 1/4"	8	3.175	28.321	28.956	28.70
1 3/8"	8	3.175	31.496	32.131	31.80
1 1/2"	8	3.175	34.671	35.306	35.00
1 5/8"	8	3.175	37.846	38.481	38.20
1 3/4"	8	3.175	41.021	41.656	41.40
1 7/8"	8	3.175	44.196	44.831	44.50
2"	8	3.175	47.371	48.006	47.70
2 1/4"	8	3.175	53.721	54.356	54.10
2 1/2"	8	3.175	60.071	60.706	60.40

UNJF ISO 3161:1999, 3B

Ø"	P	P	中心 Ø - Core Ø nut		
d _i	TPI	mm	Ø mini	Ø maxi	Ø guide line
0	80	0.318	1.217	1.298	1.25
1	72	0.353	1.511	1.603	1.55
2	64	0.397	1.798	1.902	1.85
3	56	0.454	2.073	2.189	2.15
4	48	0.529	2.329	2.466	2.35
5	44	0.577	2.614	2.764	2.70
6	40	0.635	2.888	3.053	2.95
8	36	0.706	3.480	3.663	3.60
10	32	0.794	4.054	4.255	4.10
12	28	0.907	4.602	4.816	4.70
1/4"	28	0.907	5.466	5.662	5.55
5/16"	24	1.058	6.906	7.109	7.00
3/8"	24	1.058	8.494	8.679	8.60
7/16"	20	1.270	9.876	10.084	10.00
1/2"	20	1.270	11.463	11.661	11.55
9/16"	18	1.411	12.913	13.122	13.05
5/8"	18	1.411	14.501	14.702	14.60
3/4"	16	1.588	17.506	17.722	17.60
7/8"	14	1.814	20.460	20.706	20.50
1"	12	2.117	23.340	23.594	23.40



底孔 - CORE HOLES

UNS ANSI B1.1, 2B

Ø"	P	P	中心 Ø - Core Ø nut		
d _i	TPI	mm	Ø mini	Ø maxi	Ø guide line
10	36	0.706	4.064	4.216	4.10
10	40	0.635	4.141	4.292	4.20
10	56	0.454	4.344	4.445	4.40
1/4"	36	0.706	5.588	5.740	5.65
1/4"	40	0.635	5.665	5.816	5.70
1/4"	48	0.529	5.766	5.892	5.80
1/4"	56	0.454	5.868	5.969	5.90
5/16"	36	0.706	7.163	7.340	7.25
3/8"	36	0.706	8.763	8.940	8.80
7/16"	24	1.058	9.957	10.210	10.00
1/2"	24	1.058	11.557	11.811	11.60
1"	14	1.814	23.445	23.825	23.60

W (BSW) BS 84, (DIN11 - 1970)

Ø"	P	P	中心 Ø - Core Ø nut		
d _i	TPI	mm	Ø mini	Ø maxi	Ø guide line
(3/32")	48				1.80
1/8"	40	0.635	2.362	2.591	2.50
(5/32")	32				3.10
3/16"	24	1.058	3.406	3.744	3.60
(7/32")	24				4.40
1/4"	20	1.270	4.724	5.156	4.90
5/16"	18	1.411	6.129	6.588	6.40
3/8"	16	1.588	7.493	7.988	7.70
7/16"	14	1.814	8.791	9.332	9.10
1/2"	12	2.117	9.987	10.589	10.30
5/8"	11	2.309	12.918	13.558	13.30
3/4"	10	2.540	15.799	16.484	16.20
7/8"	9	2.822	18.613	19.355	19.25
1"	8	3.175	21.336	22.149	21.90

G (BSP) DIN ISO 228

Ø"	P	P	中心 Ø - Core Ø nut		
d _i	TPI	mm	Ø mini	Ø maxi	Ø guide line
1/16"	28	0.907	6.561	6.843	6.75
1/8"	28	0.907	8.566	8.848	8.75
1/4"	19	1.337	11.445	11.890	11.60
3/8"	19	1.337	14.950	15.395	15.20
1/2"	14	1.814	18.631	19.172	18.90
5/8"	14	1.814	20.587	21.128	20.90
3/4"	14	1.814	24.117	24.658	24.40
7/8"	14	1.814	27.877	28.418	28.20
1"	11	2.309	30.291	30.931	30.70
1 1/8"	11	2.309	34.939	35.579	35.30
1 1/4"	11	2.309	38.952	39.592	39.30
1 3/8"	11	2.309	41.365	42.005	41.80
1 1/2"	11	2.309	44.845	45.485	45.20
1 3/4"	11	2.309	50.788	51.428	51.20
2"	11	2.309	56.656	57.296	57.00
2 1/4"	11	2.309	62.752	63.392	63.10
2 1/2"	11	2.309	72.226	72.866	72.60
3"	11	2.309	84.926	85.566	85.30

PG DIN 40430

Ø	P	P	中心 Ø - Core Ø nut		
d _i	TPI	mm	Ø mini	Ø maxi	Ø guide line
7	20	1.270	11.28	11.43	11.35
9	18	1.411	13.86	14.01	13.90
11	18	1.411	17.26	17.41	17.30
13.5	18	1.411	19.06	19.21	19.10
16	18	1.411	21.16	21.31	21.20
21	16	1.588	26.78	27.03	26.80
29	16	1.588	35.48	35.73	35.50
36	16	1.588	45.48	45.73	45.50
42	16	1.588	52.48	52.73	52.50
48	16	1.588	57.78	58.03	57.80

TR ISO 2901-2904, DIN 103, 7H

Ø	P	中心 Ø - Core Ø nut		
d _i	mm	Ø mini	Ø maxi	Ø guide line
10	2	8	8.236	8.20
12	3	9	9.315	9.25
14	3	11	11.315	11.25
16	4	12	12.375	12.25
18	4	14	14.375	14.25
20	4	16	16.375	16.25
22	5	17	17.450	17.25
24	5	19	19.450	19.25
26	5	21	21.450	21.25
28	5	23	23.450	23.25
30	6	24	24.500	24.25
32	6	26	26.500	26.25

车削直径 - TURNED DIAMETERS

M DIN 13, ISO 261, *6h / 6g

Ø	P	螺纹外部 Ø - Thread outside Ø		
		Ø mini	Ø maxi	Ø guide line
d ₁	mm			
* 1	0.25	0.933	1.000	0.97
* 1.1	0.25	1.033	1.100	1.07
* 1.2	0.25	1.133	1.200	1.17
* 1.4	0.30	1.325	1.400	1.36
1.6	0.35	1.496	1.581	1.54
1.7	0.35	1.596	1.681	1.64
1.8	0.35	1.696	1.781	1.74
2	0.40	1.886	1.981	1.93
2.2	0.45	2.080	2.180	2.13
2.3	0.40	2.186	2.300	2.23
2.5	0.45	2.380	2.480	2.43
2.6	0.45	2.480	2.600	2.53
3	0.50	2.874	2.980	2.92
3.5	0.60	3.354	3.479	3.41
4	0.70	3.838	3.978	3.91
4.5	0.75	4.338	4.478	4.40
5	0.80	4.826	4.976	4.90
6	1.00	5.794	5.974	5.88
7	1.00	6.794	6.974	6.88
8	1.25	7.760	7.972	7.87
9	1.25	8.760	8.972	8.87
10	1.50	9.732	9.968	9.85
11	1.50	10.732	10.968	10.85
12	1.75	11.701	11.966	11.83
14	2.00	13.682	13.962	13.82
16	2.00	15.682	15.962	15.82
18	2.50	17.623	17.958	17.79
20	2.50	19.623	19.958	19.79
22	2.50	21.623	21.958	21.79
24	3.00	23.577	23.952	23.76
27	3.00	26.577	26.952	26.76
30	3.50	29.522	29.947	29.73
33	3.50	32.522	32.947	32.73
36	4.00	35.465	35.940	35.70
39	4.00	38.465	38.940	38.70
42	4.50	41.437	41.937	41.69
45	4.50	44.437	44.937	44.69
48	5.00	47.399	47.929	47.66
52	5.00	51.399	51.929	51.66
56	5.50	55.365	55.925	55.65

MF DIN 13, ISO 261, 6g

Ø	P	螺纹外部 Ø - Thread outside Ø		
		Ø mini	Ø maxi	Ø guide line
d ₁	mm			
8	1.00	7.794	7.974	7.88
9	0.75	8.838	8.978	8.90
9	1.00	8.794	8.974	8.88
10	0.75	9.838	9.978	9.90
10	1.00	9.794	9.974	9.88
10	1.25	9.760	9.972	9.86
11	0.75	10.838	10.978	10.90
11	1.00	10.794	10.974	10.88
12	1.00	11.794	11.974	11.88
12	1.25	11.760	11.972	11.86
14	1.00	13.794	13.974	13.88
14	1.25	13.760	13.972	13.86
14	1.50	13.732	13.968	13.85
15	1.00	14.794	14.974	14.88
15	1.50	14.732	14.968	14.85
16	1.00	15.794	15.974	15.88
16	1.50	15.732	15.968	15.85
17	1.00	16.794	16.974	16.88
17	1.50	16.732	16.968	16.85
18	1.00	17.794	17.974	17.88
18	1.50	17.732	17.968	17.85
18	2.00	17.682	17.962	17.82
20	1.00	19.794	19.974	19.88
20	1.50	19.732	19.968	19.85
20	2.00	19.682	19.962	19.82
22	1.00	21.794	21.974	21.88
22	1.50	21.732	21.968	21.85
22	2.00	21.682	21.962	21.82
24	1.00	23.794	23.974	23.88
24	1.50	23.732	23.968	23.85
24	2.00	23.682	23.962	23.82
25	1.00	24.794	24.974	24.88
25	1.50	24.732	24.968	24.85
25	2.00	24.682	24.962	24.82
27	1.00	26.794	26.974	26.88
27	1.50	26.732	26.968	26.85
27	2.00	26.682	26.962	26.82
28	1.00	27.794	27.974	27.88
28	1.50	27.732	27.968	27.85
28	2.00	27.682	27.962	27.82
30	1.00	29.794	29.974	29.88
30	1.50	29.732	29.968	29.85
30	2.00	29.682	29.962	29.82
30	3.00	29.577	29.952	29.76
32	1.50	31.732	31.968	31.85
32	2.00	31.682	31.962	31.82
33	1.50	32.732	32.968	32.85
33	2.00	32.682	32.962	32.82
33	3.00	32.577	32.952	32.76
35	1.50	34.732	34.968	34.85
36	1.50	35.732	35.968	35.85
36	2.00	35.682	35.962	35.82
36	3.00	35.577	35.952	35.76
39	1.50	38.732	38.968	38.85
39	2.00	38.682	38.962	38.82
39	3.00	38.577	38.952	38.76

MF DIN 13, ISO 261, 6g

Ø	P	螺纹外部 Ø - Thread outside Ø		
		Ø mini	Ø maxi	Ø guide line
d ₁	mm			
2.5	0.35	2.396	2.481	2.44
3	0.35	2.896	2.981	2.94
3.5	0.35	3.396	3.481	3.44
4	0.50	3.874	3.980	3.93
4.5	0.50	4.374	4.480	4.43
5	0.50	4.874	4.980	4.93
5.5	0.50	5.374	5.480	5.43
6	0.75	5.838	5.978	5.90
7	0.75	6.838	6.978	6.90
8	0.75	7.838	7.978	7.90



车削直径 - TURNED DIAMETERS

MF DIN 13, ISO 261, 6g

Ø	P	螺纹外部 Ø - Thread outside Ø			
d _i	mm	Ø mini	Ø maxi	Ø guide line	
40	1.50	39.732	39.968	39.85	
40	2.00	39.682	39.962	39.82	
40	3.00	39.577	39.952	39.76	
42	1.50	41.732	41.968	41.85	
42	2.00	41.682	41.962	41.82	
42	3.00	41.577	41.952	41.76	
45	1.50	44.732	44.968	44.85	
45	2.00	44.682	44.962	44.82	
45	3.00	44.577	44.952	44.76	
48	1.50	47.732	47.968	47.85	
48	2.00	47.682	47.962	47.82	
48	3.00	47.577	47.952	47.76	
50	1.50	49.732	49.968	49.85	
50	2.00	49.682	49.962	49.82	
50	3.00	49.577	49.952	49.76	
52	1.50	51.732	51.968	51.85	
52	2.00	51.682	51.962	51.82	
52	3.00	51.577	51.952	51.76	
52	4.00	51.465	51.940	51.70	

UNC ANSI B1.1, 2A

Ø"	P	螺纹外部 Ø - Thread outside Ø			
d _i	TPI	mm	Ø mini	Ø maxi	Ø guide line
1	64	0.397	1.743	1.838	1.79
2	56	0.454	2.066	2.169	2.12
3	48	0.529	2.383	2.496	2.44
4	40	0.635	2.695	2.824	2.76
5	40	0.635	3.026	3.154	3.09
6	32	0.794	3.333	3.484	3.41
8	32	0.794	3.991	4.142	4.07
10	24	1.058	4.618	4.800	4.71
12	24	1.058	5.279	5.461	5.37
1/4"	20	1.270	6.117	6.322	6.22
5/16"	18	1.411	7.687	7.907	7.80
3/8"	16	1.588	9.254	9.491	9.37
7/16"	14	1.814	10.816	11.076	10.95
1/2"	13	1.954	12.386	12.661	12.52
9/16"	12	2.117	13.958	14.246	14.10
5/8"	11	2.309	15.528	15.834	15.68
3/4"	10	2.540	18.677	19.004	18.84
7/8"	9	2.822	21.824	22.176	22.00
1"	8	3.175	24.969	25.349	25.16
1 1/8"	7	3.629	28.103	28.519	28.31
1 1/4"	7	3.629	31.278	31.694	31.49
1 3/8"	6	4.233	34.402	34.864	34.63
1 1/2"	6	4.233	37.577	38.039	37.81
1 3/4"	5	5.080	43.860	44.381	44.12
2"	4.5	5.644	50.168	50.726	50.45
2 1/4"	4.5	5.644	56.518	57.076	56.80
2 1/2"	4	6.350	62.817	63.421	63.12
2 3/4"	4	6.350	69.165	69.768	69.47
3"	4	6.350	75.515	76.118	75.82
3 1/4"	4	6.350	81.862	82.466	82.16
3 1/2"	4	6.350	88.212	88.816	88.51

UNC ANSI B1.1, 2A

Ø"	P	螺纹外部 Ø - Thread outside Ø			
d _i	TPI	mm	Ø mini	Ø maxi	Ø guide line
3 3/4"	4	6.350	94.560	95.163	94.86
4"	4	6.350	100.910	101.513	101.21

UNF ANSI B1.1, 2A

Ø"	P	螺纹外部 Ø - Thread outside Ø			
d _i	TPI	mm	Ø mini	Ø maxi	Ø guide line
0	80	0.318	1.431	1.511	1.47
1	72	0.353	1.751	1.838	1.79
2	64	0.397	2.073	2.169	2.12
3	56	0.454	2.393	2.496	2.44
4	48	0.529	2.713	2.827	2.77
5	44	0.577	3.036	3.157	3.10
6	40	0.635	3.356	3.484	3.42
8	36	0.706	4.006	4.145	4.08
10	32	0.794	4.651	4.803	4.73
12	28	0.907	5.296	5.461	5.38
1/4"	28	0.907	6.160	6.324	6.24
5/16"	24	1.058	7.727	7.909	7.82
3/8"	24	1.058	9.315	9.497	9.41
7/16"	20	1.270	10.874	11.079	10.98
1/2"	20	1.270	12.462	12.666	12.56
9/16"	18	1.411	14.031	14.251	14.14
5/8"	18	1.411	15.619	15.839	15.73
3/4"	16	1.588	18.774	19.011	18.89
7/8"	14	1.814	21.923	22.184	22.05
1"	12	2.117	25.065	25.354	25.21
1 1/8"	12	2.117	28.240	28.529	28.38
1 1/4"	12	2.117	31.415	31.704	31.56
1 3/8"	12	2.117	34.588	34.876	34.73
1 1/2"	12	2.117	37.763	38.051	37.91

UNEF ANSI B1.1, 2A

Ø"	P	螺纹外部 Ø - Thread outside Ø			
d _i	TPI	mm	Ø mini	Ø maxi	Ø guide line
12	32	0.794	5.312	5.463	5.39
1/4"	32	0.794	6.173	6.324	6.25
5/16"	32	0.794	7.760	7.912	7.84
3/8"	32	0.794	9.348	9.499	9.42
7/16"	28	0.907	10.920	11.084	11.00
1/2"	28	0.907	12.507	12.672	12.59
9/16"	24	1.058	14.075	14.257	14.17
5/8"	24	1.058	15.662	15.844	15.75
11/16"	24	1.058	17.250	17.432	17.34
3/4"	20	1.270	18.812	19.016	18.91
13/16"	20	1.270	20.339	20.604	20.50
7/8"	20	1.270	21.987	22.191	22.09
15/16"	20	1.270	23.572	23.776	23.67
1"	20	1.270	25.159	25.364	25.26
1 1/8"	18	1.411	28.319	28.539	28.43
1 1/4"	18	1.411	31.491	31.711	31.60
1 1/2"	18	1.411	37.841	38.061	37.95

车削直径 - TURNED DIAMETERS

UN ANSI B1.1, 2A

Ø"	P	P	P 螺纹外部 Ø - Thread outside Ø		
d _i	TPI	mm	Ø mini	Ø maxi	Ø guide line
5/16"	20	1.270	7.702	7.907	7.80
3/8"	20	1.270	9.289	9.494	9.39
9/16"	20	1.270	14.049	14.254	14.15
5/8"	20	1.270	15.637	15.841	15.74
1 1/8"	8	3.175	28.141	28.521	28.33
1 1/4"	8	3.175	31.316	31.696	31.51
1 3/8"	8	3.175	34.489	34.869	34.68
1 1/2"	8	3.175	37.664	38.044	37.85
1 5/8"	8	3.175	40.839	41.219	41.03
1 3/4"	8	3.175	44.011	44.391	44.20
1 7/8"	8	3.175	47.186	47.566	47.38
2"	8	3.175	50.361	50.741	50.55
2 1/4"	8	3.175	56.709	57.089	56.90
2 1/2"	8	3.175	63.059	63.439	63.25
2 3/4"	8	3.175	69.406	69.786	69.60
3"	8	3.175	75.753	76.133	75.94

W (BSW) BS 84

Ø"	P	P	P 螺纹外部 Ø - Thread outside Ø		
d _i	TPI	mm	Ø mini	Ø maxi	Ø guide line
1/4"	20	1.270	6.165	6.319	6.24
5/16"	18	1.411	7.737	7.904	7.82
3/8"	16	1.588	9.312	9.489	9.40
7/16"	14	1.814	10.884	11.074	10.98
1/2"	12	2.117	12.456	12.662	12.56
5/8"	11	2.309	15.613	15.832	15.72
3/4"	10	2.540	18.771	19.004	18.89
7/8"	9	2.822	21.979	22.225	22.10
1"	8	3.175	25.138	25.400	25.27
1 1/8"	7	3.629	28.296	28.575	28.44
1 1/4"	7	3.629	31.465	31.750	31.61
1 1/2"	6	4.233	37.793	38.100	37.95
1 3/4"	5	5.080	44.117	44.450	44.28
2"	4.5	5.644	50.449	50.800	50.62
2 1/4"	4	6.350	56.779	57.150	56.96
2 1/2"	4	6.350	63.119	63.500	63.31

UNS ANSI B1.1, 2A

Ø"	P	P	P 螺纹外部 Ø - Thread outside Ø		
d _i	TPI	mm	Ø mini	Ø maxi	Ø guide line
10	36	0.706	4.664	4.803	4.73
10	40	0.635	4.674	4.803	4.74
10	56	0.454	4.705	4.808	4.76
1/4"	36	0.706	6.188	6.327	6.26
1/4"	40	0.635	6.198	6.327	6.26
1/4"	48	0.529	6.216	6.329	6.27
1/4"	56	0.454	6.226	6.329	6.28
5/16"	36	0.706	7.775	7.914	7.84
3/8"	36	0.706	9.360	9.499	9.43
7/16"	24	1.058	10.902	11.084	10.99
1/2"	24	1.058	12.487	12.669	12.58
1"	14	1.814	25.096	25.356	25.23

PG DIN 40430

Ø	P	P	P 螺纹外部 Ø - Thread outside Ø		
d _i	TPI	mm	Ø mini	Ø maxi	Ø guide line
7	20	1.270	12.3	12.5	12.40
9	18	1.411	15.0	15.2	15.10
11	18	1.411	18.4	18.6	18.50
13.5	18	1.411	20.2	20.4	20.30
16	18	1.411	22.3	22.5	22.40
21	16	1.588	28.0	28.3	28.15
29	16	1.588	36.7	37.0	36.85
36	16	1.588	46.7	47.0	46.85
42	16	1.588	53.7	54.0	53.85
48	16	1.588	59.0	59.3	59.15

G (BSP) DIN ISO 228

Ø"	P	P	P 螺纹外部 Ø - Thread outside Ø		
d _i	TPI	mm	Ø mini	Ø maxi	Ø guide line
1/16"	28	0.907	7.509	7.723	7.62
1/8"	28	0.907	9.514	9.728	9.62
1/4"	19	1.337	12.907	13.157	13.03
3/8"	19	1.337	16.412	16.662	16.54
1/2"	14	1.814	20.671	20.955	20.81
5/8"	14	1.814	22.627	22.911	22.77
3/4"	14	1.814	26.157	26.441	26.30
7/8"	14	1.814	29.917	30.201	30.06
1"	11	2.309	32.889	33.249	33.07
1 1/8"	11	2.309	37.537	37.897	37.72
1 1/4"	11	2.309	41.550	40.910	41.73
1 3/8"	11	2.309	43.963	44.323	44.14
1 1/2"	11	2.309	47.443	47.803	47.62
1 3/4"	11	2.309	53.386	53.746	53.57
2"	11	2.309	59.254	59.614	59.43
2 1/4"	11	2.309	65.276	65.710	65.49
2 1/2"	11	2.309	74.750	75.184	74.97
2 3/4"	11	2.309	81.100	81.534	81.32
3"	11	2.309	87.450	87.884	87.67
3 1/2"	11	2.309	99.896	100.330	100.11

TR ISO 2901-2904, DIN 103, 7e

Ø	P	P 螺纹外部 Ø - Thread outside Ø		
d _i	mm	Ø mini	Ø maxi	Ø guide line
10	2	9.820	10.000	9.91
12	3	11.764	12.000	11.88
14	3	13.764	14.000	13.88
16	4	15.700	16.000	15.85
18	4	17.700	18.000	17.85
20	4	19.700	20.000	19.85
22	5	21.665	22.000	21.83
24	5	23.665	24.000	23.83
26	5	25.665	26.000	25.83
28	5	27.665	28.000	27.83
30	6	29.625	30.000	29.81
32	6	31.625	32.000	31.81



技术调查表

螺纹切削和螺纹挤压

咨询 <input type="checkbox"/>	测试结果 <input type="checkbox"/>	投诉 <input type="checkbox"/>
代理商: _____	联系人: _____	
客户名: _____	电子邮件: _____	
电话或传真: _____	日期: _____	
<hr/>		
1. 工具类型: _____	螺纹尺寸: _____	
工具特点: _____	公差: _____	
<hr/>		
2. 材料分组: _____		
材料号码: _____	硬度: _____	N/mm ² / HB / HRC
标准: _____	延伸率: _____	%
<hr/>		
3. 螺纹: <input type="checkbox"/> 盲孔 <input type="checkbox"/> 通孔	螺纹长度: _____ 毫米	
底孔 Ø: _____	深度: _____	毫米
镗孔 Ø: _____	深度: _____	毫米
<hr/>		
4. 切割速度 (V _c): _____ m/min	_____ l/min	
进给 (f): _____ %		
<hr/>		
5. 机床: _____	<input type="checkbox"/> 内部冷却	
加工方向: <input type="checkbox"/> 水平切割 <input type="checkbox"/> 垂直切割		
刚性攻丝: <input type="checkbox"/> "Soft Rigid Tapping"	丝锥夹柄: <input type="checkbox"/> 轴向补偿	
<input type="checkbox"/> 弹簧夹头	<input type="checkbox"/> 可离合	
<input type="checkbox"/> Weldon	<input type="checkbox"/> 可逆式	
<input type="checkbox"/> 冷 / 热胀柄	<input type="checkbox"/> 过载离合器	
<hr/>		
6. 润滑: <input type="checkbox"/> 乳化液 <input type="checkbox"/> 切削油 <input type="checkbox"/> 空气 <input type="checkbox"/> 少量润滑		
润滑产品: _____		
<hr/>		
7. 刀具更换原因: <input type="checkbox"/> 刀具磨损 <input type="checkbox"/> 刀具断裂		
<input type="checkbox"/> 螺纹牙型不正确 (螺纹量规检查结果)	<input type="checkbox"/> 刀具倒角部分断裂	
<input type="checkbox"/> 机床发生错误	<input type="checkbox"/> 刀具导向部分断裂	
<hr/>		
8. 效率比较		
测试刀具: _____		
性能观测结果: _____		
<hr/>		
备注: _____		
<hr/>		

TECHNICAL QUESTIONNAIRE

THREAD CUTTING AND THREAD FORMING

Inquiry

Test result

Complaint

Agency : _____
Customer : _____
Phone or fax : _____

Contact : _____
E-mail : _____
Date : _____

1. Tool type : _____ Thread size : _____
Particularity : _____ Class of tolerance : _____

2. Material group : _____
Material N° : _____ Hardness : _____ N/mm² /HB/HRC
Norm : _____ Elongation : _____ %

3. Thread : blind hole through hole Threaded length : _____ mm
Core hole Ø : _____ Depth : _____ mm
Counter-bore Ø : _____ Depth : _____ mm

4. Cutting speed (V_c) : _____ m/min _____ l/min
Feed (f) : _____ %

5. Machine : _____ internal coolant
Working position : horizontal vertical
Rigid Tapping : "Soft Rigid Tapping"
 collet de-clutching
 Weldon reversible
 hot / cold shrunk sliding clutch

6. Lubricant : emulsion oil air mist
Product : _____

7. Tool change reason : tool wear tool breakage
 thread not correct (checked with thread plug gauge) tooth breakage in the chamfer lead
 machine error tooth breakage in the guiding thread

8. Efficiency comparison

Tool under test : _____
Performance and observations : _____

Remarks : _____

技术调查表

螺纹铣削和螺纹旋风铣削

咨询 <input type="checkbox"/>	测试结果 <input type="checkbox"/>	投诉 <input type="checkbox"/>
代理商: _____	联系人: _____	
客户名: _____	电子邮件: _____	
电话或传真: _____	日期: _____	
<hr/>		
1. 工具类型: _____		
工具 \emptyset : _____	螺距: _____	
系列: _____	涂层: _____	
<hr/>		
2. 材料分组: _____		
材料号码: _____	硬度: _____	N/mm ² / HB / HRC
标准: _____	延伸率: _____	%
<hr/>		
3. 螺纹: <input type="checkbox"/> 内螺纹 <input type="checkbox"/> 外螺纹 洞型: <input type="checkbox"/> 盲孔 <input type="checkbox"/> 通孔		
螺纹长度: _____	毫米	
底孔 \emptyset : _____	深度: _____	毫米
镗孔 \emptyset : _____	深度: _____	毫米
<hr/>		
4. 切割速度 (V_c): _____ m/min _____ l/min		
进给 (f): _____	mm/圈	进给 (f_z): _____ mm/齿
<hr/>		
5. 机床: _____ <input type="checkbox"/> 内部冷却		
加工方向: <input type="checkbox"/> 水平切割	工具附件: <input type="checkbox"/> 弹簧夹头	<input type="checkbox"/> Weldon / 哨形凹槽柄
<input type="checkbox"/> 垂直切割	<input type="checkbox"/> 液压膨胀夹头	<input type="checkbox"/> 冷 / 热涨柄
<hr/>		
6. 润滑: <input type="checkbox"/> 乳化液 <input type="checkbox"/> 切削油 <input type="checkbox"/> 空气 <input type="checkbox"/> 少量润滑		
润滑产品: _____		
<hr/>		
7. 刀具更换原因 <input type="checkbox"/> 刀具磨损 <input type="checkbox"/> 刀具断裂		
<input type="checkbox"/> 螺纹牙型不正确 (螺纹量规检查结果)		<input type="checkbox"/> 编程错误
<hr/>		
8. 效率比较		
测试刀具: _____		
性能观测结果: _____		
<hr/>		
备注: _____		

TECHNICAL QUESTIONNAIRE

THREAD MILLING AND THREAD WHIRLING

Inquiry

Test result

Complaint

Agency : _____
Customer : _____
Phone or fax : _____

Contact : _____
E-mail : _____
Date : _____

1. Tool type : _____

Tool Ø : _____
Serie : _____

Pitch : _____
Coating : _____

2. Material group : _____

Material N° : _____
Norm : _____

Hardness : _____ N/mm² /HB/HRC
Elongation : _____ %

3. Thread : internal external

Hole : blind through

Threaded length : _____ mm

Core hole Ø : _____ Depth : _____ mm

Counter-bore Ø : _____ Depth : _____ mm

4. Cutting speed (V_c) : _____ m/min _____ 1/min

Feed (f) : _____ mm/rev. **Feed (f_z) :** _____ mm/tooth

5. Machine : _____ internal coolant

Working position : horizontal
 vertical

Tool attachment : collet
 hydraulic chuck

Weldon / Whistle Notch
 hot / cold shrunk

6. Lubricant : emulsion

oil

air

mist

Product : _____

7. Tool change reason : tool wear

tool breakage

incorrect threading (inspected with gauge)

programme error

8. Efficiency comparison

Tool under test : _____

Performance and observations : _____

Remarks : _____

送货和缴款条件

订单	不能从货存里提取的产品会被告知。已经不属于任何标准产品系列但任然出现在产品目录上的商品，会以特制商品标准收费。取消订单必须要双方书面同意。
报价和订货确认	因为螺纹加工产业的持续发展，报价表上所有的产品描述，附录，重量数据，尺寸，画图，图标只供参考。只有带特殊注释的技术参数才有约束力。
价格	目录上的价格不包含消费税，包装，保险，运费（从瑞士 Malleray 工厂发货），海关和法定税务。如果价格改变，我们有权在已确认订单上增加收费。
付款	买家必须提前付款，或通过瑞士银行向我们开立不可撤销和保兑的跟单信用证。全部的银行手续费用由买家承担。
所有权	在产品售价和附带费用全部付款之前，我们保留产品的所有权。
发送	交货时风险转由买方承担。
发货	确认交货日期没有约束力。我们会尽量按时交货。但是我们不承担因发货迟到直接和间接造成的损失。
特殊订单	对于特制刀具，卖方有权多供或短供订货量的15%，少量订单时多供或少供一两件。
质量保证	所有被 DC 认证为有缺陷的产品将会被免费更换。
投诉	收货后十五天以内提出的投诉才会被受理。
图标和草图	禁止向第三方复制和传递目录上的画图和其他文件。目录上的草图只供参考使用，不被约束。
特殊条件	如果出现部分或整体生产中断，我们保留取消部分或全部发货的权利。
管辖法院	所有争端受瑞士法律约束，由 Moutier （瑞士）法院审理。

DELIVERY AND PAYMENT CONDITIONS

Orders	Orders, which cannot be delivered from stock, will be acknowledged. Items, which do not belong any more to our standard programme, although still featured in the catalogue, will be invoiced as «specials». Orders may only be cancelled by mutual written agreement.
Quotations and acknowledgements	For reasons of constant development in this field, all descriptions mentioned in our quotations, annexed documents, weight indications, measurements as well as illustrations and drawings are approximate indications. These technical data have binding value only if expressly specified.
Prices	Our prices are quoted for deliveries ex works Malleray, excluding VAT, packing, insurance, freight, customs' and legalisation duties. Should prices increase, we reserve the right to invoice tools already acknowledged at the new prices.
Payment	Payments must be made in advance or against irrevocable and confirmed documentary credit to be opened in our favour with a Swiss bank. All banking commissions and charges have to be borne by the buyer.
Right of ownership	We reserve the right of ownership of all goods supplied until the sales price, plus all incidental charges, have fully been paid.
Despatch	Deliveries take place at the purchaser's risk.
Delivery	Confirmed delivery dates are non-binding. We will do our utmost to maintain them. However, we cannot accept responsibility of direct or consequential losses due to delayed deliveries.
Special orders	For all special tools we reserve the right to over or under supply the ordered quantity by up to 15 %, or on small quantities by 1 or 2 pieces.
Guarantee	Tools recognised to be defective by DC will be replaced free of charge, but without prejudice.
Complaints	Complaints will be considered only within 15 days after receipt of the goods.
Drawings and sketches	The reproduction or transmission of drawings and other documents to a third party are prohibited. The information (drawings and prints) in our catalogue is for guidance only and is not binding.
Special conditions	In the case of partial or total disruption of our production; we reserve the right to partially or totally cancel our delivery commitments.
Tribunal	All disputes are subject to Swiss Law. The seat of court of law will be Moutier (Switzerland).

附加费用 - PRICE SUPPLEMENTS

表面处理 and 改造无涂层刀具的附加费用

	每件商品总价上附加	按类型和大小 准备成本分担 (净价)
切削角度修改 (Ø 5 - 20 mm)	10 %	按要求
加长倒角 (bis Ø 20 mm)	10 %	按要求
减短倒角 (Ø 3 - 20 mm)	20 %	按要求
切割口修磨 (Ø 5 - 20 mm)	10 %	按要求
移除刃角	3 %	按要求
从Ø 4毫米起螺纹截短	12 %	按要求
离子氮化 + "V" 表面处理	10 %	按要求
DC "V" 表面处理	8 %	按要求
附加打标	5 %	按要求
中心内部冷却	按要求	按要求
内部冷却, 径向出口	按要求	按要求
TiN, TiCN, VS, CrN, HL 涂层	按要求	按要求

Price supplements for modifications for bright finished taps and surface treatments

	On gross price each	Participation of set-up costs per type and size (net)
Modification of cutting angle (Ø 5 - 20 mm)	10 %	on request
Lengthening of chamfer (up to Ø 20 mm)	10 %	on request
Shortening of chamfer (Ø 3 - 20 mm)	20 %	on request
Grinding of peeling cut (Ø 5 - 20 mm)	10 %	on request
Removal of centre point	3 %	on request
Truncated thread from Ø 4 mm	12 %	on request
NV-Plasma nitriding + "V" surface treatment	10 %	on request
DC "V" surface treatment	8 %	on request
Additional marking	5 %	on request
Internal coolant, with frontal outflow	on request	on request
Internal coolant, with radial outflow	on request	on request
Coatings TiN, TiCN, VS, CrN, HL	on request	on request

量规证书价格 - Prices for gauge test certificates

新订购螺纹量规 / 测量不确定度 U95

For new ordered thread gauges / Measuring uncertainty U95

		净价 / Net prices	
D5703	D5725	Ø 1 - 2.9 mm	按要求 / on request
		Ø 3 - 40 mm	按要求 / on request
D5701-1	D5701-2	Ø 1 - 2.9 mm	按要求 / on request
		Ø 3 - 40 mm	按要求 / on request
		Ø 41 - 80 mm	按要求 / on request
		Ø 81 - 200 mm	按要求 / on request
D5704	D5714	Ø 1 - 2.9 mm	按要求 / on request
		Ø 3 - 40 mm	按要求 / on request
		Ø 41 - 80 mm	按要求 / on request
		Ø 81 - 200 mm	按要求 / on request
D5720 / D5721	D5722 / D5723	Ø 3 - 40 mm	按要求 / on request
		Ø 41 - 80 mm	按要求 / on request
		Ø > 80 mm	按要求 / on request

所有‘被认证’的量规会被印上与校检证书相应的编号。

All "certified" gauges will be marked with the identity number of the corresponding test certificate.

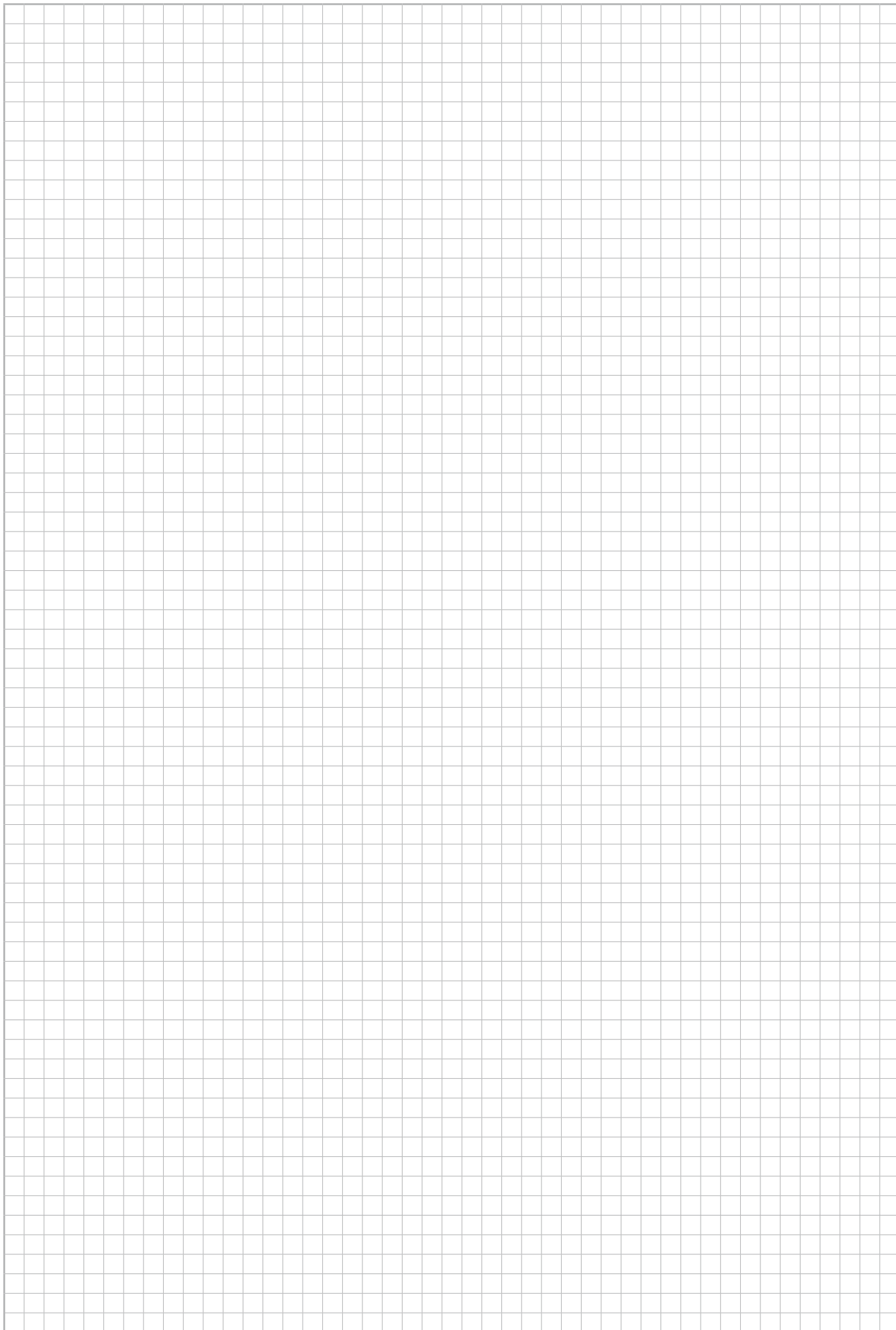



DC SWISS SA

CH-2735 Malleray

Tel. +41 32 491 63 63

Fax +41 32 491 64 64

E-mail: info@dcswiss.ch

DC SWISS GmbH

Graseggerstraße 125
DE-50737 Köln
Tel. +49 221 995 532-0
Fax +49 221 995 532-10
E-Mail: info@dcswiss.de

DC SWISS s.r.l.

Via Canova 10
IT-20017 Rho
Tel. +39 02 669 40 41
Fax +39 02 669 78 50
E-mail: info@dcswiss.it

DC SWISS UK Ltd

9 Orgreave Road
UK-Sheffield S13 9LQ
Tel. +44 114 2939013
Fax +44 114 2880936
E-mail: info@dcswiss.co.uk

警告

技术故障或者疏漏可能会导致加工刀具的断裂和碎裂，并危及操作员的安全和健康，因此操作员要严格按照安全操作规程进行操作，并且一定要带佩护目镜。螺纹刀具的磨削加工会产生有害物质，因此必须严格按照最安全的操作标准执行该工作。

Warning

Thread tools can break or shatter either through technical failure or negligence, and can endanger the health of the operator. Always obey the safety and health regulations, also the wearing of safety glasses is compulsory.

The grinding of threading tools causes hazardous particles, and must be performed only under most rigorous safety standards.

我们已尽全力保证本资料内容（图纸、印刷品、技术资料）正确无误。但是我们不为由于疏漏以及随后修改所引发的错误承担责任。

禁止向第三方复制和传递图纸以及其他相关资料内容。

We have made every effort to ensure that the information (drawings, prints, technical data) given is correct. However, we do not assume any responsibility for any errors, omissions or subsequent changes.

The reproduction of drawings and other documents and their transmission to a third party is prohibited.

