

Atlas Industrial Flat Panel PC Monitors

ATM1500/ATM1500T

The **Atlas** ATM1500/ATM1500T is a high performance 15" color TFT flat panel monitor specifically designed for harsh industrial environments including Class I Division 2, Class II Division 2 and Class III Hazardous Locations. The ATM1500/ATM1500T accepts standard analog VGA or digital DVI input and can display all VESA video modes up to 1280 x 1024 at 75Hz, 800:1 contrast with 16 million colors. An optional 5-wire analog touch screen (ATM1500T) is available that offers both RS-232 and USB interface capability. The monitor is housed in a heavy duty steel chassis with a powder coated machined aluminum bezel. The monitor is certified to NEMA 4/4X/12 standards, is UL/CUL listed, meets CE requirements and is RoHS compliant. Panel mounting is simplified using convenient mounting clips instead of conventional studs. All monitors are shipped with a power input wiring receptacle, 6' VGA cable, 6' RS-232 cable (ATM1500T only), 2m USB Cable (ATM1500T only), mounting hardware, Quick Installation Guide, and CD-ROM containing Hardware User's Guide (ATM-15-USER) and touch screen driver software for Windows*.

*Visit automationdirect.com for specific operating system requirements.



\$1,030.00 / \$1,237.00



Specifications

- 15" color TFT LCD display
- UL 508 and ANSI/ISA 12.12.01-2012 listed for Hazardous Locations: Class I, Division 2, Groups A, B, C, D; Class II, Division 2, Groups F and G and Class III hazardous locations when mounted in a NEMA Type 1, 4, 4X or 12 enclosure
- NEMA 4/4X/12 front bezel
- 2-year warranty
- RoHS compliant
- Integral 100-240 VAC power supply
- Simplified installation with no studs
- Thin design - only 2.4" behind bezel
- Accepts analog 15-pin Video input, digital input DVI-D
- VESA compliant - all modes up to SXGA, 16 million colors
- Optional 5-wire resistive touch screen with both RS-232 and USB interface

Dimensions

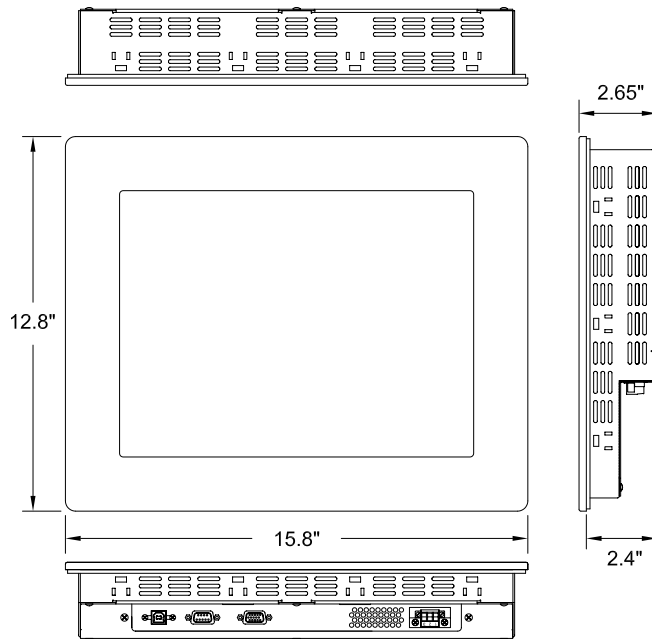

NOTE: Don't forget the optional cables shown on the Accessories page.

Mounting Cutout

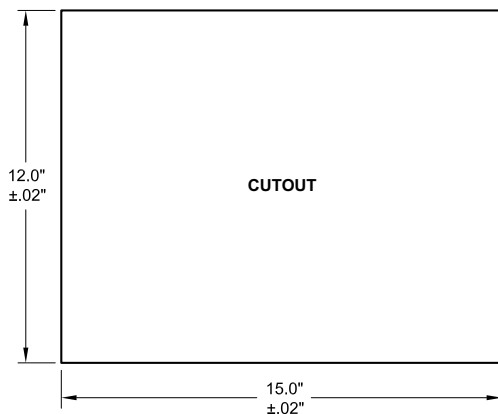

Cable Connections

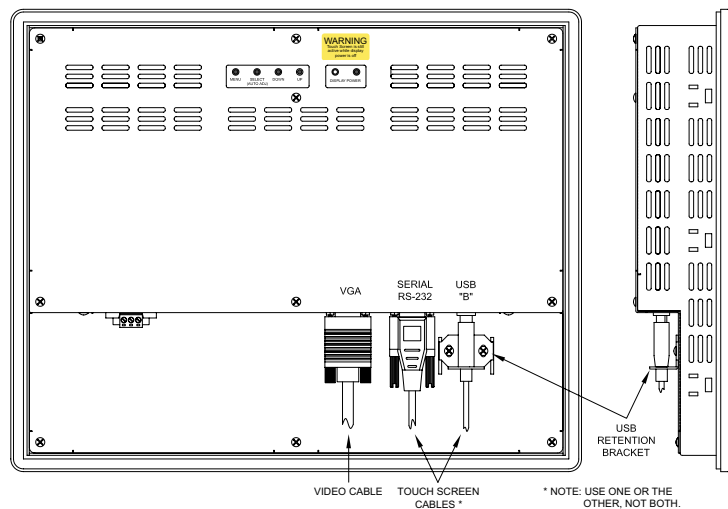

Atlas Industrial Flat Panel PC Monitors

LCD Monitor Specifications



LCD Monitor Specifications						
Part Numbers	ATM1500	ATM1500T	ATM1700	ATM1700T	ATM1900	ATM1900T
Nominal Size	15"		17"		19"	
Price	\$1,030.00	\$1,237.00	\$1,299.00	\$1,506.00	\$1,610.00	\$1,817.00
DISPLAY						
Display Type	TFT Active Matrix					
Display Diagonal Size	14.96" (380 mm)		17.04" (432.8 mm)		18.97" (481.8 mm)	
Display Size (Active Area H x W)	8.98" x 11.97" (228.1 mm x 304.0 mm)		10.64" x 13.30" (270.3 mm x 337.8 mm)		11.85" x 14.82" (301.0 mm x 376.4 mm)	
Native Resolution	XGA, 1024 x 768		SXGA, 1280 x 1024			
VESA Modes Supported	Up to 1280 x 1024 @75Hz					
Displayable Colors	16M					
Brightness, Typical	250 Nit		300 Nit		270 Nit	
Contrast Ratio, Typical	800:1		1000:1		2000:1	
Horizontal/Vertical View Angle, CR>5, Typical	150°/145°		170°/170°		178°/178°	
Backlight Life	50,000 hrs, Minimum					
Display Input Signal	Analog 15-Pin D-Sub, DVI-D					
Impact Window	0.125" (3.2 mm) Lexan (polycarbonate), clear hard coat					
PHYSICAL						
Overall Monitor Dimensions (H x W x D)	12.80" x 15.80" x 2.65" (325.1 mm x 401.3 mm x 67.3 mm)		14.48" x 17.14" x 2.85" (367.8 mm x 435.4 mm x 72.4 mm)		15.70" x 18.66" x 2.95" (398.8 mm x 474.0 mm x 74.9 mm)	
Cutout Dimensions (H x W)	12.00" x 15.00" (304.8 mm x 381.0 mm)		13.70" x 16.35" (348.0 mm x 415.3 mm)		14.90" x 17.75" (378.5 mm x 450.9 mm)	
Chassis Depth	2.4" (61.0 mm)		2.6" (66.0 mm)		2.7" (68.6 mm)	
Bezel Construction	0.25" (6.4 mm) Machined Aluminum with recessed gasket pocket					
Bezel Finish	Dark Gray Textured Powder Coated					
Chassis Construction	16 Gauge RoHS Compliant CRS Steel					
Weight	14.0 lbs (6.4 kg)		18.5 lbs (8.4 kg)		21 lbs (9.5 kg)	
Shipping Weight	19 lbs (8.6 kg)		23.5 lbs (10.7 kg)		26 lbs (11.8 kg)	
ELECTRICAL						
AC Input Voltage	100 - 240 VAC, 50/60 Hz					
AC Input Current	0.5A Maximum		1A Maximum			
Input Power	≤ 25W		≤ 30W		≤ 35 W	
ENVIRONMENTAL						
Operating Temperature	0 to 50 °C (32 to 122 °F)					
Storage Temperature	-20 to 60 °C (-4 to 140 °F)					
Operating and Storage Humidity	20% to 80% RH, noncondensing					
Operating Shock	15g peak acceleration, 11msec					
Operating Vibration 5-2000 Hz	0.006" peak to peak, 1g max					
Operating Altitude	Sea level - 10,000 feet					
Storage Altitude	Sea level - 40,000 feet					
AGENCY						
Front Panel NEMA Rating	NEMA 4/4X/12, IP65					
FCC	47 CFR, Part 15, Class A					
EU CE Marking Compliance	CE, EN 55022: Class A, EN 61000-3-2: Class A, EN 61000-3-3, EN 61000-6-2, IEC 60950-1, RoHS compliant					
Safety Agency Approvals	UL 508 Listed (file #E157382), ANSI/ISA 12.12.01-2012 Listed* (file #E200031), cUL Listed CSA C22.2, #142, CSA C22.2, #143*					
* Suitable for use in Class I, Division 2, Groups A, B, C and D, Class II, Division 2, Groups F and G, Class III Hazardous Locations or Non-Hazardous locations only.						
For use on a flat surface of a type 1, 4, 4X or 12 enclosure with provisions for Class I Division 2 wiring methods						
Temperature Code: T5						

Atlas Industrial Flat Panel PC Monitors

LCD Monitor Specifications (cont'd)

Touch Screen Specifications			
Part Numbers	ATM1500T	ATM1700T	ATM1900T
TOUCH SCREEN (Optional)			
Touch Screen Technology	5- Wire Analog Resistive		
Interface	USB 1.1 and Serial RS-232		
Resolution	4096 x 4096		
Positional Accuracy (Maximum Error)	0.18" (4.6 mm)		0.19" (4.8 mm)
Positional Accuracy (Standard Deviation of Error)	<0.08" (<2.0 mm)		
Screen Finish	Anti-Reflective, Surface Durability - 3H per ASTM D3363		
Chemical Resistance	Acetone, Methylene Chloride, MEK, Isopropyl Alcohol, Hexane, Turpentine, Mineral Spirits, Unleaded gasoline, Diesel fuel, Motor oil, Transmission fluid, Antifreeze, vinegar, ammonia-based glass cleaner.		
Electrostatic Protection	Per EN 61000-4-2, 1995, Withstands 20 discharges up to 15 kV		
Expected Life	>35,000,000 Activations		



Supported PC Video Modes

Video Modes						
Mode	Dot Clock (MHz)	Horizontal Freq (KHz)	Vertical Freq (Hz)	H Sync Polarity	V Sync Polarity	Display Modes for Best Image Quality
640 x 350 @ 70Hz	25.144	31.430	70.000	P	N	
640 x 400 @ 70Hz	28.287	31.430	70.000	N	P	
720 x 400 @ 70Hz	28.287	31.430	70.000	N	P	
640 x 480 @ 60Hz	25.175	31.469	59.940	N	N	
640 x 480 @ 72Hz	31.500	37.861	59.940	N	N	
640 x 480 @ 75Hz	31.500	37.500	75.000	N	N	
800 x 600 @ 56Hz	36.000	35.156	56.250	P	P	
800 x 600 @ 60Hz	40.000	37.879	60.317	P	P	
800 x 600 @ 72Hz	50.000	48.077	72.188	P	P	
800 x 600 @ 75Hz	49.500	46.875	75.000	P	P	
1024 x 768 @ 60Hz	65.000	48.363	60.005	N	N	ATM1500/ATM1500T
1024 x 768 @ 70Hz	75.000	56.476	70.070	N	P	ATM1500/ATM1500T
1024 x 768 @ 75Hz	78.750	60.023	75.030	P	P	ATM1500/ATM1500T
1280 x 1024 @ 60Hz	108.000	63.981	60.020	P	P	ATM1700/ATM1700T & ATM1900/ATM1900T
1280 x 1024 @ 75Hz	135.000	79.976	75.035	P	P	ATM1700/ATM1700T & ATM1900/ATM1900T



Atlas™ Industrial Grade LCD Monitors

These heavy duty PC monitors offer superb quality at a competitive price. Their compact size and very thin panel mounted depth (less than 2.75") allows them to be used in size restricted projects. And the hazardous locations listing makes them ideal for installation in harsh environments found in many factory automation applications. All sizes are available in non-touch or with a 5-wire analog resistive touchscreens. There are currently three sizes, 15", 17", and 19", in this series.

The ATLAS series includes 15" XGA, 17" SXGA, and 19" SXGA LCD monitors. All models come standard with 100-240 VAC input power supplies and have NEMA 4/4X/12 panel-mountable front bezels. All units provide Analog Video (VGA) and Digital Video Input (DVI) connections and 5-wire analog resistive touchscreen "T" models supply connection via either USB or RS-232. The entire series is UL/cUL listed, complies with European CE and RoHS requirements, and is UL approved for Class I Division 2, Class II Division 2 and Class III hazardous locations.



UL Approved for Class I Division 2 and Class 3 Hazardous Locations

Integrated Power Supply



Features

- Optional non-touch or 5-wire analog resistive touch screen available
- UL 508 and ANSI/ISA 12.12.01 listed for Hazardous Locations: Class I, Division 2, Groups A, B, C, D; Class II, Division 2, Groups F and G and Class III.
- NEMA 4/4X/12 front bezel
- RoHS compliant
- Integral 100-240 VAC power supply
- RS-232 and USB support for touch screen models
- Simplified installation with no studs
- VESA compliant - all modes up to SXGA, 16 million colors
- 2-year warranty

ATM1500
\$1,030.00

ATM1500T (touch)
\$1,237.00



ATM1500 - 15"

- 15" color TFT LCD display
- XGA, 1024 x 768 native resolution
- 16 million colors
- 40,000 hrs backlight Life
- Integral 100-240 VAC power supply
- Simplified installation with no studs
- Thin design - only 2.4" behind bezel
- (DVI) Digital Video Inputs
- Accepts analog 15-pin video input

ATM1700
\$1,299.00

ATM1700T (touch)
\$1,506.00



ATM1700 - 17"

- 17" color TFT LCD display
- SXGA, 1280 x 1024 native resolution
- 16 million colors
- 50,000 hrs backlight life
- Integral 100-240 VAC power supply
- Simplified installation with no studs
- Thin design - only 2.6" behind bezel
- (DVI) Digital Video Inputs
- Accepts analog 15-pin video input

ATM1900
\$1,610.00

ATM1900T (touch)
\$1,817.00



ATM1900 - 19"

- 19" color TFT LCD display
- SXGA, 1280 x 1024 native resolution
- 16 million colors
- 40,000 hrs backlight life
- Integral 100-240 VAC power supply
- Simplified installation with no studs
- Thin design - only 2.7" behind bezel
- (DVI) Digital Video Inputs
- Accepts analog 15-pin video input

Quality Industrial Monitors at a Great Price!



15" ATLAS	17" ATLAS	19" ATLAS
\$1,030.00 ATM1500	\$1,299.00 ATM1700	\$1,610.00 ATM1900
\$1,237.00 ATM1500T	\$1,506.00 ATM1700T	\$1,817.00 ATM1900T

"T" models have resistive touchscreens

**UL, cUL, CE approved
NEMA 4/4X/12, IP65
FCC 47 CFR, Part
15, Class A Bezel
Construction**

Bezel Construction:
0.25" Machined Aluminum with a recessed gasket pocket to keep moisture out and powder coated treated with an attractive dark gray textured powder coating

Impact Window:
.125" Lexan (Polycarbonate) with a clear hard coat

FRONT

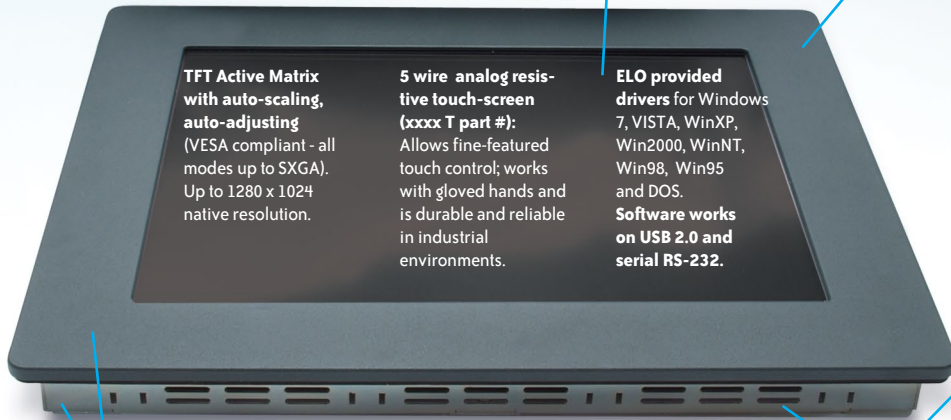

TFT Active Matrix with auto-scaling, auto-adjusting (VESA compliant - all modes up to SXGA). Up to 1280 x 1024 native resolution.

5 wire analog resistive touch-screen (xxxx T part #): Allows fine-featured touch control; works with gloved hands and is durable and reliable in industrial environments.

ELO provided drivers for Windows 7, VISTA, WinXP, Win2000, WinNT, Win98, Win95 and DOS. **Software works on USB 2.0 and serial RS-232.**

Simplified installation with no studs, housed in a heavy duty steel chassis with a powder coated machined aluminum bezel (mounting clips included)

Screen setup via rear keypad prevents tampering

"Auto-adjust" button on back panel keypad for easy display optimization

Ventilation located on all sides to reduce heat build-up 0 to 50 °C (32 to 122 °F)

VESA Ready
VESA arm mount ready (100mm)

The **16-gauge RoHS compliant CRS steel chassis** provides corrosion resistance and extra strength.

USB Cable Bracket keeps the USB cable from loosening (included with monitor)

UL Approved for Class 1 Division 2 Hazardous Locations

Integrated Power Supply

Built in Power Supply 100-240 VAC, 50/60 Hz simplifies and reduces installation cost.

CONNECTIONS

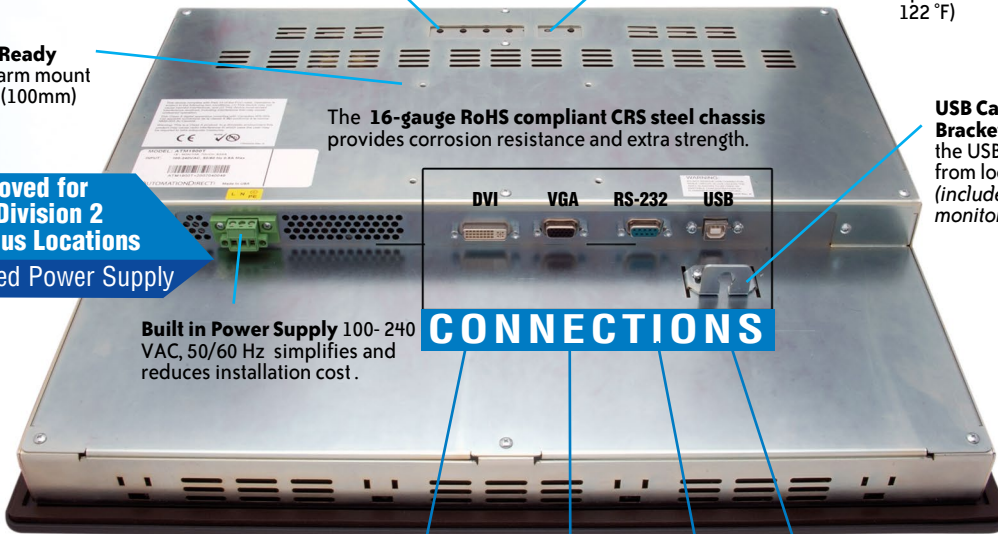

BACK



DVI

VGA

RS-232

USB

Touch models only Touch models only



SIDE

Compact size and very thin panel mount depth of less than 2.75" saves enclosure space

Recessed cable connections conserve panel space

Atlas Industrial Flat Panel PC Monitors

Mounting clip installation

To install the monitor, make a cutout (according to the cutout diagram for the respective monitor) through one of the walls of your NEMA enclosure. Next, hold the monitor in place and install the mounting clips. The monitor uses “U”-shaped clips and a special gasket to achieve a proper seal. Tighten the clips to the point where the back of the monitor’s bezel just begins to contact the front of the NEMA enclosure. The use of an adjustable torque driver is recommended. The screws should be tightened to 8 inch-pounds. Tighten the clips in a cross pattern to develop an even pressure on the sealing gasket. **DO NOT OVERTIGHTEN AS DAMAGE CAN RESULT, CAUSING LOSS OF SEALING INTEGRITY.**

Mounting Clip Diagram

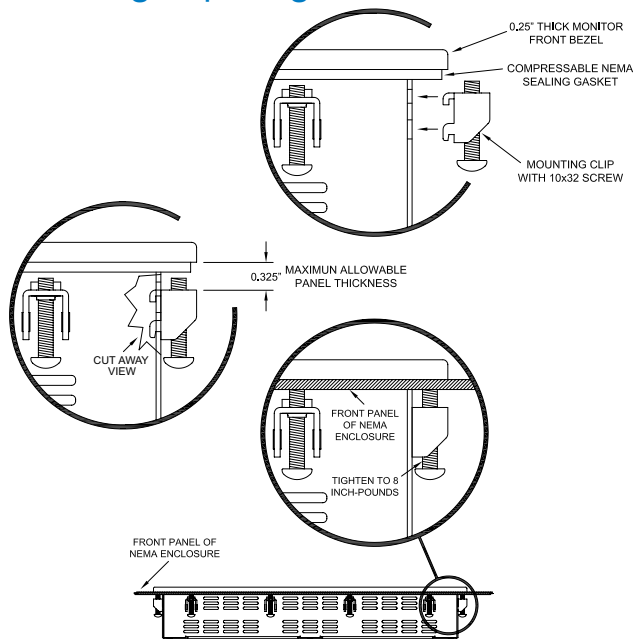

Connecting power

The monitor is powered from 100-240 VAC, 50/60 Hz. Power is connected to the monitor through a removable Phoenix Contact plug (ADC P.N. ATM-AC-CON or Phoenix Contact P.N. 1777992) that allows for screw termination of field wiring. The use of 18 AWG or greater (12 AWG maximum wire) is recommended. Connect the field wiring according to the appropriate table below. After the connections are made, make sure the power connection screws (the two screws shown in the “Front View” below) are securely tightened. This will prevent the plug from pulling out.

Power Wiring Diagram

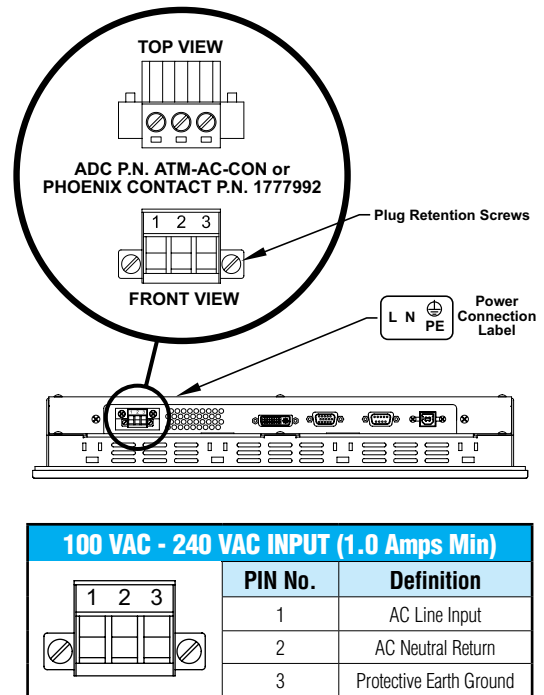

Setting the On-Screen Display (OSD) controls

The On Screen Display (OSD) controls are used for making adjustments to the monitor’s settings and are located on the back of the monitor. They consist of a single LED and five pushbuttons (functions are described in Chapter 3 of the respective monitor’s Hardware User’s Guide) located on the Documentation and Driver CD, or downloadable from the Online Documentation area of the AutomationDirect Web site.

OSD Controls

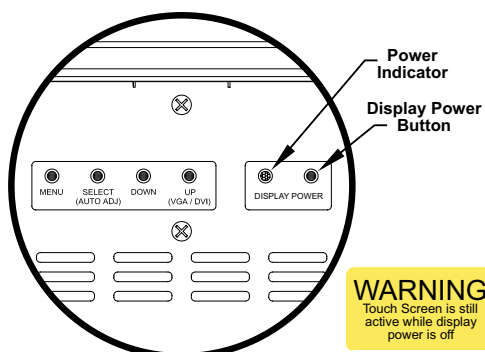

OSD Main Menu Display



Atlas PC Monitor Accessories

Accessories & Replacement Parts

Part Number	Description	Price
ATM-CBL-VGA10	10 ft. 15-pin coaxial VGA cable. Connects any Atlas monitor to a standard VGA card.	\$47.00
ATM-CBL-VGA25	25 ft. 15-pin coaxial VGA cable. Connects any Atlas monitor to a standard VGA card.	\$99.00
ATM-CBL-VGA50	50 ft. 15-pin coaxial VGA cable. Connects any Atlas monitor to a standard VGA card.	\$140.00
ATM-CBL-DV3M	10 ft. (3 meter) DVI (type D) video cable. Connects M1700 and M1900 to a standard DVI-D port. DVI cables provide a higher bandwidth video interface than the VGA cables.	\$73.00
ATM-CBL-10	10 ft. serial communication cable. Connects Atlas monitor to std. 9-pin RS-232 port.	\$26.00
ATM-CBL-25	25 ft. serial communication cable. Connects Atlas monitor to std. 9-pin RS-232 port.	\$47.00
ATM-CBL-50	50 ft. serial communication cable. Connects Atlas monitor to std. 9-pin RS-232 port.	\$69.00
USB-CBL-AB3	3-ft (0.9 meter) Standard USB 2.0 cable with Standard-A plug to Standard-B plug. Suitable for all USB devices.	\$7.75
USB-CBL-AB6	6-ft (1.8 meter) Standard USB 2.0 cable with Standard-A plug to Standard-B plug. Suitable for all USB devices.	\$9.75
USB-CBL-AB10	10-ft (3 meter) Standard USB 2.0 cable with Standard-A plug to Standard-B plug. Suitable for all USB devices.	\$18.50
USB-CBL-AB15	15-ft (4.6 meter) Standard USB 2.0 cable with Standard-A plug to Standard-B plug. Suitable for all USB devices.	\$23.00
ATM-AC-CON	Replacement Power Wiring Connector for AC Powered Units.	\$15.50
ATM-CLIP	Replacement flat panel mounting clip kit. Package of 16 clips and screws.	\$37.00

USB-CBL-AB3



USB-CBL-AB6



USB-CBL-AB10



USB-CBL-AB15



ATM-CBL-VGA10



ATM-CBL-10



ATM-CBL-VGA25



ATM-CBL-25



ATM-AC-CON



ATM-CBL-VGA50



ATM-CBL-50



ATM-CLIP



ATM-CBL-DV3M

