



7P.01/03/05/07 SPD Class I



Utility Model - IB7P01VXX - 07/19
Finder S.p.A. con unico socio
10040 ALMESE (TO) - ITALY

Type	I _{PE} (μA)	U _c V AC (L-N)	U ₀ V AC	Number of port	Dimensions L x W x H (mm)	Approvals	TOV L-N		TOV L-PE	TOV N-PE	System
							5s	120 min	200 ms	200 ms	
7P.01.8.260.1025	< 4	260	230/400 ± 10%	One Port SPD	94 x 36 x 66	VDE, EZU	335 V	440 V	-	-	-
7P.03.8.260.1025	< 4	260			94 x 108 x 66	VDE, EZU	335 V	440 V	-	-	TN-C
7P.05.8.260.1025	< 4	260			94 x 144 x 66	VDE, EZU	335 V	440 V	-	-	TN-S
7P.07.8.260.1025	< 4	260			94 x 72 x 66	VDE, EZU	335 V	440 V	-	-	TN-S

Minimum distance from earthed conductive surface: d = 0

I _{imp} (10/350)	25 kA
I _n (8/20)	30 kA
I _{max} (8/20)	60 kA
I _{SCCR}	50 kA _{rms}
I _L V-connection	max 125 A
V-connection	max 125 A gL/gG
	max 250 A gL/gG
%	5%...95%
°C	-40...+80°C

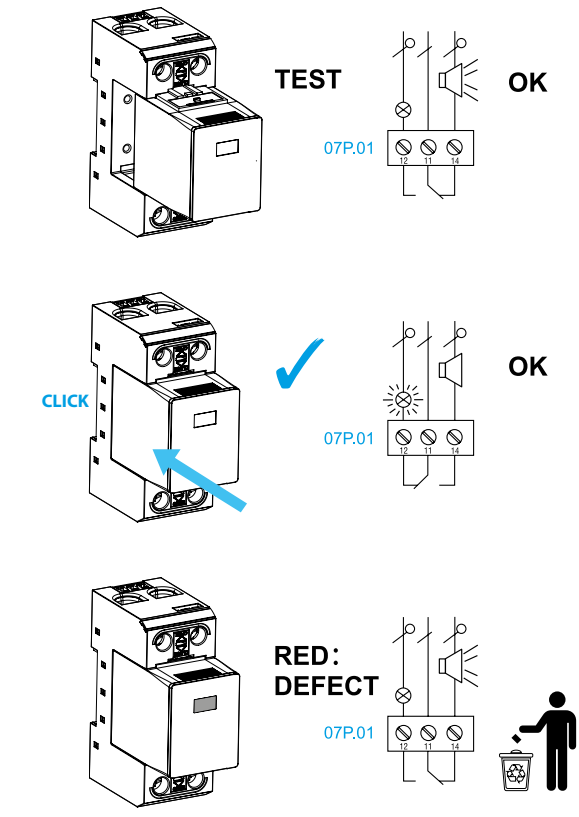
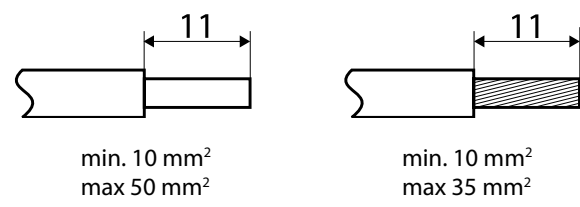
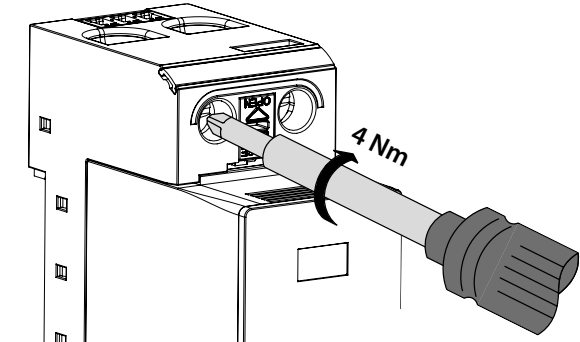
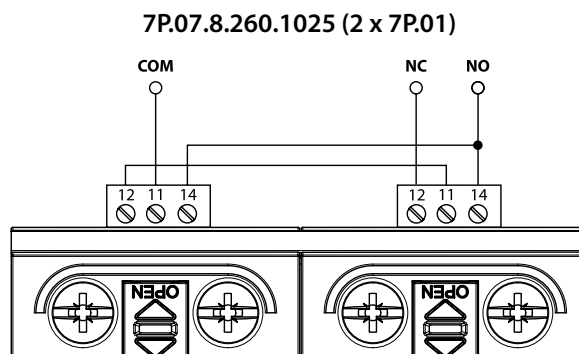

07P.01	1CO (SPDT)
	0.5 A (AC) 250 V AC
	0.1 A (DC) 250 V DC
Max	1.5 mm ² / 30 AWG

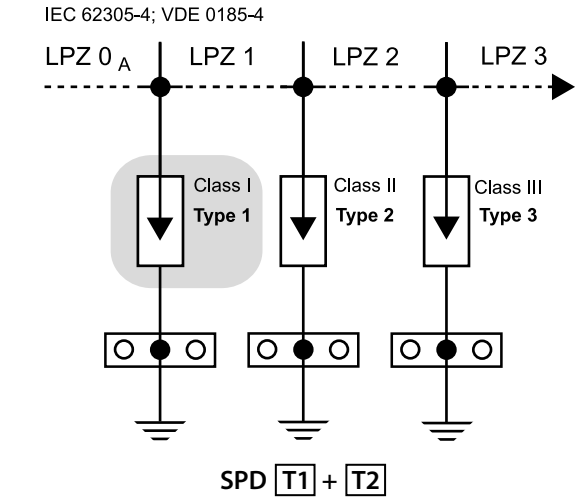
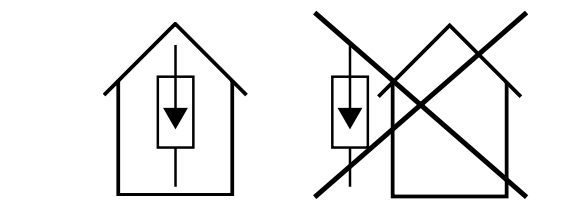
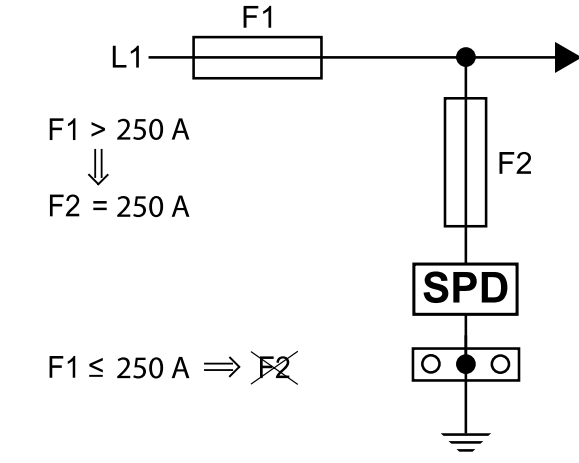
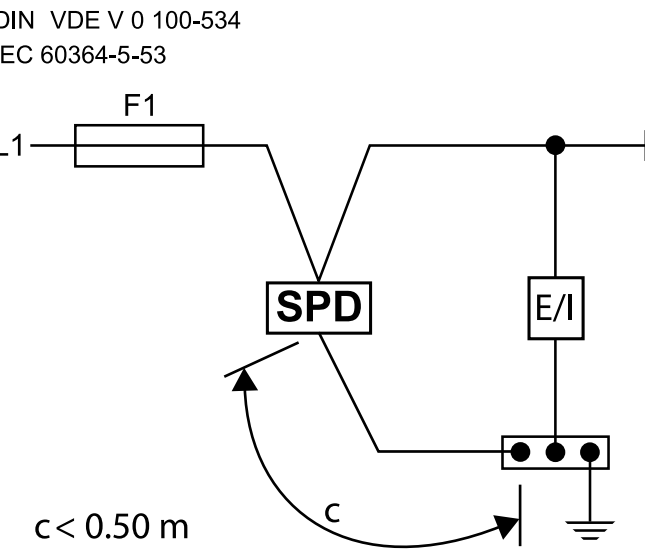
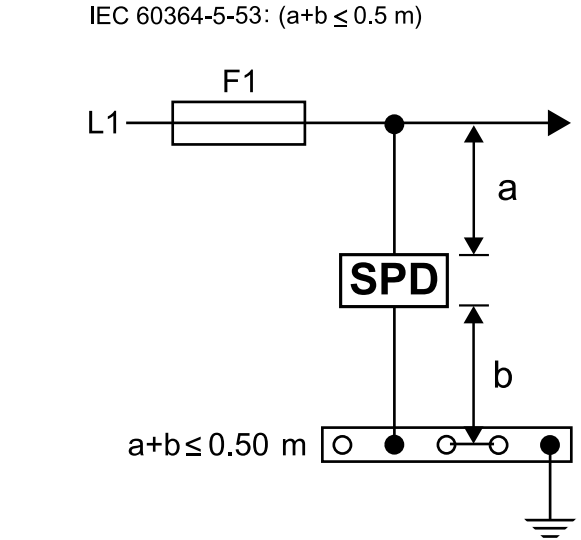

ENGLISH

Finder SPD 7P Series units must be installed only by qualified personnel in accordance with the National standards and the safety regulations (IEC 60364-5-53, VDE 0100-534).

Before installing the unit, verify that it is not damaged and, to avoid the risk of internal condensation, ensure that it has not been stored at low temperature. Opening or modifying the device will void the warranty.

It is important to respect the recommended size of the backup fuse and ensure that the system rated voltage is less than U_c.

Before starting any insulation measurement of the electrical system, it is necessary to extract every replaceable modules out of the base - in order to perform a correct measurement. After measurement, reinsert all the modules into their bases.

