

Your Global Automation Partner

TURCK

电感式传感器



28 subsidiaries and over
60 representations worldwide!

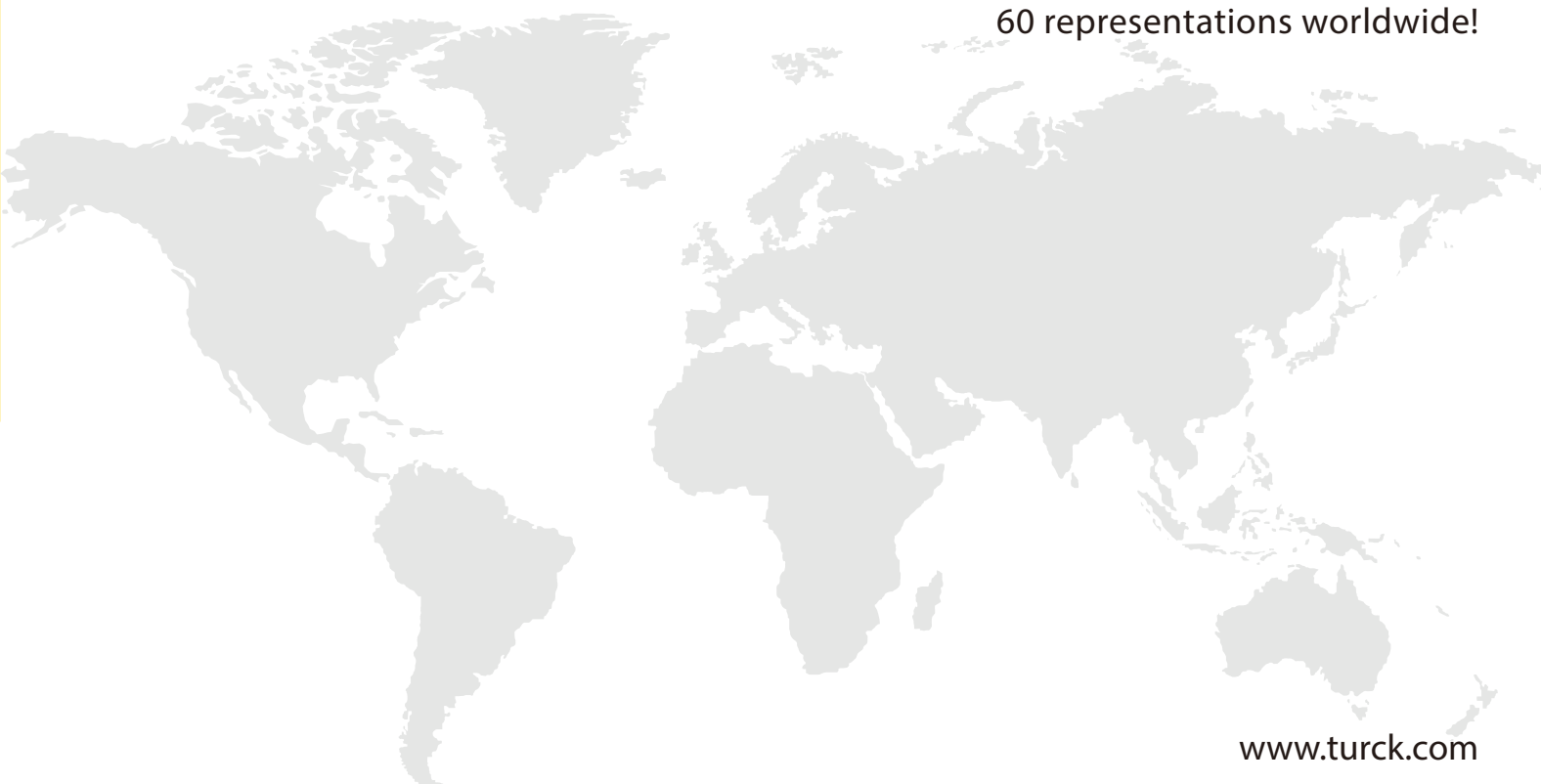

www.turck.com

公司简介

TURCK · 图尔克

TURCK（图尔克）是全球著名的自动化品牌，旗下囊括近15000种丰富多样的传感器产品、工业现场总线产品、过程自动化产品和各类接口及接插件产品，为工厂自动化及过程自动化提供了高效率 and 系统化的全方位解决方案。目前，总部位于德国的图尔克集团已在世界27个国家建立分公司、拥有超过3000名雇员，并通过代理与另外60个国家建立商业往来，年营业额超过4亿欧元。

TURCK（图尔克）作为工业自动化领军企业已有50余年的历史。凭借世界一流的设计、生产技术、全系列的产品线、优异的质量和遍布全球的销售服务网络，TURCK不仅能为用户提供及时专业的技术支持与定制产品，还能确保直接在现场为世界各地的客户提供优质的系统化解决方案。



图尔克·中国

1994年图尔克集团正式在中国投资设立分公司，以便最大化地满足中国市场的需求，并为本地客户提供零距离的定制化服务。同年9月8日，图尔克（天津）传感器有限公司作为德国图尔克集团的全资子公司，在天津经济技术开发区注册成立。

历经20余年的稳健发展，集生产、销售、系统集成、工程服务为一体的图尔克中国公司，已逐步发展成为图尔克集团在亚太地区的生产及销售中心。

目前，图尔克中国公司年销售额逾4.6亿人民币、员工500余人，并分别在北京、上海、广州、武汉、沈阳、无锡、成都、西安等23个城市设立办事处，已成功为10000多家中国客户提供专业的产品和服务，客户遍布全国各行业。

图尔克是值得您信赖的“自动化元器件全系列供应商”和“全方位解决方案提供商”！

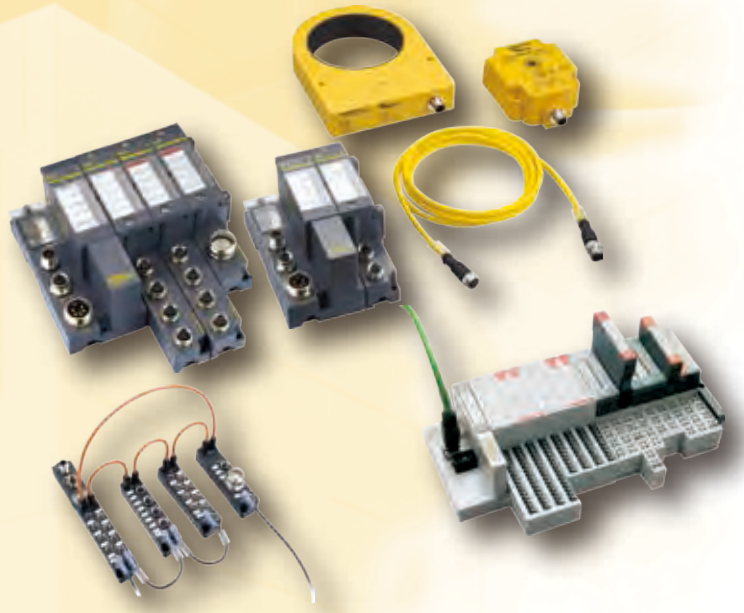
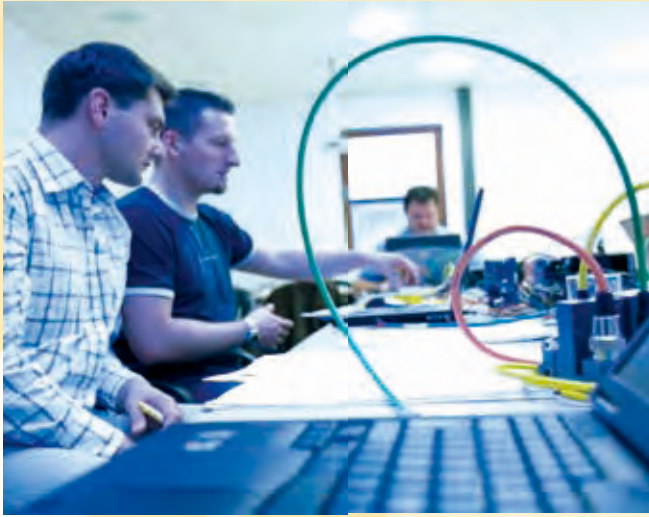

产品范围

TURCK—工业控制领域的首选

四十多年以来 TURCK 为了满足现代工业控制领域的多种需要，已经提供了丰富的解决方案。作为传感器技术的先驱和领导者我们一直关注于电子器件的开发，从而满足制造过程中对自动控制的新挑战。

我们所做的一切均基于一个简单的原因基于 TURCK 在工业自动控制领域丰富的经验，今天我们不但能够提供产品，而且能够提供完善的解决方案用于各类自动控制任务：可提供超过13000种传感器，接口和现场总线技术产品。TURCK 能够给予各种可能的应用以及最高效的产品。这些产品给予我们客户更高的竞争力；最大程度地缩短了失效和停机的时间；实现对生产过程的高效计划和实施。

您理想的合作伙伴

我们的策略明确且极具挑战性：我们要给客户最好、最快捷、最灵活、最可靠的产品。遵循这一宗旨，我们的产品在全世界确保了工业设备高效、高质量和安全的运行。我们坚信只有对新产品和解决方案的不断革新，才能够保障客户和合作伙伴的未来利益。



电感式传感器

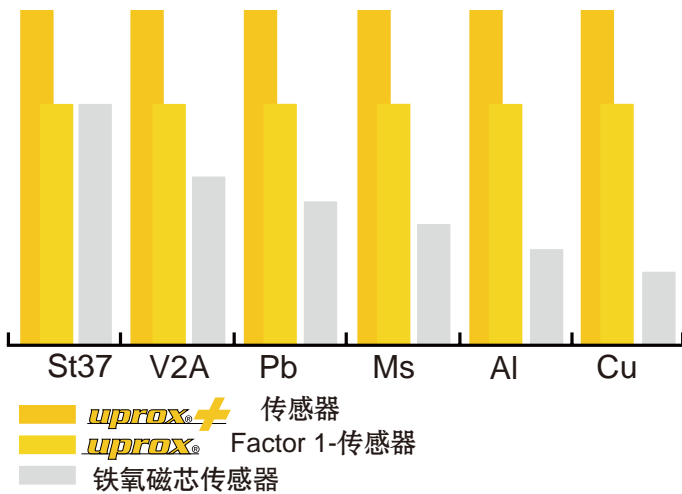

电感式传感器

电感式传感器通过高频交流电磁场以无磨损和非接触的方式检测金属物体。对普通传感器而言，磁场由绕在铁氧体芯线圈上的LC振荡电路产生。通过在金属物体内部产生涡流效应，从而导致LC振荡电路减弱。这一变化能被传感器的防大电路感知。关于电感式传感器的详细资料参看 P312页或P162页。

uprox+ 传感器 (factor 1)

图尔克开发的uprox®传感器以及更进一步的uprox®+传感器，印证了图尔克公司的创新水平及制造技术。基于全新的线圈理念，全新的电感式传感器可以实现真正意义上的全金属检测，而且能有效的防止强磁场的干扰，如焊接环境中或者靠近升降梯或电磁炉的位置，宽温度范围，高等级的EMC特性和更广泛的安装环境等也是它所具备的特性。

外壳材料

除了标准的铜镀铬圆柱形壳体外，还提供以下种类的壳体：抗化学腐蚀和温度突变型（例如应用于食品和饮料行业的冲洗过程时，不锈钢或塑料外壳的圆柱 uprox+传感器是理想的选择）；铜镀特氟龙外壳可提供特殊防护以抗火花和焊接熔渣（例如自动化工业的车体焊接）的飞溅；带Duroplast塑料感应面或带PVDF塑料感应面和Viton“O”型密封圈的特殊密封形式的uprox+传感器可提供最高防护级别的抗化学腐蚀和耐机械压力冲击性能（例如在机加工工业中会频繁使用）。详见P8页的产品概览。

方形传感器多为金属（压铸锌或压铸铝）和塑料外壳。这些材料也可用来制作感应面可调的方形产品或紧凑型（小方形）产品。这些产品可以应用在那些安装空间有限而又需要大检测距离的场合。

特殊应用型电感式传感器

特殊的应用需要有特殊的传感器，uprox®+传感器正是从多方面特性满足了这一点：衰减系数恒为1、抗磁场干扰、IP68/IP69K等。为了保证能够最好的适用于各种特殊环境，TURCK提供了丰富类型的特殊应用型传感器以供选择：

- 环形电感式传感器
- 槽型电感式传感器
- 阀位回讯电感式传感器
- 极限环境应用型传感器（IP69K）
- 深水应用型传感器
- 模拟量输出型传感器
- 转速监控型传感器
- 选择型传感器
- 耐高压传感器
- 温度扩展型传感器
- 磁感应传感器
- 夹钳位置控制型电感式传感器
- 抗强磁场干扰型电感式传感器

目录



传感器概述

— 型号说明	6	1
— 选型指南-标准型传感器	8	
— 选型指南-特殊型传感器	10	

全系列传感器

14

2

特殊型传感器

— 环形电感式传感器	130	3
— 槽型电感式传感器	142	
— 夹钳位置控制型电感式传感器	146	
— uprox® / uprox®+	154	
— 模拟量输出型电感式传感器	208	
— 磁感应式传感器	224	
— 温度扩展型电感式传感器	228	
— 极限环境应用型电感式传感器(IP68/IP69K)	252	
— 深水应用型电感式传感器	264	
— 耐高压型电感式传感器	266	
— 选择型电感式传感器	276	
— 转速监控型电感式传感器	280	

安装附件

286

接插件

300

总说明

— 输出方式

304

— 接线图

312

— 安装指南

316

— 材料

324

— 认证信息及符号说明

330

型号索引

332

4

型号说明—电感式传感器

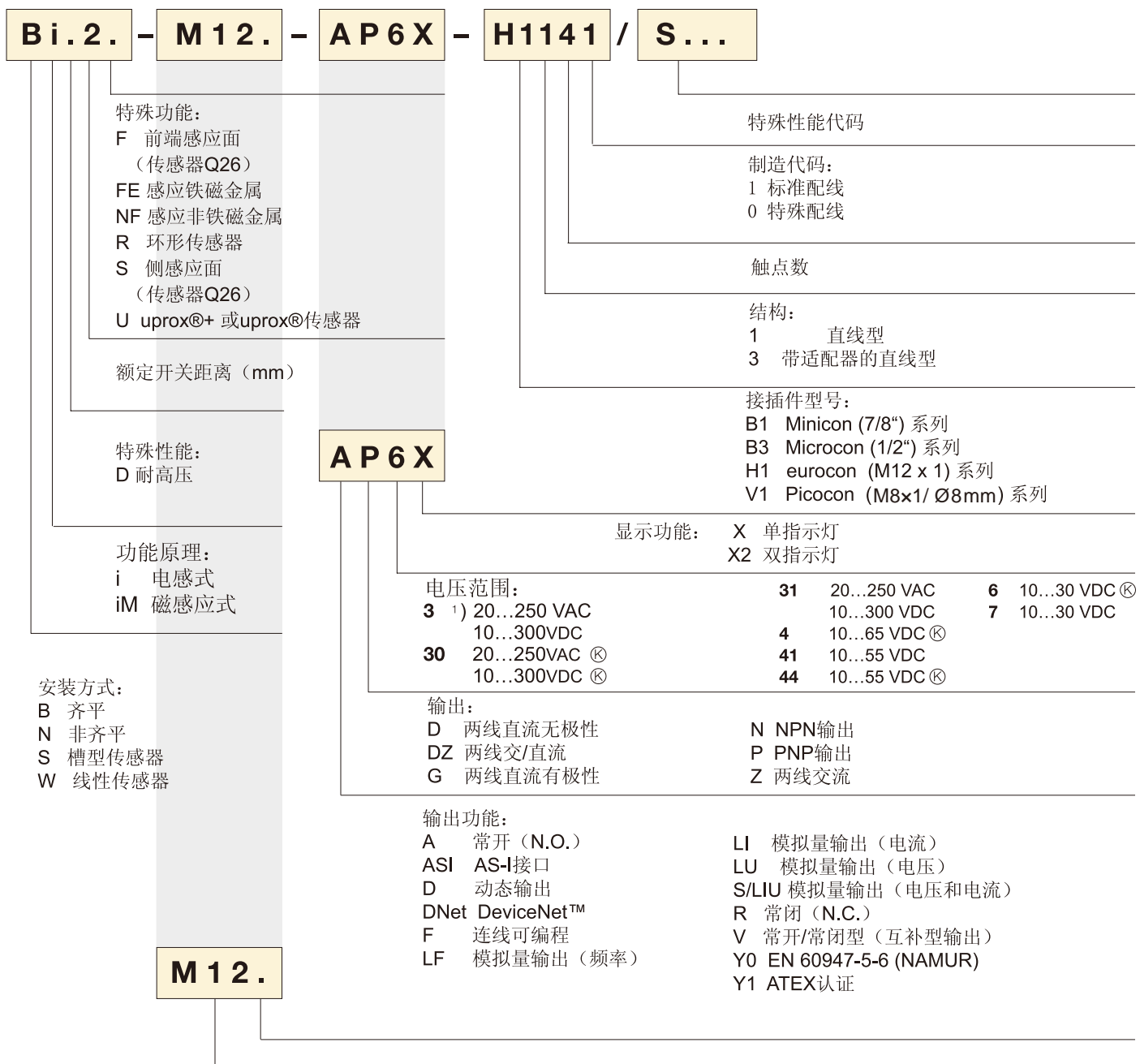

外型描述:

- CA25 stubby®方型 (25 x 25)
- CA40 stubby®方型 (40 x 40)
- CK40 stubby®方型 (40 x 40)
- CP40 combiprox®方型 (40 x 40)
- CP80 CP80方型 (80 x 80)
- DSU 双感应面传感器
- EG 不锈钢圆柱型, 通螺纹
- EH 不锈钢光滑圆柱型
- EM 不锈钢圆柱型, 部分螺纹
- G 铜镀铬圆柱型, 通螺纹
- GS 金属圆柱型, 通螺纹, 侧感应
- H 铜镀铬光滑圆柱型
- HS 金属光滑圆柱型, 侧感应
- K 光滑塑料圆柱型
- M 铜镀铬圆柱型, 部分螺纹

- MT 铜镀特氟龙圆柱型, 部分螺纹
- P 塑料圆柱型, 通螺纹
- Q 方型
- S 塑料圆柱型, 部分螺纹
- TS 塑料扁方型
- W 环形传感器, 塑料外壳

附加外形描述:

- D 耐恶劣气候型
- E 加长型
- M 中等长度
- K 短型
- SR 直或弯角接线端子
- SK 弯角接线端子
- WD 恶劣环境应用型, 抗冲洗

)... AZ3... S120和... NF... AZ3
 只适用于20... 250VAC

选型目录—标准型电感式传感器



型号	高度 [mm]	感应面位置	S _n max [mm]	
				
Q5SE	5	顶部	0.8	-
Q5,5	5.5	顶部	2	3.5
Q06	6	顶部	3	-
Q6,5	6.5	侧面	1	2
Q08	8	顶部	7	-
Q8SE	8	侧面	2 *	4
Q9,5	9.5	侧面	-	2
Q10	10	顶部	8	-
Q10S	10	侧面	2	-
Q12	12	侧面	5	4
TS12	12	下部	-	20
Q14	14	顶部	10	20
Q18	18	侧面	-	5
Q20	20	顶部	15	25
Q25	25	前面	-	10
Q26	26	前面	10	
Q30	30	前面	-	15
Q40	40	前面	-	22
QF15	15	前面	15	22
Q80/ CP80	40	顶部	50	75
Q130	48	侧面	-	30
K90SR	60	顶部	-	100

方型—紧凑、扁平型

金属外壳

接插件 导线 接线端子

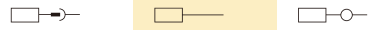

页码

16

18 20

塑料外壳

接插件 导线 接线端子

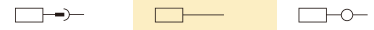

页码

16

16

16

18

18

20

20

22

22

24

24

24

26

26

26

30

26

28

28

36

36

42

42

40

38

38

40

38

32

非齐平传感器齐平安装时的开关距离



型号	感应面 [mm]	S _n max [mm]	
			
CA25	25 x 25	10	15
CA40/CK40 CP40	40 x 40	30	50

方型—可变方向感应面

金属外壳

接插件 导线 接线端子

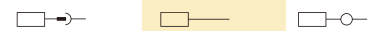

页码

26

塑料外壳

接插件 导线 接线端子

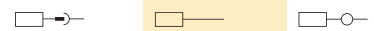

页码

28

32



圆柱螺纹型

型号	S _n max [mm]		
M5 x 0.5	1	-	
M8 x 1	2	6	78
M12 x 1	4	10	90
M18 x 1	8	15	
M30 x 1.5	15	30	
PG36 (G47)	25	40	

金属外壳			塑料外壳		
接插件	导线	接线端子	接插件	导线	接线端子
页码					
42	42				
42	46				
50	60	68	56	62	68
70	84	94	72	82	96
96	106	114	100	104	114
118	116				



光滑圆柱形

型号	S _n max [mm]	
3 mm	1	-
4 mm	1	-
6.5 mm	2	6
11 mm	2	5
20 mm	5	12
34 mm	-	20
40 mm	15	30

金属外壳			塑料外壳		
接插件	导线	接线端子	接插件	导线	接线端子
页码					
	118				
118	118				
120	122				
				124	124
			124	126	126
				126	126
					126

选型指南—特殊应用型电感式传感器



环形电感式传感器

具有集成电路的紧凑且通用的安装外形势图尔克环型传感器的典型特点。它们在自动装配和部分进给系统上有着广泛的应用。例如：在部件输送管路中，小金属部件的检测。环型传感器有静态和动态两种，静态用于断线检测和部件阻塞检测，动态适用于小部件的检测。

P130



槽型电感式传感器

槽型电感式传感器呈“U”型，检测面在两臂间，其适于当物体从侧面接近时检测距离不能准确标定的场合，实现可靠检测。

P142

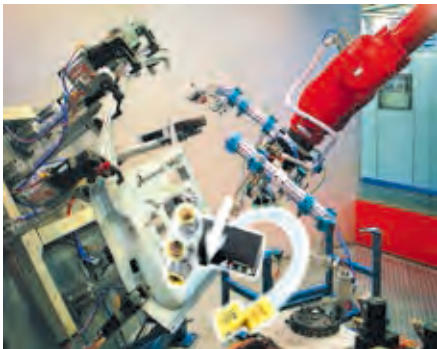

夹钳位置控制型电感式传感器

夹钳位置控制型电感式传感器具有非常大的组合能力，含有40种不同的标准组件和5种不同的电源模块。其典型的检测组件，包括2个微小接近开关构成，实现“开/关”位置检测。

P146



uprox[®]+ factor 1 传感器

基于创新的线圈设计，uprox⁺传感器具有无与伦比的性能特性。其核心技术是采用了具有专利技术的柔性多线圈系统代替了传统的空气芯线圈。极大的开关距离和独特的技术使它成为迄今为止最好的全金属检测FACTOR=1的传感器。

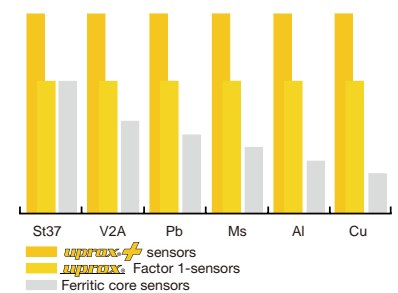

P154



模拟量输出型电感式传感器

图尔克模拟量输出型电感式传感器能提供一个与物体位移成比例的电流、电压或频率信号。适用于简单的监控和控制，并在整个监测范围内信号呈线性。

P208

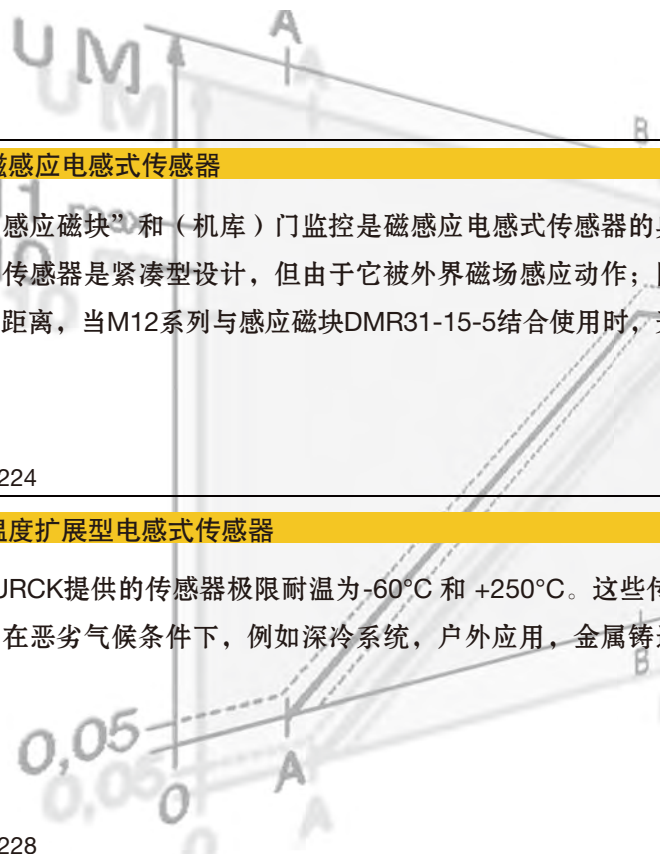

磁感应电感式传感器

“感应磁块”和（机库）门监控是磁感应电感式传感器的典型应用。虽然这种传感器是紧凑型设计，但由于它被外界磁场感动作；因而能产生大的开关距离，当M12系列与感应磁块DMR31-15-5结合使用时，开关距离可达90mm。

P224



温度扩展型电感式传感器

TURCK提供的传感器极限耐温为-60°C 和 +250°C。这些传感器被典型地应用在恶劣气候条件下，例如深冷系统，户外应用，金属铸造或玻璃行业中。

P228



极限环境应用型电感式传感器 (IP69K)

不论应用在食品行业还是应用在机械行业，TURCK的uprox®+耐冲洗传感器能满足所有解决方案的需要，并通过了Henkel-Ecolab测试方法R&D-P3-E No. 37 冲洗和浸泡测试。TURCK能提供耐清洗剂，耐润滑剂和耐润滑油的传感器。TURCK的极限环境应用型电感式传感器不仅达到甚至是超过了IP68+IP69K的防护级别。它们体现了坚固的设计，通过PVDF感应面，特殊的氧化密封圈和不锈钢外壳达到安全防护。

P252



深水应用型电感式传感器

TURCK的深水应用型电感式传感器的外壳可以耐海底特殊压力和海水防护，这些传感器能长时间的应用在深水里正常工作。M18圆柱螺纹型的深水应用型传感器能应用在水下500m深处，安装在防护外壳内的CP40型传感器也能在水下5米处保证IP68防护等级和较大的开关距离。因而它们能用于水闸、水坝和海岸区域。

P264



耐高压电感式传感器

耐高压电感式传感器的问世使应用在高压力环境下成为了可能。耐高压型 uprox®+ 传感器能应用在 20bar 的环境下，并能兼备极大开关距离、衰减系数为1和IP68/IP69K等性能。耐高压电感式传感器表面为不锈钢外壳，非常适用于液压系统，传感器前端具有特殊的密封圈和一个附加的外部“O”型密封圈，保证其能应用于高雅环境，其最高可安装在压力为500bar的环境内。

P266

选型指南—特殊应用型电感式传感器



选择型电感式传感器

TURCK选择型电感式传感器“NF”“FE”和“NF/FE”系列用于区分铁磁金属和非铁磁金属。例如工具和工件的区分，不同材质构成的工件的区分，简单的译码工作。

P276



转速监控型电感式传感器

转速监控型电感式传感器将检测和过程电子装置合并在一个紧凑的外壳中。在转速0—3000u/min的范围内，通过对轴上金属物体或直接对齿轮的检测（用传感器内可调节的过程电子装置的周期性阻尼）来监控过低速或超高速状态。

P280

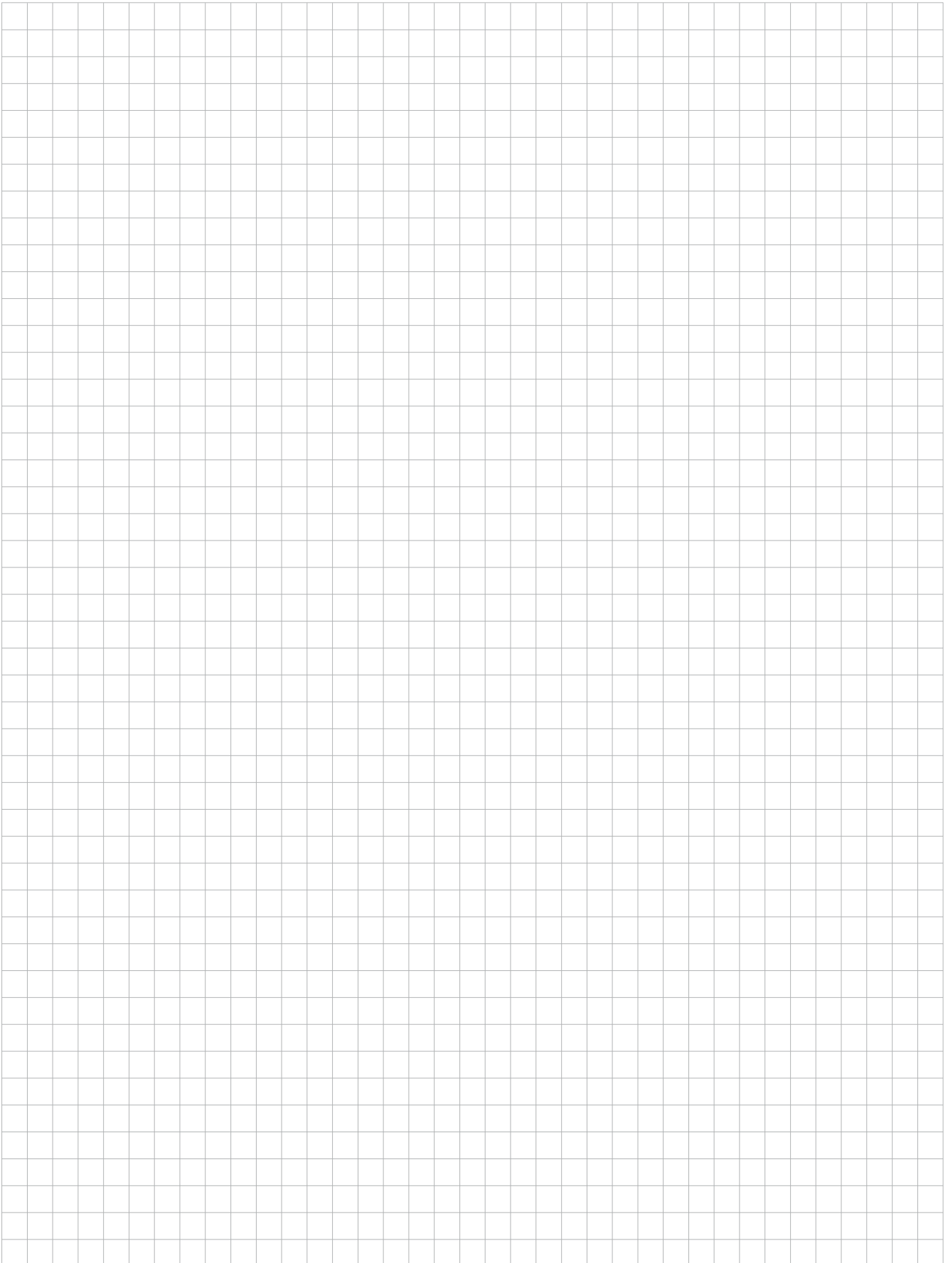

标准型传感器



标准型电感式传感器包括了衰减系数恒为1的uprox 和uprox +传感器, 也同样包括了含有铁氧磁芯的传统型电感式传感器。包含了不同的外型:

- 从5 x 5 x 25 mm到90 x 130 x 60 mm外型的方形传感器, 有较大的开关距离
- 圆柱螺纹型 (M4—PG36)
- 光滑圆柱形 (Ø3mm—Ø40mm)

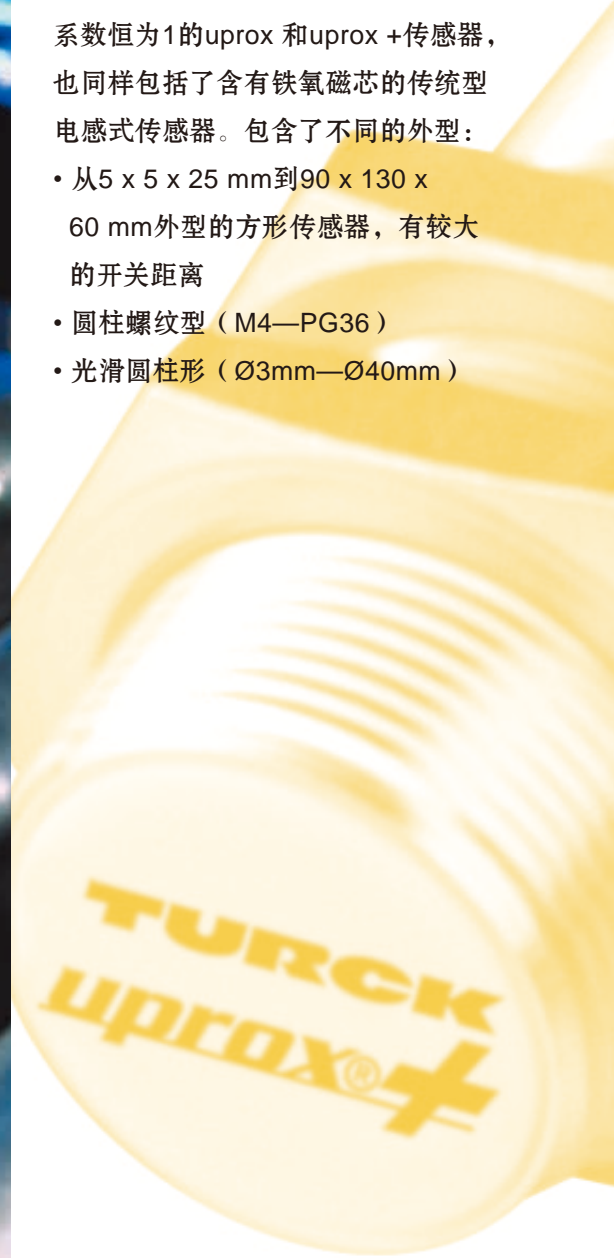

针对传感器的不同应用领域，设计和使用了大量不同的外壳材料，使其能更好的应用在特殊领域。

- 塑料材质 例如：PA、PP、PBT、ABS
- 黄铜材质（圆柱螺纹型），镀铬或特氟龙
- 不锈钢材质

针对不同的需要，有多种规格插接件可供选择：

- 插接件 \varnothing 8 mm、M8、M12、1/2、“7/8”
- 导线长度可选（标准长度为2m）
- M8或M12插接件的专用短线
- 接线端子

标准电感式传感器符合全球电子领域的标准要求：

- NAMUR（本安型）
- 2、3、4线直流
- PNP/NPN输出
- 2线交流/直流
- 连接传感器的总线模块：

DeviceNet™ 或 AS-Interface











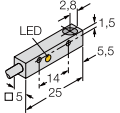



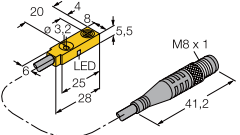



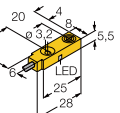











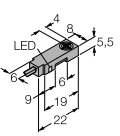



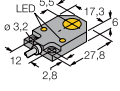

此外，TURCK传感器还取得了多项国际权威认证，保证TURCK传感器能在全世界范围内应用：

- ATEX: 传感器输出检测认证“Y1”（产品代码). 印有这种代码的产品能使用在安全领域。
- SIL 2 /IEC 61508
- ATEX, zone 2或zone 22: 传感器均标记“3D”或“3GD”
- UL: 传感器电压在 30 VDC内
- IEC-Ex: 传感器型标记为“Y1”
- Gost-R

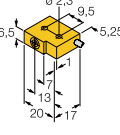
TURCK 为您提供了广泛的产品，能为您复杂多变的应用需求提供近乎完美的解决方案，样本中有些为标准设计，在样本中标准设计的传感器均在双数页中“订货号”一栏中以黄色记号标注。













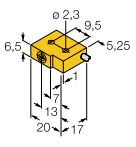

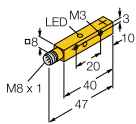



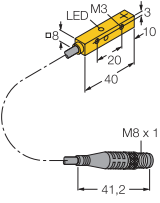

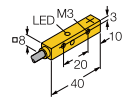

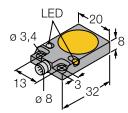

电感式传感器

尺寸/外形	特性	额定工作距离Sn [mm]	输出	工作电压	额定工作电流Ie [mA]	
	Q5SE	-	-	-	-	-
	-	0.8, 	 , PNP	10...30 VDC	100 DC, 	
	Q5,5	-	-	-	-	-
	-	2, 	 , PNP	10...30 VDC	150 DC, 	
	Q5,5	-	-	-	-	-
	抗磁场干扰	2, 	 , PNP	10...30 VDC	150 DC, 	
	-	2, 	 , NPN	10...30 VDC	150 DC, 	
	-	3.5, 	 , PNP	10...30 VDC	150 DC, 	
	-	3.5, 	 , NPN	10...30 VDC	150 DC, 	
	Q5,5K	-	-	-	-	-
		2, 	NAMUR	nom. 8.2 VDC	-	
	-	2, 	 , PNP	10...30 VDC	150 DC, 	
	Q06	-	-	-	-	-
	-	3, 	 , PNP	10...30 VDC	200 DC, 	
	Q6,5	-	-	-	-	-
	抗磁场干扰	1, 	 , PNP	10...30 VDC	150 DC, 	
	-	1, 	 , NPN	10...30 VDC	150 DC, 	

型号	订货号	连接方式 (☞ 322)	开关频率 [kHz]	温度范围 [°C]	防护等级	外壳 (☞ 334)	感应面 (☞ 334)	导线 (☞ 334)	LED U _B	LED └
BI0,8-Q5SE-AP6X	1619341 ✕	S001	3	-25...+70	IP67	AL	POM	PUR 2 m	-	•
BI0,8-Q5SE-AN6X	1619342 ✕	S004	3	-25...+70	IP67	AL	POM	PUR 2 m	-	•
BI2-Q5,5-AP6X-0,3-PSG3M	1613007 ✕	S002	2	-25...+85	IP67	PP	PP	PUR 0.3 m	-	•
BI2-Q5,5-AP6X	1613000 ✕	S001	2	-25...+85	IP67	PP	PP	PUR 2 m	-	•
BI2-Q5,5-AP6X/S34	1613001 ✕	S001	2	-25...+70	IP67	PP	PP	PUR 2 m	-	•
BI2-Q5,5-AN6X	1613100	S004	2	-25...+85	IP67	PP	PP	PUR 2 m	-	•
NI3,5-Q5,5-AP6X	4613601 ✕	S001	2	-25...+70	IP67	PP	PP	PUR 2 m	-	•
NI3,5-Q5,5-AN6X	4613610	S004	2	-25...+70	IP67	PP	PP	PUR 2 m	-	•
BI2-Q5,5K-Y1X	4055300	S025	2	-25...+70	IP67	PA	PA	PUR 2 m	-	•
BI2-Q5,5K-AP6X	1613015	S001	2	-25...+70	IP67	PA	PA	PUR 2 m	-	•
BI2-Q5,5K-AN6X	1613016	S004	2	-25...+70	IP67	PA	PA	PUR 2 m	-	•
BI3-Q06-AP6X2	1620100 ✕	S001	1	-25...+70	IP67	PBT	PA	PUR 2 m	•	•
BI3-Q06-AN6X2	1620150	S004	1	-25...+70	IP67	PBT	PA	PUR 2 m	•	•
BI1-Q6,5-AP6	4613400 ✕	S001	2	-25...+70	IP67	PA12	PA	PUR 2 m	-	-
BI1-Q6,5-AP6/S34	4613401 ✕	S001	0.03	-25...+70	IP67	PA12	PA	PUR 2 m	-	-
BI1-Q6,5-AN6	4613420	S004	2	-25...+70	IP67	PA12	PA	PUR 2 m	-	-

✕ = 优选型号

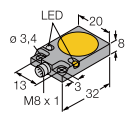









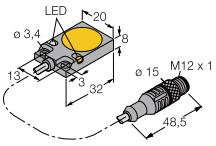



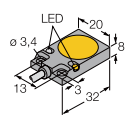







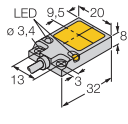

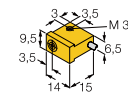

电感式传感器

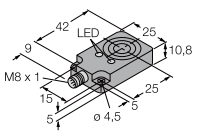
尺寸/外形	特性	额定工作距离Sn [mm]	输出	工作电压	额定工作电流I _e [mA]	
	Q6,5	-	-	10...30 VDC	150 DC, (K)	
	抗磁场干扰	2, 	-, PNP	10...30 VDC	150 DC, (K)	
	-	2, 	-, NPN	10...30 VDC	150 DC, (K)	
	Q8SE	<i>uprox</i> [®] +	4, 	-, PNP	10...30 VDC	150 DC, (K)
		<i>uprox</i> [®] +	4, 	-, PNP	10...30 VDC	150 DC, (K)
		<i>uprox</i> [®] +	4, 	-, NPN	10...30 VDC	150 DC, (K)
		<i>uprox</i> [®] +	4, 	-, NPN	10...30 VDC	150 DC, (K)
		<i>uprox</i> [®] +	4, 	-, PNP	10...30 VDC	150 DC, (K)
	Q8SE	<i>uprox</i> [®] +	4,  / 	-, PNP	10...30 VDC	150 DC, (K)
		<i>uprox</i> [®] +	4,  / 	-, PNP	10...30 VDC	150 DC, (K)
		<i>uprox</i> [®] +	4,  / 	-, NPN	10...30 VDC	150 DC, (K)
	Q08	Sn +	7, 	-, PNP	10...30 VDC	200 DC, (K)
		Sn +	7, 	-, NPN	10...30 VDC	200 DC, (K)
		<i>uprox</i> [®]	5, 	-, PNP	10...30 VDC	200 DC, (K)
		<i>uprox</i> [®]	5, 	-, NPN	10...30 VDC	200 DC, (K)
		-	5, 	-, 2-wire	10...65 VDC	100 DC, (K)
	Q08	<i>uprox</i> [®]	5, 	-, PNP	10...30 VDC	200 DC, (K)

型号	订货号	连接方式 (☞ 322)	开关频率 [kHz]	温度范围 [°C]	防护等级	外壳 (☞ 334)	感应面 (☞ 334)	导线 (☞ 334)	LED U _B	LED ┌
NI2-Q6,5-AP6	4613500 ✕	S001	2	-25...+70	IP67	PA12	PA	PUR 2 m	-	-
NI2-Q6,5-AP6/S34	1650023 ✕	S001	0.03	-25...+70	IP67	PA12	PA	PUR 2 m	-	-
NI2-Q6,5-AN6	4613520	S004	2	-25...+70	IP67	PA12	PA	PUR 2 m	-	-
NI4U-Q8SE-AP6X-V1131	4635808 ✕	S002	1	-30...+85	IP68	PP	PP	-	-	•
NI4U-Q8SE-RP6X-V1131	4635820 ✕	S175	1	-30...+85	IP68	PP	PP	-	-	•
NI4U-Q8SE-AN6X-V1131	4635810	S005	1	-30...+85	IP68	PP	PP	-	-	•
NI4U-Q8SE-AP6X-0.3-PSG3M	4635833	S002	1	-30...+85	IP68	PP	PP	PUR 0.3m with M8x1	-	•
NI4U-Q8SE-RP6X-0.3-PSG3M	4635823	S175	1	-30...+85	IP68	PP	PP	PUR 0.3m with M8x1	-	•
NI4U-Q8SE-AP6X	4635807 ✕	S001	1	-30...+85	IP68	PP	PP	PUR 2 m	-	•
NI4U-Q8SE-RP6X	4635821	S054	1	-30...+85	IP68	PP	PP	PUR 2 m	-	•
NI4U-Q8SE-AN6X	4635809 ✕	S004	1	-30...+85	IP68	PP	PP	PUR 2 m	-	•
BI7-Q08-VP6X2-V1141	1600902	S008	0.5	-25...+70	IP67	GD-Zn	PA	-	•	•
BI7-Q08-VN6X2-V1141	1600922	S011	0.5	-25...+70	IP67	GD-Zn	PA	-	•	•
BI5U-Q08-AP6X2-V1131	1608900 ✕	S002	0.25	-30...+85	IP67	GD-Zn	LCP	-	•	•
BI5U-Q08-AN6X2-V1131	1608910 ✕	S005	0.25	-30...+85	IP67	GD-Zn	LCP	-	•	•
BI5-Q08-AD4X-V1130	4414551	S154	1	-25...+70	IP67	GD-Zn	PA	-	-	•
BI5U-Q08-AP6X2-V2131	1608905 ✕	S002	0.25	-30...+85	IP67	GD-Zn	LCP	-	•	•

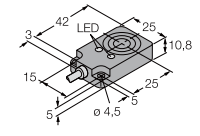
✕ = 优选型号











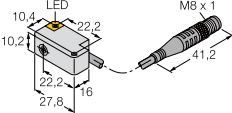



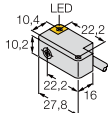











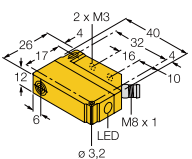

电感式传感器

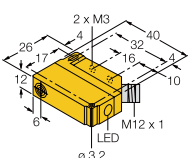
尺寸/外形	特性	额定工作距离Sn [mm]	输出	工作电压	额定工作电流Ie [mA]	
	Q08	<i>uprox</i> [®]	5, 	—, PNP	10...30 VDC	200 DC, (K)
		<i>uprox</i> [®]	5, 	—, PNP	10...30 VDC	200 DC, (K)
	Q08	Sn +	7, 	—, PNP	10...30 VDC	200 DC, (K)
		Sn +	7, 	—, NPN	10...30 VDC	200 DC, (K)
		Ex II 2 G SIL2	5, 	NAMUR	nom. 8.2 VDC	—
		<i>uprox</i> [®]	5, 	—, PNP	10...30 VDC	200 DC, (K)
		—	5, 	—, PNP	10...30 VDC	200 DC, (K)
		<i>uprox</i> [®]	5, 	—, NPN	10...30 VDC	200 DC, (K)
		—	5, 	—, NPN	10...30 VDC	200 DC, (K)
		<i>uprox</i> [®] +	8, 	—, PNP	10...30 VDC	200 DC, (K)
	Q9,5	—	2, 	—, PNP	10...30 VDC	150 DC, (K)
		抗磁场干扰	2, 	—, PNP	10...30 VDC	150 DC, (K)
	Q10	<i>uprox</i> [®]	8, 	—, PNP	10...30 VDC	200 DC, (K)
		<i>uprox</i> [®]	8, 	—, NPN	10...30 VDC	200 DC, (K)
	Q10	<i>uprox</i> [®]	8, 	—, PNP	10...30 VDC	200 DC, (K)
		<i>uprox</i> [®]	8, 	—, NPN	10...30 VDC	200 DC, (K)

型号	订货号	连接方式 (☞ 322)	开关频率 [kHz]	温度范围 [°C]	防护等级	外壳 (☞ 334)	感应面 (☞ 334)	导线 (☞ 334)	LED U _B	LED ┘
BI5U-Q08-AP6X2-0,5X0R-RS4	1608925 ✕	S002	0.25	-30...+85	IP67	GD-Zn	LCP	PVC 0.5 m	•	•
BI5U-Q08-AP6X2-1X0R-RS4	1608921 ✕	S002	0.25	-30...+85	IP67	GD-Zn	LCP	PVC 1 m	•	•
BI7-Q08-VP6X2	1600900 ✕	S007	1	-25...+70	IP67	GD-Zn	PA	PUR 2 m	•	•
BI7-Q08-VN6X2	1600920	S010	0.5	-25...+70	IP67	GD-Zn	PA	PUR 2 m	•	•
BI5-Q08-Y1X	4054000 ✕	S025	1	-25...+70	IP67	GD-Zn	PA	PVC 2 m	-	•
BI5U-Q08-AP6X2	1608901 ✕	S001	0.25	-30...+85	IP67	GD-Zn	LCP	PUR 2 m	•	•
BI5-Q08-VP6X2	16001 ✕	S007	1	-25...+70	IP67	GD-Zn	PA	PUR 2 m	•	•
BI5U-Q08-AN6X2	1608911 ✕	S004	0.25	-30...+85	IP67	GD-Zn	LCP	PUR 2 m	•	•
BI5-Q08-VN6X2	16002 ✕	S010	1	-25...+70	IP67	GD-Zn	PA	PUR 2 m	•	•
BI8U-Q08-RP6X2	1662012 ✕	S054	0.25	-25...+70	IP68	GD-Zn	PP	PUR 2 m	•	•
NI2-Q9,5-AP6	1650080	S001	2	-25...+70	IP67	PA	PA	PUR 2 m	-	-
NI2-Q9,5-AP6/S34	1650077	S001	1	-25...+70	IP67	PP	PA	PUR 2 m	-	-
BI8U-Q10-AP6X2-V1131	1662002 ✕	S002	0.25	-30...+85	IP67	PBT	PBT	-	•	•
BI8U-Q10-AN6X2-V1131	1662004	S005	0.25	-30...+85	IP67	PBT	PBT	-	•	•
BI8U-Q10-AP6X2	1662001 ✕	S001	0.25	-30...+85	IP67	PBT	PBT	PUR 2 m	•	•
BI8U-Q10-AN6X2	1662003	S004	0.25	-30...+85	IP67	PBT	PBT	PUR 2 m	•	•

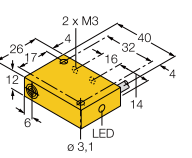
✕ = 优选型号











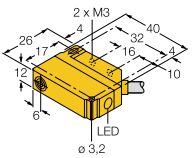







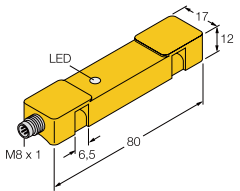
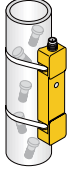



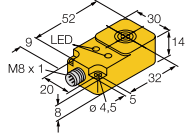





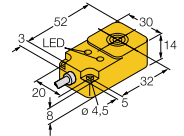

电感式传感器

尺寸/外形	特性	额定工作距离Sn [mm]	输出	工作电压	额定工作电流Ie [mA]	
	Q10S	-	—, PNP	10...30 VDC	150 DC, (K)	
	 uprox®+	5, 	—, NPN	10...30 VDC	150 DC, (K)	
	uprox®+	5, 	—, PNP	10...30 VDC	150 DC, (K)	
	Q10S	 II 1 G  II 1 D SIL2	2, 	NAMUR	nom. 8.2 VDC	-
		-	2, 	—, PNP	10...30 VDC	150 DC, (K)
		-	2, 	—, PNP	10...30 VDC	150 DC, (K)
		-	2, 	—, NPN	10...30 VDC	150 DC, (K)
		-	2, 	—, NPN	10...30 VDC	150 DC, (K)
		-	2, 	—	20...250 VAC 10...300 VDC	100 AC 100 DC
		uprox®+	5, 	—, NPN	10...30 VDC	150 DC, (K)
		uprox®+	5, 	—, PNP	10...30 VDC	150 DC, (K)
	Q12	uprox®+	5, 	—, PNP	10...30 VDC	200 DC, (K)
		uprox®+	5, 	—, PNP	10...30 VDC	200 DC, (K)
		uprox®+	5, 	—, NPN	10...30 VDC	200 DC, (K)
	Q12	uprox®+	5, 	—, PNP	10...30 VDC	200 DC, (K)
		uprox®+	5, 	—, NPN	10...30 VDC	200 DC, (K)
		uprox®+	5, 	—, PNP	10...30 VDC	200 DC, (K)
	Q12	-	2, 	20...250 VAC 10...300 VDC	100 AC 100 DC	
		-	4, 	20...250 VAC 10...300 VDC	100 AC 100 DC	

型号	订货号	连接方式 (☞ 322)	开关频率 [kHz]	温度范围 [°C]	防护等级	外壳 (☞ 334)	感应面 (☞ 334)	导线 (☞ 334)	LED U _B	LED ┌
BI2-Q10S-AP6X-0,2-PSG3M	1609303 ✘	S002	2	-25...+70	IP67	PP	PP	PUR 0.2m with M8x1	-	•
NI5U-Q10S-AN6X-0.3-PSG3M	1609367	S005	1	-30...+85	IP68	PP	PP	PUR 0.3m with M8x1	-	•
NI5U-Q10S-AP6X-0.3-PSG3M	1609366	S002	1	-30...+85	IP68	PP	PP	PUR 0.3m with M8x1	-	•
BI2-Q10S-Y1X	4012130	S025	1	-25...+70	IP67	PP	PP	PVC 2 m	-	•
BI2-Q10S-AP6X	1609360 ✘	S001	2	-25...+70	IP67	PP	PP	PUR 2 m	-	•
BI2-Q10S-VP6X	1609340	S007	2	-25...+70	IP67	PP	PP	PUR 2 m	-	•
BI2-Q10S-AN6X	1619310	S004	2	-25...+70	IP67	PP	PP	PUR 2 m	-	•
BI2-Q10S-VN6X	1609341	S010	2	-25...+70	IP67	PP	PP	PUR 2 m	-	•
BI2-Q10S-AZ31X	1309100 ✘	S092	0.06	-25...+70	IP67	PP	PP	PUR 2 m	-	•
NI5U-Q10S-AN6X	1609365	S004	1	-30...+85	IP68	PP	PP	PUR 2m	-	•
NI5U-Q10S-AP6X	1609364	S001	1	-30...+85	IP68	PP	PP	PUR 2m	-	•
BI5U-Q12-AP6X2-V1131	1635524 ✘	S002	1	-25...+70	IP68	PA	PA	-	•	•
BI5U-Q12-AP6X2-V1131/F2	1635528 ✘	S002	1	-25...+70	IP68	PA	PA	-	•	•
BI5U-Q12-AN6X2-V1131	1635525 ✘	S005	1	-25...+70	IP68	PA	PA	-	•	•
BI5U-Q12-AP6X2-H1141	1635526 ✘	S002	1	-25...+70	IP68	PA	PA	-	•	•
BI5U-Q12-AN6X2-H1141	1635527	S005	1	-25...+70	IP68	PA	PA	-	•	•
BI5U-Q12-VP6X2-H1141	1635534	S008	1	-25...+70	IP68	PA	PA	-	•	•
BI2-Q12-AZ31X	13100 ✘	S092	0.02	-25...+70	IP67	PA	PA	PVC 2 m	-	•
NI4-Q12-AZ31X	13102 ✘	S092	0.02	-25...+70	IP67	PA	PA	PVC 2 m	-	•

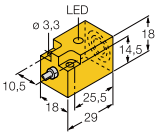
✘ = 优选型号

电感式传感器

尺寸/外形	特性	额定工作距离Sn [mm]	输出	工作电压	额定工作电流Ie [mA]	
	Q12 	<i>uprox</i> [®] +	5, 	—, PNP	10...30 VDC	200 DC, (K)
		<i>uprox</i> [®] +	5, 	—, PNP	10...30 VDC	200 DC, (K)
		<i>uprox</i> [®] +	5, 	—, NPN	10...30 VDC	200 DC, (K)
		<i>uprox</i> [®] +	5, 	—, NPN	10...30 VDC	200 DC, (K)
		<i>uprox</i> [®] +	5, 	—, NPN	10...30 VDC	200 DC, (K)
		<i>uprox</i> [®] +	5, 	—, NPN	10...30 VDC	200 DC, (K)
 	TS12 	<i>uprox</i> [®] +	20, 	—, PNP	10...30 VDC	200 DC, (K)
		<i>uprox</i> [®] +	20, 	—, NPN	10...30 VDC	200 DC, (K)
	Q14 	<i>uprox</i> [®]	10, 	—, PNP	10...30 VDC	200 DC, (K)
		<i>uprox</i> [®]	10, 	—, NPN	10...30 VDC	200 DC, (K)
		—	20, 	—, PNP	10...30 VDC	200 DC, (K)
		—	20, 	—, NPN	10...30 VDC	200 DC, (K)
	Q14 	<i>uprox</i> [®]	10, 	—, PNP	10...30 VDC	200 DC, (K)
		<i>uprox</i> [®]	10, 	—, NPN	10...30 VDC	200 DC, (K)
		Ex II 2 G SIL2 抗磁场干扰	10, 	NAMUR	nom. 8.2 VDC	—
		—	10, 	—	20...250 VAC 10...300 VDC	100 AC 100 DC, (K)
		—	10, 	—	20...250 VAC 10...300 VDC	100 AC 100 DC, (K)
		—	20, 	—, PNP	10...30 VDC	200 DC, (K)
		—	20, 	—, NPN	10...30 VDC	200 DC, (K)
			Q18 	—	5, 	—, PNP
—	5, 			—, NPN	10...30 VDC	200 DC, (K)

型号	订货号	连接方式 (☞ 322)	开关频率 [kHz]	温度范围 [°C]	防护等级	外壳 (☞ 334)	感应面 (☞ 334)	导线 (☞ 334)	LED U _B	LED ┘
BI5U-Q12-AP6X2	1635522 ✕	S001	1	-25...+70	IP68	PA	PA	PUR 2 m	•	•
BI5U-Q12-VP6X2 7M	1635529	S007	1	-25...+70	IP68	PA	PA	PUR 2 m	•	•
BI5U-Q12-AN6X2	1635523	S004	1	-25...+70	IP68	PA	PA	PUR 2 m	•	•
BI5U-Q12-VN6X2 7M	1635531	S010	1	-25...+70	IP68	PA	PA	PUR 2 m	•	•
BI5U-Q12-VP6X2	1635533	S007	1	-25...+70	IP68	PA	PA	PUR 2 m	•	•
BI5U-Q12-VP6X2/F2	1635535	S007	1	-25...+70	IP68	PA	PA	PUR 2 m	•	•
NI20U-TS12-AP6X2-V1131	1646640 ✕	S002	0.008	-25...+70	IP68	PBT	-	-	•	•
NI20U-TS12-AN6X2-V1131	1625822	S005	0.008	-25...+70	IP68	PBT	-	-	•	•
BI10U-Q14-AP6X2-V1131	1608500 ✕	S002	0.25	-30...+85	IP67	PBT	PBT	-	•	•
BI10U-Q14-AN6X2-V1131	1608510 ✕	S005	0.25	-30...+85	IP67	PBT	PBT	-	•	•
NI20-Q14-AP6X2-V1131	4690210 ✕	S002	0.25	-25...+70	IP67	PBT	PBT	-	•	•
NI20-Q14-AN6X2-V1131	4690221	S005	0.25	-25...+70	IP67	PBT	PBT	-	•	•
BI10U-Q14-AP6X2	1608700 ✕	S001	0.25	-30...+85	IP67	PBT	PBT	PUR 2 m	•	•
BI10U-Q14-AN6X2	1608710 ✕	S004	0.25	-30...+85	IP67	PBT	PBT	PUR 2 m	•	•
BI10-Q14-Y1X	1608730	S025	1	-25...+70	IP67	PBT	PBT	PVC 2 m	-	•
BI10-Q14-ADZ32X2/S34	4256225	S092	0.02	-25...+70	IP67	PBT	PBT	PUR 2 m	•	•
BI10-Q14-ADZ32X2	4256220	S092	0.02	-25...+70	IP67	PBT	PBT	PUR 2 m	•	•
NI20-Q14-AP6X2	4690205 ✕	S001	0.25	-25...+70	IP67	PBT	PBT	PUR 2 m	•	•
NI20-Q14-AN6X2	4690220	S004	0.25	-25...+70	IP67	PBT	PBT	PUR 2 m	•	•
NI5-Q18-AP6X	4614606 ✕	S001	0.5	-25...+70	IP67	PBT	PBT	PVC 2 m	-	•
NI5-Q18-AN6X	4614607	S004	0.5	-25...+70	IP67	PBT	PBT	PVC 2 m	-	•

✕ = 优选型号











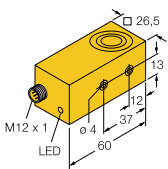



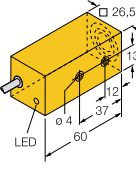

电感式传感器

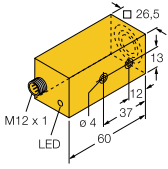
尺寸/外形	特性	额定工作距离Sn	输出	工作电压	额定工作电流Ie	
	(Ex 356)	[mm]			[mA]	
	Q20	<i>uprox</i> [®]	15,	—, PNP	10...30 VDC	200 DC, K
		<i>uprox</i> [®]	15,	—, NPN	10...30 VDC	200 DC, K
		Ex II 2 G SIL2	15,	NAMUR	nom. 8.2 VDC	—
		—	25,	—, PNP	10...30 VDC	200 DC, K
		—	25,	—, NPN	10...30 VDC	200 DC, K
	Q20	<i>uprox</i> [®]	15,	—, PNP	10...30 VDC	200 DC, K
		<i>uprox</i> [®]	15,	—, NPN	10...30 VDC	200 DC, K
		Ex II 2 G SIL2	15,	NAMUR	nom. 8.2 VDC	—
		—	25,	—, PNP	10...30 VDC	200 DC, K
		—	25,	—, NPN	10...30 VDC	200 DC, K
	Q25	—	10,	—, PNP	10...30 VDC	200 DC, K
		—	10,	—, NPN	10...30 VDC	200 DC, K
	CA25	harsh <i>uprox</i> [®]	10,	—, PNP	10...30 VDC	200 DC, K
		harsh <i>uprox</i> [®]	15,	—, PNP	10...30 VDC	200 DC, K
	CA25	harsh <i>uprox</i> [®]	10,	—, PNP	10...30 VDC	200 DC, K
		harsh <i>uprox</i> [®]	15,	—, PNP	10...30 VDC	200 DC, K
	Q26	抗磁场干扰	10,	—, 2-wire	10...65 VDC	100 DC, K

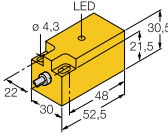
型号	订货号	连接方式 (☞ 322)	开关频率 [kHz]	温度范围 [°C]	防护等级	外壳 (☞ 334)	感应面 (☞ 334)	导线 (☞ 334)	LED U _B	LED ┘
BI15U-Q20-AP6X2-H1141	1608600 ✕	S002	0.25	-30...+85	IP67	PBT	PBT	-	•	•
BI15U-Q20-AN6X2-H1141	1608610	S005	0.25	-30...+85	IP67	PBT	PBT	-	•	•
BI15-Q20-Y1X-H1141	1080025	S026	1	-25...+70	IP67	PBT	PBT	-	-	•
NI25-Q20-AP6X2-H1141	1602702 ✕	S002	0.25	-25...+70	IP67	PBT	PBT	-	•	•
NI25-Q20-AN6X2-H1141	1602802	S005	0.25	-25...+70	IP67	PBT	PBT	-	•	•
BI15U-Q20-AP6X2	1608800 ✕	S001	0.25	-30...+85	IP67	PBT	PBT	PUR 2 m	•	•
BI15U-Q20-AN6X2	1608810 ✕	S004	0.25	-30...+85	IP67	PBT	PBT	PUR 2 m	•	•
BI15-Q20-Y1X	1080020	S025	1	-25...+70	IP67	PBT	PBT	PVC 2 m	-	•
NI25-Q20-AP6X2	1602700 ✕	S001	0.25	-25...+70	IP67	PBT	PBT	PUR 2 m	•	•
NI25-Q20-AN6X2	1602800	S004	0.25	-25...+70	IP67	PBT	PBT	PUR 2 m	•	•
NI10-Q25-AP6X	4652225 ✕	S001	2	-25...+70	IP67	PBT	PBT	PVC 2 m	-	•
NI10-Q25-AN6X	4652330	S004	2	-25...+70	IP67	PBT	PBT	PVC 2 m	-	•
BI10U-CA25-AP6X2-V1131	1625632 ✕	S002	0.25	-30...+85	IP67	GD-CuZn	DURO	-	•	•
NI15U-CA25-AP6X2-V1131	1625642	S002	0.25	-30...+85	IP67	GD-CuZn	DURO	-	•	•
BI10U-CA25-AP6X2-H1141	1625631 ✕	S002	0.25	-30...+85	IP67	GD-CuZn	DURO	-	•	•
NI15U-CA25-AP6X2-H1141	1625641 ✕	S002	0.25	-30...+85	IP67	GD-CuZn	DURO	-	•	•
BI10S-Q26-AD4X/S34	44702 ✕	S013	0.03	-25...+70	IP67	PBT	PBT	PVC 2 m	-	•

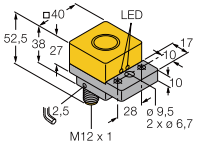
✕ = 优选型号

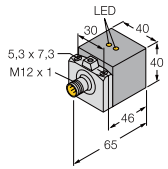









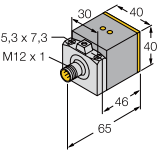





















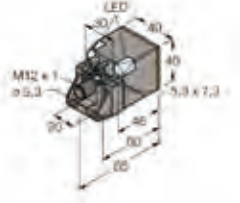



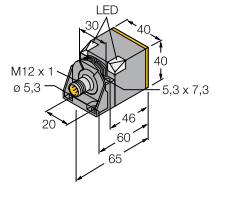



电感式传感器

尺寸/外形	特性	额定工作距离Sn [mm]	输出	工作电压	额定工作电流Ie [mA]	
	Q26	15, 	—, PNP	10...65 VDC	200 DC, 	
	抗磁场干扰 	10, 	—, 2-wire	10...65 VDC	100 DC, 	
	Q26	抗磁场干扰	—, 2-wire	10...65 VDC	100 DC, 	
	Q26	抗磁场干扰	—, 2-wire	10...65 VDC	100 DC, 	
	Q30	—	—, PNP	10...30 VDC	200 DC, 	
		—	—, NPN	10...30 VDC	200 DC, 	
	Q40	<i>uprox</i> [®] +	—, PNP	10...30 VDC	200 DC, 	
	CA40	harsh <i>uprox</i> [®]	—, PNP	10...30 VDC	200 DC, 	
		harsh <i>uprox</i> [®]	—, NPN	10...30 VDC	200 DC, 	

型号	订货号	连接方式 (IEC 322)	开关频率 [kHz]	温度范围 [°C]	防护等级	外壳 (IEC 334)	感应面 (IEC 334)	导线 (IEC 334)	LED U _B	LED ┘
BI10S-Q26-AP4X-H1141/S34	15633 ✕	S002	0.2	-25...+70	IP67	PBT	PBT	-	-	•
BI10S-Q26-AD4X-H1141/S34	44712 ✕	S014	0.03	-25...+70	IP67	PBT	PBT	-	-	•
BI10F-Q26-AD4X/S34	44700 ✕	S013	0.03	-25...+70	IP67	PBT	PBT	PVC 2 m	-	•
BI10F-Q26-AD4X-H1141/S34	44710 ✕	S014	0.03	-25...+70	IP67	PBT	PBT	-	-	•
NI15-Q30-AP6X	4659325 ✕	S001	2	-25...+70	IP67	PBT	PBT	PVC 2 m	-	•
NI15-Q30-AN6X	4659330	S004	2	-25...+70	IP67	PBT	PBT	PVC 2 m	-	•
NI22U-Q40-AP6X2-H1141	4690229 ✕	S002	0.25	0...+70	IP68	PBT	PBT	-	•	•
BI20U-CA40-AP6X2-H1141	1627200 ✕	S002	0.25	0...+70	IP67	GD-AI	DURO	-	•	•
BI20U-CA40-AN6X2-H1141	1627300	S005	0.25	0...+70	IP67	GD-AI	DURO	-	•	•

✕ = 优选型号











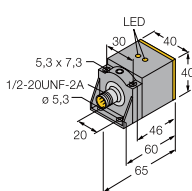



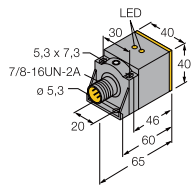



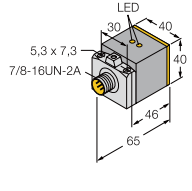



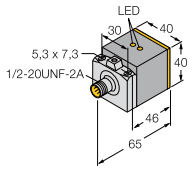



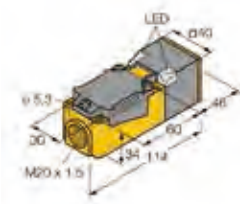







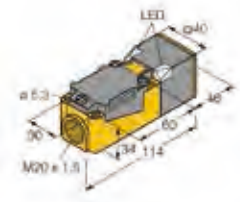



电感式传感器

尺寸/外形	特性	额定工作距离Sn [mm]	输出	工作电压	额定工作电流I _e [mA]	
	CK40 	<i>uprox</i> [®] +	20, 	—, PNP	10...30 VDC	200 DC, (K)
		<i>uprox</i> [®] +	20, 	—, PNP	10...65 VDC	200 DC, (K)
		<i>uprox</i> [®] +	20, 	—, NPN	10...30 VDC	200 DC, (K)
		<i>uprox</i> [®] +	20, 	—, NPN	10...65 VDC	200 DC, (K)
		<i>uprox</i> [®]	15, 	—, PNP	10...30 VDC	200 DC, (K)
		<i>uprox</i> [®]	15, 	—, PNP	10...65 VDC	200 DC, (K)
		<i>uprox</i> [®]	15, 	—, NPN	10...30 VDC	200 DC, (K)
		<i>uprox</i> [®]	15, 	—, NPN	10...65 VDC	200 DC, (K)
		⊕ II 2 G SIL2	15, 	NAMUR	nom. 8.2 VDC	—
		—	15, 	—, PNP	10...30 VDC	200 DC, (K)
		—	15, 	—, NPN	10...30 VDC	200 DC, (K)
		—	15, 	—, 2-wire	10...65 VDC	100 DC, (K)
		Sn +	35, 	—, PNP	10...30 VDC	200 DC, (K)
		<i>uprox</i> [®]	25, 	—, PNP	10...30 VDC	200 DC, (K)
		<i>uprox</i> [®]	25, 	—, PNP	10...65 VDC	200 DC, (K)
		<i>uprox</i> [®]	25, 	—, NPN	10...30 VDC	200 DC, (K)
		⊕ II 2 G SIL2	20, 	NAMUR	nom. 8.2 VDC	—
		—	20, 	—, PNP	10...30 VDC	200 DC, (K)
—	20, 	—, NPN	10...30 VDC	200 DC, (K)		
—	20, 	—, 2-wire	10...65 VDC	100 DC, (K)		
	CK40 	<i>uprox</i> [®] +	20, 	—, PNP	10...30 VDC	200 DC, (K)
		<i>uprox</i> [®] +	35, 	—, PNP	10...30 VDC	200 DC, (K)
		<i>uprox</i> [®] +	50, 	—, PNP	10...30 VDC	200 DC, (K)
	CK40 	<i>uprox</i> [®] +	30, 	—, PNP	10...30 VDC	200 DC, (K)
		<i>uprox</i> [®] +	30, 	—, NPN	10...30 VDC	200 DC, (K)
		<i>uprox</i> [®] +	50, 	—, PNP	10...30 VDC	200 DC, (K)
		<i>uprox</i> [®] +	50, 	—, PNP	10...65 VDC	200 DC, (K)
		⊕ II 3 G	50, 	—, PNP	10...65 VDC	200 DC, (K)
		⊕ II 3 D	50, 	—, PNP	10...65 VDC	200 DC, (K)
		<i>uprox</i> [®] +	50, 	—, NPN	10...30 VDC	200 DC, (K)
		<i>uprox</i> [®] +	50, 	—, NPN	10...65 VDC	200 DC, (K)
		<i>uprox</i> [®]	40, 	—, PNP	10...30 VDC	200 DC, (K)
		<i>uprox</i> [®]	35, 	—, PNP	10...30 VDC	200 DC, (K)
		<i>uprox</i> [®]	35, 	—, NPN	10...30 VDC	200 DC, (K)
		<i>uprox</i> [®] +	35, 	—, 2-wire	10...65 VDC	100 DC, (K)

型号	订货号	连接方式 (☞ 322)	开关频率 [kHz]	温度范围 [°C]	防护等级	外壳 (☞ 334)	感应面 (☞ 334)	导线 (☞ 334)	LED U _B	LED └
BI20U-CK40-AP6X2-H1141	1627233 ✘	S002	0.25	-30...+85	IP68	PBT	PA-X	-	•	•
BI20U-CK40-VP4X2-H1141	1627216 ✘	S008	0.25	-30...+85	IP68	PBT	PA-X	-	•	•
BI20U-CK40-AN6X2-H1141	1627231	S005	0.25	-30...+85	IP68	PBT	PA-X	-	•	•
BI20U-CK40-VN4X2-H1141	1568814	S011	0.25	-30...+85	IP68	PBT	PA-X	-	•	•
BI15U-CK40-AP6X2-H1141	1625600 ✘	S002	0.25	-30...+85	IP68	PBT	PA-X	-	•	•
BI15U-CK40-VP4X2-H1141	1568801 ✘	S008	0.25	-30...+85	IP68	PBT	PA-X	-	•	•
BI15U-CK40-AN6X2-H1141	1625610	S005	0.25	-30...+85	IP68	PBT	PA-X	-	•	•
BI15U-CK40-VN4X2-H1141	1568811	S011	0.25	-30...+85	IP68	PBT	PA-X	-	•	•
BI15-CK40-Y1X-H1141	4065000	S026	0.15	-25...+70	IP67	PBT	PA	-	-	•
BI15-CK40-AP6X2-H1141	16250 ✘	S002	0.15	-25...+70	IP67	PBT	PA	-	•	•
BI15-CK40-AN6X2-H1141	16251	S005	0.15	-25...+70	IP67	PBT	PA	-	•	•
BI15-CK40-AD4X-H1141	44650 ✘	S014	0.15	-25...+70	IP67	PBT	PA	-	-	•
NI35-CK40-AP6X2-H1141	1626400 ✘	S002	0.15	-25...+70	IP67	PBT	PA	-	•	•
NI25U-CK40-AP6X2-H1141	1625700 ✘	S002	0.25	-30...+85	IP68	PBT	PA-X	-	•	•
NI25U-CK40-VP4X2-H1141	1568803 ✘	S008	0.25	-30...+85	IP68	PBT	PA-X	-	•	•
NI25U-CK40-AN6X2-H1141	1625710	S005	0.25	-30...+85	IP68	PBT	PA-X	-	•	•
NI20-CK40-Y1X-H1141	4065200	S026	0.15	-25...+70	IP67	PBT	PA	-	-	•
NI20-CK40-AP6X2-H1141	16252 ✘	S002	0.15	-25...+70	IP67	PBT	PA	-	•	•
NI20-CK40-AN6X2-H1141	16253 ✘	S005	0.15	-25...+70	IP67	PBT	PA	-	•	•
NI20-CK40-AD4X-H1141	44652	S014	0.2	-25...+70	IP67	PBT	PA	-	-	•
BI20U-QV40-AP6X2-H1141	1627245	S002	0.25	-30...+85	IP68	PBT	PBT	-	••	••
NI35U-QV40-AP6X2-H1141	1625866	S002	0.25	-30...+85	IP68	PBT	PA-X	-	••	••
NI50U-QV40-AP6X2-H1141	1625853	S002	0.25	-30...+85	IP68	PBT	PBT	-	••	••
BI30U-CK40-AP6X2-H1141	1625829 ✘	S002	0.25	-10...+60	IP68	PBT	PA-X	-	••	••
BI30U-CK40-AN6X2-H1141	1625820	S005	0.25	-10...+60	IP68	PBT	PA-X	-	••	••
NI50U-CK40-AP6X2-H1141	1625837 ✘	S002	0.25	-30...+85	IP68	PBT	PA-X	-	••	••
NI50U-CK40-VP4X2-H1141	1538302 ✘	S008	0.25	-30...+85	IP68	PBT	PA-X	-	••	••
NI50U-CK40-VP4X2-H1141/ 3GD	1514120	S008	0.25	-30...+85	IP68	PBT	PA-X	-	••	••
NI50U-CK40-AN6X2-H1141	1625823 ✘	S005	0.25	-30...+85	IP68	PBT	PA-X	-	••	••
NI50U-CK40-VN4X2-H1141	1625806	S011	0.25	-30...+85	IP68	PBT	PA-X	-	••	••
NI40U-CK40-AP6X2-H1141	1623641 ✘	S002	0.25	-30...+85	IP68	PBT	PA-X	-	••	••
NI35U-CK40-AP6X2-H1141	1625800 ✘	S002	0.25	-30...+85	IP68	PBT	PA-X	-	••	••
NI35U-CK40-AN6X2-H1141	1625810 ✘	S005	0.25	-30...+85	IP68	PBT	PA-X	-	••	••
NI35U-CK40-AD4X-H1141	4280232	S99	0.01	-25...+70	IP68	PBT	PBT	-	••	••

✘ = 优选型号

电感式传感器











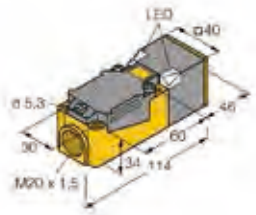













































尺寸/外形	特性	额定工作距离Sn [mm]	输出	工作电压	额定工作电流Ie [mA]	
	CK40	<i>uprox</i> [®]	35, 		20...250 VAC 10...300 VDC	400 AC 300 DC, (K)
						
	CK40	<i>uprox</i> [®]	35, 		20...250 VAC 10...300 VDC	400 AC 300 DC, (K)
						
	CK40	<i>uprox</i> [®]	15, 		20...250 VAC 10...300 VDC	400 AC 300 DC, (K)
						
	CK40	<i>uprox</i> [®]	15, 		20...250 VAC 10...300 VDC	400 AC 300 DC, (K)
						
	CP40	<i>uprox</i> [®]	15, 	 , PNP	10...65 VDC	200 DC, (K)
		<i>uprox</i> [®] +	50, 	 , PNP	10...30 VDC	200 DC, (K)
		<i>uprox</i> [®]	40, 	 , PNP	10...65 VDC	200 DC, (K)
	CP40	<i>uprox</i> [®] +	30, 	 , NPN	10...30 VDC	200 DC, (K)
		<i>uprox</i> [®] +	20, 	 , PNP	10...30 VDC	200 DC, (K)
		(K) II 3 D	20, 	 , PNP	10...30 VDC	200 DC, (K)
		<i>uprox</i> [®] +	20, 	 , NPN	10...30 VDC	200 DC, (K)
		<i>uprox</i> [®] +	20, 	 , NPN	10...65 VDC	200 DC, (K)
		<i>uprox</i> [®]	15, 	 , NPN	10...30 VDC	200 DC, (K)

型号	订货号	连接方式 (☞ 322)	开关频率 [kHz]	温度范围 [°C]	防护等级	外壳 (☞ 334)	感应面 (☞ 334)	导线 (☞ 334)	LED U _B	LED ┌
NI35U-CK40-ADZ30X2-B3131	4280430 ✘	S152	0.01	-30...+85	IP68	PBT	PA-X	-	•	•
NI35U-CK40-ADZ30X2-B1131	4280410 ✘	S152	0.01	-30...+85	IP68	PBT	PA-X	-	•	•
BI15U-CK40-ADZ30X2-B1131	4280010	S152	0.01	-30...+85	IP68	PBT	PA-X	-	•	•
BI15U-CK40-ADZ30X2-B3131	4280030 ✘	S152	0.01	-30...+85	IP68	PBT	PA-X	-	•	•
BI15U-CP40-VP4X2-H1141	1540502 ✘	S008	0.25	-30...+85	IP68	PBT	PA-X	-	•	•
NI50U-CP40-AP6X2-H1141	1625835 ✘	S002	0.25	-30...+85	IP68	PBT	PA-X	-	•	•
NI40U-CP40-VP4X2-H1141	1540602 ✘	S008	0.25	-30...+85	IP68	PBT	PA-X	-	•	•
BI30U-CP40-AN6X2	1625102	S006	0.25	-10...+60	IP68	PBT	PA-X	-	•	•
BI20U-CP40-AP6X2	1627232 ✘	S003	0.25	-30...+85	IP68	PBT	PA-X	-	•	•
BI20U-CP40-AP6X2/3D	1627236 ✘	S003	0.25	-30...+85	IP68	PBT	PA-X	-	•	•
BI20U-CP40-AN6X2	1627230	S006	0.25	-30...+85	IP68	PBT	PA-X	-	•	•
BI20U-CP40-VN4X2	1627237	S012	0.25	-30...+85	IP68	PBT	PA-X	-	•	•
BI15U-CP40-AN6X2	1623510	S006	0.25	-30...+85	IP68	PBT	PA-X	-	•	•

✘ = 优选型号

2











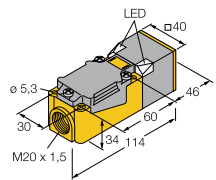







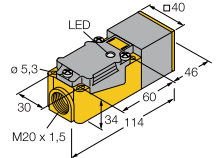







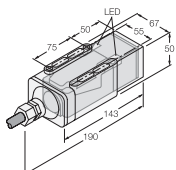

电感式传感器

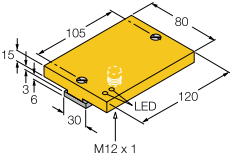
尺寸/外形	特性	额定工作距离Sn [mm]	输出	工作电压	额定工作电流Ie [mA]		
	CP40						
		<i>uprox</i> [®]	15, 	program.	20...250 VAC 10...300 VDC	400 AC 300 DC, (K)	
	-	15, 	 , PNP	10...30 VDC	200 DC, (K)		
	-	15, 	 , PNP	10...65 VDC	200 DC, (K)		
	T -40 °C	15, 	 , PNP	10...65 VDC	200 DC, (K)		
	T +100 °C	15, 	 , PNP	10...65 VDC	200 DC, (K)		
	-	15, 	 , NPN	10...30 VDC	200 DC, (K)		
	-	15, 	 , NPN	10...65 VDC	200 DC, (K)		
	-	15, 	program.	20...250 VAC 10...300 VDC	400 AC 300 DC		
	T +100 °C	15, 	program.	20...250 VAC 10...300 VDC	400 AC 300 DC		
	T -40 °C	15, 	program.	20...250 VAC 10...300 VDC	400 AC 300 DC		
	<i>uprox</i> [®] +	50, 	 , PNP	10...30 VDC	200 DC, (K)		
	<i>uprox</i> [®] +	50, 	 , PNP	10...65 VDC	200 DC, (K)		
	<i>uprox</i> [®] +	50, 	 , NPN	10...30 VDC	200 DC, (K)		
	<i>uprox</i> [®] +	50, 	 , NPN	10...65 VDC	200 DC, (K)		
	<i>uprox</i> [®]	40, 	 , PNP	10...65 VDC	200 DC, (K)		
	<i>uprox</i> [®]	40, 	 , NPN	10...65 VDC	200 DC, (K)		
	<i>uprox</i> [®]	40, 	program.	20...250 VAC 10...300 VDC	400 AC 300 DC, (K)		
	-	35, 	 , PNP	10...65 VDC	200 DC, (K)		
	-	35, 	 , NPN	10...65 VDC	200 DC, (K)		
	-	35, 	program.	20...250 VAC 10...300 VDC	400 AC 300 DC		
	-	20, 	 , PNP	10...30 VDC	200 DC, (K)		
	-	20, 	 , PNP	10...65 VDC	200 DC, (K)		
	T -40 °C	20, 	 , PNP	10...65 VDC	200 DC, (K)		
	T +100 °C	20, 	 , PNP	10...65 VDC	200 DC, (K)		
	选择型NF	20, 	 , PNP	10...65 VDC	200 DC, (K)		
	-	20, 	 , NPN	10...30 VDC	200 DC, (K)		
	-	20, 	 , NPN	10...65 VDC	200 DC, (K)		
	选择型NF	20, 	 , NPN	10...65 VDC	200 DC, (K)		
	-	20, 	program.	20...250 VAC 10...300 VDC	400 AC 300 DC		
T +100 °C	20, 	program.	20...250 VAC 10...300 VDC	400 AC 300 DC			
T -40 °C	20, 	program.	20...250 VAC 10...300 VDC	400 AC 300 DC			
选择型NF	20, 	program.	20...250 VAC	400 AC			

型号	订货号	连接方式 (☞ 322)	开关频率 [kHz]	温度范围 [°C]	防护等级	外壳 (☞ 334)	感应面 (☞ 334)	导线 (☞ 334)	LED U _B	LED ┘
BI15U-CP40-FDZ30X2	4280600 ✘	S016	0.01	-30...+85	IP68	PBT	PA-X	-	•	•
BI15-CP40-AP6X2	16023 ✘	S003	0.15	-25...+70	IP67	PBT	PBT	-	•	•
BI15-CP40-VP4X2	15690 ✘	S009	0.15	-25...+70	IP67	PBT	PBT	-	•	•
BI15-CP40-VP4X2/S97	15058 ✘	S009	0.15	-40...+70	IP67	PBT	PBT	-	•	•
BI15-CP40-VP4X2/S100	15045 ✘	S009	0.15	-25...+100	IP67	PBT	PBT	-	•	•
BI15-CP40-AN6X2	16223 ✘	S006	0.15	-25...+70	IP67	PBT	PBT	-	•	•
BI15-CP40-VN4X2	15790 ✘	S012	0.15	-25...+70	IP67	PBT	PBT	-	•	•
BI15-CP40-FZ3X2	13400 ✘	S016	0.02	-25...+70	IP67	PBT	PBT	-	•	•
BI15-CP40-FZ3X2/S100	13440 ✘	S016	0.02	-25...+100	IP67	PBT	PBT	-	•	•
BI15-CP40-FZ3X2/S97	1341015	S016	0.02	-40...+70	IP67	PBT	PBT	-	•	•
NI50U-CP40-AP6X2	1625831 ✘	S003	0.25	-30...+85	IP68	PBT	PA-X	-	•	•
NI50U-CP40-VP4X2	1538303 ✘	S009	0.25	-30...+85	IP68	PBT	PA-X	-	•	•
NI50U-CP40-AN6X2	1625846 ✘	S006	0.25	-30...+85	IP68	PBT	PA-X	-	•	•
NI50U-CP40-VN4X2	1625847	S012	0.25	-30...+85	IP68	PBT	PA-X	-	•	•
NI40U-CP40-VP4X2	1540600 ✘	S009	0.25	-30...+85	IP68	PBT	PA-X	-	•	•
NI40U-CP40-VN4X2	1540610 ✘	S012	0.25	-30...+85	IP68	PBT	PA-X	-	•	•
NI40U-CP40-FDZ30X2	4280800 ✘	S016	0.02	-30...+85	IP68	PBT	PA-X	-	•	•
NI35-CP40-VP4X2	15694 ✘	S009	0.15	-25...+70	IP67	PBT	PBT	-	•	•
NI35-CP40-VN4X2	15794 ✘	S012	0.15	-25...+70	IP67	PBT	PBT	-	•	•
NI35-CP40-FZ3X2	13403 ✘	S016	0.02	-25...+70	IP67	PBT	PBT	-	•	•
NI20-CP40-AP6X2	16024 ✘	S003	0.15	-25...+70	IP67	PBT	PBT	-	•	•
NI20-CP40-VP4X2	15691 ✘	S009	0.15	-25...+70	IP67	PBT	PBT	-	•	•
NI20-CP40-VP4X2/S97	1569101	S009	0.15	-40...+70	IP67	PBT	PBT	-	•	•
NI20-CP40-VP4X2/S100	15046 ✘	S009	0.15	-25...+100	IP67	PBT	PBT	-	•	•
NI20NF-CP40-VP4X2	15684 ✘	S009	0.1	0...+60	IP67	PBT	PBT	-	•	•
NI20-CP40-AN6X2	16224 ✘	S006	0.15	-25...+70	IP67	PBT	PBT	-	•	•
NI20-CP40-VN4X2	15791 ✘	S012	0.15	-25...+70	IP67	PBT	PBT	-	•	•
NI20NF-CP40-VN4X2	15784 ✘	S012	0.1	0...+60	IP67	PBT	PBT	-	•	•
NI20-CP40-FZ3X2	13401 ✘	S016	0.02	-25...+70	IP67	PBT	PBT	-	•	•
NI20-CP40-FZ3X2/S100	13441 ✘	S016	0.02	-25...+100	IP67	PBT	PBT	-	•	•
NI20-CP40-FZ3X2/S97	1340123	S016	0.02	-40...+70	IP67	PBT	PBT	-	•	•
NI20NF-CP40-FZ3X2	13284 ✘	S016	0.02	0...+60	IP67	PBT	PBT	-	•	•

✘ = 优选型号











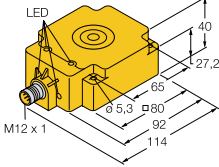







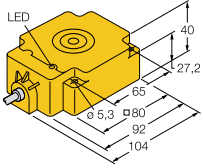



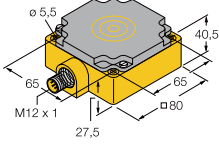



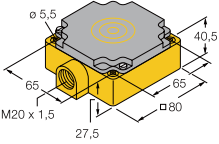

电感式传感器

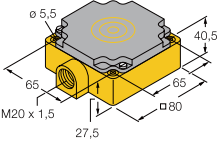
尺寸/外形	特性	额定工作距离Sn [mm]	输出	工作电压	额定工作电流I _e [mA]	
	CP40	<i>uprox</i> [®] +	30, 	—, PNP	10...30 VDC	200 DC, (K)
		<i>uprox</i> [®] +	20, 	—, PNP	10...65 VDC	200 DC, (K)
		<i>uprox</i> [®]	15, 	—, PNP	10...65 VDC	200 DC, (K)
		<i>uprox</i> [®]	15, 	—, PNP	10...30 VDC	200 DC, (K)
		<i>uprox</i> [®] , Sn+	40, 	—, NPN	10...30 VDC	200 DC, (K)
		<i>uprox</i> [®] , Sn+	40, 	—, PNP	10...30 VDC	200 DC, (K)
	CP40	⊕ II 2 G SIL2	15, 	NAMUR	nom. 8.2 VDC	—
		⊕ II 2 G ID	20, 	NAMUR	nom. 8.2 VDC	—
		⊕ II 2 G SIL2 T -40 °C	15, 	NAMUR	nom. 8.2 VDC	—
		⊕ II 2 G SIL2 T +100 °C	15, 	NAMUR	nom. 8.2 VDC	—
		—	15, 	—, 2-wire	10...65 VDC	100 DC, (K)
		⊕ II 2 G SIL2	20, 	NAMUR	nom. 8.2 VDC	—
		⊕ II 2 G SIL2 T -40 °C	20, 	NAMUR	nom. 8.2 VDC	—
		⊕ II 2 G SIL2 T +100 °C	20, 	NAMUR	nom. 8.2 VDC	—
		—	20, 	—, 2-wire	10...65 VDC	100 DC, (K)
	—	35, 	—, PNP	10...65 VDC	200 DC, (K)	
	QF15	—	30, 	—, PNP	10...30 VDC	200 DC, (K)
	Q80	<i>uprox</i> [®] +	50, 	—, PNP	10...30 VDC	200 DC, (K)
		<i>uprox</i> [®] +	50, 	—, PNP	10...65 VDC	200 DC, (K)
		⊕ II 3 G	50, 	—, PNP	10...65 VDC	200 DC, (K)
		⊕ II 3 D	50, 	—, PNP	10...65 VDC	200 DC, (K)
		<i>uprox</i> [®] +	50, 	—, NPN	10...30 VDC	200 DC, (K)
		<i>uprox</i> [®] +	50, 	—, NPN	10...65 VDC	200 DC, (K)
		<i>uprox</i> [®] +	50, 	—, NPN	10...65 VDC	200 DC, (K)

型号	订货号	连接方式 (☞ 322)	开关频率 [kHz]	温度范围 [°C]	防护等级	外壳 (☞ 334)	感应面 (☞ 334)	导线 (☞ 334)	LED	LED
									U _B	┘
BI30U-CP40-AP6X2	1625830 ✘	S003	0.25	-10...+60	IP68	PBT	PA-X	-	●●	●●
BI20U-CP40-VP4X2	1627240 ✘	S009	0.25	-30...+85	IP68	PBT	PA-X	-	●●	●●
BI15U-CP40-VP4X2	1540500 ✘	S009	0.25	-30...+85	IP68	PBT	PA-X	-	●●	●●
BI15U-CP40-AP6X2	1623500 ✘	S003	0.25	-30...+85	IP68	PBT	PA-X	-	●●	●●
NI40U-CP40-AN6X2	1623610	S006	0.25	-30...+85	IP68	PBT	PBT	-	●●	●●
NI40U-CP40-AP6X2	1623600	S003	0.25	-30...+85	IP68	PBT	PBT	-	●●	●●
BI15-CP40-Y1X	10110 ✘	S027	0.15	-25...+70	IP67	PBT	PBT	-	-	●
BI20-CP40-Y1X	1011123 ✘	S027	0.15	-25...+70	IP67	PBT	PBT	-	-	●
BI15-CP40-Y1X/S97	10397	S027	0.15	-40...+70	IP67	PBT	PBT	-	-	●
BI15-CP40-Y1X/S100	10396	S027	0.15	-25...+100	IP67	PBT	PBT	-	-	●
BI15-CP40-AD4X	44660 ✘	S015	0.15	-25...+70	IP67	PBT	PBT	-	-	●
NI20-CP40-Y1X	10111 ✘	S027	0.15	-25...+70	IP67	PBT	PBT	-	-	●
NI20-CP40-Y1X/S97	10432	S027	0.15	-40...+70	IP67	PBT	PBT	-	-	●
NI20-CP40-Y1X/S100	1011121	S027	0.15	-25...+100	IP67	PBT	PBT	-	-	●
NI20-CP40-AD4X	44661 ✘	S015	0.15	-25...+70	IP67	PBT	PBT	-	-	●
NI35-CP40-VP4X2/S938-F/S1194 30M	1569432 ✘	S007	0.15	-25...+70	IP67	Ultem	Ultem	PUR 30m	●	●
BI30-QF15-AP6X2-H1141	1625100 ✘	S002	0.25	-25...+70	IP68	PBT	PBT	-	●	●
BI50U-Q80-AP6X2-H1141	1608940 ✘	S002	0.25	-25...+70	IP68	PBT	PBT	-	●	●
BI50U-Q80-VP4X2-H1141	1562000 ✘	S008	0.25	-25...+70	IP68	PBT	PBT	-	●	●
BI50U-Q80-VP4X2-H1141/3GD	1562004	S008	0.25	-20...+70	IP68	PBT	PBT	-	●	●
BI50U-Q80-AN6X2-H1141	1608944	S005	0.25	-25...+70	IP68	PBT	PBT	-	●	●
BI50U-Q80-VN4X2-H1141	1562001	S011	0.25	-25...+70	IP68	PBT	PBT	-	●	●

✘ = 优选型号











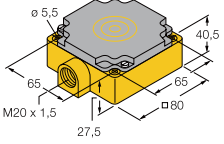



























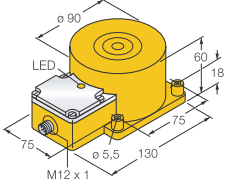





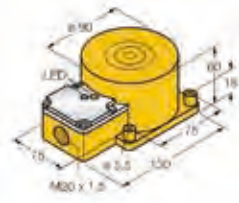





电感式传感器

尺寸/外形	特性	额定工作 距离Sn [mm]	输出	工作电压	额定工作 电流I _e [mA]	
	Q80 	<i>uprox</i> [®] + 70, 	—, PNP	10...30 VDC	200 DC, (K)	
		<i>uprox</i> [®] + 75, 	—, PNP	10...30 VDC	200 DC, (K)	
		<i>uprox</i> [®] + 70, 	—, PNP	10...65 VDC	200 DC, (K)	
		<i>uprox</i> [®] + 75, 	—, PNP	10...65 VDC	200 DC, (K)	
		<i>uprox</i> [®] + 75, 	—, NPN	10...30 VDC	200 DC, (K)	
		<i>uprox</i> [®] + 75, 	—, NPN	10...65 VDC	200 DC, (K)	
	Q80 	⊕ II 2 G SIL2 Sn + 50, 	NAMUR	nom. 8.2 VDC	—	
		⊕ II 2 G SIL2 60, 	NAMUR	nom. 8.2 VDC	—	
	CP80 	— 40, 	—, PNP	10...65 VDC	200 DC, (K)	
		<i>uprox</i> [®] 75, 	—, PNP	10...65 VDC	200 DC, (K)	
	CP80 	⊕ II 2 G SIL2 40, 	NAMUR	nom. 8.2 VDC	—	
		⊕ II 2 G SIL2 40, 	NAMUR	nom. 8.2 VDC	—	
		T -40 °C ⊕ II 2 G SIL2 40, 	NAMUR	nom. 8.2 VDC	—	
		T +100 °C				
	CP80 	— 40, 	—, PNP	10...65 VDC	200 DC, (K)	
		— 40, 	—, NPN	10...65 VDC	200 DC, (K)	
		— 40, 	program.	20...250 VAC 10...300 VDC	400 AC 300 DC	
		<i>uprox</i> [®] 75, 	—, PNP	10...30 VDC	200 DC, (K)	
		<i>uprox</i> [®] 75, 	—, PNP	10...65 VDC	200 DC, (K)	
		<i>uprox</i> [®] 75, 	—, NPN	10...30 VDC	200 DC, (K)	

型号	订货号	连接方式 (☞ 322)	开关频率 [kHz]	温度范围 [°C]	防护等级	外壳 (☞ 334)	感应面 (☞ 334)	导线 (☞ 334)	LED U _B	LED ┘
NI70U-Q80-AP6X2-H1141	1625832 ✘	S002	0.25	-25...+70	IP68	PBT	PBT	-	•	•
NI75U-Q80-AP6X2-H1141	1625855 ✘	S002	0.25	-25...+70	IP68	PBT	PBT	-	•	•
NI70U-Q80-VP4X2-H1141	1625833 ✘	S008	0.25	-25...+70	IP68	PBT	PBT	-	•	•
NI75U-Q80-VP4X2-H1141	1625857 ✘	S008	0.25	-25...+70	IP68	PBT	PBT	-	•	•
NI75U-Q80-AN6X2-H1141	1625856 ✘	S005	0.25	-25...+70	IP68	PBT	PBT	-	•	•
NI75U-Q80-VN4X2-H1141	1625858 ✘	S011	0.25	-25...+70	IP68	PBT	PBT	-	•	•
BI50-Q80-Y1X	1008701 ✘	S025	0.1	-25...+70	IP67	PBT	PBT	PVC 2 m	-	•
NI60-Q80-Y1X	1008700	S025	0.1	-25...+70	IP67	PBT	PBT	PVC 2 m	-	•
BI40-CP80-VP4X2-H1141	1569702 ✘	S008	0.1	-25...+70	IP67	PBT	PBT	-	•	•
NI75U-CP80-VP4X2-H1141	1540802	S008	0.25	-30...+85	IP67	PBT	PBT	-	•	•
NI40-CP80-Y1	10085 ✘	S027	0.1	-25...+70	IP67	PBT	PBT	-	-	-
NI40-CP80-Y1/S97	1040010	S027	0.1	-40...+70	IP67	PBT	PBT	-	-	-
NI40-CP80-Y1/S100	10404 ✘	S027	0.1	-25...+100	IP67	PBT	PBT	-	-	-
BI40-CP80-VP4X2	15697 ✘	S009	0.1	-25...+70	IP67	PBT	PBT	-	•	•
BI40-CP80-VN4X2	15797	S012	0.1	-25...+70	IP67	PBT	PBT	-	•	•
BI40-CP80-FZ3X2	13404	S016	0.01	-25...+70	IP67	PBT	PBT	-	•	•
NI75U-CP80-AP6X2	1623800 ✘	S003	0.25	-30...+85	IP67	PBT	PBT	-	•	•
NI75U-CP80-VP4X2	1540800 ✘	S009	0.25	-30...+85	IP67	PBT	PBT	-	•	•
NI75U-CP80-AN6X2	1623810 ✘	S006	0.25	-30...+85	IP67	PBT	PBT	-	•	•

✘ = 优选型号

电感式传感器











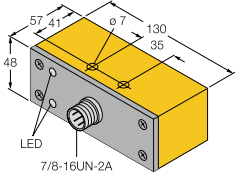



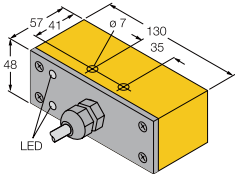







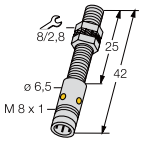







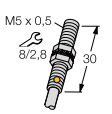







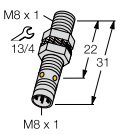









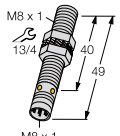





尺寸/外形		特性	额定工作距离Sn [mm]	输出	工作电压	额定工作电流I _e [mA]
	CP80 	<i>uprox</i> [®]	75, 	 , NPN	10...65 VDC	200 DC, 
		<i>uprox</i> [®]	75, 	program.	20...250 VAC 10...300 VDC	400 AC 300 DC, 
		Sn +	50, 	 , PNP	10...65 VDC	200 DC, 
		Sn +	50, 	 , NPN	10...65 VDC	200 DC, 
		Sn +	50, 	program.	20...250 VAC 10...300 VDC	400 AC 300 DC
		-	40, 	 , PNP	10...65 VDC	200 DC, 
		T -40 °C	40, 	 , PNP	10...65 VDC	200 DC, 
		T +100 °C	40, 	 , PNP	10...65 VDC	200 DC, 
		-	40, 	 , NPN	10...65 VDC	200 DC, 
		-	40, 	program.	20...250 VAC 10...300 VDC	400 AC 300 DC
		T -40 °C	40, 	program.	20...250 VAC 10...300 VDC	400 AC 300 DC
		T +100 °C	40, 	program.	20...250 VAC 10...300 VDC	400 AC 300 DC
			K90 	<i>uprox</i> [®] +	100, 	 , PNP
<i>uprox</i> [®] +	100, 			 , NPN	10...65 VDC	200 DC, 
	K90 	<i>uprox</i> [®] +	100, 	 , PNP	10...65 VDC	200 DC, 
		<i>uprox</i> [®] +	100, 	 , NPN	10...65 VDC	200 DC, 
		-	60, 	 , PNP	10...65 VDC	200 DC, 
		-	60, 	 , NPN	10...65 VDC	200 DC, 
		-	60, 	program.	20...250 VAC 10...300 VDC	400 AC 300 DC
		 II 2 G SIL2	50, 	NAMUR	nom. 8.2 VDC	-

型号	订货号	连接方式 (☞ 322)	开关频率 [kHz]	温度范围 [°C]	防护等级	外壳 (☞ 334)	感应面 (☞ 334)	导线 (☞ 334)	LED U _B	LED ┘
NI75U-CP80-VN4X2	1540810 ✕	S012	0.25	-30...+85	IP67	PBT	PBT	-	•	•
NI75U-CP80-FDZ30X2	4280900 ✕	S016	0.01	-30...+85	IP67	PBT	PBT	-	•	•
NI50-CP80-VP4X2	15696 ✕	S009	0.1	-25...+70	IP67	PBT	PBT	-	•	•
NI50-CP80-VN4X2	15796 ✕	S012	0.1	-25...+70	IP67	PBT	PBT	-	•	•
NI50-CP80-FZ3X2	13406 ✕	S016	0.01	-25...+70	IP67	PBT	PBT	-	•	•
NI40-CP80-VP4X2	15695 ✕	S009	0.1	-25...+70	IP67	PBT	PBT	-	•	•
NI40-CP80-VP4X2/S97	1569522	S009	0.1	-40...+70	IP67	PBT	PBT	-	•	•
NI40-CP80-VP4X2/S100	15095 ✕	S009	0.1	-25...+100	IP67	PBT	PBT	-	•	•
NI40-CP80-VN4X2	15795 ✕	S012	0.1	-25...+70	IP67	PBT	PBT	-	•	•
NI40-CP80-FZ3X2	13405 ✕	S016	0.01	-25...+70	IP67	PBT	PBT	-	•	•
NI40-CP80-FZ3X2/S97	1340510	S016	0.01	-40...+70	IP67	PBT	PBT	-	•	•
NI40-CP80-FZ3X2/S100	13443 ✕	S016	0.01	-25...+100	IP67	PBT	PBT	-	•	•
NI100U-K90SR-VP4X2-H1141	1625844	S008	0.25	-30...+85	IP68	PBT	PBT	-	•	•
NI100U-K90SR-VN4X2-H1141	1515510	S011	0.25	-30...+85	IP68	PBT	PBT	-	•	•
NI100U-K90SR-VP4X2	1625834 ✕	S009	0.25	-30...+85	IP68	PBT	PBT	-	•	•
NI100U-K90SR-VN4X2	1515503 ✕	S012	0.25	-30...+85	IP68	PBT	PBT	-	•	•
NI60-K90SR-VP4X2	15640 ✕	S009	0.06	-25...+70	IP67	PBT	PBT	-	•	•
NI60-K90SR-VN4X2	15740 ✕	S012	0.06	-25...+70	IP67	PBT	PBT	-	•	•
NI60-K90SR-FZ3X2	13429 ✕	S016	0.02	-25...+70	IP67	PBT	PBT	-	•	•
NI50-K90SR-Y1	10074 ✕	S027	0.1	-25...+70	IP67	PBT	PBT	-	-	-

✕ = 优选型号

2











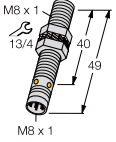











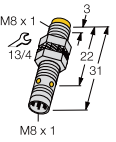





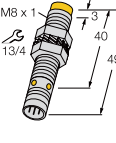

















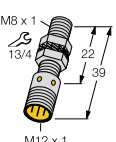













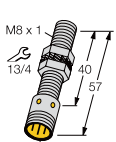





电感式传感器

尺寸/外形	特性	额定工作距离Sn [mm]	输出	工作电压	额定工作电流I _e [mA]
	Q130	-	-	20...250 VAC 10...300 VDC	400 AC 300 DC, (K)
		30, 			
	Q130	-	-	10...65 VDC	200 DC, (K)
		30, 	 , PNP	10...65 VDC	200 DC, (K)
	-	30, 	 , NPN	10...65 VDC	200 DC, (K)
	-	30, 		20...250 VAC 10...300 VDC	400 AC 300 DC, (K)
	M5 x 0,5	-	-	10...30 VDC	100 DC, (K)
		1, 	 , PNP	10...30 VDC	100 DC, (K)
	-	1, 	 , NPN	10...30 VDC	100 DC, (K)
	-	1, 		10...30 VDC	100 DC, (K)
	M5 x 0,5	 II 2 G SIL2	-	NAMUR	nom. 8.2 VDC
		1, 	 , PNP	10...30 VDC	100 DC, (K)
	-	1, 	 , PNP	10...30 VDC	100 DC, (K)
	-	1, 		10...30 VDC	100 DC, (K)
	M8 x 1	Sn +	2, 	 , PNP	10...30 VDC
		Sn +	2, 		10...30 VDC
	-	1.5, 		10...30 VDC	150 DC, (K)
	-	1.5, 		10...30 VDC	150 DC, (K)
	M8 x 1	<i>uprox</i> [®] +	2, 		10...30 VDC
		PTFE	2, 		10...30 VDC
	-	<i>uprox</i> [®] +	2, 		10...30 VDC
	-	<i>uprox</i> [®] +	2, 		10...30 VDC
	-	<i>uprox</i> [®] +	2, 		10...30 VDC
	-	Sn +	2, 		10...30 VDC
	-	2, 		10...30 VDC	150 DC, (K)

型号	订货号	连接方式 (☞ 322)	开关频率 [kHz]	温度范围 [°C]	防护等级	外壳 (☞ 334)	感应面 (☞ 334)	导线 (☞ 334)	LED U _B	LED ┘
NI30-Q130-ADZ30X2-B1131	42100 ✘	S153	0.03	-25...+70	IP67	PBT	PBT	-	•	•
NI30-Q130-VP4X2	15179 ✘	S007	0.06	-25...+70	IP67	PBT	PBT	PVC 2 m	•	•
NI30-Q130-VN4X2	15178	S010	0.06	-25...+70	IP67	PBT	PBT	PVC 2 m	•	•
NI30-Q130-ADZ30X2	42095 ✘	S155	0.06	-25...+70	IP67	PBT	PBT	PVC 2 m	•	•
BI1-EG05-AP6X-V1331	4608640 ✘	S002	3	-25...+70	IP67	VA	PA	-	-	•
BI1-EG05-RP6X-V1331	4609752	S175	3	-25...+70	IP67	VA	PA	-	-	•
BI1-EG05-AN6X-V1331	4608740 ✘	S005	3	-25...+70	IP67	VA	PA	-	-	•
BI1-EG05-Y1	1003240 ✘	S025	5	-25...+70	IP67	VA	PA	PVC 2 m	-	-
BI1-EG05-AP6X	4609740 ✘	S001	3	-25...+70	IP67	VA	PA	PUR 2 m	-	•
BI1-EG05-RP6X	4609750	S054	3	-25...+70	IP67	VA	PA	PUR 2 m	-	•
BI1-EG05-AN6X	4609840 ✘	S004	3	-25...+70	IP67	VA	PA	PUR 2 m	-	•
BI2-EG08K-AP6X-V1131	4669450 ✘	S002	3	-25...+70	IP67	VA	PA	-	-	•
BI2-EG08K-AN6X-V1131	4669550 ✘	S005	3	-25...+70	IP67	VA	PA	-	-	•
BI1,5-EG08K-AP6X-V1131	4672440 ✘	S002	3	-25...+70	IP67	VA	PA	-	-	•
BI1,5-EG08K-AN6X-V1131	4672540 ✘	S005	3	-25...+70	IP67	VA	PA	-	-	•
BI2U-EG08-AP6X-V1131	4602033 ✘	S002	2	-30...+85	IP68	VA	PA	-	-	•
BI2U-EGT08-AP6X-V1131	4602070 ✘	S002	2	-30...+85	IP68	VA-T	PA	-	-	•
BI2U-EG08-RP6X-V1131	4602091 ✘	S175	2	-30...+85	IP68	VA	PA	-	-	•
BI2U-EG08-AN6X-V1131	4602036	S005	2	-30...+85	IP68	VA	PA	-	-	•
BI2-EG08-AP6X-V1131	4602050 ✘	S002	3	-25...+70	IP67	VA	PA	-	-	•
BI2-EG08-AN6X-V1131	4602150 ✘	S005	3	-25...+70	IP67	VA	PA	-	-	•

✘ = 优选型号

电感式传感器

























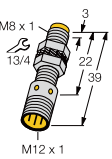



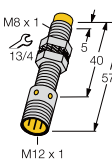











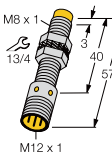

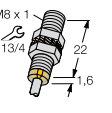

尺寸/外形	特性	额定工作距离 S_n [mm]	输出	工作电压	额定工作电流 I_e [mA]	
	M8 x 1	<i>uprox</i> [®]	1.5, 	 , PNP	10...30 VDC	150 DC, (K)
		PTFE <i>uprox</i> [®]	1.5, 	 , PNP	10...30 VDC	150 DC, (K)
		<i>uprox</i> [®]	1.5, 	 , NPN	10...30 VDC	150 DC, (K)
		-	1.5, 	 , PNP	10...30 VDC	150 DC, (K)
		-	1.5, 	 , NPN	10...30 VDC	150 DC, (K)
	M8 x 1	-	3, 	 , PNP	10...30 VDC	150 DC, (K)
		-	3, 	 , NPN	10...30 VDC	150 DC, (K)
	M8 x 1	-	3, 	 , PNP	10...30 VDC	150 DC, (K)
		-	3, 	 , NPN	10...30 VDC	150 DC, (K)
	M8 x 1	<i>uprox</i> [®] +	6, 	 , PNP	10...30 VDC	150 DC, (K)
		<i>uprox</i> [®] +	6, 	 , PNP	10...30 VDC	150 DC, (K)
		<i>uprox</i> [®] +	6, 	 , NPN	10...30 VDC	150 DC, (K)
		<i>uprox</i> [®]	4, 	 , PNP	10...30 VDC	150 DC, (K)
		<i>uprox</i> [®]	4, 	 , NPN	10...30 VDC	150 DC, (K)
	M8 x 1	Sn +	2, 	 , PNP	10...30 VDC	150 DC, (K)
		Sn +	2, 	 , PNP	10...30 VDC	150 DC, (K)
		Sn +	2, 	 , NPN	10...30 VDC	150 DC, (K)
		Sn +	2, 	 , NPN	10...30 VDC	200 DC, (K)
		⊕ II 2 G SIL2	1.5, 	NAMUR	nom. 8.2 VDC	-
		-	1.5, 	 , PNP	10...30 VDC	150 DC, (K)
		-	1.5, 	 , NPN	10...30 VDC	150 DC, (K)
	M8 x 1	<i>uprox</i> [®] +	2, 	 , PNP	10...30 VDC	150 DC, (K)
		PTFE <i>uprox</i> [®] +	2, 	 , PNP	10...30 VDC	150 DC, (K)
		⊕ II 1G, ID	1.5, 	NAMUR	Nom, 8.2 VDC	-
		<i>uprox</i> [®] +	2, 	 , PNP	10...30 VDC	150 DC, (K)
		<i>uprox</i> [®] +	2, 	 , NPN	10...30 VDC	150 DC, (K)
		Sn +	2, 	 , PNP	10...30 VDC	150 DC, (K)
		Sn +	2, 	 , PNP	10...30 VDC	150 DC, (K)
		PTFE <i>uprox</i> [®] +	1.5, 	 , NPN	10...30 VDC	150 DC, (K)

型号	订货号	连接方式 (☞ 322)	开关频率 [kHz]	温度范围 [°C]	防护等级	外壳 (☞ 334)	感应面 (☞ 334)	导线 (☞ 334)	LED U _B	LED ┌
BI1,5U-EG08-AP6X-V1131	4600520 ✕	S002	2	-30...+85	IP68	VA	PA	-	-	•
BI1,5U-EGT08-AP6X-V1131	4600556 ✕	S002	2	-30...+85	IP67	VA-T	PA	-	-	•
BI1,5U-EG08-AN6X-V1131	4600530 ✕	S005	2	-30...+85	IP68	VA	PA	-	-	•
BI1,5-EG08-AP6X-V1131	4602220 ✕	S002	3	-25...+70	IP67	VA	PA	-	-	•
BI1,5-EG08-AN6X-V1131	4602350	S005	3	-25...+70	IP67	VA	PA	-	-	•
NI3-EG08K-AP6X-V1131	4669650 ✕	S002	3	-25...+70	IP67	VA	PA	-	-	•
NI3-EG08K-AN6X-V1131	4669750	S005	3	-25...+70	IP67	VA	PA	-	-	•
NI3-EG08-AP6X-V1131	4602750 ✕	S002	3	-25...+70	IP67	VA	PA	-	-	•
NI3-EG08-AN6X-V1131	4602850	S005	3	-25...+70	IP67	VA	PA	-	-	•
NI6U-EG08-AP6X-V1131	4635801 ✕	S002	1	-25...+70	IP68	VA	PA	-	-	•
NI6U-EG08-RP6X-V1131	4635831 ✕	S175	1	-25...+70	IP68	VA	PA	-	-	•
NI6U-EG08-AN6X-V1131	4635804	S005	1	-25...+70	IP68	VA	PA	-	-	•
NI4U-EG08-AP6X-V1131	4600620 ✕	S002	2	-30...+85	IP68	VA	PA	-	-	•
NI4U-EG08-AN6X-V1131	4600630 ✕	S005	2	-30...+85	IP68	VA	PA	-	-	•
BI2-EG08K-AP6X-H1341	4669460 ✕	S002	3	-25...+70	IP67	VA	PA	-	-	•
BI2-EG08K-VP6X-H1341	4669416 ✕	S002	3	-25...+70	IP67	V4A	PP	-	-	•
BI2-EG08K-AN6X-H1341	4669560	S005	3	-25...+70	IP67	VA	PA	-	-	•
BI2-EG08K-VN6X-H1341	4669419	S005	3	-25...+70	IP67	V4A	PP	-	-	•
BI1,5-EG08K-Y1-H1341	1003620 ✕	S026	5	-25...+70	IP67	VA	PA	-	-	-
BI1,5-EG08K-AP6X-H1341	4669050 ✕	S002	3	-25...+70	IP67	VA	PA	-	-	•
BI1,5-EG08K-AN6X-H1341	4669150 ✕	S005	3	-25...+70	IP67	VA	PA	-	-	•
BI2U-EG08-AP6X-H1341	4602034 ✕	S002	2	-30...+85	IP68	VA	PA	-	-	•
BI2U-EGT08-AP6X-H1341	4602071 ✕	S002	2	-30...+85	IP68	VA-T	PA	-	-	•
BI1,5-EG08-Y1-H1341	1003502	S026	5	-25...+70	IP67	V4A(1.4404)	PP-GF30	-	-	-
BI2U-EG08-RP6X-H1341	4602080 ✕	S056	2	-30...+85	IP68	VA	PA	-	-	•
BI2U-EG08-AN6X-H1341	4602037	S005	2	-30...+85	IP68	VA	PA	-	-	•
BI2-EG08-AP6X-H1341	4602060 ✕	S002	3	-25...+70	IP67	VA	PA	-	-	•
BI2-EG08-VP6X-H1341	4602522 ✕	S008	2	-25...+70	IP67	VA	PA	-	-	•
BI1,5U-EGT08-AN6X-H1341	4600558	S026	2	-30...+85	IP68	V2A(1.4301)	PP-GF30	-	-	•

✕ = 优选型号

2











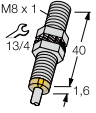















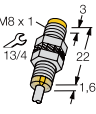

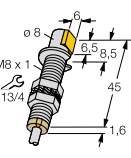

电感式传感器

尺寸/外形	特性	额定工作距离Sn [mm]	输出	工作电压	额定工作电流I _e [mA]	
	M8 x 1 	Sn +	2, 	 , NPN	10...30 VDC	150 DC, (K)
		Sn +	2, 	 , 2-wire	10...55 VDC	100 DC, (K)
		<i>uprox</i> [®]	1.5, 	 , PNP	10...30 VDC	150 DC, (K)
		PTFE <i>uprox</i> [®]	1.5, 	 , PNP	10...30 VDC	150 DC, (K)
		<i>uprox</i> [®]	1.5, 	 , NPN	10...30 VDC	150 DC, (K)
		20 bar wash down	1.5, 	 , PNP	10...30 VDC	150 DC, (K)
		-	1.5, 	 , PNP	10...30 VDC	150 DC, (K)
		20 bar wash down	1.5, 	 , NPN	10...30 VDC	150 DC, (K)
		-	1.5, 	 , NPN	10...30 VDC	150 DC, (K)
	M8 x 1 	⊕ II 2 G SIL2	3, 	NAMUR	nom. 8.2 VDC	-
		-	3, 	 , PNP	10...30 VDC	150 DC, (K)
		-	3, 	 , NPN	10...30 VDC	150 DC, (K)
	M8 x 1 	<i>uprox</i> [®] +	6, 	 , PNP	10...30 VDC	150 DC, (K)
		<i>uprox</i> [®] +	6, 	 , PNP	10...30 VDC	150 DC, (K)
		<i>uprox</i> [®] +	6, 	 , PNP	10...30 VDC	150 DC, (K)
		<i>uprox</i> [®] +	6, 	 , NPN	10...30 VDC	150 DC, (K)
		<i>uprox</i> [®]	4, 	 , PNP	10...30 VDC	150 DC, (K)
		<i>uprox</i> [®]	4, 	 , NPN	10...30 VDC	150 DC, (K)
	M8 x 1 	-	3, 	 , PNP	10...30 VDC	150 DC, (K)
		-	3, 	 , NPN	10...30 VDC	150 DC, (K)
	M8 x 1 	Sn +	2, 	 , PNP	10...30 VDC	150 DC, (K)
		Sn +	2, 	 , NPN	10...30 VDC	150 DC, (K)
		⊕ II 2 G SIL2	1.5, 	NAMUR	nom. 8.2 VDC	-
		-	1.5, 	 , PNP	10...30 VDC	150 DC, (K)
		-	1.5, 	 , NPN	10...30 VDC	150 DC, (K)

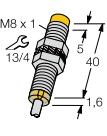
型号	订货号	连接方式 (☞ 322)	开关频率 [kHz]	温度范围 [°C]	防护等级	外壳 (☞ 334)	感应面 (☞ 334)	导线 (☞ 334)	LED U _B	LED ┘
BI2-EG08-AN6X-H1341	4602160 ✕	S005	3	-25...+70	IP67	VA	PA	-	-	•
BI2-EG08-AG41X-H1341	4562001	S093	1	-25...+70	IP67	VA	PA	-	-	•
BI1,5U-EG08-AP6X-H1341	4600540 ✕	S002	2	-30...+85	IP68	VA	PA	-	-	•
BI1,5U-EGT08-AP6X-H1341	4600555 ✕	S002	2	-30...+85	IP68	VA-T	PA	-	-	•
BI1,5U-EG08-AN6X-H1341	4600550	S005	2	-30...+85	IP68	VA	PA	-	-	•
BI1,5-EG08WD-AP6X-H1341	4602210 ✕	S002	3	-25...+85	IP68 / IP69K	VA	PVDF	-	-	•
BI1,5-EG08-AP6X-H1341	4602260 ✕	S002	3	-25...+70	IP67	VA	PA	-	-	•
BI1,5-EG08WD-AN6X-H1341	4602211	S005	3	-25...+85	IP68 / IP69K	VA	PVDF	-	-	•
BI1,5-EG08-AN6X-H1341	4602360 ✕	S005	3	-25...+70	IP67	VA	PA	-	-	•
NI3-EG08K-Y1-H1341	1003720 ✕	S026	5	-25...+70	IP67	VA	PA	-	-	-
NI3-EG08K-AP6X-H1341	4669660 ✕	S002	3	-25...+70	IP67	VA	PA	-	-	•
NI3-EG08K-AN6X-H1341	4669760 ✕	S005	3	-25...+70	IP67	VA	PA	-	-	•
NI6U-EG08-AP6X-H1341	4635802 ✕	S002	1	-25...+70	IP68	VA	PA	-	-	•
NI6U-EGT08-AP6X-H1341	4635811 ✕	S002	1	-25...+70	IP68	V2A-T	PP	-	-	•
NI6U-EG08-RP6X-H1341	4635830 ✕	S056	1	-25...+70	IP68	VA	PA	-	-	•
NI6U-EG08-AN6X-H1341	4635805	S005	1	-25...+70	IP68	VA	PA	-	-	•
NI4U-EG08-AP6X-H1341	4600640 ✕	S002	2	-30...+85	IP68	VA	PA	-	-	•
NI4U-EG08-AN6X-H1341	4600650	S005	2	-30...+85	IP68	VA	PA	-	-	•
NI3-EG08-AP6X-H1341	4602760 ✕	S002	3	-25...+70	IP67	VA	PA	-	-	•
NI3-EG08-AN6X-H1341	4602860 ✕	S005	3	-25...+70	IP67	VA	PA	-	-	•
BI2-EG08K-AP6X	4669400 ✕	S001	3	-25...+70	IP67	VA	PA	PUR 2 m	-	•
BI2-EG08K-AN6X	4669500 ✕	S004	3	-25...+70	IP67	VA	PA	PUR 2 m	-	•
BI1,5-EG08K-Y1	1003600 ✕	S025	5	-25...+70	IP67	VA	PA	PVC 2 m	-	-
BI1,5-EG08K-AP6X	4669040 ✕	S001	3	-25...+70	IP67	VA	PA	PUR 2 m	-	•
BI1,5-EG08K-AN6X	4669140 ✕	S004	3	-25...+70	IP67	VA	PA	PUR 2 m	-	•

✕ = 优选型号

电感式传感器

尺寸/外形	特性	额定工作距离Sn [mm]	输出	工作电压	额定工作电流I _e [mA]	
	M8 x 1 	<i>uprox</i> [®] +	2, 	—, PNP	10...30 VDC	150 DC, (K)
		<i>uprox</i> [®] +	2, 	—, NPN	10...30 VDC	150 DC, (K)
		Sn +	2, 	—, PNP	10...30 VDC	150 DC, (K)
		T +100 °C	2, 	—, PNP	10...30 VDC	150 DC, (K)
		Sn +	2, 	—, NPN	10...30 VDC	150 DC, (K)
		T +100 °C	2, 	—, NPN	10...30 VDC	150 DC, (K)
		Sn +	2, 	—, 2-wire	10...55 VDC	100 DC, (K)
		-	2, 	—	20...132 VAC 10...140 VDC	100 AC 100 DC
		<i>uprox</i> [®]	1.5, 	—, PNP	10...30 VDC	150 DC, (K)
		<i>uprox</i> [®]	1.5, 	—, PNP	10...30 VDC	150 DC, (K)
		<i>uprox</i> [®]	1.5, 	—, NPN	10...30 VDC	150 DC, (K)
		<i>uprox</i> [®]	1.5, 	—, NPN	10...30 VDC	150 DC, (K)
		-	1.5, 	—, PNP	10...30 VDC	150 DC, (K)
		-	1.5, 	—, NPN	10...30 VDC	150 DC, (K)
	M8 x 1 	⊕ II 2 G SIL2	3, 	NAMUR	nom. 8.2 VDC	-
		-	3, 	—, PNP	10...30 VDC	150 DC, (K)
		-	3, 	—, NPN	10...30 VDC	150 DC, (K)
	M8 x 1 	⊕ II 2 G SIL2	1.5, 	NAMUR	nom. 8.2 VDC	-
		-	1.5, 	—, PNP	10...30 VDC	150 DC, (K)
		-	1.5, 	—, NPN	10...30 VDC	150 DC, (K)
	M8 x 1 	<i>uprox</i> [®] +	6, 	—, PNP	10...30 VDC	150 DC, (K)
		<i>uprox</i> [®] +	6, 	—, NPN	10...30 VDC	150 DC, (K)
		<i>uprox</i> [®]	4, 	—, PNP	10...30 VDC	150 DC, (K)
		<i>uprox</i> [®]	4, 	—, NPN	10...30 VDC	150 DC, (K)
		Sn +	4, 	—, 2-wire	10...55 VDC	100 DC, (K)

型号	订货号	连接方式 (☞ 322)	开关频率 [kHz]	温度范围 [°C]	防护等级	外壳 (☞ 334)	感应面 (☞ 334)	导线 (☞ 334)	LED U _B	LED ┘
BI2U-EG08-AP6X	4602032 ✕	S001	2	-30...+85	IP68	VA	PA	PUR 2 m	-	•
BI2U-EG08-AN6X	4602035 ✕	S004	2	-30...+85	IP68	VA	PA	PUR 2 m	-	•
BI2-EG08-AP6X	4602040 ✕	S001	3	-25...+70	IP67	VA	PA	PUR 2 m	-	•
BI2-EG08-AP6X/S100	4602047 ✕	S001	3	-25...+100	IP67	VA	PA	TPE 2 m	-	•
BI2-EG08-AN6X	4602140 ✕	S004	3	-25...+70	IP67	VA	PA	PUR 2 m	-	•
BI2-EG08-AN6X/S100	4602108	S004	3	-25...+100	IP67	VA	PA	TPE 2 m	-	•
BI2-EG08-AG41X	4562000	S042	1	-25...+70	IP67	VA	PA	PUR 2 m	-	•
BI2-EG08-AZ14X	4100001 ✕	S092	0.02	-25...+70	IP67	VA	PA	PUR 2 m	-	•
BI1,5U-EG08-AP6X	4600500 ✕	S001	2	-30...+85	IP68	VA	PA	PUR 2 m	-	•
BI1,5U-EG08-AP6X 7M	4600501	S001	2	-30...+85	IP68	VA	PA	PUR 7 m	-	•
BI1,5U-EG08-AN6X 7M	4600504	S004	2	-30...+85	IP68	VA	PA	PUR 7 m	-	•
BI1,5U-EG08-AN6X	4600510 ✕	S004	2	-30...+85	IP68	VA	PA	PUR 2 m	-	•
BI1,5-EG08-AP6X	4602240 ✕	S001	3	-25...+70	IP67	VA	PA	PUR 2 m	-	•
BI1,5-EG08-AN6X	4602340 ✕	S004	3	-25...+70	IP67	VA	PA	PUR 2 m	-	•
NI3-EG08K-Y1	1003700 ✕	S025	5	-25...+70	IP67	VA	PA	PVC 2 m	-	-
NI3-EG08K-AP6X	4669600 ✕	S001	3	-25...+70	IP67	VA	PA	PUR 2 m	-	•
NI3-EG08K-AN6X	4669700 ✕	S004	3	-25...+70	IP67	VA	PA	PUR 2 m	-	•
BI1,5-GS880-Y1	1004401	S025	5	-25...+70	IP67	VA	POM	PVC 2 m	-	-
BI1,5-GS880-AP6X	4604401 ✕	S001	3	-25...+70	IP67	VA	POM	PUR 2 m	-	•
BI1,5-GS880-AN6X	4604501	S004	3	-25...+70	IP67	VA	POM	PUR 2 m	-	•
NI6U-EG08-AP6X	4635800 ✕	S001	1	-25...+70	IP68	VA	PA	PUR 2 m	-	•
NI6U-EG08-AN6X	4635803 ✕	S004	1	-25...+70	IP68	VA	PA	PUR 2 m	-	•
NI4U-EG08-AP6X	4600600 ✕	S001	2	-30...+85	IP68	VA	PA	PUR 2 m	-	•
NI4U-EG08-AN6X	4600610 ✕	S004	2	-30...+85	IP68	VA	PA	PUR 2 m	-	•
NI4-EG08-AG41X	4561000	S042	1	-25...+70	IP67	VA	PA	PUR 2 m	-	•

✕ = 优选型号











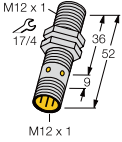

















电感式传感器

尺寸/外形	特性	额定工作距离Sn [mm]	输出	工作电压	额定工作电流Ie [mA]
	M8 x 1	-	3,  , PNP	10...30 VDC	150 DC, 
		-	3,  , NPN	10...30 VDC	150 DC, 
	M12 x 1	<i>uprox</i> [®] +	4,  , PNP	10...30 VDC	200 DC, 
		<i>uprox</i> [®] +	4,  , NPN	10...30 VDC	200 DC, 
	M12 x 1	Sn +	4,  , PNP	10...30 VDC	200 DC, 
	M12 x 1	<i>uprox</i> [®] +	10,  , PNP	10...30 VDC	200 DC, 
	M12 x 1	-	2,  , PNP	10...30 VDC	200 DC, 
	M12 x 1	<i>uprox</i> [®] +	4,  , PNP	10...30 VDC	200 DC, 
		PTFE <i>uprox</i> [®] +	4,  , PNP	10...30 VDC	200 DC, 
		20 bar <i>uprox</i> [®] +	4,  , PNP	10...30 VDC	200 DC, 
		wash down			

型号	订货号	连接方式 (☞ 322)	开关频率 [kHz]	温度范围 [°C]	防护等级	外壳 (☞ 334)	感应面 (☞ 334)	导线 (☞ 334)	LED U _B	LED ┌
NI3-EG08-AP6X	4602740 ✕	S001	3	-25...+70	IP67	VA	PA	PUR 2 m	-	-
NI3-EG08-AN6X	4602840 ✕	S004	3	-25...+70	IP67	VA	PA	PUR 2 m	-	-
BI4U-M12-AP6X-V1131	1634780 ✕	S002	2	-30...+85	IP68	CuZn-Cr	LCP	-	-	•
BI4U-M12-AN6X-V1131	1635430	S005	2	-30...+85	IP68	CuZn-Cr	LCP	-	-	•
BI4-G12-AP6X-V1131	1690703 ✕	S002	2	-25...+70	IP67	CuZn-Cr	PA	-	-	•
NI10U-M12-AP6X-V1131	1634790 ✕	S002	2	-30...+85	IP68	CuZn-Cr	LCP	-	-	•
NI10U-M12-AN6X-V1131	1634795	S005	2	-30...+85	IP68	CuZn-Cr	LCP	-	-	•
BI2-G12K-AP6X-H1141	4670260 ✕	S002	2	-25...+70	IP67	CuZn-Cr	PA	-	-	•
BI4U-M12-AP6X-H1141	1634804 ✕	S002	2	-30...+85	IP68	CuZn-Cr	LCP	-	-	•
BI4U-MT12-AP6X-H1141	1634809 ✕	S002	2	-30...+85	IP68	CuZn-T	LCP	-	-	•
BI4U-EM12WD-AP6X-H1141	1634812 ✕	S002	2	-40...+100	IP68 / IP69K	VA	LCP	-	-	•

✕ = 优选型号











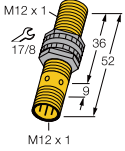





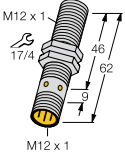









电感式传感器

尺寸/外形	特性	额定工作 距离Sn [mm]	输出	工作电压	额定工作 电流I _e [mA]	
	M12 x 1 	Ex II 3 D 20 bar uprox®+ wash down	4, 	—, PNP	10...30 VDC	200 DC, K
		uprox®+	4, 	 , PNP	10...30 VDC	200 DC, K
		uprox®+	4, 	—, NPN	10...30 VDC	200 DC, K
		PTFE uprox®+	4, 	—, NPN	10...30 VDC	200 DC, K
		20 bar uprox®+ wash down	4, 	—, NPN	10...30 VDC	200 DC, K
		Ex II 3 D 20 bar uprox®+ wash down	4, 	—, NPN	10...30 VDC	200 DC, K
		Sn +	4, 	—, PNP	10...30 VDC	200 DC, K
		Sn +	4, 	 , PNP	10...30 VDC	200 DC, K
		Sn +	4, 	—, NPN	10...30 VDC	200 DC, K
		Sn +	4, 	 , NPN	10...30 VDC	200 DC, K
		uprox®	3, 	—, PNP	10...30 VDC	200 DC, K
		uprox®	3, 	—, PNP	10...30 VDC	200 DC, K
		PTFE uprox®	3, 	—, PNP	10...30 VDC	200 DC, K
		uprox®	3, 	—, NPN	10...30 VDC	200 DC, K
		PTFE uprox®	3, 	—, NPN	10...30 VDC	200 DC, K
		uprox®	3, 	—, NPN	10...30 VDC	200 DC, K
		—	3, 	—, 2-wire	10...65 VDC	100 DC, K
		Ex II 2 G SIL2	2, 	NAMUR	nom. 8.2 VDC	—
		Ex II 1 G Ex II 1 D SIL2	2, 	NAMUR	nom. 8.2 VDC	—
		—	2, 	—, PNP	10...30 VDC	200 DC, K
—	2, 	—, NPN	10...30 VDC	200 DC, K		
—	2, 	 , NPN	10...30 VDC	200 DC, K		
—	2, 	—, 2-wire	10...65 VDC	100 DC, K		

型号	订货号	连接方式 (☞ 322)	开关频率 [kHz]	温度范围 [°C]	防护等级	外壳 (☞ 334)	感应面 (☞ 334)	导线 (☞ 334)	LED U _B	LED ┘
BI4U-EM12WD-AP6X-H1141/3D	1634851 ✕	S002	2	-40...+100	IP68 / IP69K	VA	LCP	-	-	•
BI4U-M12-RP6X-H1141	1634846 ✕	S056	2	-30...+85	IP68	CuZn-Cr	LCP	-	-	•
BI4U-M12-AN6X-H1141	1634824 ✕	S005	2	-30...+85	IP68	CuZn-Cr	LCP	-	-	•
BI4U-MT12-AN6X-H1141	1634829	S005	2	-30...+85	IP68	CuZn-T	LCP	-	-	•
BI4U-EM12WD-AN6X-H1141	1634841	S005	2	-40...+100	IP68 / IP69K	VA	LCP	-	-	•
BI4U-EM12WD-AN6X-H1141/3D	1634852	S005	2	-30...+85	IP68 / IP69K	VA	LCP	-	-	•
BI4-M12-AP6X-H1141	46070 ✕	S002	2	-25...+70	IP67	CuZn-Cr	PA	-	-	•
BI4-M12-VP6X-H1141	1633200 ✕	S008	2	-25...+70	IP67	CuZn-Cr	PA	-	-	•
BI4-M12-AN6X-H1141	46071 ✕	S005	2	-25...+70	IP67	CuZn-Cr	PA	-	-	•
BI4-M12-VN6X-H1141	1643200	S011	2	-25...+70	IP67	CuZn-Cr	PA	-	-	•
BI3U-M12-AP6X-H1141	1634140 ✕	S002	2	-30...+85	IP67	CuZn-Cr	PBT	-	-	•
BI3U-EM12-AP6X-H1141	1634340 ✕	S002	3	-30...+85	IP68	VA	PBT	-	-	•
BI3U-MT12-AP6X-H1141	1634240 ✕	S002	2	-30...+85	IP67	CuZn-T	PBT	-	-	•
BI3U-M12-AN6X-H1141	1634150 ✕	S005	2	-30...+85	IP67	CuZn-Cr	PBT	-	-	•
BI3U-MT12-AN6X-H1141	1634250 ✕	S005	2	-30...+85	IP67	CuZn-T	PBT	-	-	•
BI3U-EM12-AN6X-H1141	1634350 ✕	S005	3	-30...+85	IP68	VA	PBT	-	-	•
BI3-M12-AD4X-H1141	4405041 ✕	S014	1	-25...+70	IP67	CuZn-Cr	PA	-	-	•
BI2-M12-Y1X-H1141	40102 ✕	S026	5	-25...+70	IP67	CuZn-Cr	PA	-	-	•
BI2-EM12-Y1X-H1141	4010201 ✕	S026	5	-25...+70	IP67	VA	PA	-	-	•
BI2-M12-AP6X-H1141	46065 ✕	S002	2	-25...+70	IP67	CuZn-Cr	PA	-	-	•
BI2-M12-AN6X-H1141	46066 ✕	S005	2	-25...+70	IP67	CuZn-Cr	PA	-	-	•
BI2-M12-VN6X-H1141	16430 ✕	S011	2	-25...+70	IP67	CuZn-Cr	PA	-	-	•
BI2-M12-AD4X-H1141	44065 ✕	S014	1	-25...+70	IP67	CuZn-Cr	PA	-	-	•

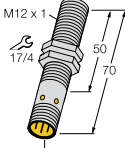
✕ = 优选型号

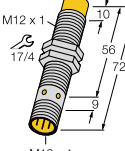
电感式传感器

尺寸/外形	特性	额定工作距离Sn [mm]	输出	工作电压	额定工作电流Ie [mA]	
 <p>M12 x 1</p>	M12 x 1 	<i>uprox</i> [®]	3, 	—, PNP	10...30 VDC	200 DC, (K)
		<i>uprox</i> [®]	3, 	—, NPN	10...30 VDC	200 DC, (K)
		<i>uprox</i> [®]	8, 	—, PNP	10...30 VDC	200 DC, (K)
		<i>uprox</i> [®]	8, 	—, NPN	10...30 VDC	200 DC, (K)
 <p>M12 x 1</p>	M12 x 1 	<i>uprox</i> [®] +	4, 	—, PNP	10...55 VDC	200 DC, (K)
		20 bar	4, 	—, PNP	10...55 VDC	200 DC, (K)
		<i>uprox</i> [®] +	4, 	—, PNP	10...55 VDC	200 DC, (K)
		wash down	4, 	—, PNP	10...55 VDC	200 DC, (K)
		<i>uprox</i> [®] +	4, 	—, NPN	10...55 VDC	200 DC, (K)
		Sn +	4, 	—, PNP	10...30 VDC	200 DC, (K)
		<i>uprox</i> [®]	3, 	—, PNP	10...65 VDC	200 DC, (K)
		<i>uprox</i> [®]	3, 	—, NPN	10...65 VDC	200 DC, (K)
		<i>uprox</i> [®]	3, 	—, NPN	10...65 VDC	200 DC, (K)
		harsh 选择型NF	3, 	—, PNP	10...30 VDC	200 DC, (K)
		harsh 选择型NF	3, 	—, NPN	10...30 VDC	200 DC, (K)
		-	2, 	—, PNP	10...30 VDC	200 DC, (K)
		-	2, 	—, NPN	10...30 VDC	200 DC, (K)
<i>uprox</i> [®] +	2, 	—, 2-wire	10...65 VDC	100 DC, (K)		
<i>uprox</i> [®] +	2, 	—, 2-wire	10...65 VDC	100 DC, (K)		
 <p>M12 x 1</p>	M12 x 1 	选择型FE	3, 	—, PNP	10...30 VDC	200 DC, (K)
 <p>M12 x 1</p>	M12 x 1 	<i>uprox</i> [®]	8, 	—, PNP	10...30 VDC	200 DC, (K)

型号	订货号	连接方式 (☒ 322)	开关频率 [kHz]	温度范围 [°C]	防护等级	外壳 (☒ 334)	感应面 (☒ 334)	导线 (☒ 334)	LED U _B	LED ┌
BI3U-S12-AP6X-H1141	1634600 ✕	S002	3	-30...+85	IP68	PBT	PBT	-	-	•
BI3U-S12-AN6X-H1141	1634620	S005	3	-30...+85	IP68	PBT	PBT	-	-	•
NI8U-S12-AP6X-H1141	1644600 ✕	S002	2	-30...+85	IP68	PBT	PBT	-	-	•
NI8U-S12-AN6X-H1141	1644620	S005	2	-30...+85	IP68	PBT	PBT	-	-	•
BI4U-M12E-VP44X-H1141	1634869 ✕	S008	2	-30...+85	IP68	CuZn-Cr	LCP	-	-	•
BI4U-EM12EWD-VP44X-H1141	1634905 ✕	S008	2	-30...+85	IP68 / IP69K	VA	LCP	-	-	•
BI4U-M12E-VN44X-H1141	1634873 ✕	S011	2	-30...+85	IP68	CuZn-Cr	LCP	-	-	•
BI4-M12E-AP6X-H1141	4608030 ✕	S002	2	-25...+70	IP67	CuZn-Cr	PA	-	-	•
BI3U-M12E-VP4X-H1141	1580252 ✕	S008	3	-30...+85	IP67	CuZn-Cr	PBT	-	-	•
BI3U-M12E-VN4X-H1141	1580354	S011	3	-30...+85	IP67	CuZn-Cr	PBT	-	-	•
BI3U-EM12E-VN4X-H1141	1580363	S011	3	-30...+85	IP68	VA	PBT	-	-	•
BI3NF-EM12HE-AP6X2-H1141	1615001 ✕	S002	3	0...+60	IP67	VA	DURO	-	•	•
BI3NF-EM12HE-AN6X2-H1141	1615003	S005	3	0...+60	IP67	VA	DURO	-	•	•
BI2-M12E-AP6X-H1141	4606505 ✕	S002	2	-25...+70	IP67	CuZn-Cr	PA	-	-	•
BI2-M12E-AN6X-H1141	4606602	S005	2	-25...+70	IP67	CuZn-Cr	PA	-	-	•
BI2U-M12E-AD4X-H1144	4405060	S100	0.01	0...+70	IP68	CuZn-Cr	PA	-	-	•
BI2U-MT12E-AD4X-H1144	4405061	S100	0.02	0...+70	IP68	CuZn-T	LCP	-	-	•
BI3FE-M12FEE-AP6X-H1141	1615108 ✕	S002	0.025	0...+60	IP67	CuZn-OP	VA	-	-	•
NI8U-M12EE-AP6X-H1141	1644147 ✕	S002	2	-30...+85	IP67	CuZn-Cr	PA	-	-	•

✕ = 优选型号

2











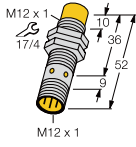















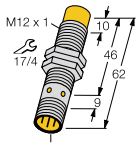

电感式传感器

尺寸/外形	特性	额定工作距离Sn [mm]	输出	工作电压	额定工作电流I _e [mA]	
	M12 x 1 	3,	, PNP	10...30 VDC	200 DC,	
	M12 x 1 	4,	, PNP	10...55 VDC	200 DC,	
	M12 x 1 	4,	, PNP	10...55 VDC	200 DC,	
	M12 x 1 	-	, PNP	10...30 VDC	200 DC,	
		-	, NPN	10...30 VDC	200 DC,	
		-	, PNP	10...30 VDC	200 DC,	
	M12 x 1 	10,	, PNP	10...30 VDC	200 DC,	
		10,	, PNP	10...30 VDC	200 DC,	
		20 bar uprox®+ wash down	10,	, PNP	10...30 VDC	200 DC,
		II 3 D 20 bar uprox®+ wash down	10,	, PNP	10...30 VDC	200 DC,
		uprox®+	10,	, PNP	10...30 VDC	200 DC,
		uprox®+	10,	, NPN	10...30 VDC	200 DC,
		PTFE uprox®+	10,	, NPN	10...30 VDC	200 DC,

型号	订货号	连接方式 (☞ 322)	开关频率 [kHz]	温度范围 [°C]	防护等级	外壳 (☞ 334)	感应面 (☞ 334)	导线 (☞ 334)	LED U _B	LED ┌
BI3U-M12EE-AP6X-H1141	1634149 ✘	S002	3	-30...+85	IP67	CuZn-Cr	PA	-	-	•
BI4U-M12-VP44X-H1141 L80	1634918 ✘	S008	2	-30...+85	IP68	CuZn-Cr	LCP	-	-	•
BI4U-M12-VP44X-H1141 L100	1634917 ✘	S008	2	-30...+85	IP68	CuZn-Cr	LCP	-	-	•
BI2-S12-AP6X-H1141	46520 ✘	S002	2	-25...+70	IP67	PA	PA	-	-	•
BI2-S12-AN6X-H1141	46521	S005	2	-25...+70	IP67	PA	PA	-	-	•
NI4-S12-AP6X-H1141	46522 ✘	S002	2	-25...+70	IP67	PA	PA	-	-	•
NI10U-M12-AP6X-H1141	1634806 ✘	S002	2	-30...+85	IP68	CuZn-Cr	LCP	-	-	•
NI10U-MT12-AP6X-H1141	1634810 ✘	S002	2	-30...+85	IP68	CuZn-T	LCP	-	-	•
NI10U-EM12WD-AP6X-H1141	1634814 ✘	S002	2	-40...+100	IP68 / IP69K	VA	LCP	-	-	•
NI10U-EM12WD-AP6X-H1141/3D	1634857 ✘	S002	2	-40...+100	IP68 / IP69K	VA	LCP	-	-	•
NI10U-M12-RP6X-H1141	1634848 ✘	S056	2	-30...+85	IP68	CuZn-Cr	LCP	-	-	•
NI10U-M12-AN6X-H1141	1634826 ✘	S005	2	-30...+85	IP68	CuZn-Cr	LCP	-	-	•
NI10U-MT12-AN6X-H1141	1634830	S005	2	-30...+85	IP68	CuZn-T	LCP	-	-	•

✘ = 优选型号

电感式传感器











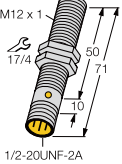



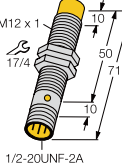



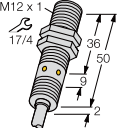



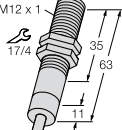



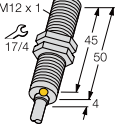





尺寸/外形	特性	额定工作距离Sn [mm]	输出	工作电压	额定工作电流I _e [mA]	
	M12 x 1 	20 bar uprox®+ wash down	10, 	—, NPN	10...30 VDC	200 DC, (K)
		Ex II 3 D 20 bar uprox®+ wash down	10, 	—, NPN	10...30 VDC	200 DC, (K)
		uprox®	8, 	—, PNP	10...30 VDC	200 DC, (K)
		PTFE uprox®	8, 	—, PNP	10...30 VDC	200 DC, (K)
		uprox®	8, 	—, PNP	10...30 VDC	200 DC, (K)
		uprox®	8, 	—, NPN	10...30 VDC	200 DC, (K)
		PTFE uprox®	8, 	—, NPN	10...30 VDC	200 DC, (K)
		uprox®	8, 	—, NPN	10...30 VDC	200 DC, (K)
		Sn +	8, 	—, PNP	10...30 VDC	200 DC, (K)
		Sn +	8, 	—, NPN	10...30 VDC	200 DC, (K)
		-	8, 	—, 2-wire	10...65 VDC	100 DC, (K)
		Ex II 2 G SIL2	5, 	NAMUR	nom. 8.2 VDC	-
		Ex II 1 G Ex II 1 D SIL2	5, 	NAMUR	nom. 8.2 VDC	-
		-	4, 	—, PNP	10...30 VDC	200 DC, (K)
		-	4, 	—, NPN	10...30 VDC	200 DC, (K)
-	4, 	—, NPN	10...30 VDC	200 DC, (K)		
-	4, 	—, 2-wire	10...65 VDC	100 DC, (K)		
	M12 x 1 	uprox®+	10, 	—, PNP	10...30 VDC	200 DC, (K)
		uprox®+	10, 	—, PNP	10...55 VDC	200 DC, (K)
		20 bar uprox®+ wash down	10, 	—, PNP	10...55 VDC	200 DC, (K)
		uprox®+	10, 	—, NPN	10...55 VDC	200 DC, (K)
		uprox®	8, 	—, PNP	10...65 VDC	200 DC, (K)
		uprox®	8, 	—, NPN	10...65 VDC	200 DC, (K)
		uprox®+	5, 	—, 2-wire	10...65 VDC	100 DC, (K)
		uprox®+	5, 	—, 2-wire	10...65 VDC	100 DC, (K)

型号	订货号	连接方式 (☞ 322)	开关频率 [kHz]	温度范围 [°C]	防护等级	外壳 (☞ 334)	感应面 (☞ 334)	导线 (☞ 334)	LED U _B	LED ┘
NI10U-EM12WD-AN6X-H1141	1634837	S005	2	-40...+100	IP68 / IP69K	VA	LCP	-	-	•
NI10U-EM12WD-AN6X-H1141/3D	1634858	S005	2	-30...+85	IP68 / IP69K	V4A	LCP	-	-	•
NI8U-M12-AP6X-H1141	1644140 ✘	S002	2	-30...+85	IP67	CuZn-Cr	PBT	-	-	•
NI8U-MT12-AP6X-H1141	1644240 ✘	S002	2	-30...+85	IP67	CuZn-T	PBT	-	-	•
NI8U-EM12-AP6X-H1141	1644340 ✘	S002	2	-30...+85	IP68	VA	PBT	-	-	•
NI8U-M12-AN6X-H1141	1644150 ✘	S005	2	-30...+85	IP67	CuZn-Cr	PBT	-	-	•
NI8U-MT12-AN6X-H1141	1644250	S005	2	-30...+85	IP67	CuZn-T	PBT	-	-	•
NI8U-EM12-AN6X-H1141	1644350 ✘	S005	2	-30...+85	IP68	VA	PBT	-	-	•
NI8-M12-AP6X-H1141	4611310 ✘	S002	2	-25...+70	IP67	CuZn-Cr	PA	-	-	•
NI8-M12-AN6X-H1141	4611315	S005	2	-25...+70	IP67	CuZn-Cr	PA	-	-	•
NI8-M12-AD4X-H1141	4411241 ✘	S014	1	-25...+70	IP67	CuZn-Cr	PA	-	-	•
NI5-M12-Y1X-H1141	40103 ✘	S026	2	-25...+70	IP67	CuZn-Cr	PA	-	-	•
NI5-EM12-Y1X-H1141	4010301 ✘	S026	2	-25...+70	IP67	VA	PA	-	-	•
NI4-M12-AP6X-H1141	46067 ✘	S002	2	-25...+70	IP67	CuZn-Cr	PA	-	-	•
NI4-M12-AN6X-H1141	46068 ✘	S005	2	-25...+70	IP67	CuZn-Cr	PA	-	-	•
NI4-M12-VN6X-H1141	16431 ✘	S011	2	-25...+70	IP67	CuZn-Cr	PA	-	-	•
NI4-M12-AD4X-H1141	44067 ✘	S014	1	-25...+70	IP67	CuZn-Cr	PA	-	-	•
NI10U-M12E-AP6X-H1141	1634901	S002	2	-30...+85	IP68	CuZn-Cr	LCP	-	-	•
NI10U-M12E-VP44X-H1141	1634871 ✘	S008	2	-30...+85	IP68	CuZn-Cr	LCP	-	-	•
NI10U-EM12EWD-VP44X-H1141	1634896	S008	2	-30...+85	IP68 / IP69K	VA	LCP	-	-	•
NI10U-M12E-VN44X-H1141	1634875 ✘	S011	2	-30...+85	IP68	CuZn-Cr	LCP	-	-	•
NI8U-M12E-VP4X-H1141	1580454 ✘	S008	2	-30...+85	IP67	CuZn-Cr	PBT	-	-	•
NI8U-M12E-VN4X-H1141	1580552 ✘	S011	2	-30...+85	IP67	CuZn-Cr	PBT	-	-	•
NI5U-M12E-AD4X-H1144	4405063 ✘	S99	0.01	0...+70	IP68	CuZn-Cr	LCP	-	-	•
NI5U-MT12E-AD4X-H1144	4405065 ✘	S99	0.01	0...+70	IP68	CuZn-T	LCP-T	-	-	•

✘ = 优选型号

2











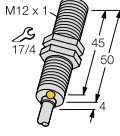















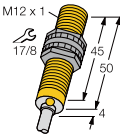























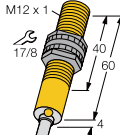













电感式传感器

尺寸/外形	特性	额定工作距离Sn [mm]	输出	工作电压	额定工作电流I _e [mA]
 <p>M12 x 1 17/4 50 71 10 1/2-20UNF-2A</p>	M12 x 1 	2, 		20...250 VAC 10...300 VDC	100 AC 100 DC, (K)
 <p>M12 x 1 17/4 50 71 10 1/2-20UNF-2A</p>	M12 x 1 	8, 		20...250 VAC 10...300 VDC	100 AC 100 DC, (K)
 <p>M12 x 1 17/4 50 36 9 2</p>	M12 x 1 	20 bar <i>uprox</i> [®] + wash down	4,  , PNP	10...30 VDC	200 DC, (K)
		20 bar <i>uprox</i> [®] + wash down	4,  , NPN	10...30 VDC	200 DC, (K)
 <p>M12 x 1 17/4 63 35 11</p>	M12 x 1 	T +120 °C wash down	2,  , PNP	10...30 VDC	200 DC, (K)
		20 bar wash down T -60 °C	2,  , PNP	10...30 VDC	200 DC, (K)
 <p>M12 x 1 17/4 50 45 4</p>	M12 x 1 	<i>uprox</i> [®] +	4,  , PNP	10...30 VDC	200 DC, (K)
		<i>uprox</i> [®] +	4,  , PNP	10...30 VDC	200 DC, (K)
		<i>uprox</i> [®] +	4,  , NPN	10...30 VDC	200 DC, (K)
		Sn +	4,  , PNP	10...30 VDC	200 DC, (K)
		Sn +	4,  , PNP	10...30 VDC	200 DC, (K)
		Sn +	4,  , NPN	10...30 VDC	200 DC, (K)
		Sn +	4,  , NPN	10...30 VDC	200 DC, (K)
		<i>uprox</i> [®]	3,  , PNP	10...30 VDC	200 DC, (K)
		<i>uprox</i> [®]	3,  , PNP	10...30 VDC	200 DC, (K)
		<i>uprox</i> [®]	3,  , NPN	10...30 VDC	200 DC, (K)
		<i>uprox</i> [®]	3,  , NPN	10...30 VDC	200 DC, (K)
		-	3,  , 2-wire	10...65 VDC	100 DC, (K)
		-	2,  , PNP	10...30 VDC	200 DC, (K)
T +100 °C	2,  , PNP	10...30 VDC	200 DC, (K)		

型号	订货号	连接方式 (☞ 322)	开关频率 [kHz]	温度范围 [°C]	防护等级	外壳 (☞ 334)	感应面 (☞ 334)	导线 (☞ 334)	LED U _B	LED ┌
BI2U-G12-ADZ32X-B3131	4281005 ✕	S019	0.02	-30...+85	IP67	CuZn-Cr	PA	-	-	•
NI8U-G12-ADZ32X-B3131	4281105 ✕	S019	0.02	-30...+85	IP67	CuZn-Cr	PA	-	-	•
BI4U-EM12WD-AP6X	1634811 ✕	S001	2	-40...+100	IP68 / IP69K	VA	LCP	PVC 2 m	-	•
BI4U-EM12WD-AN6X	1634842	S004	2	-40...+100	IP68 / IP69K	VA	LCP	PVC 2 m	-	•
BI2-EM12D-AP6/S120	4614512 ✕	S001	0.1	-25...+120	IP68 / IP69K	VA	PTFE	PTFE 2 m	-	-
BI2-EM12WD-AP6/S929	4614515	S001	1	-60...+60	IP68 / IP69K	VA	PTFE	FEP 2 m	-	-
BI4U-M12-AP6X	1634803 ✕	S001	2	-30...+85	IP68	CuZn-Cr	LCP	PVC 2 m	-	•
BI4U-M12-RP6X	1634866 ✕	S054	2	-30...+85	IP68	CuZn-Cr	LCP	PVC 2 m	-	•
BI4U-M12-AN6X	1634823	S004	2	-30...+85	IP68	CuZn-Cr	LCP	PVC 2 m	-	•
BI4-M12-AP6X	4607006 ✕	S001	2	-25...+70	IP67	CuZn-Cr	PA	PVC 2 m	-	•
BI4-M12-VP6X	1633300	S007	2	-25...+70	IP67	CuZn-Cr	PA	PVC 2 m	-	•
BI4-M12-AN6X	4607130	S004	2	-25...+70	IP67	CuZn-Cr	PA	PVC 2 m	-	•
BI4-M12-VN6X	1643300	S010	2	-25...+70	IP67	CuZn-Cr	PA	PVC 2 m	-	•
BI3U-M12-AP6X	1634100 ✕	S001	2	-30...+85	IP67	CuZn-Cr	PA	PVC 2 m	-	•
BI3U-EM12-AP6X	1634300 ✕	S001	3	-30...+85	IP68	VA	PBT	PVC 2 m	-	•
BI3U-M12-AN6X	1634120 ✕	S004	2	-30...+85	IP67	CuZn-Cr	PA	PVC 2 m	-	•
BI3U-EM12-AN6X	1634320	S004	3	-30...+85	IP68	VA	PBT	PVC 2 m	-	•
BI3-M12-AD4X	4405035	S013	1	-25...+70	IP67	CuZn-Cr	PA	PVC 2 m	-	•
BI2-M12-AP6X	46050 ✕	S001	2	-25...+70	IP67	CuZn-Cr	PA	PVC 2 m	-	•
BI2-M12-AP6X/S100	4605003 ✕	S001	2	-25...+100	IP67	CuZn-Cr	PA-X	PVC 2 m	-	•

✕ = 优选型号











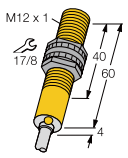













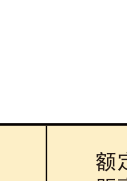



























电感式传感器

尺寸/外形	特性	额定工作距离Sn [mm]	输出	工作电压	额定工作电流Ie [mA]	
	M12 x 1 	-	2, 	 , PNP	10...30 VDC	200 DC, (K)
		-	2, 	 , NPN	10...30 VDC	200 DC, (K)
		-	2, 	 , NPN	10...30 VDC	200 DC, (K)
		-	2, 	 , NPN	10...30 VDC	200 DC, (K)
		-	2, 	 , 2-wire	10...65 VDC	100 DC, (K)
		Sn +	4, 	 , NPN	10...30 VDC	200 DC, (K)
		Sn +	4, 	 , NPN	10...30 VDC	200 DC, (K)
	M12 x 1 	uprox®	3, 	 , PNP	10...30 VDC	200 DC, (K)
		uprox®	3, 	 , NPN	10...30 VDC	200 DC, (K)
		uprox®	8, 	 , PNP	10...30 VDC	200 DC, (K)
		uprox®	8, 	 , NPN	10...30 VDC	200 DC, (K)
	M12 x 1 	Sn +	4, 	 , PNP	10...30 VDC	200 DC, (K)
		Sn +	4, 	 , NPN	10...30 VDC	200 DC, (K)
		-	3, 	 , 2-wire	10...65 VDC	100 DC, (K)
		Ex II 2 G SIL2	2, 	NAMUR	nom. 8.2 VDC	-
		Ex I M1	2, 	NAMUR	nom. 8.2 VDC	-
		Ex II 1 G Ex II 1 D SIL2 T +100 °C	2, 	NAMUR	nom. 8.2 VDC	-
		-	2, 	 , PNP	10...30 VDC	200 DC, (K)
		-	2, 	 , NPN	10...30 VDC	200 DC, (K)
	M12 x 1 	-	2, 	 , PNP	10...30 VDC	200 DC, (K)
		T -40 °C	2, 	 , PNP	10...30 VDC	200 DC, (K)
		T +100 °C	2, 	 , PNP	10...30 VDC	200 DC, (K)
		-	2, 	 , NPN	10...30 VDC	200 DC, (K)
		-	2, 	 , 2-wire	10...65 VDC	100 DC, (K)
		-	2, 		20...250 VAC 10...300 VDC	100 AC 100 DC
		T -40 °C	2, 		20...250 VAC 10...300 VDC	100 AC 100 DC
		T +100 °C	2, 		20...250 VAC 10...300 VDC	100 AC 100 DC
		-	4, 	 , PNP	10...30 VDC	200 DC, (K)
		T -40 °C	4, 	 , PNP	10...30 VDC	200 DC, (K)
		T +100 °C	4, 	 , PNP	10...30 VDC	200 DC, (K)

型号	订货号	连接方式 (☞ 322)	开关频率 [kHz]	温度范围 [°C]	防护等级	外壳 (☞ 334)	感应面 (☞ 334)	导线 (☞ 334)	LED U _B	LED ┘
BI2-EM12-VP6X 7M	1630230 ✕	S007	2	-25...+70	IP67	VA	PA	PVC 7 m	-	●
BI2-M12-AN6X	46051 ✕	S004	2	-25...+70	IP67	CuZn-Cr	PA	PVC 2 m	-	●
BI2-M12-VN6X	16402 ✕	S010	2	-25...+70	IP67	CuZn-Cr	PA	PVC 2 m	-	●
BI2-EM12-VN6X 7M	1630231	S010	2	-25...+70	IP67	VA	PA	PVC 7 m	-	●
BI2-M12-AD4X	44050 ✕	S013	1	-25...+70	IP67	CuZn-Cr	PA	PVC 2 m	-	●
BI4-M12-AN6X	4607130 ✕	S004	2	-25...+70	IP67	CuZn-Cr	PA	PVC 2 m	-	●
BI4-M12-VN6X	1643300 ✕	S010	2	-25...+70	IP67	CuZn-Cr	PA	PVC 2 m	-	●
BI3U-S12-AP6X	1634500 ✕	S001	3	-30...+85	IP68	PBT	PBT	PVC 2 m	-	●
BI3U-S12-AN6X	1634520	S004	3	-30...+85	IP68	PBT	PBT	PVC 2 m	-	●
NI8U-S12-AP6X	1644500 ✕	S001	2	-30...+85	IP68	PBT	PBT	PVC 2 m	-	●
NI8U-S12-AN6X	1644520	S004	2	-30...+85	IP68	PBT	PBT	PVC 2 m	-	●
BI4-G12K-AP6X	4670250 ✕	S001	2	-25...+70	IP67	CuZn-Cr	PA	PVC 2 m	-	●
BI4-G12K-AN6X	4670251	S004	2	-25...+70	IP67	CuZn-Cr	PA	PVC 2 m	-	●
BI3-G12K-AD4X	4405030	S013	1	-25...+70	IP67	CuZn-Cr	PA	PVC 2 m	-	●
BI2-G12-Y1X	40100 ✕	S025	5	-25...+70	IP67	CuZn-Cr	PA	PVC 2 m	-	●
BI2-G12-Y2X 7M	4010501	S025	5	-25...+70	IP67	CuZn-Cr	PA	PVC 7 m	-	●
BI2-EG12-Y1X/S100 7M	4012003 ✕	S025	5	-25...+100	IP67	VA	PA	PVC 7 m	-	●
BI2-G12K-AP6X	46702 ✕	S001	2	-25...+70	IP67	CuZn-Cr	PA	PVC 2 m	-	●
BI2-G12K-AN6X	46712 ✕	S004	2	-25...+70	IP67	CuZn-Cr	PA	PVC 2 m	-	●
BI2-S12-AP6X	46530 ✕	S001	2	-25...+70	IP67	PA	PA	PVC 2 m	-	●
BI2-S12-AP6X/S97	16645	S001	2	-40...+70	IP67	PA	PA	Silic.	-	●
BI2-S12-AP6X/S100	4653023 ✕	S001	2	-25...+100	IP67	PA	PA	PVC 2 m	-	●
BI2-S12-AN6X	46531 ✕	S004	2	-25...+70	IP67	PA	PA	PVC 2 m	-	●
BI2-S12-AD4X	44530 ✕	S013	1	-25...+70	IP67	PA	PA	PVC 2 m	-	●
BI2-S12-AZ31X	13020 ✕	S092	0.02	-25...+70	IP67	PA	PA	PVC 2 m	-	●
BI2-S12-AZ31X/S97	1302002	S092	0.02	-40...+70	IP67	PA	PA	Silic. 2 m	-	●
BI2-S12-AZ31X/S100	1302001	S092	0.02	-25...+100	IP67	PA	PA	PVC 2 m	-	●
NI4-S12-AP6X	46532 ✕	S001	2	-25...+70	IP67	PA	PA	PVC 2 m	-	●
NI4-S12-AP6X/S97	4653221	S001	2	-40...+70	IP67	PA	PA	Silic. 2 m	-	●
NI4-S12-AP6X/S100	4653201 ✕	S001	2	-25...+100	IP67	PA	PA	PVC 2 m	-	●

✕ = 优选型号

















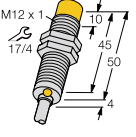

















电感式传感器

尺寸/外形	特性	额定工作距离Sn [mm]	输出	工作电压	额定工作电流I _e [mA]	
	M12 x 1	-	4, 	- , NPN	10...30 VDC	200 DC, 
		-	4, 	- , 2-wire	10...65 VDC	100 DC, 
	-	4, 		20...250 VAC 10...300 VDC	100 AC 100 DC	
	T -40 °C	4, 		20...250 VAC 10...300 VDC	100 AC 100 DC	
	T -40 °C	4, 		20...250 VAC 10...300 VDC	100 AC 100 DC	
	T +100 °C	4, 		20...250 VAC 10...300 VDC	100 AC 100 DC	
	M12 x 1	<i>uprox</i> [®] +	4, 	 , PNP	10...55 VDC	200 DC, 
		<i>uprox</i> [®] +	4, 	 , NPN	10...55 VDC	200 DC, 
	-	<i>uprox</i> [®]	3, 	 , PNP	10...65 VDC	200 DC, 
	-	<i>uprox</i> [®]	3, 	 , NPN	10...65 VDC	200 DC, 
	-	<i>uprox</i> [®]	3, 	 , NPN	10...65 VDC	200 DC, 
	-	-	2, 		20...250 VAC 10...300 VDC	100 AC 100 DC
	-	<i>uprox</i> [®] +	2, 		10...65 VDC	100 DC 
	M12 x 1	-	8, 	- , 2-wire	10...65 VDC	100 DC, 
			5, 	NAMUR	nom. 8.2 VDC	-
	-		5, 	NAMUR	nom. 8.2 VDC	-
	-		5, 	NAMUR	nom. 8.2 VDC	-
	T +100 °C	-	5, 	 , PNP	10...30 VDC	200 DC, 
	-	-	5, 	 , NPN	10...30 VDC	200 DC, 

型号	订货号	连接方式 (☞ 322)	开关频率 [kHz]	温度范围 [°C]	防护等级	外壳 (☞ 334)	感应面 (☞ 334)	导线 (☞ 334)	LED U _B	LED ┘
NI4-S12-AN6X	46533 ✕	S004	2	-25...+70	IP67	PA	PA	PVC 2 m	-	•
NI4-S12-AD4X	44532 ✕	S013	1	-25...+70	IP67	PA	PA	PVC 2 m	-	•
NI4-S12-AZ31X	13022 ✕	S092	0.02	-25...+70	IP67	PA	PA	PVC 2 m	-	•
NI4-S12-AZ31X/S97	1302202	S092	0.02	-40...+70	IP67	PA	PA	Silic. 2 m	-	•
NI4-S12-AZ31X/S97 3M	1302203	S092	0.02	-40...+70	IP67	PA	PA	Silic. 3m	-	•
NI4-S12-AZ31X/S100	1302201	S092	0.02	-25...+100	IP67	PA	PA	PVC 2 m	-	•
BI4U-M12E-VP44X	1634868 ✕	S007	2	-30...+85	IP68	CuZn-Cr	LCP	PVC 2 m	-	•
BI4U-M12E-VN44X	1634872	S010	2	-30...+85	IP68	CuZn-Cr	LCP	PVC 2 m	-	•
BI3U-M12E-VP4X	1580203 ✕	S007	3	-30...+85	IP67	CuZn-Cr	PBT	PVC 2 m	-	•
BI3U-M12E-VN4X	1580302	S010	3	-30...+85	IP67	CuZn-Cr	PBT	PVC 2 m	-	•
BI3U-EM12E-VN4X	1580362	S010	3	-30...+85	IP68	VA	PBT	PVC 2 m	-	•
BI2-M12-AZ31X	13030 ✕	S092	0.02	-25...+70	IP67	CuZn-Cr	PA	PVC 2 m	-	•
BI2U-M12E-AD4X	4405062	S013	0.02	0...+70	IP68	CuZn-Cr	PA	PVC 2 m	-	•
NI8-G12K-AD4X	4411230	S013	0.5	-25...+70	IP67	CuZn-Cr	PA	PVC 2 m	-	•
NI5-G12-Y1X	40101 ✕	S025	2	-25...+70	IP67	CuZn-Cr	PA	PVC 2 m	-	•
NI5-EG12-Y1X/S100 7M	4012008 ✕	S025	2	-25...+100	IP67	VA	PA	PVC 7 m	-	•
NI5-G12K-AP6X	46703 ✕	S001	1.5	-25...+70	IP67	CuZn-Cr	PA	PVC 2 m	-	•
NI5-G12K-AN6X	46713 ✕	S004	1.5	-25...+70	IP67	CuZn-Cr	PA	PVC 2 m	-	•

✕ = 优选型号

电感式传感器











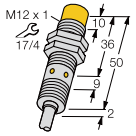

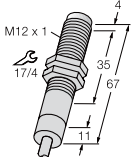

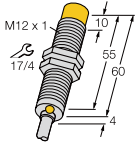

尺寸/外形	特性	额定工作距离Sn [mm]	输出	工作电压	额定工作电流I _e [mA]	
	M12 x 1					
	□	Ⓢ II 2 G SIL2	2, 	NAMUR	nom. 8.2 VDC	-
		Ⓢ II 2 G SIL2 T -40 °C	2, 	NAMUR	nom. 8.2 VDC	-
		Ⓢ II 2 G SIL2 T +100 °C	2, 	NAMUR	nom. 8.2 VDC	-
		Ⓢ II 2 G SIL2	5, 	NAMUR	nom. 8.2 VDC	-
		Ⓢ II 2 G SIL2 T -40 °C	5, 	NAMUR	nom. 8.2 VDC	-
		Ⓢ II 2 G SIL2 T +100 °C	5, 	NAMUR	nom. 8.2 VDC	-
	M12 x 1					
	□	<i>uprox</i> [®] +	10, 	 , PNP	10...30 VDC	200 DC, (K)
		<i>uprox</i> [®] +	10, 	 , NPN	10...30 VDC	200 DC, (K)
		<i>uprox</i> [®]	8, 	 , PNP	10...30 VDC	200 DC, (K)
		<i>uprox</i> [®]	8, 	 , PNP	10...30 VDC	200 DC, (K)
		<i>uprox</i> [®]	8, 	 , NPN	10...30 VDC	200 DC, (K)
		<i>uprox</i> [®]	8, 	 , NPN	10...30 VDC	200 DC, (K)
		-	8, 	 , 2-wire	10...65 VDC	100 DC, (K)
		-	4, 	 , PNP	10...30 VDC	200 DC, (K)
		-	4, 	 , PNP	10...30 VDC	200 DC, (K)
		T +100 °C	4, 	 , PNP	10...30 VDC	200 DC, (K)
		-	4, 	 , NPN	10...30 VDC	200 DC, (K)
		-	4, 	 , NPN	10...30 VDC	200 DC, (K)
		-	4, 	 , NPN	10...30 VDC	200 DC, (K)
	-	4, 	 , 2-wire	10...65 VDC	100 DC, (K)	

型号	订货号	连接方式 (☞ 322)	开关频率 [kHz]	温度范围 [°C]	防护等级	外壳 (☞ 334)	感应面 (☞ 334)	导线 (☞ 334)	LED U _B	LED ┘
BI2-P12-Y1X	40300 ✕	S025	5	-25...+70	IP67	PA	PA	PVC 2 m	-	•
BI2-P12-Y1X/S97	4030021	S025	5	-40...+70	IP67	PA	PA	Silic. 2 m	-	•
BI2-P12-Y1/S100	10302 ✕	S025	5	-25...+100	IP67	PA	PA	PVC 2 m	-	-
NI5-P12-Y1X	40301 ✕	S025	2	-25...+70	IP67	PA	PA	PVC 2 m	-	•
NI5-P12-Y1X/S97	1009402	S025	2	-40...+70	IP67	PA	PA	Silic. 2 m	-	•
NI5-P12-Y1X /S100	10242	S025	2	-25...+100	IP67	PA	PA	PVC 2 m	-	-
NI10U-M12-AP6X	1634805 ✕	S001	2	-30...+85	IP68	CuZn-Cr	LCP	PVC 2 m	-	•
NI10U-M12-AN6X	1634825 ✕	S004	2	-30...+85	IP68	CuZn-Cr	LCP	PVC 2 m	-	•
NI8U-M12-AP6X	1644100 ✕	S001	2	-30...+85	IP67	CuZn-Cr	PBT	PVC 2 m	-	•
NI8U-EM12-AP6X	1644300 ✕	S001	2	-30...+85	IP68	VA	PBT	PVC 2 m	-	•
NI8U-M12-AN6X	1644120 ✕	S004	2	-30...+85	IP67	CuZn-Cr	PBT	PVC 2 m	-	•
NI8U-EM12-AN6X	1644320	S004	2	-30...+85	IP68	VA	PBT	PVC 2 m	-	•
NI8-M12-AD4X	4411235 ✕	S013	1	-25...+70	IP67	CuZn-Cr	PA	PVC 2 m	-	•
NI4-M12-AP6X	46052 ✕	S001	2	-25...+70	IP67	CuZn-Cr	PA	PVC 2 m	-	•
NI4-EM12-VP6X 7M	1630233 ✕	S007	2	-25...+70	IP67	VA	PA	PVC 7 m	-	•
NI4-M12-AP6X/S100	4605201 ✕	S001	2	-25...+100	IP67	CuZn-Cr	PA-X	PVC 2 m	-	•
NI4-M12-AN6X	46053 ✕	S004	2	-25...+70	IP67	CuZn-Cr	PA	PVC 2 m	-	•
NI4-M12-VN6X	16404 ✕	S010	2	-25...+70	IP67	CuZn-Cr	PA	PVC 2 m	-	•
NI4-EM12-VN6X 7M	1630232	S010	2	-25...+70	IP67	VA	PA	PVC 7 m	-	•
NI4-M12-AD4X	44052 ✕	S013	1	-25...+70	IP67	CuZn-Cr	PA	PVC 2 m	-	•

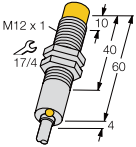
✕ = 优选型号

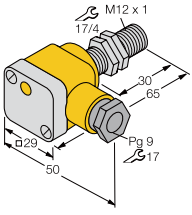
2

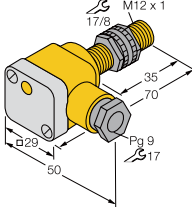









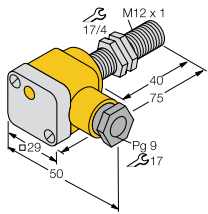













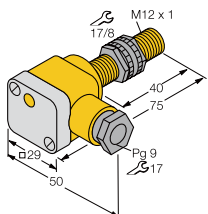























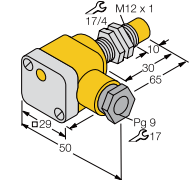





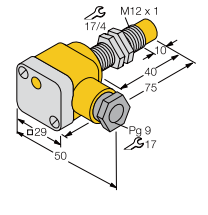







电感式传感器

尺寸/外形	特性	额定工作距离Sn [mm]	输出	工作电压	额定工作电流I _e [mA]
	M12 x 1 □	20 bar <i>uprox</i> [®] + wash down	10, 	—, PNP	10...30 VDC 200 DC, (K)
		20 bar <i>uprox</i> [®] + wash down	10, 	—, NPN	10...30 VDC 200 DC, (K)
	M12 x 1 □	T +120 °C wash down	4, 	—, PNP	10...30 VDC 200 DC, (K)
		20 bar wash down T -60 °C	4, 	—, PNP	10...30 VDC 200 DC, (K)
	M12 x 1 □	<i>uprox</i> [®] +	10, 	—, PNP	10...55 VDC 200 DC, (K)
		<i>uprox</i> [®] +	10, 	—, NPN	10...55 VDC 200 DC, (K)
		<i>uprox</i> [®]	8, 	—, PNP	10...65 VDC 200 DC, (K)
		<i>uprox</i> [®]	8, 	—, NPN	10...65 VDC 200 DC, (K)
		<i>uprox</i> [®] +	5, 	—, 2-wire	10...65 VDC 100 DC (K)
	M12 x 1 □	—	4, 	—	20...250 VAC 10...300 VDC 100 AC 100 DC
	M12 x 1 □	⊕ II 2 G SIL2	2, 	NAMUR	nom. 8.2 VDC —
		⊕ II 1 G	2, 	NAMUR	nom. 8.2 VDC —
		⊕ II 1 D SIL2			
	M12 x 1 □	⊕ II 2 G SIL2	2, 	NAMUR	nom. 8.2 VDC —
		⊕ II 2 G SIL2	5, 	NAMUR	nom. 8.2 VDC —

型号	订货号	连接方式 (☞ 322)	开关频率 [kHz]	温度范围 [°C]	防护等级	外壳 (☞ 334)	感应面 (☞ 334)	导线 (☞ 334)	LED U _B	LED ┘
NI10U-EM12WD-AP6X	1634813 ✕	S001	2	-40...+100	IP68 / IP69K	VA	LCP	PP 2 m	-	•
NI10U-EM12WD-AN6X	1634838	S004	2	-40...+100	IP68 / IP69K	VA	LCP	PP 2 m	-	•
NI4-EM12D-AP6/S120	1633110 ✕	S001	0.1	-25...+120	IP68 / IP69K	VA	PTFE	PTFE 2 m	-	-
NI4-EM12WD-AP6/S929	1633111	S001	1	-60...+60	IP68 / IP69K	VA	PTFE	FEP 2 m	-	-
NI10U-M12E-VP44X	1634870 ✕	S007	2	-30...+85	IP68	CuZn-Cr	LCP	PVC 2 m	-	•
NI10U-M12E-VN44X	1634874	S010	2	-30...+85	IP68	CuZn-Cr	LCP	PVC 2 m	-	•
NI8U-M12E-VP4X	1580406 ✕	S007	2	-30...+85	IP67	CuZn-Cr	PBT	PVC 2 m	-	•
NI8U-M12E-VN4X	1580501 ✕	S010	2	-30...+85	IP67	CuZn-Cr	PBT	PVC 2 m	-	•
BI5U-M12E-AD4X	4405064 ✕	S013	0.01	0...+70	IP68	CuZn-Cr	LCP	PVC 2 m	-	•
NI4-M12-AZ31X	13032 ✕	S092	0.02	-25...+70	IP67	CuZn-Cr	PA	PVC 2 m	-	•
BI2-G12SK-Y1X	40110 ✕	S027	5	-25...+70	IP67	CuZn-Cr	PA	-	-	•
BI2-EG12SK-Y1X	4012050 ✕	S027	5	-25...+70	IP67	VA	PA	-	-	•
BI2-P12SK-Y1X	40310 ✕	S027	5	-25...+70	IP67	PA	PA	-	-	•
NI5-P12SK-Y1X	40311 ✕	S027	2	-25...+70	IP67	PA	PA	-	-	•

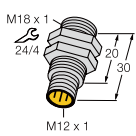
✕ = 优选型号











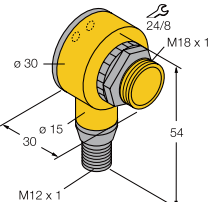

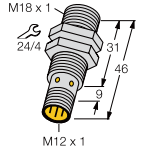

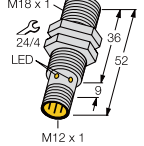















电感式传感器

尺寸/外形	特性	额定工作距离Sn [mm]	输出	工作电压	额定工作电流Ie [mA]		
	M12 x 1 	<i>uprox</i> [®]	3, 	—, PNP	10...30 VDC	200 DC, 	
		<i>uprox</i> [®]	3, 	—, PNP	10...65 VDC	200 DC, 	
		<i>uprox</i> [®]	3, 	—, NPN	10...30 VDC	200 DC, 	
		<i>uprox</i> [®]	3, 	—, NPN	10...65 VDC	200 DC, 	
		—	2, 	—, PNP	10...30 VDC	200 DC, 	
		—	2, 	—, NPN	10...30 VDC	200 DC, 	
	M12 x 1 	<i>uprox</i> [®]	3, 	—, PNP	10...30 VDC	200 DC, 	
		<i>uprox</i> [®]	3, 	—, NPN	10...30 VDC	200 DC, 	
		—	2, 	—, PNP	10...30 VDC	200 DC, 	
		—	2, 	—, NPN	10...30 VDC	200 DC, 	
		<i>uprox</i> [®]	8, 	—, PNP	10...30 VDC	200 DC, 	
		<i>uprox</i> [®]	8, 	—, NPN	10...30 VDC	200 DC, 	
		—	5, 	—, PNP	10...30 VDC	200 DC, 	
		—	5, 	—, NPN	10...30 VDC	200 DC, 	
	M12 x 1 	T+100°C wash down	5, 	NAMUR	nom. 8.2 VDC	—	
	M12 x 1 	T+100°C <i>uprox</i> [®] + wash down	10, 	—, PNP	10...30 VDC	200 DC, 	
	M12 x 1 	 II 2 G SIL2	5, 	NAMUR	nom. 8.2 VDC	—	
		 II 1 G	5, 	NAMUR	nom. 8.2 VDC	—	
		 II 1 D SIL2					
	M12 x 1 	<i>uprox</i> [®]	8, 	—, PNP	10...30 VDC	200 DC, 	
		<i>uprox</i> [®]	8, 	—, PNP	10...65 VDC	200 DC, 	
		<i>uprox</i> [®]	8, 	—, NPN	10...30 VDC	200 DC, 	
		<i>uprox</i> [®]	8, 	—, NPN	10...65 VDC	200 DC, 	
		—	5, 	—, PNP	10...30 VDC	200 DC, 	
		—	5, 	—, NPN	10...30 VDC	200 DC, 	
	M18 x 1 	—	5, 	—, PNP	10...30 VDC	200 DC, 	

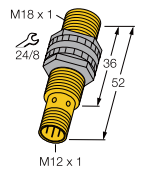
型号	订货号	连接方式 (☞ 322)	开关频率 [kHz]	温度范围 [°C]	防护等级	外壳 (☞ 334)	感应面 (☞ 334)	导线 (☞ 334)	LED U _B	LED ┌
BI3U-EG12SK-AP6X	1634400 ✕	S003	3	-30...+85	IP68	VA	PBT	-	-	•
BI3U-EG12SK-VP4X	1580601 ✕	S009	3	-30...+85	IP68	VA	PBT	-	-	•
BI3U-EG12SK-AN6X	1634420	S006	3	-30...+85	IP68	VA	PBT	-	-	•
BI3U-EG12SK-VN4X	1580701	S012	3	-30...+85	IP68	VA	PBT	-	-	•
BI2-G12SK-AP6X	46360 ✕	S003	2	-25...+70	IP67	CuZn-Cr	PA	-	-	•
BI2-G12SK-AN6X	46361	S006	2	-25...+70	IP67	CuZn-Cr	PA	-	-	•
BI3U-P12SK-AP6X	1634700 ✕	S003	3	-30...+85	IP68	PA	PA	-	-	•
BI3U-P12SK-AN6X	1634720	S006	3	-30...+85	IP68	PA	PA	-	-	•
BI2-P12SK-AP6X	46535 ✕	S003	2	-25...+70	IP67	PA	PA	-	-	•
BI2-P12SK-AN6X	46536	S006	2	-25...+70	IP67	PA	PA	-	-	•
NI8U-P12SK-AP6X	1644700 ✕	S003	2	-30...+85	IP68	PA	PA	-	-	•
NI8U-P12SK-AN6X	1644720	S006	2	-30...+85	IP68	PA	PA	-	-	•
NI5-P12SK-AP6X	46537 ✕	S003	1.5	-25...+70	IP67	PA	PA	-	-	•
NI5-P12SK-AN6X	46538	S006	1.5	-25...+70	IP67	PA	PA	-	-	•
NI5-EM12WDTC-Y1X	4012141 ✕	S027	2	-40...+100	IP68/IP69K	V4A, LCP	LCP	-	-	•
NI10U-EM12WDTC-AP6X	1634761 ✕	S003	2	-40...+100	IP68/IP69K	V4A, LCP	LCP	-	-	•
NI5-G12SK-Y1X	40111 ✕	S027	2	-25...+70	IP67	CuZn-Cr	PA	-	-	•
NI5-EG12SK-Y1X	4012140 ✕	S027	2	-25...+70	IP67	VA	PA	-	-	•
NI8U-EG12SK-AP6X	1644400 ✕	S003	2	-30...+85	IP68	VA	PBT	-	-	•
NI8U-EG12SK-VP4X	1580901 ✕	S009	2	-30...+85	IP68	VA	PBT	-	-	•
NI8U-EG12SK-AN6X	1644420	S006	2	-30...+85	IP68	VA	PBT	-	-	•
NI8U-EG12SK-VN4X	1580902	S012	2	-30...+85	IP68	VA	PBT	-	-	•
NI5-G12SK-AP6X	46362 ✕	S003	1.5	-25...+70	IP67	CuZn-Cr	PA	-	-	•
NI5-G12SK-AN6X	46363 ✕	S006	1.5	-25...+70	IP67	CuZn-Cr	PA	-	-	•
BI5-G18KK-AP6-H1141	4670410 ✕	S002	0.5	-25...+70	IP67	CuZn-Cr	PA	-	-	-

✕ = 优选型号

电感式传感器

尺寸/外形	特性	额定工作距离 Sn [mm]	输出	工作电压	额定工作电流 I _e [mA]
	M18 x 1 	5, 	—, PNP	10...30 VDC	200 DC, (K)
	M18 x 1 	8, 	—, PNP	10...30 VDC	200 DC, (K)
	M18 x 1 	8,  <i>uprox</i> [®] +	—, PNP	10...30 VDC	200 DC, (K)
		8,  <i>uprox</i> [®] +	—, NPN	10...30 VDC	200 DC, (K)
		8,  <i>uprox</i> [®] +	—, PNP	10...30 VDC	200 DC, (K)
		8,  Sn +	—, PNP	10...30 VDC	200 DC, (K)
		8,  Sn +	—, PNP	10...65 VDC	200 DC, (K)
		8,  Sn +	—, NPN	10...30 VDC	200 DC, (K)
		8,  Sn +	—, NPN	10...65 VDC	200 DC, (K)
		7,  -	—, 2-wire	10...65 VDC	100 DC, (K)
		5,  <i>uprox</i> [®]	—, PNP	10...30 VDC	200 DC, (K)
		5,  <i>uprox</i> [®]	—, NPN	10...30 VDC	200 DC, (K)
		5,  (Ex) II 2 G SIL2	NAMUR	nom. 8.2 VDC	-
		5,  -	—, PNP	10...30 VDC	200 DC, (K)
		5,  -	—, PNP	10...65 VDC	200 DC, (K)
		5,  -	—, NPN	10...30 VDC	200 DC, (K)
		5,  -	—, NPN	10...65 VDC	200 DC, (K)
5,  -	—, 2-wire	10...65 VDC	100 DC, (K)		
8,  Sn +	—, NPN	10...30 VDC	200 DC, (K)		
8,  Sn +	—, PNP	10...30 VDC	200 DC, (K)		
	M18 x 1 	5,  <i>uprox</i> [®]	—, PNP	10...30 VDC	200 DC, (K)
		5,  <i>uprox</i> [®]	—, NPN	10...30 VDC	200 DC, (K)
		12,  <i>uprox</i> [®]	—, PNP	10...30 VDC	200 DC, (K)
		12,  <i>uprox</i> [®]	—, NPN	10...30 VDC	200 DC, (K)

型号	订货号	连接方式 (☞ 322)	开关频率 [kHz]	温度范围 [°C]	防护等级	外壳 (☞ 334)	感应面 (☞ 334)	导线 (☞ 334)	LED U _B	LED ┌
BI5U-T18-AP6X2-H1141	1635136 ✕	S002	2	-30...+85	IP68	PBT	PBT	-	•	•
BI8-M18K-AP6X-H1141	4615050 ✕	S002	0.5	-25...+70	IP67	CuZn-Cr	PA	-	-	•
BI8U-M18-AP6X-H1141	1644731 ✕	S002	1.5	-30...+85	IP68	CuZn-Cr	LCP	-	-	•
BI8U-M18-AN6X-H1141	1644737 ✕	S005	1.5	-30...+85	IP68	CuZn-Cr	LCP	-	-	•
BI8U-M18-RP6X-H1141	1644750 ✕	S056	1.5	-30...+85	IP68	CuZn-Cr	LCP	-	-	•
BI8-M18-AP6X-H1141	46150 ✕	S002	0.5	-25...+70	IP67	CuZn-Cr	PA	-	-	•
BI8-M18-VP4X-H1141	4590701	S008	0.5	-25...+70	IP67	CuZn-Cr	PA	-	-	•
BI8-M18-AN6X-H1141	4615100	S005	0.5	-25...+70	IP67	CuZn-Cr	PA	-	-	•
BI8-M18-VN4X-H1141	4590702	S011	0.5	-25...+70	IP67	CuZn-Cr	PA	-	-	•
BI7-M18-AD4X-H1141	4414541 ✕	S014	1	-25...+70	IP67	CuZn-Cr	PA	-	-	•
BI5U-M18-AP6X-H1141	1635140 ✕	S002	1.5	-30...+85	IP67	CuZn-Cr	PBT	-	-	•
BI5U-M18-AN6X-H1141	1635150 ✕	S005	1.5	-30...+85	IP67	CuZn-Cr	PBT	-	-	•
BI5-M18-Y1X-H1141	40152 ✕	S026	1	-25...+70	IP67	CuZn-Cr	PBT	-	-	•
BI5-M18-AP6X-H1141	46145 ✕	S002	0.5	-25...+70	IP67	CuZn-Cr	PA	-	-	•
BI5-M18-VP4X-H1141	15618 ✕	S008	0.5	-25...+70	IP67	CuZn-Cr	PA	-	-	•
BI5-M18-AN6X-H1141	46146 ✕	S005	0.5	-25...+70	IP67	CuZn-Cr	PA	-	-	•
BI5-M18-VN4X-H1141	15718 ✕	S011	0.5	-25...+70	IP67	CuZn-Cr	PA	-	-	•
BI5-M18-AD4X-H1141	44145 ✕	S014	1	-25...+70	IP67	CuZn-Cr	PA	-	-	•
BI8-M18-VN6X-H1141	4605157	S011	0.5	-25...+70	IP67	CuZn-Cr	PA	-	-	•
BI8-M18-VP6X-H1141	4605156	S008	0.5	-25...+70	IP67	CuZn-Cr	PA	-	-	•
BI5U-S18-AP6X-H1141	1635600 ✕	S002	2.5	-30...+85	IP68	PBT	PBT	-	-	•
BI5U-S18-AN6X-H1141	1635620	S005	2.5	-30...+85	IP68	PBT	PBT	-	-	•
NI12U-S18-AP6X-H1141	1645600 ✕	S002	2	-30...+85	IP68	PBT	PBT	-	-	•
NI12U-S18-AN6X-H1141	1645620	S005	2	-30...+85	IP68	PBT	PBT	-	-	•











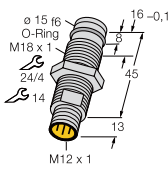



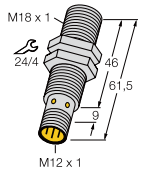







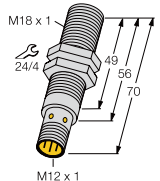

✕ = 优选型号

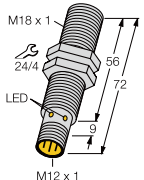
型号	订货号	连接方式 (☞ 322)	开关频率 [kHz]	温度范围 [°C]	防护等级	外壳 (☞ 334)	感应面 (☞ 334)	导线 (☞ 334)	LED U _B	LED ┘
BI8U-MT18-AP6X-H1141	1644730 ✕	S002	1.5	-30...+85	IP68	CuZn-T	LCP	-	-	•
BI8U-EM18-AP6X-H1141	1644734 ✕	S002	1.5	-30...+85	IP68	V2A	LCP	-	-	•
BI8U-EM18WD-AP6X-H1141	1634816 ✕	S002	1.5	-40...+100	IP68 / IP69K	VA	LCP	-	-	•
BI8U-EM18WD-AP6X-H1141/3GD	1634853 ✕	S002	1.5	-40...+100	IP68 / IP69K	VA	LCP	-	-	•
BI8U-MT18-AN6X-H1141	1644739	S005	1.5	-30...+85	IP68	CuZn-T	LCP	-	-	•
BI8U-EM18-AN6X-H1141	1644738	S005	1.5	-30...+85	IP68	V2A	LCP	-	-	•
BI8U-EM18WD-AN6X-H1141	1634839	S005	1.5	-40...+100	IP68 / IP69K	VA	LCP	-	-	•
BI8U-EM18WD-AN6X-H1141/3GD	1634854	S005	1.5	-40...+100	IP68 / IP69K	VA	LCP	-	-	•
BI5U-EM18-AP6X-H1141	1635340 ✕	S002	2.5	-30...+85	IP68	VA	PBT	-	-	•
BI5U-MT18-AP6X-H1141	1635240 ✕	S002	1.5	-30...+85	IP67	CuZn-T	PBT	-	-	•
BI5U-EM18-AN6X-H1141	1635350 ✕	S005	2.5	-30...+85	IP68	VA	PBT	-	-	•
BI5U-MT18-AN6X-H1141	1635250	S005	1.5	-30...+85	IP67	CuZn-T	PBT	-	-	•
BI5-EM18-Y1X-H1141	4015202 ✕	S026	1	-25...+70	IP67	VA	PA	-	-	•
BI5-EG18SK-Y1X	4012060 ✕	S027	1	-25...+70	IP67	VA	PA	-	-	•
BI5-S18-AP6X-H1141	46524 ✕	S002	1	-25...+70	IP67	PA	PA	-	-	•
BI5-S18-AN6X-H1141	46525	S005	0.5	-25...+70	IP67	PA	PA	-	-	•
NI8-S18-AP6X-H1141	46526 ✕	S002	0.5	-25...+70	IP67	PA	PA	-	-	•
NI8-S18-AN6X-H1141	46527 ✕	S005	0.5	-25...+70	IP67	PA	PA	-	-	•

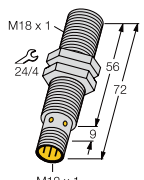
✕ = 优选型号













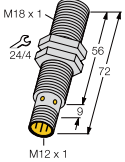

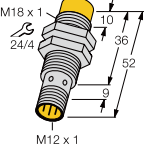



































电感式传感器

尺寸/外形	特性	额定工作距离Sn [mm]	输出	工作电压	额定工作电流I _e [mA]	
	M18 x 1	500 bar	2, 	—, PNP	10...30 VDC	200 DC, (K)
		100 bar	2, 	—, PNP	10...30 VDC	200 DC, (K)
	M18 x 1	<i>uprox</i> [®] + 15 bar	8, 	—, PNP	10...55 VDC	200 DC, (K)
		<i>uprox</i> [®] + wash down	8, 	—, PNP	10...55 VDC	200 DC, (K)
		15 bar	8, 	—, NPN	10...55 VDC	200 DC, (K)
		<i>uprox</i> [®] + wash down				
		<i>uprox</i> [®] +	8, 	—, NPN	10...55 VDC	200 DC, (K)
		<i>uprox</i> [®]	5, 	—, PNP	10...65 VDC	200 DC, (K)
		<i>uprox</i> [®]	5, 	—, NPN	10...65 VDC	200 DC, (K)
		<i>uprox</i> [®] +	5, 	—, 2-wire	10...65 VDC	100 DC, (K)
	<i>uprox</i> [®] +	5, 	—, 2-wire	10...65 VDC	100 DC, (K)	
	M18 x 1	选择型FE	5, 	—, PNP	10...30 VDC	200 DC, (K)
						
	M18 x 1	Sn +	8, 	—, PNP	10...30 VDC	200 DC, (K)
						
	M18 x 1	PTFE <i>uprox</i> [®] +	8, 	—, PNP	10...30 VDC	200 DC, (K)
		PTFE <i>uprox</i> [®] +	8, 	—, PNP	10...30 VDC	200 DC, (K)
		PTFE <i>uprox</i> [®]	5, 	—, PNP	10...30 VDC	200 DC, (K)
		-	5, 	—, PNP	10...65 VDC	200 DC, (K)
		harsh 选择型NF	5, 	—, PNP	10...30 VDC	200 DC, (K)

型号	订货号	连接方式 (☞ 322)	开关频率 [kHz]	温度范围 [°C]	防护等级	外壳 (☞ 334)	感应面 (☞ 334)	导线 (☞ 334)	LED U _B	LED ┌
BID2-G180-AP6-H1141/S212	16885 ✕	S002	2	-25...+70	IP67	VA	PA	-	-	-
BID2-G180-AP6-H1141/S220	1688501	S002	2	-25...+70	IP67	VA	PA	-	-	-
BI8U-M18M-VP44X-H1141	1634877 ✕	S008	1.5	-30...+85	IP68	CuZn-Cr	LCP	-	-	•
BI8U-EM18MWD-VP44X-H1141	1634897	S008	1.5	-30...+85	IP68 / IP69K	VA	LCP	-	-	•
BI8U-EM18MWD-VN44X-H1141	1635127	S011	1.5	-30...+85	IP68 / IP69K	V4A	LCP	-	-	•
BI8U-M18M-VN44X-H1141	1634881 ✕	S011	1.5	-30...+85	IP68	CuZn-Cr	LCP	-	-	•
BI5U-M18M-VP4X-H1141	1581255 ✕	S008	1.5	-30...+85	IP67	CuZn-Cr	PBT	-	-	•
BI5U-M18M-VN4X-H1141	1581311	S011	1.5	-30...+85	IP67	CuZn-Cr	PBT	-	-	•
BI5U-M18M-AD4X-H1144	4405066 ✕	S100	0.01	-25...+70	IP68	CuZn-Cr	LCP	-	-	•
BI5U-MT18M-AD4X-H1141	4405068 ✕	S100	0.01	-25...+70	IP68	CuZn-Cr	LCP	-	-	•
BI5FE-M18FE-AP6X-H1141	1615009 ✕	S002	0.025	0...+60	IP67	CuZn-OP	VA	-	-	•
BI8-M18-AP6X-H1141/S58	4615004 ✕	S002	0.5	-25...+70	IP67	CuZn-Cr	PA	-	-	•
BI8U-MT18E-AP6X-H1141	1644752	S002	1.5	-30...+85	IP68	CuZn-T	LCP	-	-	•
BI8U-EM18E-AP6X-H1141	1634865	S002	1.5	-30...+85	IP68	V2A	LCP	-	-	•
BI5U-MT18E-AP6X-H1141	1635248 ✕	S002	2.5	-30...+85	IP67	CuZn-T	PBT	-	-	•
BI5-M18E-VP4X-H1141	1561811 ✕	S008	0.5	-25...+70	IP67	CuZn-Cr	PA	-	-	•
BI5NF-EM18HE-AP6X2-H1141	1615000 ✕	S002	2.5	0...+60	IP67	VA	DURO	-	•	•

✕ = 优选型号

电感式传感器











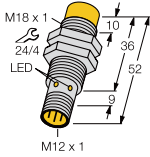













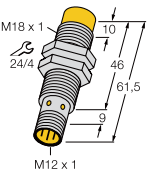





















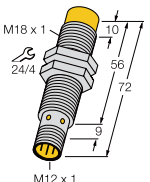









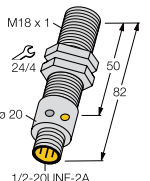

尺寸/外形	特性	额定工作距离Sn [mm]	输出	工作电压	额定工作电流I _e [mA]	
	M18 x 1	5, 	—, NPN	10...30 VDC	200 DC, (K)	
		harsh 选择型NF				
	M18 x 1	15, 	—, PNP	10...30 VDC	200 DC, (K)	
		PTFE uprox [®] +				
		uprox [®] +	15, 	—, PNP	10...30 VDC	200 DC, (K)
		Ex II 3 D 15 bar uprox [®] +	15, 	—, PNP	10...30 VDC	200 DC, (K)
		15 bar uprox [®] +	15, 	—, PNP	10...30 VDC	200 DC, (K)
		uprox [®] +	15, 	—, PNP	10...30 VDC	200 DC, (K)
		uprox [®] +	15, 	—, PNP	10...30 VDC	200 DC, (K)
		PTFE uprox [®] +	15, 	—, NPN	10...30 VDC	200 DC, (K)
		uprox [®] +	15, 	—, NPN	10...30 VDC	200 DC, (K)
		uprox [®] +	15, 	—, NPN	10...30 VDC	200 DC, (K)
		Ex II 3 D 15 bar uprox [®] +	15, 	—, NPN	10...30 VDC	200 DC, (K)
		15 bar uprox [®] +	15, 	—, NPN	10...30 VDC	200 DC, (K)
		uprox [®]	12, 	—, PNP	10...30 VDC	200 DC, (K)
		PTFE uprox [®]	12, 	—, PNP	10...30 VDC	200 DC, (K)
		uprox [®]	12, 	—, PNP	10...30 VDC	200 DC, (K)
		uprox [®]	12, 	—, NPN	10...30 VDC	200 DC, (K)
		PTFE uprox [®]	12, 	—, NPN	10...30 VDC	200 DC, (K)
		uprox [®]	12, 	—, NPN	10...30 VDC	200 DC, (K)
		Ex II 2 G SIL2	10, 	NAMUR	nom. 8.2 VDC	—
		Ex II 1 G Ex II 1 D SIL2	10, 	NAMUR	nom. 8.2 VDC	—
	—	8, 	—, PNP	10...30 VDC	200 DC, (K)	
	Sn +	14, 	—, PNP	10...30 VDC	200 DC, (K)	
	—	8, 	—, NPN	10...30 VDC	200 DC, (K)	
	Sn +	14, 	—, NPN	10...30 VDC	200 DC, (K)	

型号	订货号	连接方式 (☞ 322)	开关频率 [kHz]	温度范围 [°C]	防护等级	外壳 (☞ 334)	感应面 (☞ 334)	导线 (☞ 334)	LED U _B	LED ┌
BI5NF-EM18HE-AN6X2-H1141	1615004	S005	2.5	0...+60	IP67	VA	DURO	-	•	•
NI15U-MT18-AP6X-H1141	1635333 ✘	S002	1.5	-30...+85	IP68	CuZn-T	LCP	-	-	•
NI15U-M18-AP6X-H1141	1635331 ✘	S002	1.5	-30...+85	IP68	CuZn-Cr	LCP	-	-	•
NI15U-EM18WD-AP6X-H1141/3D	1634859 ✘	S002	1.5	-40...+100	IP68 / IP69K	VA	LCP	-	-	•
NI15U-EM18WD-AP6X-H1141	1634818 ✘	S002	1.5	-40...+100	IP68 / IP69K	VA	LCP	-	-	•
NI15U-EM18-AP6X-H1141	1635332 ✘	S002	1.5	-30...+85	IP68	V2A	LCP	-	-	•
NI15U-M18-RP6X-H1141	1635450 ✘	S056	1.5	-30...+85	IP68	CuZn-Cr	LCP	-	-	•
NI15U-MT18-AN6X-H1141	1635337	S005	1.5	-30...+85	IP68	CuZn-T	LCP	-	-	•
NI15U-M18-AN6X-H1141	1635335 ✘	S005	1.5	-30...+85	IP68	CuZn-Cr	LCP	-	-	•
NI15U-EM18-AN6X-H1141	1635336 ✘	S005	1.5	-30...+85	IP68	V2A	LCP	-	-	•
NI15U-EM18WD-AN6X-H1141/3D	1634860	S005	1.5	-40...+100	IP68 / IP69K	VA	LCP	-	-	•
NI15U-EM18WD-AN6X-H1141	1634835	S005	1.5	-40...+100	IP68 / IP69K	VA	LCP	-	-	•
NI12U-EM18-AP6X-H1141	1645340 ✘	S002	2	-30...+85	IP68	VA	PBT	-	-	•
NI12U-MT18-AP6X-H1141	1645240 ✘	S002	1.5	-30...+85	IP67	CuZn-T	PBT	-	-	•
NI12U-M18-AP6X-H1141	1645140 ✘	S002	1.5	-30...+85	IP67	CuZn-Cr	PBT	-	-	•
NI12U-EM18-AN6X-H1141	1645350 ✘	S005	2	-30...+85	IP68	VA	PBT	-	-	•
NI12U-MT18-AN6X-H1141	1645250 ✘	S005	1.5	-30...+85	IP67	CuZn-T	PBT	-	-	•
NI12U-M18-AN6X-H1141	1645150 ✘	S005	1.5	-30...+85	IP67	CuZn-Cr	PBT	-	-	•
NI10-M18-Y1X-H1141	40153 ✘	S026	0.5	-25...+70	IP67	CuZn-Cr	PBT	-	-	•
NI10-EM18-Y1X-H1141	1006261 ✘	S026	0.5	-25...+70	IP67	VA	PBT	-	-	•
NI8-M18-AP6X-H1141	46147 ✘	S002	0.5	-25...+70	IP67	CuZn-Cr	PA	-	-	•
NI14-M18-AP6X-H1141	4611400 ✘	S002	0.5	-25...+70	IP67	CuZn-Cr	PA	-	-	•
NI8-M18-AN6X-H1141	46148 ✘	S005	0.5	-25...+70	IP67	CuZn-Cr	PA	-	-	•
NI14-M18-AN6X-H1141	4611410 ✘	S005	0.5	-25...+70	IP67	CuZn-Cr	PA	-	-	•

✘ = 优选型号

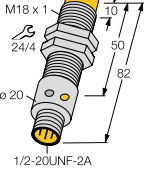
2











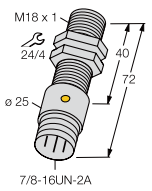

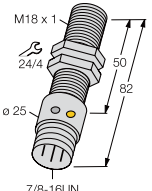

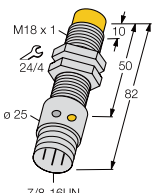

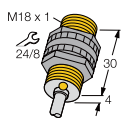





电感式传感器

尺寸/外形	特性	额定工作距离 Sn [mm]	输出	工作电压	额定工作电流 I _e [mA]
	M18 x 1	8, 	 , NPN	10...65 VDC	200 DC, 
		14, 	 , NPN	10...30 VDC	200 DC, 
	-	8, 	 , 2-wire	10...65 VDC	100 DC, 
	Sn +	14, 	 , PNP	10...30 VDC	200 DC, 
	M18 x 1	<i>uprox</i> [®] + 15, 	 , PNP	10...55 VDC	200 DC, 
		15 bar <i>uprox</i> [®] + wash down	 , PNP	10...55 VDC	200 DC, 
	-	<i>uprox</i> [®] + 15, 	 , NPN	10...55 VDC	200 DC, 
	-	<i>uprox</i> [®] 12, 	 , PNP	10...65 VDC	200 DC, 
	-	<i>uprox</i> [®] 12, 	 , NPN	10...65 VDC	200 DC, 
	-	<i>uprox</i> [®] + 10, 	 , 2-wire	10...65 VDC	100 DC, 
	-	<i>uprox</i> [®] + 10, 	 , 2-wire	10...65 VDC	100 DC, 
	M18 x 1	<i>uprox</i> [®] 12, 	 , PNP	10...30 VDC	200 DC, 
		<i>uprox</i> [®] + 15, 	 , PNP	10...30 VDC	200 DC, 
	-	<i>uprox</i> [®] + 15, 	 , NPN	10...30 VDC	200 DC, 
	-	<i>uprox</i> [®] + 15, 	 , PNP	10...30 VDC	200 DC, 
	M18 x 1	<i>uprox</i> [®] 5, 		20...250 VAC 10...300 VDC	400 AC 300 DC, 
	M18 x 1	<i>uprox</i> [®] 12, 		20...250 VAC 10...300 VDC	400 AC 300 DC, 

型号	订货号	连接方式 (☞ 322)	开关频率 [kHz]	温度范围 [°C]	防护等级	外壳 (☞ 334)	感应面 (☞ 334)	导线 (☞ 334)	LED U _B	LED ┘
NI8-M18-VN4X-H1141	15719 ✕	S011	0.5	-25...+70	IP67	CuZn-Cr	PA	-	-	•
NI14-M18-VN6X-H1141	4690630 ✕	S011	0.5	-25...+70	IP67	CuZn-Cr	PA	-	-	•
NI8-M18-AD4X-H1141	44147 ✕	S014	0.5	-25...+70	IP67	CuZn-Cr	PA	-	-	•
NI14-M18-VP6X-H1141	4590620 ✕	S008	0.5	-25...+70	IP67	CuZn-Cr	PA	-	-	•
NI15U-M18M-VP44X-H1141	1634879 ✕	S008	1.5	-30...+85	IP68	CuZn-Cr	LCP	-	-	•
NI15U-EM18MWD-VP44X-H1141	1634898	S008	1.5	-30...+85	IP68 / IP69K	VA	LCP	-	-	•
NI15U-M18M-VN44X-H1141	1634883 ✕	S011	1.5	-30...+85	IP68	CuZn-Cr	LCP	-	-	•
NI12U-M18M-VP4X-H1141	1581458 ✕	S008	1.5	-30...+85	IP67	CuZn-Cr	PBT	-	-	•
NI12U-M18M-VN4X-H1141	1581552 ✕	S011	1.5	-30...+85	IP67	CuZn-Cr	PBT	-	-	•
NI10U-M18M-AD4X-H1141	4405069 ✕	S014	0.01	-25...+70	IP68	CuZn-Cr	LCP	-	-	•
NI10U-MT18M-AD4X-H1141	4405071 ✕	S014	0.01	-25...+70	IP68	CuZn-T	LCP	-	-	•
NI12U-M18E-AP6X-H1141	1645143 ✕	S002	1.5	-30...+85	IP67	CuZn-Cr	PBT	-	-	•
NI15U-EM18E-AP6X-H1141	1635372 ✕	S002	1.5	-30...+85	IP68	V2A	LCP	-	-	•
NI15U-M18E-AN6X-H1141	1635353 ✕	S005	1.5	-30...+85	IP68	CuZn-Cr	LCP	-	-	•
NI15U-M18E-AP6X-H1141	1635352 ✕	S002	1.5	-30...+85	IP68	CuZn-Cr	LCP	-	-	•
BI5U-G18-ADZ30X2-B3331	4281213	S153	0.02	-30...+85	IP67	CuZn-Cr	PBT	-	•	•
NI12U-G18-ADZ30X2-B3331	4281413	S153	0.02	-30...+85	IP67	CuZn-Cr	PA	-	•	•

✕ = 优选型号











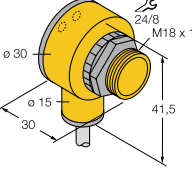



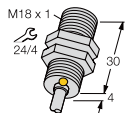









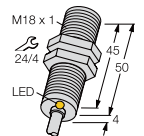























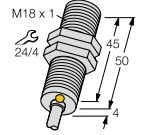

电感式传感器

尺寸/外形	特性	额定工作距离Sn [mm]	输出	工作电压	额定工作电流I _e [mA]	
	M18 x 1 	-	-	10...30 VDC	200 DC, (K)	
		-	-	10...30 VDC	200 DC, (K)	
	M18 x 1 	<i>uprox</i> [®]	-	20...250 VAC 10...300 VDC	400 AC 300 DC, (K)	
	M18 x 1 	<i>uprox</i> [®]	-	20...250 VAC 10...300 VDC	400 AC 300 DC, (K)	
	M18 x 1 	 II 2 G SIL2	5, 	NAMUR	nom. 8.2 VDC	-
		 II 2 G SIL2 T -40 °C	5, 	NAMUR	nom. 8.2 VDC	-
		 II 2 G SIL2 T +100 °C	5, 	NAMUR	nom. 8.2 VDC	-
		 II 2 G SIL2	10, 	NAMUR	nom. 8.2 VDC	-
		 II 2 G SIL2 T -40 °C	10, 	NAMUR	nom. 8.2 VDC	-
		 II 2 G SIL2 T +100 °C	10, 	NAMUR	nom. 8.2 VDC	-
		 II 2 G SIL2	10, 	NAMUR	nom. 8.2 VDC	-

型号	订货号	连接方式 (☞ 322)	开关频率 [kHz]	温度范围 [°C]	防护等级	外壳 (☞ 334)	感应面 (☞ 334)	导线 (☞ 334)	LED U _B	LED ┌
BI5-G18-AP6X-B1341	46963 ✘	S002	0.5	-25...+70	IP67	CuZn-Cr	PA	-	-	•
BI5-G18-AN6X-B1341	46952 ✘	S005	0.5	-25...+70	IP67	CuZn-Cr	PA	-	-	•
BI5U-G18-ADZ30X2-B1331	4281212 ✘	S153	0.02	-30...+85	IP67	CuZn-Cr	PBT	-	•	•
NI12U-G18-ADZ30X2-B1331	4281412 ✘	S153	0.02	-30...+85	IP67	CuZn-Cr	PBT	-	•	•
BI5-P18-Y1X	40350 ✘	S025	1	-25...+70	IP67	PA	PA	PVC 2 m	-	•
BI5-P18-Y1X/S97	4035001	S025	1	-40...+70	IP67	PA	PA	Silic. 2 m	-	•
BI5-P18-Y1/S100	10245 ✘	S025	1	-25...+100	IP67	PA	PA	PVC 2 m	-	-
NI10-P18-Y1X	40351 ✘	S025	0.5	-25...+70	IP67	PA	PA	PVC 2 m	-	•
NI10-P18-Y1X/S97	4035121	S025	0.5	-40...+70	IP67	PA	PA	Silic. 2 m	-	•
NI10-P18-Y1/S100	10317 ✘	S025	0.5	-25...+100	IP67	PA	PA	PVC 2 m	-	-

✘ = 优选型号











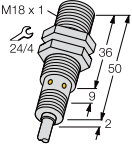







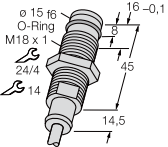







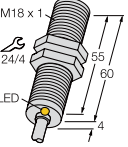



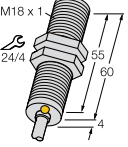











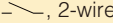



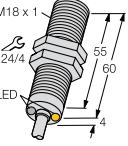

电感式传感器

尺寸/外形	特性	额定工作距离Sn [mm]	输出	工作电压	额定工作电流Ie [mA]	
	M18 x 1 	<i>uprox</i> [®] 5, 	 , PNP	10...30 VDC	200 DC, (K)	
	M18 x 1 	- 7,  Ex II 2 G SIL2 5,  Ex II 1 G 5,  Ex II 1 D SIL2 T +100 °C - 5,  - 5, 	 , 2-wire NAMUR NAMUR  , PNP  , NPN	10...65 VDC nom. 8.2 VDC nom. 8.2 VDC 10...30 VDC 10...30 VDC	100 DC, (K) - - 200 DC, (K) 200 DC, (K)	
	M18 x 1 	<i>uprox</i> [®] + <i>uprox</i> [®] + - <i>uprox</i> [®] <i>uprox</i> [®] - T +100 °C - - - - Sn + Sn +	8,  8,  7,  5,  5,  5,  5,  5,  5,  5,  5,  8,  8, 	 , PNP            	10...30 VDC 10...30 VDC 10...65 VDC 10...30 VDC 10...30 VDC 10...30 VDC 10...65 VDC 10...30 VDC 10...65 VDC 10...65 VDC 10...30 VDC 10...30 VDC	200 DC, (K) 200 DC, (K) 100 DC, (K) 200 DC, (K) 200 DC, (K) 200 DC, (K) 200 DC, (K) 200 DC, (K) 200 DC, (K) 200 DC, (K) 100 DC, (K) 200 DC, (K) 200 DC, (K)
	M18 x 1 	<i>uprox</i> [®] <i>uprox</i> [®] - - Sn + Sn +	     	10...30 VDC 10...30 VDC 10...65 VDC 10...65 VDC 10...30 VDC 10...30 VDC	200 DC, (K) 200 DC, (K) 200 DC, (K) 200 DC, (K) 200 DC, (K) 200 DC, (K)	

型号	订货号	连接方式 (☞ 322)	开关频率 [kHz]	温度范围 [°C]	防护等级	外壳 (☞ 334)	感应面 (☞ 334)	导线 (☞ 334)	LED U _B	LED ┘
BI5U-T18-AP6X2/S90	1635135 ✕	S001	2	-30...+85	IP68	PBT	PBT	PUR 2 m	•	•
BI7-G18K-AD4X	4414540 ✕	S013	0.5	-25...+70	IP67	CuZn-Cr	PA	PVC 2 m	-	•
BI5-G18-Y1X	40150 ✕	S025	1	-25...+70	IP67	CuZn-Cr	PA	PVC 2 m	-	•
BI5-EG18-Y1X/S100 7M	4012007 ✕	S025	1	-25...+100	IP67	VA	PA	PVC 7 m	-	•
BI5-G18K-AP6X	46704 ✕	S001	0.5	-25...+70	IP67	CuZn-Cr	PA	PVC 2 m	-	•
BI5-G18K-AN6X	46714	S004	0.5	-25...+70	IP67	CuZn-Cr	PA	PVC 2 m	-	•
BI8U-M18-AP6X	1644733 ✕	S001	1.5	-30...+85	IP68	CuZn-Cr	LCP	PVC 2 m	-	•
BI8U-M18-AN6X	1644736	S004	1.5	-30...+85	IP68	CuZn-Cr	LCP	PVC 2 m	-	•
BI7-M18-AD4X	4414535 ✕	S013	1	-25...+70	IP67	CuZn-Cr	PA	PVC 2 m	-	•
BI5U-M18-AP6X	1635100 ✕	S001	1.5	-30...+85	IP67	CuZn-Cr	PBT	PVC 2 m	-	•
BI5U-M18-AN6X	1635120 ✕	S004	1.5	-30...+85	IP67	CuZn-Cr	PBT	PVC 2 m	-	•
BI5-M18-AP6X	46110 ✕	S001	0.5	-25...+70	IP67	CuZn-Cr	PA	PVC 2 m	-	•
BI5-M18-AP6X/S100	4611004 ✕	S001	0.5	-25...+100	IP67	CuZn-Cr	PA-X	PVC 2 m	-	•
BI5-M18-VP4X	15611 ✕	S007	0.5	-25...+70	IP67	CuZn-Cr	PA	PVC 2 m	-	•
BI5-M18-AN6X	46111 ✕	S004	0.5	-25...+70	IP67	CuZn-Cr	PA	PVC 2 m	-	•
BI5-M18-VN4X	15711 ✕	S010	0.5	-25...+70	IP67	CuZn-Cr	PA	PVC 2 m	-	•
BI5-M18-AD4X	44110 ✕	S013	1	-25...+70	IP67	CuZn-Cr	PA	PVC 2 m	-	•
BI8-M18-AP6X	4615030 ✕	S001	0.5	-25...+70	IP67	CuZn-Cr	PA	PVC 2 m	-	•
BI8-M18-AN6X	4615130 ✕	S004	0.5	-25...+70	IP67	CuZn-Cr	PA	PVC 2 m	-	•
BI5U-EM18-AP6X	1635300 ✕	S001	2.5	-30...+85	IP68	VA	PBT	PVC 2 m	-	•
BI5U-EM18-AN6X	1635320 ✕	S004	2.5	-30...+85	IP68	VA	PBT	PVC 2 m	-	•
BI5-EM18-VP4X 7M	1561130 ✕	S007	0.5	-25...+70	IP67	VA	PA	PVC 7 m	-	•
BI5-EM18-VN4X 7M	1561131	S010	0.5	-25...+70	IP67	VA	PA	PVC 7 m	-	•
BI8-M18-VN6X	4605155 ✕	S010	0.5	-25...+70	IP67	CuZn-Cr	PA	PVC 2 m	-	•
BI8-M18-VP6X	4605154 ✕	S007	0.5	-25...+70	IP67	CuZn-Cr	PA	PVC 2 m	-	•

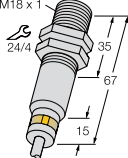
✕ = 优选型号











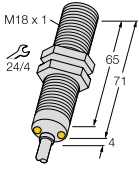













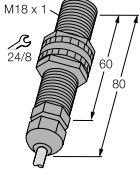





















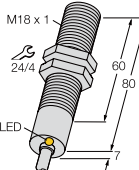





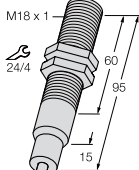

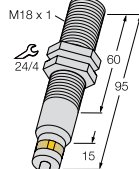

电感式传感器

尺寸/外形	特性	额定工作距离 S_n [mm]	输出	工作电压	额定工作电流 I_e [mA]	
	M18 x 1 	15 bar <i>uprox</i> [®] + wash down	8, 	 , PNP	10...30 VDC 200 DC, 	
		15 bar <i>uprox</i> [®] + wash down	8, 	 , NPN	10...30 VDC 200 DC, 	
	M18 x 1 	500 bar 100 bar	2,  2, 	 , PNP  , PNP	10...30 VDC 200 DC,  10...30 VDC 200 DC, 	
	M18 x 1 	-	5, 		20...250 VAC 400 AC 10...300 VDC 300 DC	
	M18 x 1 	<i>uprox</i> [®] + <i>uprox</i> [®] + <i>uprox</i> [®] <i>uprox</i> [®] <i>uprox</i> [®] + <i>uprox</i> [®] +	8,  8,  5,  5,  5,  8, 	 , PNP  , NPN  , PNP  , NPN  , 2-wire  , PNP	10...55 VDC 200 DC,  10...55 VDC 200 DC,  10...65 VDC 200 DC,  10...65 VDC 200 DC,  10...65 VDC 100 DC,  10...30 VDC 200 DC, 	
	M18 x 1 	<i>uprox</i> [®]	5, 		20...250 VAC 400 AC 10...300 VDC 300 DC, 	
	M18 x 1 	15 bar wash down T -60 °C	5, 	 , PNP	10...30 VDC 200 DC, 	

型号	订货号	连接方式 (☞ 322)	开关频率 [kHz]	温度范围 [°C]	防护等级	外壳 (☞ 334)	感应面 (☞ 334)	导线 (☞ 334)	LED U _B	LED ┌
BI8U-EM18WD-AP6X	1634815 ✕	S001	1.5	-40...+100	IP68 / IP69K		LCP	PP2m	-	•
BI8U-EM18WD-AN6X	1634840	S004	1.5	-40...+100	IP68 / IP69K	V4A	LCP	PVC 2 m	-	•
BID2-G180-AP6/S212	1688003 ✕	S001	2	-20...+85	IP67	V2A	PA	PVC 2 m	-	-
BID2-G180-AP6/S220	16880	S001	2	-25...+70	IP67	V2A	PA	PVC 2 m	-	-
BI5-M18-AZ3X	43104 ✕	S155	0.02	-25...+70	IP67	CuZn-Cr	PA	PVC 2 m	-	•
BI8U-M18M-VP44X	1634876 ✕	S007	1.5	-30...+85	IP68	CuZn-Cr	LCP	PVC 2 m	-	•
BI8U-M18M-VN44X	1634880	S010	1.5	-30...+85	IP68	CuZn-Cr	LCP	PVC 2 m	-	•
BI5U-M18M-VP4X	1581201 ✕	S007	1.5	-30...+85	IP67	CuZn-Cr	PBT	PVC 2 m	-	•
BI5U-M18M-VN4X	1581310	S010	1.5	-30...+85	IP67	CuZn-Cr	PBT	PVC 2 m	-	•
BI5U-M18M-AD4X	4405067	S013	0.01	-25...+70	IP68	CuZn-Cr	LCP	PVC 2 m	-	•
BI8U-M18E-AP6X	1644732	S001	1.5	-30...+85	IP68	CuZn-Cr	LCP	PVC 2 m	-	•
BI5U-M18-ADZ30X2	4282210 ✕	S155	0.02	-30...+85	IP67	CuZn-Cr	PBT	PVC 2 m	•	•
BI5-EM18WD-AP6X/S929	4614902	S001	1	-60...+60	IP68 / IP69K	V4A	PTFE	FEP 2 m	-	•

✕ = 优选型号











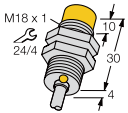















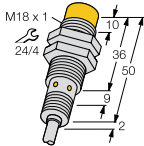







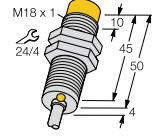







































电感式传感器

尺寸/外形	特性	额定工作距离Sn [mm]	输出	工作电压	额定工作电流Ie [mA]	
	M18 x 1 	转速监控	5, 	 , PNP	10...65 VDC	200 DC, 
		转速监控	5, 	 , PNP	10...65 VDC	200 DC, 
		转速监控	5, 	 , PNP	10...65 VDC	200 DC, 
		转速监控	5, 	 , PNP	10...65 VDC	200 DC, 
	M18 x 1 	水下 500m	5, 	 , PNP	10...30 VDC	200 DC, 
		水下 500m	5, 	 , NPN	10...30 VDC	200 DC, 
		水下 500m	5, 		20...250 VAC 10...300 VDC	400 AC 300 DC
			8, 	NAMUR	nom. 8.2 VDC	-
		水下 500m	8, 	 , PNP	10...30 VDC	200 DC, 
		水下 500m	8, 	 , NPN	10...30 VDC	200 DC, 
		水下 500m	8, 	 , NPN	10...30 VDC	200 DC, 
		水下 500m	8, 		20...250 VAC 10...300 VDC	400 AC 300 DC
	M18 x 1 	-	5, 	 , PNP	10...30 VDC	200 DC, 
		-	5, 		20...250 VAC	400 AC
	M18 x 1 	10 bar T +160 °C	5, 	 , PNP	10...30 VDC	200 DC, 
	M18 x 1 	uprox®+	8, 	 , PNP	10...30 VDC	200 DC, 
		uprox®+	8, 	 , NPN	10...30 VDC	200 DC, 
		T +120 °C wash down	5, 	 , PNP	10...30 VDC	200 DC, 

型号	订货号	连接方式 (☞ 322)	开关频率 [kHz]	温度范围 [°C]	防护等级	外壳 (☞ 334)	感应面 (☞ 334)	导线 (☞ 334)	LED U _B	LED ┘
DBI5U-M18E-AP4X3	1582236 ✕	S059	-	-30...+85	IP67	CuZn-Cr	PBT	PVC 2 m	•	•
DBI5U-M18E-AP4X2 500/MIN	1582229	S059	-	-30...+85	IP67	CuZn-Cr	PBT	PVC 2 m	•	•
DTBI5U-M18E-AP4X3	1582237 ✕	S059	-	-30...+85	IP67	CuZn-Cr	PBT	PVC 2 m	•	•
DBI5U-M18E-AP4X2 50/MIN	1582239 ✕	S059	-	-30...+85	IP67	CuZn-Cr	PBT	PVC 2 m	•	•
BI5-P18-AP6/S139-S90	1660350	S001	0.5	-25...+70	IP68	POM	POM	PUR 2 m	-	-
BI5-P18-AN6/S139-S90	1660351	S004	0.5	-25...+70	IP68	POM	POM	PUR 2 m	-	-
BI5-P18-AZ3/S139-S90	13843	S092	0.02	-25...+70	IP68	POM	POM	PUR 2 m	-	-
NI8-P18-Y1/S139	1072501	S025	1	-25...+70	IP68	POM	POM	PVC 2 m	-	-
NI8-P18-AP6/S139-S90	1650082	S001	0.5	-25...+70	IP68	POM	POM	PUR 2 m	-	-
NI8-P18-AN6/S139-S90	1650083	S004	0.5	-25...+70	IP68	POM	POM	PUR 2 m	-	-
NI8-P18-AN6/S139-S90 3M	1650205	S004	0.5	-25...+70	IP68	POM	POM	PUR 3 m	-	-
NI8-P18-AZ3/S139-S90	1350002	S092	0.02	-25...+70	IP68	POM	POM	PUR 2 m	-	-
BI5-M18-AP6X/S120	4611030 ✕	S001	0.1	-25...+120	IP67	CuZn-Cr	PA	Silic. 2 m	-	•
BI5-M18-AZ3X/S120	4310410 ✕	S092	0.02	-25...+120	IP67	CuZn-Cr	PA	PTFE 2 m	-	•
BI5-EM18-AP6/S907	4617425 ✕	S001	0.2	-25...+160	IP68 / IP69K	V4A	PEEK	PTFE 2 m	-	-
BI8U-M18E-AP6X-H1141	1644735 ✕	S002	1.5	-30...+85	IP68	CuZn-Cr	LCP	-	-	•
BI8U-M18E-AN6X-H1141	1644751	S005	1.5	-30...+85	IP68	CuZn-Cr	LCP	-	-	•
BI5-EM18D-VP6X/S120	4614900 ✕	S007	0.1	-25...+120	IP68 / IP69K	VA	PTFE	PTFE 2 m	-	•

✕ = 优选型号











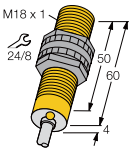









































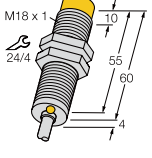





电感式传感器

尺寸/外形	特性	额定工作距离Sn [mm]	输出	工作电压	额定工作电流I _e [mA]	
	M18 x 1 	 II 2 G SIL2	14, 	NAMUR	nom. 8.2 VDC	-
		 II 1 G SIL2	10, 	NAMUR	nom. 8.2 VDC	-
		 II 1 D SIL2 T +100 °C	10, 	NAMUR	nom. 8.2 VDC	-
		 II 2 G SIL2	10, 	NAMUR	nom. 8.2 VDC	-
		-	10, 	 , PNP	10...30 VDC	200 DC, 
		-	10, 	 , NPN	10...30 VDC	200 DC, 
	M18 x 1 	15 bar <i>uprox</i> [®] wash down	15, 	 , PNP	10...30 VDC	200 DC, 
		15 bar <i>uprox</i> [®] wash down	15, 	 , NPN	10...30 VDC	200 DC, 
	M18 x 1 	<i>uprox</i> [®] ₊	15, 	 , PNP	10...30 VDC	200 DC, 
		<i>uprox</i> [®] ₊	15, 	 , NPN	10...30 VDC	200 DC, 
		<i>uprox</i> [®]	12, 	 , PNP	10...30 VDC	200 DC, 
		<i>uprox</i> [®]	12, 	 , PNP	10...30 VDC	200 DC, 
		<i>uprox</i> [®]	12, 	 , NPN	10...30 VDC	200 DC, 
		<i>uprox</i> [®]	12, 	 , NPN	10...30 VDC	200 DC, 
		-	8, 	 , PNP	10...30 VDC	200 DC, 
		-	8, 	 , PNP	10...65 VDC	200 DC, 
		Sn +	14, 	 , PNP	10...30 VDC	200 DC, 
		-	8, 	 , PNP	10...65 VDC	200 DC, 
		T +100 °C	8, 	 , PNP	10...30 VDC	200 DC, 
		-	8, 	 , NPN	10...30 VDC	200 DC, 
		-	8, 	 , NPN	10...65 VDC	200 DC, 
		Sn +	14, 	 , NPN	10...30 VDC	200 DC, 
		-	8, 	 , NPN	10...65 VDC	200 DC, 
-	8, 	 , 2-wire	10...65 VDC	100 DC, 		

型号	订货号	连接方式 (☞ 322)	开关频率 [kHz]	温度范围 [°C]	防护等级	外壳 (☞ 334)	感应面 (☞ 334)	导线 (☞ 334)	LED U _B	LED ┘
NI14-G18-Y1X	4015401	S025	0.5	-25...+70	IP67	CuZn-Cr	PA	PVC 2 m	-	•
NI10-EG18-Y1X/S100 7M	4012006 ✕	S025	0.5	-25...+100	IP67	VA	PA	PVC 7 m	-	•
NI10-G18-Y1X	40151 ✕	S025	0.5	-25...+70	IP67	CuZn-Cr	PA	PVC 2 m	-	•
NI10-G18K-AP6X	46705 ✕	S001	0.5	-25...+70	IP67	CuZn-Cr	PA	PVC 2 m	-	•
NI10-G18K-AN6X	46715	S004	0.5	-25...+70	IP67	CuZn-Cr	PA	PVC 2 m	-	•
NI15U-EM18WD-AP6X	1634817 ✕	S001	1.5	-40...+100	IP68 / IP69K	V4A	LCP	PP 2 m	-	•
NI15U-EM18WD-AN6X	1634836	S004	1.5	-40...+100	IP68 / IP69K	V4A	LCP	PP 2 m	-	•
NI15U-M18-AP6X	1635330 ✕	S001	1.5	-30...+85	IP68	CuZn-Cr	LCP	PVC 2 m	-	•
NI15U-M18-AN6X	1635334	S004	1.5	-30...+85	IP68	CuZn-Cr	LCP	PVC 2 m	-	•
NI12U-M18-AP6X	1645100 ✕	S001	1.5	-30...+85	IP67	CuZn-Cr	PBT	PVC 2 m	-	•
NI12U-EM18-AP6X	1645300 ✕	S001	2	-30...+85	IP68	VA	PBT	PVC 2 m	-	•
NI12U-M18-AN6X	1645120 ✕	S004	1.5	-30...+85	IP67	CuZn-Cr	LCP	PVC 2 m	-	•
NI12U-EM18-AN6X	1645320 ✕	S004	2	-30...+85	IP68	VA	PBT	PVC 2 m	-	•
NI8-M18-AP6X	46112 ✕	S001	0.5	-25...+70	IP67	CuZn-Cr	PA	PVC 2 m	-	•
NI8-M18-VP4X	15612 ✕	S007	0.5	-25...+70	IP67	CuZn-Cr	PA	PVC 2 m	-	•
NI14-M18-VP6X 7M	4590610 ✕	S007	0.5	-25...+70	IP67	CuZn-Cr	PA	PVC 7 m	-	•
NI8-EM18-VP4X 7M	1561133 ✕	S007	0.5	-25...+70	IP67	VA	PA	PVC 7 m	-	•
NI8-M18-AP6X/S100	4611201 ✕	S001	0.5	-25...+100	IP67	CuZn-Cr	PA-X	PVC 2 m	-	•
NI8-M18-AN6X	46113 ✕	S004	0.5	-25...+70	IP67	CuZn-Cr	PA	PVC 2 m	-	•
NI8-M18-VN4X	15712 ✕	S010	0.5	-25...+70	IP67	CuZn-Cr	PA	PVC 2 m	-	•
NI14-M18-VN6X 7M	4590609 ✕	S010	0.5	-25...+70	IP67	CuZn-Cr	PA	PVC 7 m	-	•
NI8-EM18-VN4X 7M	1561132	S010	0.5	-25...+70	IP67	VA	PA	PVC 7 m	-	•
NI8-M18-AD4X	44112 ✕	S013	0.5	-25...+70	IP67	CuZn-Cr	PA	PVC 2 m	-	•

✕ = 优选型号











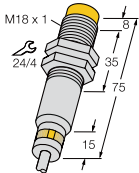



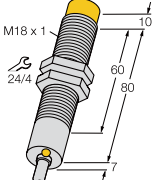





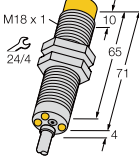







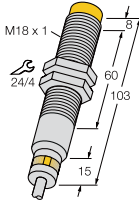







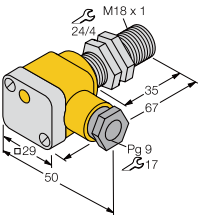

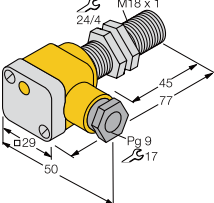









电感式传感器

尺寸/外形	特性	额定工作 距离Sn [mm]	输出	工作电压	额定工作 电流I _e [mA]	
	M18 x 1 	<i>uprox</i> [®]	5, 	 , PNP	10...30 VDC	200 DC, (K)
		<i>uprox</i> [®]	5, 	 , NPN	10...30 VDC	200 DC, (K)
		-	5, 	 , PNP	10...30 VDC	200 DC, (K)
		T -40 °C	5, 	 , PNP	10...65 VDC	200 DC, (K)
		T +100 °C	5, 	 , PNP	10...65 VDC	200 DC, (K)
		-	5, 	 , NPN	10...30 VDC	200 DC, (K)
		-	5, 	 , 2-wire	10...65 VDC	100 DC, (K)
		-	5, 		20...250 VAC 10...300 VDC	400 AC 300 DC
		T -40 °C	5, 		20...250 VAC 10...300 VDC	400 AC 300 DC
		T +100 °C	5, 		20...250 VAC 10...300 VDC	400 AC 300 DC
		<i>uprox</i> [®]	12, 	 , PNP	10...30 VDC	200 DC, (K)
		<i>uprox</i> [®]	12, 	 , NPN	10...30 VDC	200 DC, (K)
		-	8, 	 , PNP	10...30 VDC	200 DC, (K)
		T -40 °C	8, 	 , PNP	10...65 VDC	200 DC, (K)
		T +100 °C	8, 	 , PNP	10...65 VDC	200 DC, (K)
		-	8, 	 , NPN	10...30 VDC	200 DC, (K)
		-	8, 	 , 2-wire	10...65 VDC	100 DC, (K)
		-	8, 		20...250 VAC 10...300 VDC	400 AC 300 DC
		T -40 °C	8, 		20...250 VAC 10...300 VDC	400 AC 300 DC
		T +100 °C	8, 		20...250 VAC 10...300 VDC	400 AC 300 DC
	M18 x 1 	<i>uprox</i> ^{®+}	15, 	 , PNP	10...55 VDC	200 DC, (K)
		<i>uprox</i> ^{®+}	15, 	 , NPN	10...55 VDC	200 DC, (K)
		<i>uprox</i> [®]	12, 	 , PNP	10...65 VDC	200 DC, (K)
		<i>uprox</i> [®]	12, 	 , NPN	10...65 VDC	200 DC, (K)
		<i>uprox</i> [®]	12, 		20...250 VAC 10...300 VDC	400 AC 300 DC, (K)
		-	8, 		20...250 VAC 10...300 VDC	400 AC 300 DC
		<i>uprox</i> ^{®+}	10, 	 , 2-wire	10...65 VDC	100 DC, (K)

型号	订货号	连接方式 (☞ 322)	开关频率 [kHz]	温度范围 [°C]	防护等级	外壳 (☞ 334)	感应面 (☞ 334)	导线 (☞ 334)	LED U _B	LED ┘
BI5U-S18-AP6X	1635500 ✕	S001	2.5	-30...+85	IP68	PBT	PBT	PVC 2 m	-	•
BI5U-S18-AN6X	1635520	S004	2.5	-30...+85	IP68	PBT	PBT	PVC 2 m	-	•
BI5-S18-AP6X	46560 ✕	S001	1	-25...+70	IP67	PA	PA	PVC 2 m	-	•
BI5-S18-VP4X/S97	1513420	S007	0.5	-40...+70	IP67	PA	PA	Silic. 2 m	-	•
BI5-S18-VP4X/S100	1513402	S007	0.5	-25...+100	IP67	PA	PA	PVC 2 m	-	•
BI5-S18-AN6X	46561 ✕	S004	0.5	-25...+70	IP67	PA	PA	PVC 2 m	-	•
BI5-S18-AD4X	44560 ✕	S013	1	-25...+70	IP67	PA	PA	PVC 2 m	-	•
BI5-S18-AZ3X	43504 ✕	S092	0.02	-25...+70	IP67	PA	PA	PVC 2 m	-	•
BI5-S18-AZ3X/S97	1373410	S092	0.02	-40...+70	IP67	PA	PA	Silic. 2 m	-	•
BI5-S18-AZ3X/S100	13734 ✕	S092	0.02	-25...+100	IP67	PA	PA	PVC 2 m	-	•
NI12U-S18-AP6X	1645500 ✕	S001	2	-30...+85	IP68	PBT	PBT	PVC 2 m	-	•
NI12U-S18-AN6X	1645520	S004	2	-30...+85	IP68	PBT	PBT	PVC 2 m	-	•
NI8-S18-AP6X	46562 ✕	S001	0.5	-25...+70	IP67	PA	PA	PVC 2 m	-	•
NI8-S18-VP4X/S97	1513512	S007	0.5	-40...+70	IP67	PA	PA	Silic. 2 m	-	•
NI8-S18-VP4X/S100	1513510	S007	0.5	-25...+100	IP67	PA	PA	PVC 2 m	-	•
NI8-S18-AN6X	46563 ✕	S004	0.5	-25...+70	IP67	PA	PA	PVC 2 m	-	•
NI8-S18-AD4X	44562 ✕	S013	0.5	-25...+70	IP67	PA	PA	PVC 2 m	-	•
NI8-S18-AZ3X	43505 ✕	S092	0.02	-25...+70	IP67	PA	PA	PVC 2 m	-	•
NI8-S18-AZ3X/S97	1371803	S092	0.02	-40...+70	IP67	PA	PA	Silic. 2 m	-	•
NI8-S18-AZ3X/S100	13718 ✕	S092	0.02	-25...+100	IP67	PA	PA	PVC 2 m	-	•
NI15U-M18M-VP44X	1634878 ✕	S007	1.5	-30...+85	IP68	CuZn-Cr	LCP	PVC 2 m	-	•
NI15U-M18M-VN44X	1634882	S010	1.5	-30...+85	IP68	CuZn-Cr	LCP	PVC 2 m	-	•
NI12U-M18M-VP4X	1581403 ✕	S007	1.5	-30...+85	IP67	CuZn-Cr	PBT	PVC 2 m	-	•
NI12U-M18M-VN4X	1581501	S010	1.5	-30...+85	IP67	CuZn-Cr	PBT	PVC 2 m	-	•
NI12U-M18-ADZ30X2	4282410 ✕	S155	0.02	-30...+85	IP67	CuZn-Cr	PBT	PVC 2 m	•	•
NI8-M18-AZ3X	43105 ✕	S155	0.02	-25...+70	IP67	CuZn-Cr	PA	PVC 2 m	-	•
NI10U-M18-AD4X	4405070	S013	0.01	-25...+70	IP68	CuZn-Cr	LCP	PVC 2 m	-	•

✕ = 优选型号











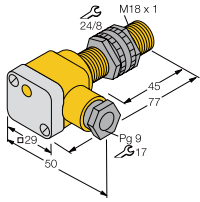











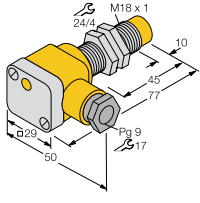







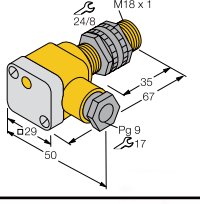



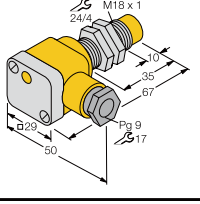

电感式传感器

尺寸/外形	特性	额定工作距离 S_n [mm]	输出	工作电压	额定工作电流 I_e [mA]
	M18 x 1  15 bar wash down T -60 °C	7, 	 , PNP	10...30 VDC	200 DC, 
	M18 x 1  T +120 °C T +120 °C	8,  8, 	 , PNP 	10...30 VDC 20...250 VAC	200 DC,  400 AC
	M18 x 1  转速监控 转速监控	12,  12, 	 , PNP  , PNP	10...65 VDC 10...65 VDC	200 DC,  200 DC, 
	M18 x 1  T +160 °C T +120 °C wash down	8,  7, 	 , PNP  , PNP	10...30 VDC 10...30 VDC	200 DC,  200 DC, 
	M18 x 1  Ex II 2 G SIL2	5, 	NAMUR	nom. 8.2 VDC	-
	M18 x 1  <i>uprox</i> [®] <i>uprox</i> [®] <i>uprox</i> [®] <i>uprox</i> [®] - -	5,  5,  5,  5,  5,  5, 	 , PNP  , PNP  , NPN  , NPN  , PNP  , NPN	10...30 VDC 10...65 VDC 10...30 VDC 10...65 VDC 10...30 VDC 10...30 VDC	200 DC,  200 DC,  200 DC,  200 DC,  200 DC,  200 DC, 

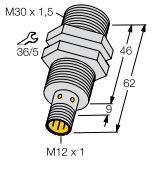
型号	订货号	连接方式 (☞ 322)	开关频率 [kHz]	温度范围 [°C]	防护等级	外壳 (☞ 334)	感应面 (☞ 334)	导线 (☞ 334)	LED U _B	LED ┌
NI7-EM18WD-AP6X/S929	4632001	S001	1	-60...+60	IP68 / IP69K	VA	PTFE	FEP 2 m	-	•
NI8-M18-AP6X/S120	4611230 ✘	S001	0.1	-25...+120	IP67	CuZn-Cr	PA	Silic. 2 m	-	•
NI8-M18-AZ3X/S120	4310530 ✘	S092	0.02	-25...+120	IP67	CuZn-Cr	PA	PTFE 2 m	-	•
DNI12U-M18E-AP4X3	1582235 ✘	S059	-	-30...+85	IP67	CuZn-Cr	PBT	PVC 2 m	•	•
DTNI12U-M18E-AP4X3	1582234 ✘	S059	-	-30...+85	IP67	CuZn-Cr	PBT	PVC 2 m	•	•
NI8-EM18-AP6/S907	4611231 ✘	S001	0.2	-25...+160	IP68 / IP69K	VA	PEEK	PTFE 2 m	-	-
NI7-EM18D-VP6X/S120	4632100 ✘	S007	0.1	-25...+120	IP68 / IP69K	VA	PTFE	PTFE 2 m	-	•
BI5-G18SK-Y1X	40160 ✘	S027	1	-25...+70	IP67	CuZn-Cr	PA	-	-	•
BI5U-EG18SK-AP6X	1635400 ✘	S003	2.5	-30...+85	IP68	VA	PBT	-	-	•
BI5U-EG18SK-VP4X	1581601 ✘	S009	2.5	-30...+85	IP68	VA	PBT	-	-	•
BI5U-EG18SK-AN6X	1635420	S006	2.5	-30...+85	IP68	VA	PBT	-	-	•
BI5U-EG18SK-VN4X	1581701	S012	2.5	-30...+85	IP68	VA	PBT	-	-	•
BI5-G18SK-AP6X	46420 ✘	S003	0.5	-25...+70	IP67	CuZn-Cr	PA	-	-	•
BI5-G18SK-AN6X	46421	S006	0.5	-25...+70	IP67	CuZn-Cr	PA	-	-	•

✘ = 优选型号











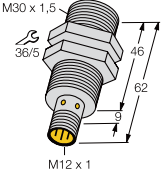



















































电感式传感器

尺寸/外形	特性	额定工作距离Sn [mm]	输出	工作电压	额定工作电流I _e [mA]	
	M18 x 1 	<i>uprox</i> [®]	5, 	—, PNP	10...30 VDC	200 DC, (K)
		<i>uprox</i> [®]	5, 	—, NPN	10...30 VDC	200 DC, (K)
		—	5, 	—, PNP	10...30 VDC	200 DC, (K)
		—	5, 	—, NPN	10...30 VDC	200 DC, (K)
		<i>uprox</i> [®]	12, 	—, PNP	10...30 VDC	200 DC, (K)
		<i>uprox</i> [®]	12, 	—, NPN	10...30 VDC	200 DC, (K)
		—	10, 	—, PNP	10...30 VDC	200 DC, (K)
—	10, 	—, NPN	10...30 VDC	200 DC, (K)		
		<i>uprox</i> [®] +	15, 	—, PNP	10...30 VDC	200 DC, (K)
	M18 x 1 	<i>uprox</i> [®]	12, 	—, PNP	10...30 VDC	200 DC, (K)
		<i>uprox</i> [®]	12, 	—, PNP	10...65 VDC	200 DC, (K)
		<i>uprox</i> [®]	12, 	—, NPN	10...30 VDC	200 DC, (K)
		<i>uprox</i> [®]	12, 	—, NPN	10...65 VDC	200 DC, (K)
		—	10, 	—, PNP	10...30 VDC	200 DC, (K)
—	10, 	—, NPN	10...30 VDC	200 DC, (K)		
	M18 x 1 	⊕ II 2 G SIL2	5, 	NAMUR	nom. 8.2 VDC	—
		⊕ II 2 G SIL2	10, 	NAMUR	nom. 8.2 VDC	—
		⊕ II 1 G ⊕ II 1 D SIL2 T+100°C 15 bar	10, 	NAMUR	nom. 8.2 VDC	—
	M18 x 1 	⊕ II 1 G ⊕ II 1 D SIL2	10, 	NAMUR	nom. 8.2 VDC	—
		⊕ II 2 G SIL2	10, 	NAMUR	nom. 8.2 VDC	—
	M30 x 1,5 	<i>uprox</i> [®] +	15, 	—, PNP	10...55 VDC	200 DC, (K)
		10 bar <i>uprox</i> [®] +	15, 	—, PNP	10...55 VDC	200 DC, (K)
		<i>uprox</i> [®] +	15, 	—, PNP	10...30 VDC	200 DC, (K)
		PTFE <i>uprox</i> [®] +	15, 	—, PNP	10...30 VDC	200 DC, (K)

型号	订货号	连接方式 (☞ 322)	开关频率 [kHz]	温度范围 [°C]	防护等级	外壳 (☞ 334)	感应面 (☞ 334)	导线 (☞ 334)	LED	LED
									U _B	┘
BI5U-P18SK-AP6X	1635700 ✕	S003	3	-30...+85	IP68	PBT	PBT	-	-	•
BI5U-P18SK-AN6X	1635720	S006	3	-30...+85	IP68	PBT	PBT	-	-	•
BI5-P18SK-AP6X	46565 ✕	S003	0.5	-25...+70	IP67	PA	PA	-	-	•
BI5-P18SK-AN6X	46566	S006	0.5	-25...+70	IP67	PA	PA	-	-	•
NI12U-P18SK-AP6X	1645700 ✕	S003	2	-30...+85	IP68	PBT	PBT	-	-	•
NI12U-P18SK-AN6X	1645720	S006	2	-30...+85	IP68	PBT	PBT	-	-	•
NI10-P18SK-AP6X	46567 ✕	S003	0.5	-25...+70	IP67	PA	PA	-	-	•
NI10-P18SK-AN6X	46568 ✕	S006	0.5	-25...+70	IP67	PA	PA	-	-	•
NI15U-EM18WDTC-AP6X	1634763 ✕	S003	1.5	-40...+100	IP68/IP69K	V4A	LCP	-	-	•
NI12U-EG18SK-AP6X	1645400 ✕	S003	2	-30...+85	IP68	VA	PBT	-	-	•
NI12U-EG18SK-VP4X	1581801 ✕	S009	2	-30...+85	IP68	VA	PBT	-	-	•
NI12U-EG18SK-AN6X	1645420	S006	2	-30...+85	IP68	VA	PBT	-	-	•
NI12U-EG18SK-VN4X	1581901	S012	2	-30...+85	IP68	VA	PBT	-	-	•
NI10-G18SK-AP6X	46422 ✕	S003	0.5	-25...+70	IP67	CuZn-Cr	PA	-	-	•
NI10-G18SK-AN6X	46423 ✕	S006	0.5	-25...+70	IP67	CuZn-Cr	PA	-	-	•
BI5-P18SK-Y1X	40360 ✕	S027	1	-25...+70	IP67	PA	PA	-	-	•
NI10-P18SK-Y1X	40361 ✕	S027	0.5	-25...+70	IP67	PA	PA	-	-	•
NI10-EM18WDTC-Y1X	4012151 ✕	S027	0.5	-40...+100	IP68/IP69K	V4A	LCP	-	-	•
NI10-EG18SK-Y1X	4012150 ✕	S027	0.5	-25...+70	IP67	VA	PA	-	-	•
NI10-G18SK-Y1X	40161 ✕	S027	0.5	-25...+70	IP67	CuZn-Cr	PA	-	-	•
BI15U-M30-VP44X-H1141	1634885 ✕	S008	1	-30...+85	IP68	CuZn-Cr	LCP	-	-	•
BI15U-EM30WD-VP44X-H1141	1634899	S008	0.75	-30...+85	IP68 / IP69K	VA	LCP	-	-	•
BI15U-M30-AP6X-H1141	1636732 ✕	S002	1	-30...+85	IP68	CuZn-Cr	LCP	-	-	•
BI15U-MT30-AP6X-H1141	1636734 ✕	S002	1	-30...+85	IP68	CuZn-T	LCP	-	-	•

✕ = 优选型号











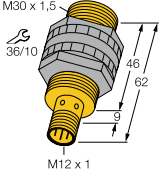













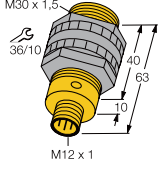





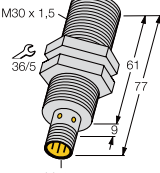







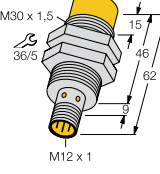

















电感式传感器

尺寸/外形	特性	额定工作 距离Sn [mm]	输出	工作电压	额定工作 电流I _e [mA]	
	M30 x 1,5 	10 bar <i>uproX</i> [®] + wash down	15, 	 , PNP	10...30 VDC	200 DC, (K)
		<i>uproX</i> [®] +	15, 	 , PNP	10...30 VDC	200 DC, (K)
		⊕ II 3 G ⊕ II 3 D 10 bar <i>uproX</i> [®] + wash down	15, 	 , PNP	10...30 VDC	200 DC, (K)
		<i>uproX</i> [®] +	15, 	 , PNP	10...30 VDC	200 DC, (K)
		<i>uproX</i> [®] +	15, 	 , NPN	10...30 VDC	200 DC, (K)
		PTFE <i>uproX</i> [®] +	15, 	 , NPN	10...30 VDC	200 DC, (K)
		10 bar <i>uproX</i> [®] + wash down	15, 	 , NPN	10...30 VDC	200 DC, (K)
		⊕ II 3 G ⊕ II 3 D 10 bar <i>uproX</i> [®] + wash down	15, 	 , NPN	10...30 VDC	200 DC, (K)
		<i>uproX</i> [®] +	15, 	 , NPN	10...55 VDC	200 DC, (K)
		Sn +	15, 	 , NPN	10...30 VDC	200 DC, (K)
		Sn +	15, 	 , PNP	10...30 VDC	200 DC, (K)
		Sn +	15, 	 , NPN	10...30 VDC	200 DC, (K)
		-	12, 	 , 2-wire	10...65 VDC	100 DC, (K)
		<i>uproX</i> [®]	10, 	 , PNP	10...30 VDC	200 DC, (K)
		<i>uproX</i> [®]	10, 	 , PNP	10...30 VDC	200 DC, (K)
		PTFE <i>uproX</i> [®]	10, 	 , PNP	10...30 VDC	200 DC, (K)
		<i>uproX</i> [®]	10, 	 , PNP	10...65 VDC	200 DC, (K)
		Sn +	15, 	 , PNP	10...30 VDC	200 DC, (K)
		<i>uproX</i> [®]	10, 	 , NPN	10...30 VDC	200 DC, (K)
		<i>uproX</i> [®]	10, 	 , NPN	10...30 VDC	200 DC, (K)
		PTFE <i>uproX</i> [®]	10, 	 , NPN	10...30 VDC	200 DC, (K)
		<i>uproX</i> [®]	10, 	 , NPN	10...65 VDC	200 DC, (K)
		⊕ II 2 G SIL2	10, 	NAMUR	nom. 8.2 VDC	-
		⊕ II 1 G ⊕ II 1 D SIL2		NAMUR	nom. 8.2 VDC	-
		-	10, 	 , PNP	10...30 VDC	200 DC, (K)
		-	10, 	 , PNP	10...65 VDC	200 DC, (K)
		-	10, 	 , NPN	10...30 VDC	200 DC, (K)
		-	10, 	 , NPN	10...65 VDC	200 DC, (K)
		-	10, 	 , 2-wire	10...65 VDC	100 DC, (K)
		<i>uproX</i> [®] +	10, 	 , 2-wire	10...65 VDC	100 DC, (K)
<i>uproX</i> [®] +	10, 	 , 2-wire	10...65 VDC	100 DC, (K)		

型号	订货号	连接方式 (☞ 322)	开关频率 [kHz]	温度范围 [°C]	防护等级	外壳 (☞ 334)	感应面 (☞ 334)	导线 (☞ 334)	LED U _B	LED ┌
BI15U-EM30WD-AP6X-H1141	1634820 ✕	S002	0.75	-40...+100	IP68 / IP69K	VA	LCP	-	-	•
BI15U-EM30-AP6X-H1141	1636733 ✕	S002	1	-30...+85	IP68	V2A	LCP	-	-	•
BI15U-EM30WD-AP6X-H1141/ 3GD	1634855 ✕	S002	0.75	-40...+100	IP68 / IP69K	VA	LCP	-	-	•
BI15U-M30-RP6X-H1141	1636739 ✕	S056	1	-30...+85	IP68	CuZn-Cr	LCP	-	-	•
BI15U-M30-AN6X-H1141	1636736 ✕	S005	1	-30...+85	IP68	CuZn-Cr	LCP	-	-	•
BI15U-MT30-AN6X-H1141	1636738	S005	1	-30...+85	IP68	CuZn-T	LCP	-	-	•
BI15U-EM30WD-AN6X-H1141	1634834	S005	0.75	-40...+100	IP68 / IP69K	VA	LCP	-	-	•
BI15U-EM30WD-AN6X-H1141/ 3GD	1634856	S005	0.75	-40...+100	IP68 / IP69K	VA	LCP	-	-	•
BI15U-M30-VN44X-H1141	1634889 ✕	S011	1	-30...+85	IP68	CuZn-Cr	LCP	-	-	•
BI15-M30-VN6X-H1141	4590719 ✕	S011	0.15	-25...+70	IP67	CuZn-Cr	PA	-	-	•
BI15-M30-AP6X-H1141	46185 ✕	S002	0.3	-25...+70	IP67	CuZn-Cr	PA	-	-	•
BI15-M30-AN6X-H1141	4618600	S005	0.3	-25...+70	IP67	CuZn-Cr	PA	-	-	•
BI12-M30-AD4X-H1141	4417041 ✕	S014	0.5	-25...+70	IP67	CuZn-Cr	PA	-	-	•
BI10U-M30-AP6X-H1141	1636140 ✕	S002	1	-30...+85	IP67	CuZn-Cr	PBT	-	-	•
BI10U-EM30-AP6X-H1141	1636340 ✕	S002	2	-30...+85	IP68	VA	PBT	-	-	•
BI10U-MT30-AP6X-H1141	1636240 ✕	S002	1	-30...+85	IP67	CuZn-T	PBT	-	-	•
BI10U-M30-VP4X-H1141	1582253 ✕	S008	1	-30...+85	IP67	CuZn-Cr	PBT	-	-	•
BI15-M30-VP6X-H1141	4590718 ✕	S008	0.15	-25...+70	IP67	CuZn-Cr	PA	-	-	•
BI10U-M30-AN6X-H1141	1636150 ✕	S005	1	-30...+85	IP67	CuZn-Cr	PBT	-	-	•
BI10U-EM30-AN6X-H1141	1636350 ✕	S005	2	-30...+85	IP68	VA	PBT	-	-	•
BI10U-MT30-AN6X-H1141	1636250	S005	1	-30...+85	IP67	CuZn-T	PBT	-	-	•
BI10U-M30-VN4X-H1141	1582352	S011	1	-30...+85	IP67	CuZn-Cr	PBT	-	-	•
BI10-M30-Y1X-H1141	40202 ✕	S026	0.5	-25...+70	IP67	CuZn-Cr	PA	-	-	•
BI10-EM30-Y1X-H1141	4020205 ✕	S026	0.5	-25...+70	IP67	VA	PA	-	-	•
BI10-M30-AP6X-H1141	46175 ✕	S002	0.5	-25...+70	IP67	CuZn-Cr	PA	-	-	•
BI10-M30-VP4X-H1141	15616 ✕	S008	2	-25...+70	IP67	CuZn-Cr	PA	-	-	•
BI10-M30-AN6X-H1141	46176 ✕	S005	0.5	-25...+70	IP67	CuZn-Cr	PA	-	-	•
BI10-M30-VN4X-H1141	15716	S011	2	-25...+70	IP67	CuZn-Cr	PA	-	-	•
BI10-M30-AD4X-H1141	44175 ✕	S014	0.5	-25...+70	IP67	CuZn-Cr	PA	-	-	•
BI10U-M30-AD4X-H1144	4405272 ✕	S99	0.02	-25...+70	IP68	CuZn-Cr	LCP	-	-	•
BI10U-MT30-AD4X-H1144	4405074 ✕	S99	0.01	-25...+70	IP68	CuZn-T	LCP-T	-	-	•

✕ = 优选型号











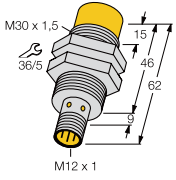



































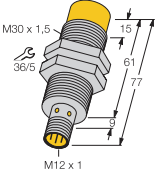

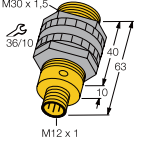

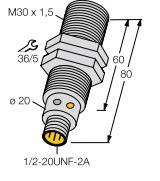

电感式传感器

尺寸/外形	特性	额定工作距离Sn [mm]	输出	工作电压	额定工作电流I _e [mA]
	M30 x 1,5 	<i>uprox</i> [®] 10, 	 , PNP	10...30 VDC	200 DC, 
		<i>uprox</i> [®] 10, 	 , NPN	10...30 VDC	200 DC, 
		<i>uprox</i> [®] 20, 	 , PNP	10...30 VDC	200 DC, 
		<i>uprox</i> [®] 20, 	 , NPN	10...30 VDC	200 DC, 
	M30 x 1,5 	-	 , PNP	10...30 VDC	200 DC, 
		-	 , NPN	10...30 VDC	200 DC, 
	M30 x 1,5 	harsh 选择型NF	 , PNP	10...30 VDC	200 DC, 
		harsh 选择型NF	 , NPN	10...30 VDC	200 DC, 
		<i>uprox</i> [®] +	 , NPN	10...30 VDC	200 DC, 
	M30 x 1,5 	<i>uprox</i> [®] +	 , PNP	10...30 VDC	200 DC, 
		PTFE <i>uprox</i> [®] +	 , PNP	10...30 VDC	200 DC, 
		 II 3 D 10 bar <i>uprox</i> [®] +	 , PNP	10...30 VDC	200 DC, 
		wash down <i>uprox</i> [®] +	 , PNP	10...55 VDC	200 DC, 
		10 bar <i>uprox</i> [®] +	 , PNP	10...55 VDC	200 DC, 
		wash down <i>uprox</i> [®] +	 , PNP	10...30 VDC	200 DC, 
		<i>uprox</i> [®] +	 , NPN	10...30 VDC	200 DC, 
		PTFE <i>uprox</i> [®] +	 , NPN	10...30 VDC	200 DC, 
		 II 3 D 10 bar <i>uprox</i> [®] +	 , NPN	10...30 VDC	200 DC, 
		wash down <i>uprox</i> [®] +	 , NPN	10...55 VDC	200 DC, 
		<i>uprox</i> [®]	 , PNP	10...30 VDC	200 DC, 
		<i>uprox</i> [®]	 , PNP	10...30 VDC	200 DC, 

型号	订货号	连接方式 (☞ 322)	开关频率 [kHz]	温度范围 [°C]	防护等级	外壳 (☞ 334)	感应面 (☞ 334)	导线 (☞ 334)	LED U _B	LED ┌
BI10U-S30-AP6X-H1141	1636600 ✕	S002	2	-30...+85	IP68	PBT	PA	-	-	•
BI10U-S30-AN6X-H1141	1636620	S005	2	-30...+85	IP68	PBT	PA	-	-	•
NI20U-S30-AP6X-H1141	1646600 ✕	S002	1.5	-30...+85	IP68	PBT	PA	-	-	•
NI20U-S30-AN6X-H1141	1646620	S005	1.5	-30...+85	IP68	PBT	PA	-	-	•
BI10-S30-AP6X-H1141	46580 ✕	S002	0.5	-25...+70	IP67	PA	PA	-	-	•
BI10-S30-AN6X-H1141	46581	S005	0.5	-25...+70	IP67	PA	PA	-	-	•
BI10NF-EM30HE-AP6X2-H1141	1615002 ✕	S002	2	0...+60	IP67	VA	DURO	-	•	•
BI10NF-EM30HE-AN6X2-H1141	1615005	S005	2	0...+60	IP67	VA	DURO	-	•	•
BI15U-M30E-AP6X-H1141	1636742	S002	1	-30...+85	IP68	CuZn-Cr	LCP	-	-	•
NI30U-M30-AP6X-H1141	1646631 ✕	S002	1	-30...+85	IP68	CuZn-Cr	LCP	-	-	•
NI30U-MT30-AP6X-H1141	1646633 ✕	S002	1	-30...+85	IP68	CuZn-T	LCP	-	-	•
NI30U-EM30WD-AP6X-H1141/3D	1634861 ✕	S002	0.5	-40...+100	IP68 / IP69K	VA	LCP	-	-	•
NI30U-M30-VP44X-H1141	1634887 ✕	S008	1	-30...+85	IP68	CuZn-Cr	LCP	-	-	•
NI30U-EM30WD-VP44X-H1141	1634904	S008	0.5	-30...+85	IP68 / IP69K	VA	LCP	-	-	•
NI30U-M30-RP6X-H1141	1646636 ✕	S056	1	-30...+85	IP68	CuZn-Cr	LCP	-	-	•
NI30U-M30-AN6X-H1141	1644635 ✕	S005	1	-30...+85	IP68	CuZn-Cr	LCP	-	-	•
NI30U-MT30-AN6X-H1141	1644637	S005	1	-30...+85	IP68	CuZn-T	LCP	-	-	•
NI30U-EM30WD-AN6X-H1141/3D	1634862	S005	0.5	-40...+100	IP68 / IP69K	VA	LCP	-	-	•
NI30U-M30-VN44X-H1141	1634891 ✕	S011	1	-30...+85	IP68	CuZn-Cr	LCP	-	-	•
NI20U-M30-AP6X-H1141	1646140 ✕	S002	1	-30...+85	IP67	CuZn-Cr	PBT	-	-	•
NI20U-EM30-AP6X-H1141	1646340 ✕	S002	1.5	-30...+85	IP68	VA	PBT	-	-	•

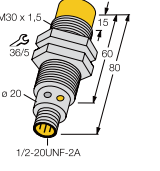
✕ = 优选型号

电感式传感器











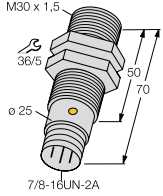





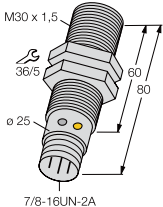



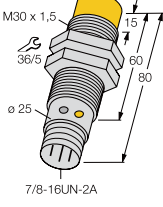



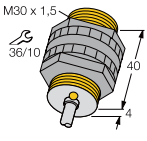



尺寸/外形	特性	额定工作距离Sn [mm]	输出	工作电压	额定工作电流I _e [mA]	
	M30 x 1,5 	PTFE <i>uprox</i> [®]	20, 	 , PNP	10...30 VDC	200 DC, (K)
		Sn +	20, 	 , PNP	10...30 VDC	200 DC, (K)
		<i>uprox</i> [®]	20, 	 , PNP	10...65 VDC	200 DC, (K)
		Sn +	20, 	 , PNP	10...30 VDC	200 DC, (K)
		<i>uprox</i> [®]	20, 	 , NPN	10...30 VDC	200 DC, (K)
		Sn +	20, 	 , NPN	10...30 VDC	200 DC, (K)
		PTFE <i>uprox</i> [®]	20, 	 , NPN	10...30 VDC	200 DC, (K)
		<i>uprox</i> [®] +	30, 	 , PNP	10...30 VDC	200 DC, (K)
		<i>uprox</i> [®]	20, 	 , NPN	10...30 VDC	200 DC, (K)
		<i>uprox</i> [®] +	30, 	 , NPN	10...30 VDC	200 DC, (K)
		<i>uprox</i> [®]	20, 	 , NPN	10...65 VDC	200 DC, (K)
		Sn +	20, 	 , NPN	10...30 VDC	200 DC, (K)
		-	20, 	 , 2-wire	10...65 VDC	100 DC, (K)
		Ex II 2 G SIL2	15, 	NAMUR	nom. 8.2 VDC	-
		Ex II 1 G Ex II 1 D SIL2	15, 	NAMUR	nom. 8.2 VDC	-
-	15, 	 , 2-wire	10...65 VDC	100 DC, (K)		
<i>uprox</i> [®] +	15, 	 , 2-wire	10...65 VDC	100 DC, (K)		
<i>uprox</i> [®] +	15, 	 , 2-wire	10...65 VDC	100 DC, (K)		
						
		<i>uprox</i> [®] +	30, 	 , PNP	10...30 VDC	200 DC, (K)
	M30 x 1,5 	-	15, 	 , PNP	10...30 VDC	200 DC, (K)
		-	15, 	 , NPN	10...30 VDC	200 DC, (K)
	M30 x 1,5 	<i>uprox</i> [®]	10, 		20...250 VAC 10...300 VDC	400 AC 300 DC, (K)
	M30 x 1,5 	<i>uprox</i> [®]	20, 		20...250 VAC 10...300 VDC	400 AC 300 DC, (K)

型号	订货号	连接方式 (☞ 322)	开关频率 [kHz]	温度范围 [°C]	防护等级	外壳 (☞ 334)	感应面 (☞ 334)	导线 (☞ 334)	LED U _B	LED ┘
NI20U-MT30-AP6X-H1141	1646240 ✘	S002	1	-30...+85	IP67	CuZn-T	PBT	-	-	•
NI20-M30-AP6X-H1141	4670510 ✘	S002	0.5	-25...+70	IP67	CuZn-Cr	PA	-	-	•
NI20U-M30-VP4X-H1141	1582457 ✘	S008	1	-30...+85	IP67	CuZn-Cr	PBT	-	-	•
NI20-M30-VP6X-H1141	4590612 ✘	S008	0.5	-25...+70	IP67	CuZn-Cr	PA	-	-	•
NI20U-M30-AN6X-H1141	1646150 ✘	S005	1	-30...+85	IP67	CuZn-Cr	PBT	-	-	•
NI20-M30-AN6X-H1141	4670515 ✘	S005	0.5	-25...+70	IP67	CuZn-Cr	PA	-	-	•
NI20U-MT30-AN6X-H1141	1646250	S005	1	-30...+85	IP67	CuZn-T	PBT	-	-	•
NI30U-EM30-AP6X-H1141	1646632 ✘	S002	1	-30...+85	IP68	V2A	LCP	-	-	•
NI20U-EM30-AN6X-H1141	1646350	S005	1.5	-30...+85	IP68	VA	PBT	-	-	•
NI30U-EM30-AN6X-H1141	1644636 ✘	S005	1	-30...+85	IP68	V2A	LCP	-	-	•
NI20U-M30-VN4X-H1141	1582552	S011	1	-30...+85	IP67	CuZn-Cr	LCP	-	-	•
NI20-M30-VN6X-H1141	4590614 ✘	S011	0.5	-25...+70	IP67	CuZn-Cr	PA	-	-	•
NI20-M30-AD4X-H1141	4466141 ✘	S014	0.2	-25...+70	IP67	CuZn-Cr	PA	-	-	•
NI15-M30-Y1X-H1141	40203 ✘	S026	0.2	-25...+70	IP67	CuZn-Cr	PBT	-	-	•
NI15-EM30-Y1X-H1141	1006260 ✘	S026	0.2	-25...+70	IP67	VA	PA	-	-	•
NI15-M30-AD4X-H1141	44177 ✘	S014	0.2	-25...+70	IP67	CuZn-Cr	PA	-	-	•
NI15U-M30-AD4X-H1144	4405075 ✘	S99	0.01	-25...+70	IP68	CuZn-Cr	LCP	-	-	•
NI15U-MT30-AD4X-H1144	4405077 ✘	S99	0.01	-25...+70	IP68	CuZn-T	LCP	-	-	•
NI30U-M30E-AP6X-H1141	1644756 ✘	S002	1	-30...+85	IP68	CuZn-Cr	LCP	-	-	•
NI15-S30-AP6X-H1141	46582 ✘	S002	0.5	-25...+70	IP67	PA	PA	-	-	•
NI15-S30-AN6X-H1141	46583	S005	0.5	-25...+70	IP67	PA	PA	-	-	•
BI10U-G30-ADZ30X2-B3131	4281613	S153	0.02	-30...+85	IP67	CuZn-Cr	PBT	-	•	•
NI20U-G30-ADZ30X2-B3131	4281813	S153	0.02	-30...+85	IP67	CuZn-Cr	PBT	-	•	•

✘ = 优选型号

2











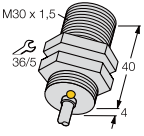







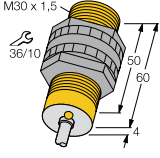









电感式传感器

尺寸/外形	特性	额定工作距离Sn [mm]	输出	工作电压	额定工作电流I _e [mA]		
	M30 x 1,5 	-	10, 	—, PNP	10...30 VDC	200 DC, 	
		-	10, 	—, NPN	10...30 VDC	200 DC, 	
	M30 x 1,5 	<i>uprox</i> [®]	10, 	—	20...250 VAC 10...300 VDC	400 AC 300 DC, 	
	M30 x 1,5 	<i>uprox</i> [®]	20, 	—	20...250 VAC 10...300 VDC	400 AC 300 DC, 	
	M30 x 1,5 	 II 2 G SIL2	10, 	NAMUR	nom. 8.2 VDC	-	
		 II 2 G SIL2 T -40 °C	10, 	NAMUR	nom. 8.2 VDC	-	
		 II 2 G SIL2 T +100 °C	10, 	NAMUR	nom. 8.2 VDC	-	
		 II 2 G SIL2	15, 	NAMUR	nom. 8.2 VDC	-	
		 II 2 G SIL2 T -40 °C	15, 	NAMUR	nom. 8.2 VDC	-	
		 II 2 G SIL2 T +100 °C	15, 	NAMUR	nom. 8.2 VDC	-	

型号	订货号	连接方式 (☞ 322)	开关频率 [kHz]	温度范围 [°C]	防护等级	外壳 (☞ 334)	感应面 (☞ 334)	导线 (☞ 334)	LED U _B	LED ┘
BI10-G30-AP6X-B1141	46965 ✕	S002	0.5	-25...+70	IP67	CuZn-Cr	PA	-	-	•
BI10-G30-AN6X-B1141	46954	S005	0.5	-25...+70	IP67	CuZn-Cr	PA	-	-	•
BI10U-G30-ADZ30X2-B1131	4281612	S153	0.02	-30...+85	IP67	CuZn-Cr	PBT	-	•	•
NI20U-G30-ADZ30X2-B1131	4281812	S153	0.02	-30...+85	IP67	CuZn-Cr	PBT	-	•	•
BI10-P30-Y1X	40400 ✕	S025	0.5	-25...+70	IP67	PA	PA	PVC 2 m	-	•
BI10-P30-Y1X/S97	1023322	S025	0.5	-40...+70	IP67	PA	PA	Silic. 2 m	-	•
BI10-P30-Y1/S100	10233 ✕	S025	0.5	-25...+100	IP67	PA	PA	PVC 2 m	-	-
NI15-P30-Y1X	40401 ✕	S025	0.2	-25...+70	IP67	PA	PA	PVC 2 m	-	•
NI15-P30-Y1X/S97	1022704	S025	0.2	-40...+70	IP67	PA	PA	Silic. 2 m	-	•
NI15-P30-Y1/S100	10227 ✕	S025	0.2	-25...+100	IP67	PA	PA	PVC 2 m	-	-

✕ = 优选型号

电感式传感器











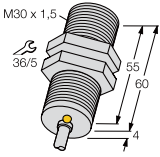































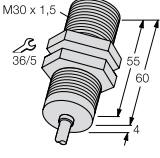



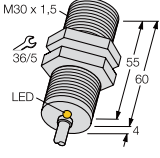

尺寸/外形	特性	额定工作距离Sn [mm]	输出	工作电压	额定工作电流I _e [mA]
	M30 x 1,5				
	—	12, 	—, 2-wire	10...65 VDC	100 DC, (K)
	 II 2 G SIL2	10, 	NAMUR	nom. 8.2 VDC	—
	 II 1 G  II 1 D SIL2 T +100 °C	10, 	NAMUR	nom. 8.2 VDC	—
	—	10, 	—, PNP	10...30 VDC	200 DC, (K)
	—	10, 	—, NPN	10...30 VDC	200 DC, (K)
	M30 x 1,5				
	<i>uprox</i> [®]	10, 	—, PNP	10...30 VDC	200 DC, (K)
	<i>uprox</i> [®]	10, 	—, NPN	10...30 VDC	200 DC, (K)
	—	10, 	—, PNP	10...30 VDC	200 DC, (K)
	T -40 °C	10, 	—, PNP	10...65 VDC	200 DC, (K)
	T +100 °C	10, 	—, PNP	10...65 VDC	200 DC, (K)
	—	10, 	—, NPN	10...30 VDC	200 DC, (K)
	—	10, 	—	20...250 VAC 10...300 VDC	400 AC 300 DC
	T -40 °C	10, 	—	20...250 VAC 10...300 VDC	400 AC 300 DC
	T +100 °C	10, 	—	20...250 VAC 10...300 VDC	400 AC 300 DC
	—	10, 	—, 2-wire	10...65 VDC	100 DC, (K)
	<i>uprox</i> [®]	20, 	—, PNP	10...30 VDC	200 DC, (K)
	<i>uprox</i> [®]	20, 	—, NPN	10...30 VDC	200 DC, (K)
	—	15, 	—, PNP	10...30 VDC	200 DC, (K)
	T -40 °C	15, 	—, PNP	10...65 VDC	200 DC, (K)
	T +100 °C	15, 	—, PNP	10...65 VDC	200 DC, (K)
	—	15, 	—, NPN	10...30 VDC	200 DC, (K)
	—	15, 	—	20...250 VAC 10...300 VDC	400 AC 300 DC
	T -40 °C	15, 	—	20...250 VAC 10...300 VDC	400 AC 300 DC
	T +100 °C	15, 	—	20...250 VAC 10...300 VDC	400 AC 300 DC
—	15, 	—, 2-wire	10...65 VDC	100 DC, (K)	

型号	订货号	连接方式 (☞ 322)	开关频率 [kHz]	温度范围 [°C]	防护等级	外壳 (☞ 334)	感应面 (☞ 334)	导线 (☞ 334)	LED U _B	LED ┌
BI12-G30K-AD4X	4417010 ✕	S013	0.5	-25...+70	IP67	CuZn-Cr	PA	PVC 2 m	-	•
BI10-G30-Y1X	40200 ✕	S025	0.5	-25...+70	IP67	CuZn-Cr	PA	PVC 2 m	-	•
BI10-EG30-Y1X/S100 7M	4012005 ✕	S025	0.5	-25...+100	IP67	VA	PA	PVC 7 m	-	•
BI10-G30K-AP6X	46706 ✕	S001	0.5	-25...+70	IP67	CuZn-Cr	PA	PVC 2 m	-	•
BI10-G30K-AN6X	46716	S004	0.5	-25...+70	IP67	CuZn-Cr	PA	PVC 2 m	-	•
BI10U-S30-AP6X	1636500 ✕	S001	2	-30...+85	IP68	PA	PA	PVC 2 m	-	•
BI10U-S30-AN6X	1636520	S004	2	-30...+85	IP68	PA	PA	PVC 2 m	-	•
BI10-S30-AP6X	46590 ✕	S001	0.5	-25...+70	IP67	PA	PA	PVC 2 m	-	•
BI10-S30-VP4X/S97	1512221	S007	0.5	-40...+70	IP67	PA	PA	Silic. 2 m	-	•
BI10-S30-VP4X/S100	15140 ✕	S007	0.5	-25...+100	IP67	PA	PA	PVC 2 m	-	•
BI10-S30-AN6X	46591 ✕	S004	0.5	-25...+70	IP67	PA	PA	PVC 2 m	-	•
BI10-S30-AZ3X	43554 ✕	S092	0.02	-25...+70	IP67	PA	PA	PVC 2 m	-	•
BI10-S30-AZ3X/S97	4355421	S092	0.02	-40...+70	IP67	PA	PA	Silic. 2 m	-	•
BI10-S30-AZ3X/S100	13719 ✕	S092	0.02	-25...+100	IP67	PA	PA	PVC 2 m	-	•
BI10-S30-AD4X	44590 ✕	S013	0.5	-25...+70	IP67	PA	PA	PVC 2 m	-	•
NI20U-S30-AP6X	1646500 ✕	S001	1.5	-30...+85	IP68	PA	PA	PVC 2 m	-	•
NI20U-S30-AN6X	1646520	S004	1.5	-30...+85	IP68	PA	PA	PVC 2 m	-	•
NI15-S30-AP6X	46592 ✕	S001	0.5	-25...+70	IP67	PA	PA	PVC 2 m	-	•
NI15-S30-VP4X/S97	1514110	S007	0.5	-40...+70	IP67	PA	PA	Silic. 2 m	-	•
NI15-S30-VP4X/S100	15141 ✕	S007	0.5	-25...+100	IP67	PA	PA	PVC 2 m	-	•
NI15-S30-AN6X	46593 ✕	S004	0.5	-25...+70	IP67	PA	PA	PVC 2 m	-	•
NI15-S30-AZ3X	43555 ✕	S092	0.02	-25...+70	IP67	PA	PA	PVC 2 m	-	•
NI15-S30-AZ3X/S97	1375803	S092	0.02	-40...+70	IP67	PA	PA	Silic. 2 m	-	•
NI15-S30-AZ3X/S100	13758 ✕	S092	0.02	-25...+100	IP67	PA	PA	PVC 2 m	-	•
NI15-S30-AD4X	44592 ✕	S013	0.2	-25...+70	IP67	PA	PA	PVC 2 m	-	•

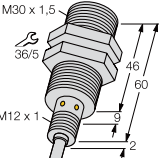
✕ = 优选型号

2











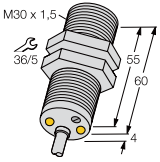





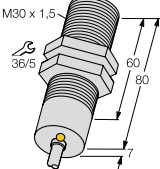





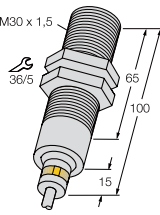





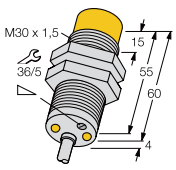



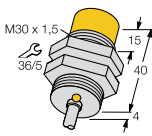

电感式传感器

尺寸/外形	特性	额定工作 距离Sn [mm]	输出	工作电压	额定工作 电流I _e [mA]		
	M30 x 1,5	<i>uprox</i> [®] +	15, 	—, PNP	10...30 VDC	200 DC, (K)	
		<i>uprox</i> [®] +	15, 	—, PNP	10...30 VDC	200 DC, (K)	
		Sn +	15, 	—, PNP	10...30 VDC	200 DC, (K)	
		<i>uprox</i> [®] +	15, 	 , PNP	10...55 VDC	200 DC, (K)	
		Sn +	15, 	 , PNP	10...30 VDC	200 DC, (K)	
		<i>uprox</i> [®] +	15, 	—, NPN	10...30 VDC	200 DC, (K)	
		Sn +	15, 	—, NPN	10...30 VDC	200 DC, (K)	
		<i>uprox</i> [®] +	15, 	 , NPN	10...55 VDC	200 DC, (K)	
		Sn +	15, 	 , NPN	10...30 VDC	200 DC, (K)	
		—	12, 	—, 2-wire	10...65 VDC	100 DC, (K)	
		<i>uprox</i> [®]	10, 	—, PNP	10...30 VDC	200 DC, (K)	
		<i>uprox</i> [®]	10, 	—, NPN	10...30 VDC	200 DC, (K)	
		<i>uprox</i> [®]	10, 	—	20...250 VAC 10...300 VDC	400 AC 300 DC, (K)	
		—	10, 	—, PNP	10...30 VDC	200 DC, (K)	
		—	10, 	 , PNP	10...65 VDC	200 DC, (K)	
		—	10, 	 , PNP	10...65 VDC	200 DC, (K)	
	—	10, 	—, NPN	10...30 VDC	200 DC, (K)		
	—	10, 	 , NPN	10...65 VDC	200 DC, (K)		
	—	10, 	 , NPN	10...65 VDC	200 DC, (K)		
	—	10, 	—	20...250 VAC 10...300 VDC	400 AC 300 DC		
	—	10, 	—, 2-wire	10...65 VDC	100 DC, (K)		
	<i>uprox</i> [®] +	10, 	—, 2-wire	10...65 VDC	100 DC, (K)		
	M30 x 1,5	<i>uprox</i> [®]	10, 	—, PNP	10...30 VDC	200 DC, (K)	
		<i>uprox</i> [®]	10, 	 , PNP	10...65 VDC	200 DC, (K)	
		<i>uprox</i> [®]	10, 	—, NPN	10...30 VDC	200 DC, (K)	
		<i>uprox</i> [®]	10, 	 , NPN	10...65 VDC	200 DC, (K)	
	M30 x 1,5	T +100 °C	10, 	—, PNP	10...30 VDC	200 DC, (K)	
	M30 x 1,5	10 bar <i>uprox</i> [®] +	wash down	15, 	—, PNP	10...30 VDC	200 DC, (K)
		10 bar <i>uprox</i> [®] +	wash down	15, 	 , PNP	10...55 VDC	200 DC, (K)
		10 bar <i>uprox</i> [®] +	wash down	15, 	—, NPN	10...30 VDC	200 DC, (K)

型号	订货号	连接方式 (☞ 322)	开关频率 [kHz]	温度范围 [°C]	防护等级	外壳 (☞ 334)	感应面 (☞ 334)	导线 (☞ 334)	LED U _B	LED ┌
BI15U-EM30-AP6X	1636741 ✕	S001	1	-30...+85	IP68	V2A	LCP	PVC 2 m	-	•
BI15U-M30-AP6X	1636731 ✕	S001	1	-30...+85	IP68	CuZn-Cr	LCP	PVC 2 m	-	•
BI15-M30-AP6X	4618530 ✕	S001	0.3	-25...+70	IP67	CuZn-Cr	PA	PVC 2 m	-	•
BI15U-M30-VP44X	1634884 ✕	S007	1	-30...+85	IP68	CuZn-Cr	LCP	PVC 2 m	-	•
BI15-M30-VP6X	4590716 ✕	S007	0.15	-25...+70	IP67	CuZn-Cr	PA	PVC 2 m	-	•
BI15U-M30-AN6X	1636735	S004	1	-30...+85	IP68	CuZn-Cr	LCP	PVC 2 m	-	•
BI15-M30-AN6X	4618620 ✕	S004	0.3	-25...+70	IP67	CuZn-Cr	PA	PVC 2 m	-	•
BI15U-M30-VN44X	1634888	S010	1	-30...+85	IP68	CuZn-Cr	LCP	PVC 2 m	-	•
BI15-M30-VN6X	4590717 ✕	S010	0.15	-25...+70	IP67	CuZn-Cr	PA	PVC 2 m	-	•
BI12-M30-AD4X	4417035 ✕	S013	0.5	-25...+70	IP67	CuZn-Cr	PA	PVC 2 m	-	•
BI10U-EM30-AP6X	1636300 ✕	S001	2	-30...+85	IP68	VA	LCP	PVC 2 m	-	•
BI10U-EM30-AN6X	1636320 ✕	S004	2	-30...+85	IP68	VA	LCP	PVC 2 m	-	•
BI10U-M30-ADZ30X2	4282610 ✕	S155	0.02	-30...+85	IP67	CuZn-Cr	PBT	PVC 2 m	•	•
BI10-M30-AP6X	46170 ✕	S001	0.5	-25...+70	IP67	CuZn-Cr	PA	PVC 2 m	-	•
BI10-M30-VP4X	15614 ✕	S007	0.5	-25...+70	IP67	CuZn-Cr	PA	PVC 2 m	-	•
BI10-EM30-VP4X 7M	1561134 ✕	S007	0.5	-25...+70	IP67	VA	PA	PVC 7 m	-	•
BI10-M30-AN6X	46171 ✕	S004	0.5	-25...+70	IP67	CuZn-Cr	PA	PVC 2 m	-	•
BI10-M30-VN4X	15714 ✕	S010	0.5	-25...+70	IP67	CuZn-Cr	PA	PVC 2 m	-	•
BI10-EM30-VN4X 7M	1561135	S010	0.5	-25...+70	IP67	VA	PA	PVC 7 m	-	•
BI10-M30-AZ3X	43164 ✕	S155	0.02	-25...+70	IP67	CuZn-Cr	PA	PVC 2 m	-	•
BI10-M30-AD4X	44170 ✕	S013	0.5	-25...+70	IP67	CuZn-Cr	PA	PVC 2 m	-	•
BI10U-M30-AD4X	4405073 ✕	S013	0.01	-25...+70	IP68	CuZn-Cr	LCP	PVC 2 m	-	•
BI10U-M30-AP6X	1636100 ✕	S001	1	-30...+85	IP67	CuZn-Cr	PBT	PVC 2 m	-	•
BI10U-M30-VP4X	1582201 ✕	S007	1	-30...+85	IP67	CuZn-Cr	PBT	PVC 2 m	-	•
BI10U-M30-AN6X	1636120 ✕	S004	1	-30...+85	IP67	CuZn-Cr	PBT	PVC 2 m	-	•
BI10U-M30-VN4X	1582303	S010	1	-30...+85	IP67	CuZn-Cr	PBT	PVC 2 m	-	•
BI10-M30-AP6X/S100	4617004 ✕	S001	0.5	-25...+100	IP67	CuZn-Cr	PA-X	PVC 2 m	-	•
BI15U-EM30WD-AP6X	1634819 ✕	S001	0.75	-40...+100	IP68 / IP69K	V4A	LCP	PP 2M	-	•
BI15U-EM30WD-VP44X/S90 20M	1634895 ✕	S007	0.75	-30...+85	IP68 / IP69K	V4A	LCP	PUR 20M	-	•
BI15U-EM30WD-AN6X	1634843	S004	0.75	-40...+100	IP68 / IP69K	VA	LCP	PVC 2 m	-	•

✕ = 优选型号











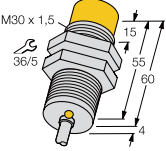





















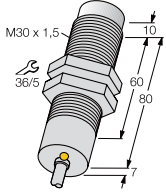

电感式传感器

尺寸/外形	特性	额定工作距离Sn [mm]	输出	工作电压	额定工作电流I _e [mA]
	M30 x 1,5 转速监控	10, 	 , PNP	10...65 VDC	200 DC, 
	M30 x 1,5 转速监控	10, 	 , PNP	10...65 VDC	200 DC, 
	M30 x 1,5 -	10, 	 , PNP	10...30 VDC	200 DC, 
	M30 x 1,5 -	10, 		20...250 VAC	400 AC
	M30 x 1,5 10 bar T +160 °C T +120 °C wash down	10, 	 , PNP	10...30 VDC	200 DC, 
	M30 x 1,5 -	10, 	 , PNP	10...30 VDC	200 DC, 
	M30 x 1,5 转速监控	20, 	 , PNP	10...65 VDC	200 DC, 
	M30 x 1,5 转速监控	20, 	 , PNP	10...65 VDC	200 DC, 
	M30 x 1,5 -	20, 	 , 2-wire	10...65 VDC	100 DC, 
	M30 x 1,5 Ex II 2 G SIL2	15, 	NAMUR	nom. 8.2 VDC	-
	M30 x 1,5 -	15, 	 , NPN	10...30 VDC	200 DC, 
	M30 x 1,5 Ex II 1 G	15, 	NAMUR	nom. 8.2 VDC	-
	M30 x 1,5 Ex II 1 D SIL2, T +100 °C	15, 	NAMUR	nom. 8.2 VDC	-

型号	订货号	连接方式 (☞ 322)	开关频率 [kHz]	温度范围 [°C]	防护等级	外壳 (☞ 334)	感应面 (☞ 334)	导线 (☞ 334)	LED U _B	LED ┌
DBI10U-M30-AP4X2	1582231 ✕	S059	-	-30...+85	IP67	CuZn-Cr	PBT	PVC 2 m	•	•
DTBI10U-M30-AP4X2	1582230 ✕	S059	-	-30...+85	IP67	CuZn-Cr	PBT	PVC 2 m	•	•
BI10-M30-AP6X/S120	4617010 ✕	S001	0.1	-25...+120	IP67	CuZn-Cr	PA	Silic. 2 m	-	•
BI10-M30-AZ3X/S120	4316410 ✕	S092	0.02	-25...+120	IP67	CuZn-Cr	PA	Silic. 2 m	-	•
BI10-EM30-AP6/S907	4614513 ✕	S001	0.2	-25...+160	IP68 / IP69K	VA	PEEK	PTFE 2 m	-	-
BI10-EM30D-VP6X/S120	4617035 ✕	S007	0.1	-25...+120	IP68 / IP69K	VA	PTFE	PTFE 2 m	-	•
DNI20U-M30-AP4X2	1582233 ✕	S059	-	-30...+85	IP67	CuZn-Cr	PBT	PVC 2 m	•	•
DTNI20U-M30-AP4X2	1582232 ✕	S059	-	-30...+85	IP67	CuZn-Cr	PBT	PVC 2 m	•	•
NI20-G30K-AD4X	4417220	S013	0.2	-25...+70	IP67	CuZn-Cr	PA	PVC 2 m	-	•
NI15-G30-Y1X	40201 ✕	S025	0.2	-25...+70	IP67	CuZn-Cr	PA	PVC 2 m	-	•
NI15-G30K-AN6X	46717	S004	0.5	-25...+70	IP67	CuZn-Cr	PA	PVC 2 m	-	•
NI15-EG30-Y1X/S100 7M	4012004 ✕	S025	0.2	-25...+100	IP67	VA	PA	PVC 7 m	-	•

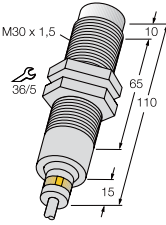
✕ = 优选型号











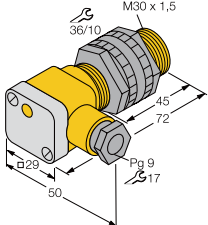



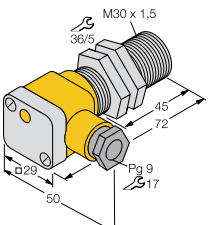



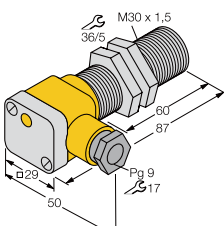





























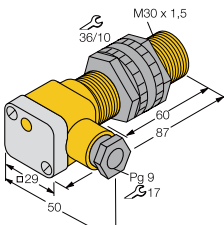













电感式传感器

尺寸/外形	特性	额定工作距离 Sn [mm]	输出	工作电压	额定工作 电流 I _e [mA]	
	M30 x 1,5 	<i>uprox</i> [®] +	30, 	—, PNP	10...30 VDC	200 DC, (K)
		<i>uprox</i> [®] +	30, 	—, PNP	10...30 VDC	200 DC, (K)
		<i>uprox</i> [®] +	30, 	—, PNP	10...55 VDC	200 DC, (K)
		<i>uprox</i> [®] +	30, 	—, NPN	10...30 VDC	200 DC, (K)
		<i>uprox</i> [®] +	30, 	—, NPN	10...55 VDC	200 DC, (K)
		<i>uprox</i> [®]	20, 	—, PNP	10...30 VDC	200 DC, (K)
		<i>uprox</i> [®]	20, 	—, PNP	10...30 VDC	200 DC, (K)
		<i>uprox</i> [®]	20, 	—, PNP	10...65 VDC	200 DC, (K)
		Sn +	20, 	—, PNP	10...30 VDC	200 DC, (K)
		<i>uprox</i> [®]	20, 	—, PNP	10...65 VDC	200 DC, (K)
		<i>uprox</i> [®]	20, 	—, NPN	10...30 VDC	200 DC, (K)
		<i>uprox</i> [®]	20, 	—, NPN	10...30 VDC	200 DC, (K)
		<i>uprox</i> [®]	20, 	—, NPN	10...65 VDC	200 DC, (K)
		Sn +	20, 	—, NPN	10...30 VDC	200 DC, (K)
		<i>uprox</i> [®]	20, 	—, NPN	20...250 VAC 10...300 VDC	400 AC 300 DC, (K)
		-	20, 	—, 2-wire	10...65 VDC	100 DC, (K)
		-	15, 	—, PNP	10...30 VDC	200 DC, (K)
		T +100 °C	15, 	—, PNP	10...30 VDC	200 DC, (K)
		-	15, 	—, PNP	10...65 VDC	200 DC, (K)
		-	15, 	—, PNP	10...65 VDC	200 DC, (K)
-	15, 	—, NPN	10...30 VDC	200 DC, (K)		
-	15, 	—, NPN	10...65 VDC	200 DC, (K)		
-	15, 	—, NPN	10...65 VDC	200 DC, (K)		
-	15, 	—, NPN	20...250 VAC 10...300 VDC	400 AC 300 DC		
-	15, 	—, 2-wire	10...65 VDC	100 DC, (K)		
	M30 x 1,5 	T +120 °C	15, 	—, PNP	10...30 VDC	200 DC, (K)
		T +120 °C	15, 	—	20...250 VAC	400 AC
	M30 x 1,5 	T +160 °C	15, 	—, PNP	10...30 VDC	200 DC, (K)
		T +120 °C wash down	15, 	—, PNP	10...30 VDC	200 DC, (K)

型号	订货号	连接方式 (☞ 322)	开关频率 [kHz]	温度范围 [°C]	防护等级	外壳 (☞ 334)	感应面 (☞ 334)	导线 (☞ 334)	LED U _B	LED ┘
NI30U-M30-AP6X	1646630 ✘	S001	1	-30...+85	IP68	CuZn-Cr	LCP	PVC 2 m	-	•
NI30U-M30-RP6X	1646634 ✘	S054	1	-30...+85	IP68	CuZn-Cr	LCP	PVC 2 m	-	•
NI30U-M30-VP44X	1634886 ✘	S007	1	-30...+85	IP68	CuZn-Cr	LCP	PVC 2 m	-	•
NI30U-M30-AN6X	1644634	S004	1	-30...+85	IP68	CuZn-Cr	LCP	PVC 2 m	-	•
NI30U-M30-VN44X	1634890	S010	1	-30...+85	IP68	CuZn-Cr	LCP	PVC 2 m	-	•
NI20U-M30-AP6X	1646100 ✘	S001	1	-30...+85	IP67	CuZn-Cr	PBT	PVC 2 m	-	•
NI20U-EM30-AP6X	1646300 ✘	S001	1.5	-30...+85	IP68	VA	PBT	PVC 2 m	-	•
NI20U-M30-VP4X	1582401 ✘	S007	1	-30...+85	IP67	CuZn-Cr	PBT	PVC 2 m	-	•
NI20-M30-VP6X 7M	4590611 ✘	S007	0.5	-25...+70	IP67	CuZn-Cr	PA	PVC 7 m	-	•
NI20U-EM30-VP4X	1582462	S007	1.5	-30...+85	IP68	VA	PBT	PVC 2 m	-	•
NI20U-M30-AN6X	1646120 ✘	S004	1	-30...+85	IP67	CuZn-Cr	PBT	PVC 2 m	-	•
NI20U-EM30-AN6X	1646320	S004	1.5	-30...+85	IP68	VA	PBT	PVC 2 m	-	•
NI20U-M30-VN4X	1582501	S010	1	-30...+85	IP67	CuZn-Cr	PBT	PVC 2 m	-	•
NI20-M30-VN6X 7M	4590613	S010	0.5	-25...+70	IP67	CuZn-Cr	PA	PVC 7 m	-	•
NI20U-M30-ADZ30X2	4282810 ✘	S155	0.02	-30...+85	IP67	CuZn-Cr	PBT	PVC 2 m	•	•
NI20-M30-AD4X	4466135 ✘	S013	0.2	-25...+70	IP67	CuZn-Cr	PA	PVC 2 m	-	•
NI15-M30-AP6X	46172 ✘	S001	0.5	-25...+70	IP67	CuZn-Cr	PA	PVC 2 m	-	•
NI15-M30-AP6X/S100	4617200 ✘	S001	0.5	-25...+100	IP67	CuZn-Cr	PA-X	PVC 2 m	-	•
NI15-M30-VP4X	15615 ✘	S007	0.5	-25...+70	IP67	CuZn-Cr	PA	PVC 2 m	-	•
NI15-EM30-VP4X 7M	1561137 ✘	S007	0.5	-25...+70	IP67	VA	PA	PVC 7 m	-	•
NI15-M30-AN6X	46173 ✘	S004	0.5	-25...+70	IP67	CuZn-Cr	PA	PVC 2 m	-	•
NI15-M30-VN4X	15715 ✘	S010	0.5	-25...+70	IP67	CuZn-Cr	PA	PVC 2 m	-	•
NI15-EM30-VN4X 7M	1561136	S010	0.5	-25...+70	IP67	VA	PA	PVC 7 m	-	•
NI15-M30-AZ3X	43165 ✘	S155	0.02	-25...+70	IP67	CuZn-Cr	PA	PVC 2 m	-	•
NI15-M30-AD4X	44172 ✘	S013	0.2	-25...+70	IP67	CuZn-Cr	PA	PVC 2 m	-	•
NI15-M30-AP6X/S120	4617210 ✘	S001	0.5	-25...+120	IP67	CuZn-Cr	PA	Silic. 2 m	-	•
NI15-M30-AZ3X/S120	4316506 ✘	S092	0.02	-25...+120	IP67	CuZn-Cr	PA	Silic. 2 m	-	•
NI15-EM30-AP6/S907	4617412 ✘	S001	0.2	-25...+160	IP68 / IP69K	VA	PEEK	PTFE 2 m	-	-
NI15-EM30D-VP6X/S120	4617410 ✘	S007	0.1	-25...+120	IP68 / IP69K	VA	PTFE	PTFE 2 m	-	•

✘ = 优选型号

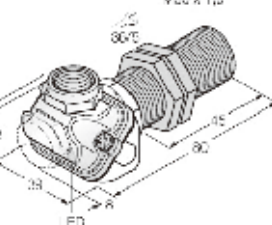
电感式传感器











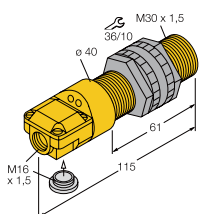



















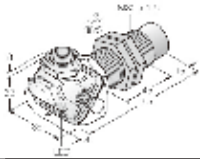

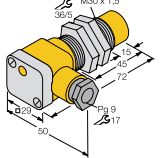





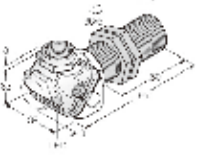



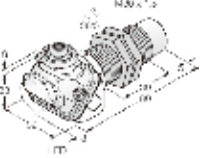

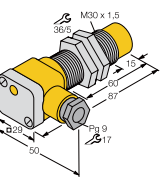

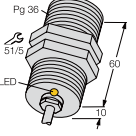

尺寸/外形	特性	额定工作距离Sn [mm]	输出	工作电压	额定工作电流Ie [mA]	
	M30 x 1,5	Ex II 2 G SIL2 	10, 	NAMUR	nom. 8.2 VDC	-
		Ex II 2 G SIL2 	15, 	NAMUR	nom. 8.2 VDC	-
	M30 x 1,5	Ex II 1 G Ex II 1 D SIL2 	10, 	NAMUR	nom. 8.2 VDC	-
		Ex II 2 G SIL2 	10, 	NAMUR	nom. 8.2 VDC	-
	M30 x 1,5	<i>uproX</i> [®]	10, 	 , PNP	10...30 VDC	200 DC, 
		<i>uproX</i> [®]	10, 	 , PNP	10...65 VDC	200 DC, 
		<i>uproX</i> [®]	10, 	 , NPN	10...30 VDC	200 DC, 
		<i>uproX</i> [®]	10, 	 , NPN	10...65 VDC	200 DC, 
		-	10, 	 , PNP	10...30 VDC	200 DC, 
		-	10, 	 , NPN	10...30 VDC	200 DC, 
		<i>uproX</i> [®]	20, 	 , PNP	10...65 VDC	200 DC, 
		<i>uproX</i> [®]	20, 	 , PNP	10...30 VDC	200 DC, 
		<i>uproX</i> [®]	20, 	 , NPN	10...30 VDC	200 DC, 
		<i>uproX</i> [®]	20, 	 , NPN	10...65 VDC	200 DC, 
	M30 x 1,5	<i>uproX</i> [®]	10, 	 , PNP	10...30 VDC	200 DC, 
		<i>uproX</i> [®]	10, 	 , NPN	10...30 VDC	200 DC, 
		-	10, 	 , PNP	10...30 VDC	200 DC, 
		<i>uproX</i> [®]	20, 	 , PNP	10...30 VDC	200 DC, 
		<i>uproX</i> [®]	20, 	 , NPN	10...30 VDC	200 DC, 
		-	15, 	 , PNP	10...30 VDC	200 DC, 
		-	15, 	 , NPN	10...30 VDC	200 DC, 
	M30 x 1,5	T+100°C	10, 	NAMUR	nom. 8.2 VDC	

型号	订货号	连接方式 (☞ 322)	开关频率 [kHz]	温度范围 [°C]	防护等级	外壳 (☞ 334)	感应面 (☞ 334)	导线 (☞ 334)	LED	LED
									U _B	⏏
BI10-P30SK-Y1X	40410 ✘	S027	0.5	-25...+70	IP67	PA	PA	-	-	•
NI15-P30SK-Y1X	40411 ✘	S027	0.2	-25...+70	IP67	PA	PA	-	-	•
BI10-EG30SK-Y1X	4012070 ✘	S027	0.5	-25...+70	IP67	VA	PA	-	-	•
BI10-G30SK-Y1X	40220 ✘	S027	0.5	-25...+70	IP67	CuZn-Cr	PA	-	-	•
BI10U-EG30SK-AP6X	1636400 ✘	S003	2	-30...+85	IP68	VA	LCP	-	-	•
BI10U-EG30SK-VP4X	1582601 ✘	S009	2	-30...+85	IP68	VA	LCP	-	-	•
BI10U-EG30SK-AN6X	1636420	S006	2	-30...+85	IP68	VA	LCP	-	-	•
BI10U-EG30SK-VN4X	1582701	S012	2	-30...+85	IP68	VA	LCP	-	-	•
BI10-G30SK-AP6X	46480 ✘	S003	0.5	-25...+70	IP67	CuZn-Cr	PA	-	-	•
BI10-G30SK-AN6X	46481	S006	0.5	-25...+70	IP67	CuZn-Cr	PA	-	-	•
NI20U-EG30SK-VP4X	1582801 ✘	S009	1.5	-30...+85	IP68	VA	PBT	-	-	•
NI20U-EG30SK-AP6X	1646400 ✘	S003	1.5	-30...+85	IP68	VA	PBT	-	-	•
NI20U-EG30SK-AN6X	1646420	S006	1.5	-30...+85	IP68	VA	PBT	-	-	•
NI20U-EG30SK-VN4X	1582901	S012	1.5	-30...+85	IP68	VA	PBT	-	-	•
BI10U-P30SK-AP6X	1636700 ✘	S003	2	-30...+85	IP68	PA	PA	-	-	•
BI10U-P30SK-AN6X	1636720	S006	2	-30...+85	IP68	PA	PA	-	-	•
BI10-P30SK-AP6X	46595 ✘	S003	0.5	-25...+70	IP67	PA	PA	-	-	•
NI20U-P30SK-AP6X	1646700 ✘	S003	1.5	-30...+85	IP68	PA	PA	-	-	•
NI20U-P30SK-AN6X	1646720	S006	1.5	-30...+85	IP68	PA	PA	-	-	•
NI15-P30SK-AP6X	46597 ✘	S003	0.5	-25...+70	IP67	PA	PA	-	-	•
NI15-P30SK-AN6X	46598	S006	0.5	-25...+70	IP67	PA	PA	-	-	•
BI10-EM30WDTC-Y1X	4012071 ✘	S027	0.5	-40...+100	IP68/IP69K	V4A	LCP	-	-	•

✘ = 优选型号













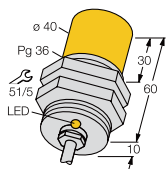







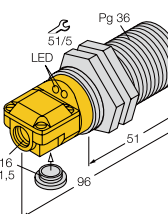







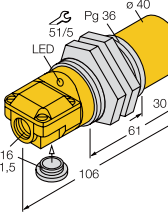







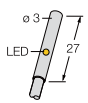





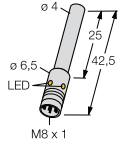

电感式传感器

尺寸/外形	特性	额定工作距离Sn [mm]	输出	工作电压	额定工作电流I _e [mA]	
	M30 x 1,5 	-	10, 	 , PNP	10...30 VDC	200 DC, (K)
		-	10, 	 , PNP	10...65 VDC	200 DC, (K)
		-	10, 	 , NPN	10...30 VDC	200 DC, (K)
		-	10, 	 , NPN	10...65 VDC	200 DC, (K)
		-	10, 	program.	20...250 VAC 10...300 VDC	400 AC 300 DC
		-	15, 	 , PNP	10...30 VDC	200 DC, (K)
		-	15, 	 , PNP	10...65 VDC	200 DC, (K)
		-	15, 	 , NPN	10...30 VDC	200 DC, (K)
		-	15, 	 , NPN	10...65 VDC	200 DC, (K)
		-	15, 	program.	20...250 VAC 10...300 VDC	400 AC 300 DC
	Food	30, 	 , PNP	10...30 VDC	200 DC, (K)	
	M30 x 1,5 		15, 	NAMUR	nom. 8.2 VDC	-
			15, 	NAMUR	nom. 8.2 VDC	-
	M30 x 1,5 	uprox®+ Food 10 bar	15, 	 , PNP	10...30 VDC	200 DC, (K)
	T +100 °C	15, 	NAMUR	nom. 8.2 VDC		
	M30 x 1,5 	-	15, 	 , PNP	10...30 VDC	200 DC, (K)
		-	15, 	 , NPN	10...30 VDC	200 DC, (K)
	G47 		20, 	NAMUR	nom. 8.2 VDC	-
		-	20, 	 , PNP	10...65 VDC	200 DC, (K)
		-	20, 	 , NPN	10...65 VDC	200 DC, (K)
		-	20, 		20...250 VAC 10...300 VDC	400 AC 300 DC

型号	订货号	连接方式 (☞ 322)	开关频率 [kHz]	温度范围 [°C]	防护等级	外壳 (☞ 334)	感应面 (☞ 334)	导线 (☞ 334)	LED U _B	LED ┘
BI10-P30SR-AP6X	16116 ✕	S003	0.5	-25...+70	IP67	ABS	ABS	-	-	•
BI10-P30SR-VP4X2	15652 ✕	S009	0.5	-25...+70	IP67	ABS	ABS	-	•	•
BI10-P30SR-AN6X	16203 ✕	S006	0.5	-25...+70	IP67	ABS	ABS	-	-	•
BI10-P30SR-VN4X2	15752 ✕	S012	0.5	-25...+70	IP67	ABS	ABS	-	•	•
BI10-P30SR-FZ3X2	13420 ✕	S016	0.02	-25...+70	IP67	ABS	ABS	-	•	•
NI15-P30SR-AP6X	16117 ✕	S003	0.5	-25...+70	IP67	ABS	ABS	-	-	•
NI15-P30SR-VP4X2	15653 ✕	S009	0.5	-25...+70	IP67	ABS	ABS	-	•	•
NI15-P30SR-AN6X	16204	S006	0.5	-25...+70	IP67	ABS	ABS	-	-	•
NI15-P30SR-VN4X2	15753 ✕	S012	0.5	-25...+70	IP67	ABS	ABS	-	•	•
NI15-P30SR-FZ3X2	13421 ✕	S016	0.02	-25...+70	IP67	ABS	ABS	-	•	•
NI30U-EM30WDTC-AP6X	1634765 ✕	S003	0.5	-40...+100	IP68/IP69K	V4A	LCP	-	-	•
NI15-G30SK-Y1X	40221 ✕	S027	0.2	-25...+70	IP67	CuZn-Cr	PA	-	-	•
NI15-EG30SK-Y1X	4012160 ✕	S027	0.2	-25...+70	IP67	VA	PA	-	-	•
BI15U-EM30WDTC-AP6X	1634764	S003	0.75	-40...+100	IP68/IP69K	V4A	LCP	-	-	•
NI15-EM30WDTC-Y1X	4012161	S027	0.2	-40...+100	IP68/IP69K	V4A	LCP	-	-	•
NI15-G30SK-AP6X	46482 ✕	S003	0.5	-25...+70	IP67	CuZn-Cr	PA	-	-	•
NI15-G30SK-AN6X	46483	S006	0.5	-25...+70	IP67	CuZn-Cr	PA	-	-	•
BI20-G47-Y1X	10202 ✕	S025	0.2	-25...+70	IP67	CuZn-Cr	PA	PVC 2 m	-	•
BI20-G47-AP4X	15645 ✕	S001	0.1	-25...+70	IP67	CuZn-Cr	PA	PVC 2 m	-	•
BI20-G47-AN4X	15745 ✕	S004	0.1	-25...+70	IP67	CuZn-Cr	PA	PVC 2 m	-	•
BI20-G47-AZ3X	13088 ✕	S155	0.02	-25...+70	IP67	CuZn-Cr	PA	PVC 2 m	-	•

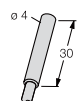
✕ = 优选型号











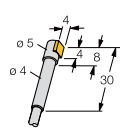

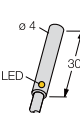







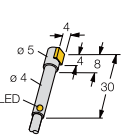







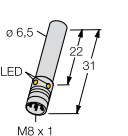











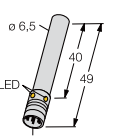





电感式传感器

尺寸/外形	特性	额定工作距离Sn [mm]	输出	工作电压	额定工作电流I _e [mA]	
	G47	-	-	-	-	
		-	25, 	 , PNP	10...65 VDC	200 DC, 
	-	25, 	 , NPN	10...65 VDC	200 DC, 	
	G47	-	-	-	-	
		-	25, 	 , PNP	10...65 VDC	200 DC, 
	-	25, 	 , NPN	10...65 VDC	200 DC, 	
	G47	-	-	-	-	
		-	40, 	 , PNP	10...65 VDC	200 DC, 
	-	40, 	 , NPN	10...65 VDC	200 DC, 	
	Ø3	-	-	-	-	
		-	1, 	 , PNP	10...30 VDC	100 DC
	-	1, 	 , NPN	10...30 VDC	100 DC	
	Ø4	-	-	-	-	
		-	1, 	 , PNP	10...30 VDC	100 DC, 
	-	1, 	 , NPN	10...30 VDC	100 DC, 	
	Ø4	-	-	-	-	
		 II 2 G SIL2	1, 	NAMUR	nom. 8.2 VDC	-

型号	订货号	连接方式 (☞ 322)	开关频率 [kHz]	温度范围 [°C]	防护等级	外壳 (☞ 334)	感应面 (☞ 334)	导线 (☞ 334)	LED U _B	LED ┘
NI25-G47-AP4X	15646 x	S001	0.1	-25...+70	IP67	CuZn-Cr	PA	PVC 2 m	-	•
NI25-G47-AN4X	15746 x	S004	0.1	-25...+70	IP67	CuZn-Cr	PA	PVC 2 m	-	•
NI25-G47-AZ3X	13089 x	S155	0.02	-25...+70	IP67	CuZn-Cr	PA	PVC 2 m	-	•
BI25-G47SR-VP4X2	15648 x	S009	0.1	-25...+70	IP67	CuZn-Cr	PA	-	•	•
BI25-G47SR-VN4X2	15748 x	S012	0.1	-25...+70	IP67	CuZn-Cr	PA	-	•	•
BI25-G47SR-FZ3X2	13427 x	S016	0.02	-25...+70	IP67	CuZn-Cr	PA	-	•	•
NI40-G47SR-VP4X2	15650 x	S009	0.1	-25...+70	IP67	CuZn-Cr	PA	-	•	•
NI40-G47SR-VN4X2	15750	S012	0.1	-25...+70	IP67	CuZn-Cr	PA	-	•	•
NI40-G47SR-FZ3X2	13428 x	S016	0.02	-25...+70	IP67	CuZn-Cr	PA	-	•	•
BI1-EH03-AP7X	1619322 x	S001	2	-25...+70	IP67	VA	POM	PUR 2 m	-	•
BI1-EH03-AN7X	1619323 x	S004	5	-25...+70	IP67	VA	POM	PUR 2 m	-	•
BI1-EH04-AP6X-V1331	4608440 x	S002	3	-25...+70	IP67	VA	PA	-	-	•
BI1-EH04-RP6X-V1331	4608441	S175	3	-25...+70	IP67	VA	PA	-	-	•
BI1-EH04-AN6X-V1331	4608540 x	S005	3	-25...+70	IP67	VA	PA	-	-	•
BI1-EH04-Y1	1003040 x	S025	5	-25...+70	IP67	VA	PA	PVC 2 m	-	-

x = 优选型号











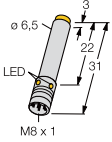





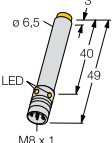











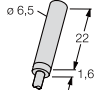

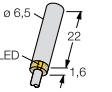











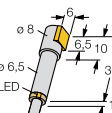





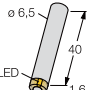

电感式传感器

尺寸/外形	特性	额定工作距离Sn [mm]	输出	工作电压	额定工作电流I _e [mA]	
	Ø4 	Ex II 2 G SIL2	1, 	NAMUR	nom. 8.2 VDC	-
	Ø4 	-	1, 	 , PNP	10...30 VDC	100 DC, (K)
		-	1, 	 , PNP	10...30 VDC	100 DC, (K)
		-	1, 	 , NPN	10...30 VDC	100 DC, (K)
	Ø4 	-	1, 	 , PNP	10...30 VDC	100 DC, (K)
		-	1, 	 , PNP	10...30 VDC	100 DC, (K)
		-	1, 	 , NPN	10...30 VDC	100 DC, (K)
	Ø6,5 	Sn +	2, 	 , PNP	10...30 VDC	150 DC, (K)
		Sn +	2, 	 , PNP	10...30 VDC	150 DC, (K)
		Sn +	2, 	 , NPN	10...30 VDC	150 DC, (K)
		-	1.5, 	 , PNP	10...30 VDC	150 DC, (K)
		-	1.5, 	 , NPN	10...30 VDC	150 DC, (K)
	Ø6,5 	uprox®+	2, 	 , PNP	10...30 VDC	150 DC, (K)
		uprox®+	2, 	 , PNP	10...30 VDC	150 DC, (K)
		uprox®+	2, 	 , NPN	10...30 VDC	150 DC, (K)
		Sn +	2, 	 , PNP	10...30 VDC	150 DC, (K)
		Sn +	2, 	 , NPN	10...30 VDC	150 DC, (K)
		-	1.5, 	 , PNP	10...30 VDC	150 DC, (K)
		-	1.5, 	 , NPN	10...30 VDC	150 DC, (K)

型号	订货号	连接方式 (☞ 322)	开关频率 [kHz]	温度范围 [°C]	防护等级	外壳 (☞ 334)	感应面 (☞ 334)	导线 (☞ 334)	LED U _B	LED ┘
BI1-HS540-Y1	1004001 ✕	S025	5	-25...+70	IP67	VA	PA	PVC 2 m	-	-
BI1-EH04-AP6X	4609540 ✕	S001	3	-25...+70	IP67	VA	PA	PUR 2 m	-	•
BI1-EH04-RP6X	4608442	S054	3	-25...+70	IP67	VA	PA	PUR 2 m	-	•
BI1-EH04-AN6X	4609640 ✕	S004	3	-25...+70	IP67	VA	PA	PUR 2 m	-	•
BI1-HS540-AP6X	4604001 ✕	S001	3	-25...+70	IP67	VA	PA	PUR 2 m	-	•
BI1-HS540-RP6X	4604050	S054	3	-25...+70	IP67	VA	PA	PUR 2 m	-	•
BI1-HS540-AN6X	4604101 ✕	S004	3	-25...+70	IP67	VA	PA	PUR 2 m	-	•
BI2-EH6,5K-AP6X-V1131	4610020 ✕	S002	3	-25...+70	IP67	VA	PA	-	-	•
BI2-EH6,5K-RP6X-V1131	4610021	S175	3	-25...+70	IP67	VA	PA	-	-	•
BI2-EH6,5K-AN6X-V1131	4610120	S005	3	-25...+70	IP67	VA	PA	-	-	•
BI1,5-EH6,5K-AP6X-V1131	4610740 ✕	S002	3	-25...+70	IP67	VA	PA	-	-	•
BI1,5-EH6,5K-AN6X-V1131	4610840	S005	3	-25...+70	IP67	VA	PA	-	-	•
BI2U-EH6,5-AP6X-V1131	4281160 ✕	S002	2	-30...+85	IP68	VA	PA	-	-	•
BI2U-EH6,5-RP6X-V1131	1637151	S175	2	-30...+85	IP68	VA	PA	-	-	•
BI2U-EH6,5-AN6X-V1131	4281180	S005	2	-30...+85	IP68	VA	PA	-	-	•
BI2-EH6,5-AP6X-V1131	4612220 ✕	S002	3	-25...+70	IP67	VA	PA	-	-	•
BI2-EH6,5-AN6X-V1131	4612320	S005	3	-25...+70	IP67	VA	PA	-	-	•
BI1,5-EH6,5-AP6X-V1131	4612020 ✕	S002	3	-25...+70	IP67	VA	PA	-	-	•
BI1,5-EH6,5-AN6X-V1131	4612120	S005	3	-25...+70	IP67	VA	PA	-	-	•

✕ = 优选型号

电感式传感器











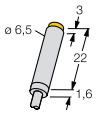





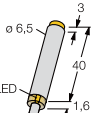













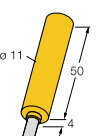









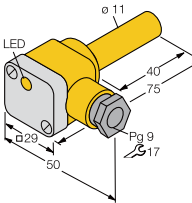

尺寸/外形	特性	额定工作距离Sn [mm]	输出	工作电压	额定工作电流I _e [mA]	
		3, 	 , PNP	10...30 VDC	150 DC, (K)	
		3, 	 , NPN	10...30 VDC	150 DC, (K)	
		<i>uprox</i> [®] +	6, 	 , PNP	10...30 VDC	150 DC, (K)
		<i>uprox</i> [®] +	6, 	 , PNP	10...30 VDC	150 DC, (K)
		<i>uprox</i> [®] +	6, 	 , NPN	10...30 VDC	150 DC, (K)
		-	3, 	 , PNP	10...30 VDC	150 DC, (K)
		-	3, 	 , NPN	10...30 VDC	150 DC, (K)
		Ex II 2 G SIL2	1.5, 	NAMUR	nom. 8.2 VDC	-
		Sn +	2, 	 , PNP	10...30 VDC	150 DC, (K)
		Sn +	2, 	 , PNP	10...30 VDC	150 DC, (K)
		Sn +	2, 	 , NPN	10...30 VDC	150 DC, (K)
		-	1.5, 	 , PNP	10...30 VDC	150 DC, (K)
		-	1.5, 	 , NPN	10...30 VDC	150 DC, (K)
		Ex II 2 G SIL2	1.5, 	NAMUR	nom. 8.2 VDC	-
		-	1.5, 	 , PNP	10...30 VDC	150 DC, (K)
		-	1.5, 	 , NPN	10...30 VDC	150 DC, (K)
		<i>uprox</i> [®] +	2, 	 , PNP	10...30 VDC	150 DC, (K)
		<i>uprox</i> [®] +	2, 	 , PNP	10...30 VDC	150 DC, (K)
		<i>uprox</i> [®] +	2, 	 , NPN	10...30 VDC	150 DC, (K)
		Sn +	2, 	 , PNP	10...30 VDC	150 DC, (K)
		Sn +	2, 	 , NPN	10...30 VDC	150 DC, (K)

型号	订货号	连接方式 (☞ 322)	开关频率 [kHz]	温度范围 [°C]	防护等级	外壳 (☞ 334)	感应面 (☞ 334)	导线 (☞ 334)	LED U _B	LED ┘
NI3-EH6,5K-AP6X-V1131	4610220	S002	3	-25...+70	IP67	VA	PA	-	-	•
NI3-EH6,5K-AN6X-V1131	4610320	S005	3	-25...+70	IP67	VA	PA	-	-	•
NI6U-EH6,5-AP6X-V1131	4631510 ✘	S002	1	-25...+70	IP68	VA	PA	-	-	•
NI6U-EH6,5-RP6X-V1131	4635832	S175	1	-25...+70	IP68	VA	PA	-	-	•
NI6U-EH6,5-AN6X-V1131	4631530	S005	1	-25...+70	IP68	VA	PA	-	-	•
NI3-EH6,5-AP6X-V1131	4612420 ✘	S002	3	-25...+70	IP67	VA	PA	-	-	•
NI3-EH6,5-AN6X-V1131	4612520	S005	3	-25...+70	IP67	VA	PA	-	-	•
BI1,5-EH6,5K-Y1	1004600 ✘	S025	5	-25...+70	IP67	VA	PA	PVC 2 m	-	-
BI2-EH6,5K-AP6X	4610000 ✘	S001	3	-25...+70	IP67	VA	PA	PUR 2 m	-	•
BI2-EH6,5K-RP6X	4610001	S054	3	-25...+70	IP67	VA	PA	PUR 2 m	-	•
BI2-EH6,5K-AN6X	4610100	S004	3	-25...+70	IP67	VA	PA	PUR 2 m	-	•
BI1,5-EH6,5K-AP6X	4610540 ✘	S001	3	-25...+70	IP67	VA	PA	PUR 2 m	-	•
BI1,5-EH6,5K-AN6X	4610640 ✘	S004	3	-25...+70	IP67	VA	PA	PUR 2 m	-	•
BI1,5-HS865-Y1	1004201	S025	5	-25...+70	IP67	CuZn-Cr	PA	PVC 2 m	-	-
BI1,5-HS865-AP6X	4604201 ✘	S001	3	-25...+70	IP67	CuZn-Cr	PA	PUR 2 m	-	•
BI1,5-HS865-AN6X	4604301	S004	3	-25...+70	IP67	CuZn-Cr	PA	PUR 2 m	-	•
BI2U-EH6,5-AP6X	4281150 ✘	S001	2	-30...+85	IP68	VA	PA	PUR 2 m	-	•
BI2U-EH6,5-RP6X	4281151	S054	2	-30...+85	IP68	VA	PA	PUR 2 m	-	•
BI2U-EH6,5-AN6X	4281170 ✘	S004	2	-30...+85	IP68	VA	PA	PUR 2 m	-	•
BI2-EH6,5-AP6X	4612200 ✘	S001	3	-25...+70	IP67	VA	PA	PUR 2 m	-	•
BI2-EH6,5-AN6X	4612300 ✘	S004	3	-25...+70	IP67	VA	PA	PUR 2 m	-	•

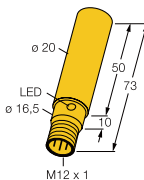
✘ = 优选型号

2

电感式传感器

尺寸/外形	特性	额定工作距离Sn [mm]	输出	工作电压	额定工作电流I _e [mA]	
	Ø6,5 	Ⓢ II 2 G SIL2	3, 	NAMUR	nom. 8.2 VDC	-
	Ø6,5 	-	3, 	 , PNP  , NPN	10...30 VDC	200 DC, Ⓢ
	Ø6,5 	<i>uprox</i> [®] + <i>uprox</i> [®] +	6,  6, 	 , PNP  , NPN	10...30 VDC	150 DC, Ⓢ
	Ø6,5 	-	3, 	 , PNP	10...30 VDC	150 DC, Ⓢ
	Ø6,5 	-	3, 	 , NPN	10...30 VDC	150 DC, Ⓢ
	Ø6,5 	-	3, 	 , NPN	10...30 VDC	150 DC, Ⓢ
	Ø11 	Ⓢ II 2 G SIL2	2, 	NAMUR	nom. 8.2 VDC	-
	Ø11 	-	2, 	 , PNP	10...30 VDC	200 DC, Ⓢ
	Ø11 	Ⓢ II 2 G SIL2	5, 	NAMUR	nom. 8.2 VDC	-
	Ø11 	-	5, 	 , PNP	10...30 VDC	200 DC, Ⓢ
	Ø11 	-	2, 	 , PNP	10...30 VDC	200 DC, Ⓢ
	Ø11 	-	5, 	 , PNP	10...30 VDC	200 DC, Ⓢ
	Ø20 	-	10, 	 , PNP	10...30 VDC	200 DC, Ⓢ
Ø20 	-	10, 	 , PNP	10...30 VDC	200 DC, Ⓢ	

固定支架包含在内











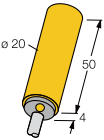







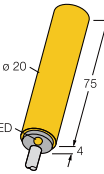



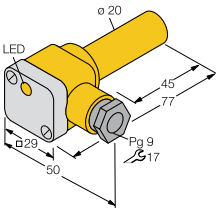















固定支架包含在内

固定支架包含在内

型号	订货号	连接方式 (☞ 322)	开关频率 [kHz]	温度范围 [°C]	防护等级	外壳 (☞ 334)	感应面 (☞ 334)	导线 (☞ 334)	LED U _B	LED ┘
NI3-EH6,5K-Y1	1004700 ✕	S025	5	-25...+70	IP67	VA	PA	PVC 2 m	-	-
NI3-EH6,5K-AP6X	4610200 ✕	S001	3	-25...+70	IP67	VA	PA	PUR 2 m	-	•
NI3-EH6,5K-AN6X	4610300	S004	3	-25...+70	IP67	VA	PA	PUR 2 m	-	•
NI6U-EH6,5-AP6X	4631500 ✕	S001	1	-25...+70	IP68	VA	PA	PUR 2 m	-	•
NI6U-EH6,5-AN6X	4631520	S004	1	-25...+70	IP68	VA	PA	PUR 2 m	-	•
NI3-EH6,5-AP6X	4612400 ✕	S001	3	-25...+70	IP67	VA	PA	PUR 2 m	-	•
NI3-EH6,5-AN6X	4612500	S004	3	-25...+70	IP67	VA	PA	PUR 2 m	-	•
BI2-K11-Y1	10070 ✕	S025	5	-25...+70	IP67	PA	PA	PVC 2 m	-	-
BI2-K11-AP6X	46609 ✕	S001	2	-25...+70	IP67	PA	PA	PVC 2 m	-	•
NI5-K11-Y1	10071 ✕	S025	2	-25...+70	IP67	PA	PA	PVC 2 m	-	-
NI5-K11-AP6X	46611 ✕	S001	1.5	-25...+70	IP67	PA	PA	PVC 2 m	-	•
BI2-K11SK-AP6X	46615 ✕	S003	2	-25...+70	IP67	PA	PA	-	-	•
NI5-K11SK-AP6X	46617 ✕	S003	1.5	-25...+70	IP67	PA	PA	-	-	•
NI10-K20-AP6X-H1141	4664200	S002	1	-25...+70	IP67	PBT	PBT	-	-	•

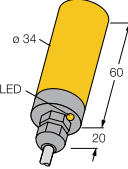
✕ = 优选型号

电感式传感器









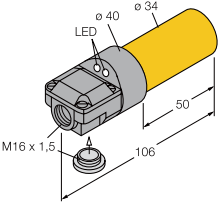

尺寸/外形		特性	额定工作 距离Sn [mm]	输出	工作电压	额定工作 电流 I _e [mA]	
		Ex II 2 G SIL2	10, 	NAMUR	nom. 8.2 VDC	-	
		-	10, 	 , PNP	10...30 VDC	200 DC, 	
		-	10, 	 , NPN	10...30 VDC	200 DC, 	
		-	10, 		20...250 VAC 10...300 VDC	400 AC 300 DC	
		<i>uprox</i> [®]	5, 	 , PNP	10...30 VDC	200 DC, 	
		<i>uprox</i> [®]	5, 		10...30 VDC	200 DC, 	
		<i>uprox</i> [®]	12, 	 , PNP	10...30 VDC	200 DC, 	
		<i>uprox</i> [®]	12, 		10...30 VDC	200 DC, 	
		-	10, 	 , PNP	10...30 VDC	200 DC, 	
		-	10, 		10...30 VDC	200 DC, 	
		-	10, 		20...250 VAC 10...300 VDC	400 AC 300 DC	
		-	20, 	 , PNP	10...65 VDC	200 DC, 	

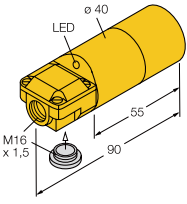
固定支架包含在内

型号	订货号	连接方式 (☞ 322)	开关频率 [kHz]	温度范围 [°C]	防护等级	外壳 (☞ 334)	感应面 (☞ 334)	导线 (☞ 334)	LED U _B	LED ┘
NI10-K20-Y1	10072 ✕	S025	0.5	-25...+70	IP67	PBT	PBT	PVC 2 m	-	-
NI10-K20-AP6X	46640 ✕	S001	1	-25...+70	IP67	PBT	PBT	PVC 2 m	-	•
NI10-K20-AN6X	46641 ✕	S004	1	-25...+70	IP67	PBT	PBT	PVC 2 m	-	•
NI10-K20-AZ3X	43585 ✕	S092	0.02	-25...+70	IP67	PBT	PBT	PVC 2 m	-	•
BI5U-K20SK-AP6X	1635130 ✕	S003	1	-30...+85	IP68	PBT	PBT	-	-	•
BI5U-K20SK-AN6X	1635131	S006	1	-30...+85	IP68	PBT	PBT	-	-	•
NI12U-K20SK-AP6X	1645330 ✕	S003	1	-30...+85	IP68	PBT	PBT	-	-	•
NI12U-K20SK-AN6X	1645331	S006	1	-30...+85	IP68	PBT	PBT	-	-	•
NI10-K20SK-AP6X	46646 ✕	S003	1	-25...+70	IP67	PBT	PBT	-	-	•
NI10-K20SK-AN6X	46648	S006	1	-25...+70	IP67	PBT	PBT	-	-	•
NI10-K20SK-AZ3X	43591 ✕	S095	0.02	-25...+70	IP67	PBT	PBT	-	-	•
NI20-K34-VP4X	1565602 ✕	S007	0.5	-25...+70	IP67	PBT	PBT	PVC 2 m	-	•

✕ = 优选型号

电感式传感器

尺寸/外形	特性	额定工作距离Sn [mm]	输出	工作电压	额定工作电流I _e [mA]		
	Ø34	-	-	10...65 VDC	200 DC, (⊗)		
		-	20, 	 , PNP	10...65 VDC	200 DC, (⊗)	
	Ø40	转速监控	15, 	10...65 VDC	200 DC, (⊗)		
		转速监控	30, 	 , NPN	10...65 VDC	200 DC, (⊗)	
		-	30, 	 , PNP	10...65 VDC	200 DC, (⊗)	
		-	30, 	 , NPN	10...65 VDC	200 DC, (⊗)	
		-	30, 	program.	20...250 VAC 10...300 VDC	400 AC 300 DC	
		-	20, 	 , PNP	10...30 VDC	200 DC, (⊗)	
		-	20, 	 , PNP	10...65 VDC	200 DC, (⊗)	
		-	20, 	 , NPN	10...30 VDC	200 DC, (⊗)	
		-	20, 	 , NPN	10...65 VDC	200 DC, (⊗)	
		-	20, 	program.	20...250 VAC 10...300 VDC	400 AC 300 DC	

固定支架包含在内

型号	订货号	连接方式 (☞ 322)	开关频率 [kHz]	温度范围 [°C]	防护等级	外壳 (☞ 334)	感应面 (☞ 334)	导线 (☞ 334)	LED U _B	LED ┘
NI20-K34SR-VP4X2	1565601 ✘	S009	0.5	-25...+70	IP67	PBT	PBT	-	•	•
DBI15U-K40SR-AP4X2	1500201	S058	-	-30...+85	IP67	ABS	ABS	-	•	•
DNI30U-K40SR-AP4X2	1500202	S058	-	-30...+85	IP67	ABS	ABS	-	•	•
NI30-K40SR-VP4X2	15658 ✘	S009	0.1	-25...+70	IP67	ABS	ABS	-	•	•
NI30-K40SR-VN4X2	15758 ✘	S012	0.1	-25...+70	IP67	ABS	ABS	-	•	•
NI30-K40SR-FZ3X2	13425 ✘	S016	0.02	-25...+70	IP67	ABS	ABS	-	•	•
NI20-K40SR-AP6X	16026 ✘	S003	0.1	-25...+70	IP67	ABS	ABS	-	-	•
NI20-K40SR-VP4X2	15656 ✘	S009	0.1	-25...+70	IP67	ABS	ABS	-	•	•
NI20-K40SR-AN6X	16226 ✘	S006	0.1	-25...+70	IP67	ABS	ABS	-	-	•
NI20-K40SR-VN4X2	15756 ✘	S012	0.1	-25...+70	IP67	ABS	ABS	-	•	•
NI20-K40SR-FZ3X2	13424 ✘	S016	0.02	-25...+70	IP67	ABS	ABS	-	•	•

✘ = 优选型号

环型电感式传感器

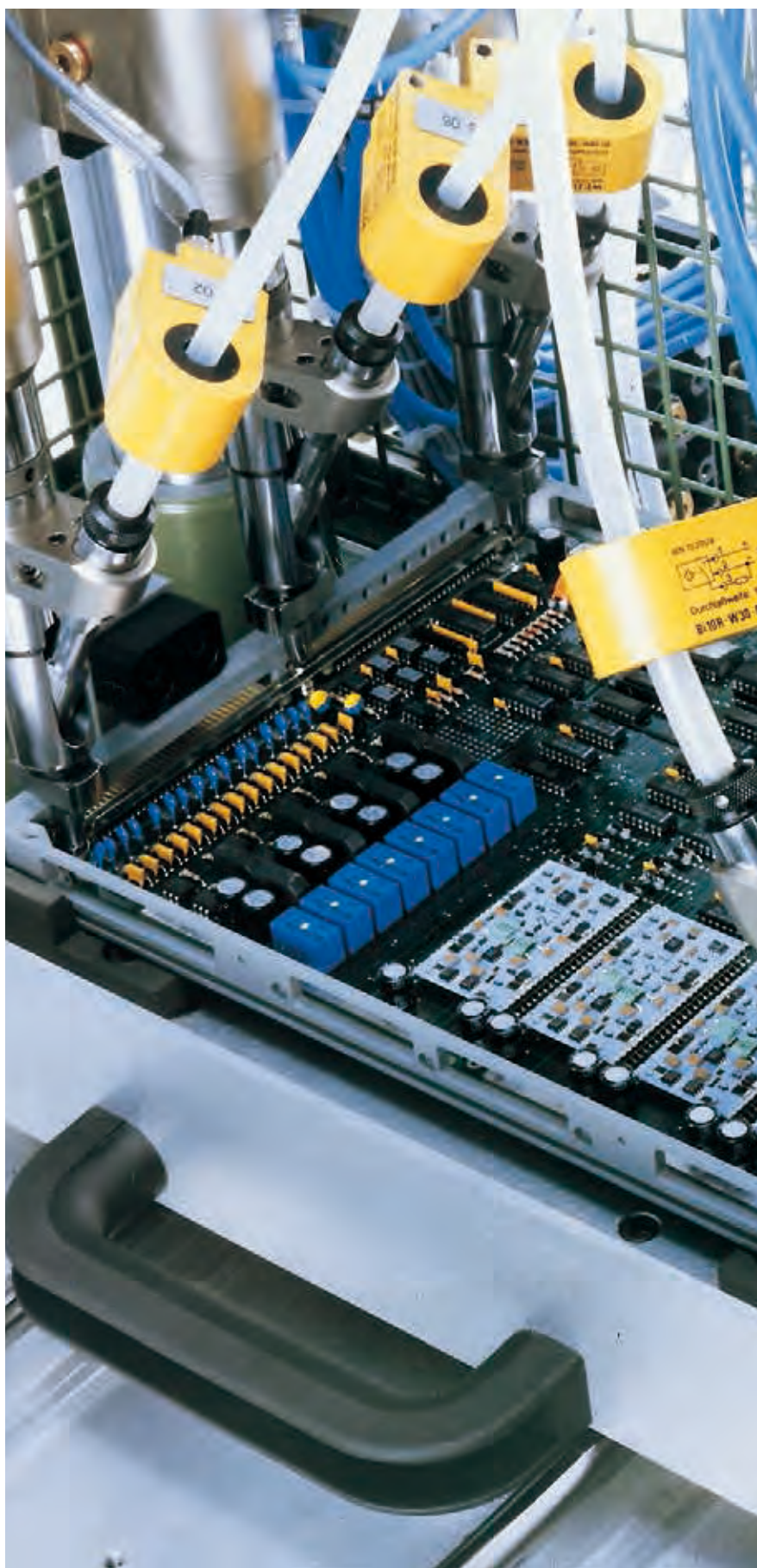

环型电感式传感器在部件的传输和装配工艺中尤其适合检测小型和快速运动的金属部件。在金属螺钉的安装的工序中能保证工程的稳定性。从而保证机器的正常运行和正确安装。环型电感式传感器能快速、可靠的安装在管状结构上，准确地检测螺钉、铆钉以及各种小型金属部件。

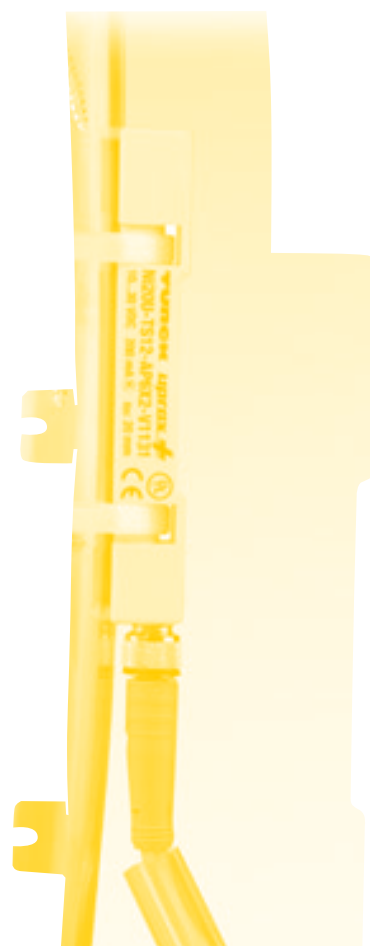

环型电感式传感器有静态/动态开关量输出和模拟量电压输出。动态环型传感器非常灵敏，并产生一个很短的脉冲（TURCK: 100ms）。在部件输送应用中尤其适合检测小的和快速运动的部件。静态环型传感器当金属部件在其环型圈内时，能产生一个连续的脉冲。这种开关有着更广泛的应用，如：在输送管路中铆钉和螺钉自动设备中的部件检测、部件阻塞检测、断线检测等。





TS12型传感器是为了替代不同型号的环型传感器而开发出来的创新型产品。这种uprox®+传感器被用来检测小的、快速运动的金属物体，并且该传感器具备了uprox®+的特性：衰减系数恒为1。TS12型传感器使用两条扎带直接安装在管状结构上，无需复杂的安装程序，提高了工作效率。小型化、高防护等级的设计使其易于维护，坚固耐用。

模拟量输出型环型传感器的控制器能够根据不同的高度产生不同的电压信号，锥形物体的简单行程测量能被检测出来。厚度测量（模拟量输出型）输送管中的部件的检测，断线检测，模拟量环型电感式传感器不仅用来识别线和螺钉的不同厚度和尺寸，也用来检测同种类型不同材质的部件。

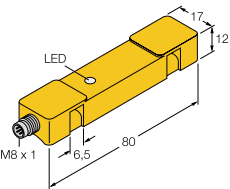
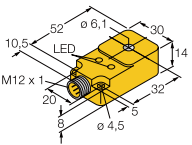
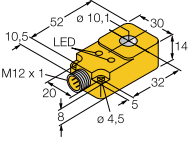
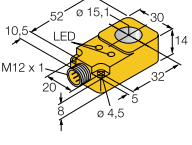
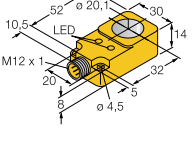
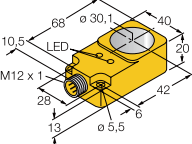
- 环型直径6...100 mm
- 静态、动态和模拟量输出型
- 内置放大器
- 高灵敏度，可调灵敏度
- 紧凑型外壳
- 创新型uprox®+系列TS12型











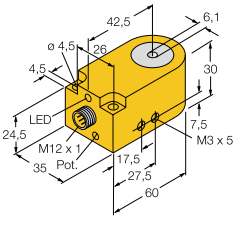

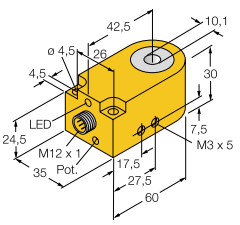
环型电感式传感器

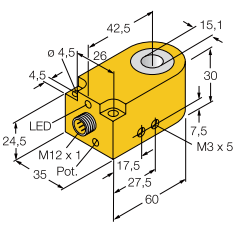
尺寸/外形	特性	环形内径 [mm]	目标直径 (最小) K: 钢球 D: 钢丝 [mm]	输出	工作电压	额定工作 电流 I_e [mA]
	TS12 □ →	-	-	—, PNP	10...30 VDC	200 DC, (K)
	<i>uprox</i> [®] +	-	-	—, NPN	10...30 VDC	200 DC, (K)
	Q14 □ →	6.1	2 K	—, PNP	10...30 VDC	200 DC, (K)
	静态输出	6.1	2 K	—, NPN	10...30 VDC	200 DC, (K)
	Q14 □ →	10.1	2 K	—, PNP	10...30 VDC	200 DC, (K)
	静态输出	10.1	2 K	—, NPN	10...30 VDC	200 DC, (K)
	Q14 □ →	15.1	3 K	—, PNP	10...30 VDC	200 DC, (K)
	静态输出	15.1	3 K	—, NPN	10...30 VDC	200 DC, (K)
	Q14 □ →	20.1	4 K	—, PNP	10...30 VDC	200 DC, (K)
	静态输出	20.1	4 K	—, NPN	10...30 VDC	200 DC, (K)
	Q20 □ →	30.1	6 K	—, PNP	10...30 VDC	200 DC, (K)
	静态输出	30.1	6 K	—, NPN	10...30 VDC	200 DC, (K)

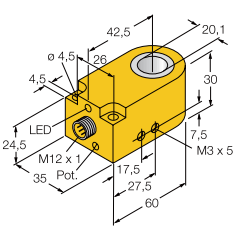
型号	订货号	连接方式	开关频率	温度范围	防护等级	外壳	感应面	导线	LED	LED
		()	[kHz]	[°C]		()	()	()	U _B	
NI20U-TS12-AP6X2-V1131	1646640 x	S002	0.008	-25...+70	IP68	PBT	-	-	•	•
NI20U-TS12-AN6X2-V1131	1625822	S005	0.008	-25...+70	IP68	PBT	-	-	•	•
BI6R-Q14-AP6X2-H1141	1407000 x	S002	0.008	-25...+70	IP67	PBT	POM	-	•	•
BI6R-Q14-AN6X2-H1141	1407020	S005	0.008	-25...+70	IP67	PBT	POM	-	•	•
BI10R-Q14-AP6X2-H1141	1407100 x	S002	0.008	-25...+70	IP67	PBT	POM	-	•	•
BI10R-Q14-AN6X2-H1141	1407120	S005	0.008	-25...+70	IP67	PBT	POM	-	•	•
BI15R-Q14-AP6X2-H1141	1407200 x	S002	0.008	-25...+70	IP67	PBT	POM	-	•	•
BI15R-Q14-AN6X2-H1141	1407220	S005	0.008	-25...+70	IP67	PBT	POM	-	•	•
BI20R-Q14-AP6X2-H1141	1407300 x	S002	0.008	-25...+70	IP67	PBT	POM	-	•	•
BI20R-Q14-AN6X2-H1141	1407320 x	S005	0.008	-25...+70	IP67	PBT	POM	-	•	•
BI30R-Q20-AP6X2-H1141	1407500 x	S002	0.008	-25...+70	IP67	PBT	POM	-	•	•
BI30R-Q20-AN6X2-H1141	1407520	S005	0.008	-25...+70	IP67	PBT	POM	-	•	•

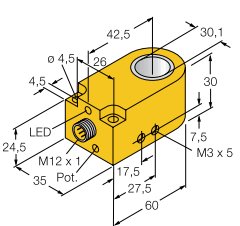
x = 优选型号

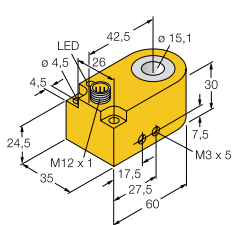
环型电感式传感器









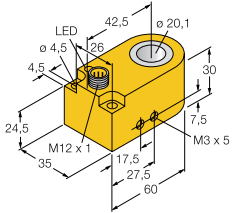

尺寸/外形	特性	环形内径 [mm]	目标直径 (最小) K: 钢球 D: 钢丝 [mm]	输出	工作电压	额定工作 电流 I_e [mA]	
	W30 	动态输出	6.1	0.6 K	—, PNP	10...30 VDC	200 DC, (K)
		动态输出	6.1	0.6 K	—, NPN	10...30 VDC	200 DC, (K)
	W30 	动态输出	10.1	1 K	—, PNP	10...30 VDC	200 DC, (K)
		动态输出	10.1	1 K	—, NPN	10...30 VDC	200 DC, (K)
	W30 	动态输出	15.1	1.5 K	—, PNP	10...30 VDC	200 DC, (K)
		动态输出	15.1	1.5 K	—, NPN	10...30 VDC	200 DC, (K)
	W30 	动态输出	20.1	2 K	—, PNP	10...30 VDC	200 DC, (K)
		动态输出	20.1	2 K	—, NPN	10...30 VDC	200 DC, (K)
	W30 	动态输出	30.1	3 K	—, PNP	10...30 VDC	200 DC, (K)
		动态输出	30.1	3 K	—, NPN	10...30 VDC	200 DC, (K)
	W30S 	静态输出	15.1	3 K	—, PNP	10...30 VDC	200 DC, (K)

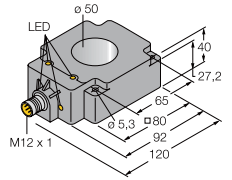
W30及W30S型参见136页

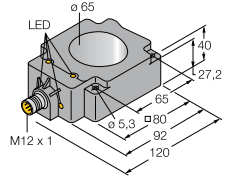
型号	订货号	连接方式 (☞ 322)	开关频率 [kHz]	温度范围 [°C]	防护等级	外壳 (☞ 334)	感应面 (☞ 334)	导线 (☞ 334)	LED U _B	LED ┘
BI6R-W30-DAP6X-H1141	14036 x	S002	0.008	-25...+70	IP67	PA	POM	-	-	•
BI6R-W30-DAN6X-H1141	14037	S005	0.008	-25...+70	IP67	PA	POM	-	-	•
BI10R-W30-DAP6X-H1141	14038 x	S002	0.008	-25...+70	IP67	PA	POM	-	-	•
BI10R-W30-DAN6X-H1141	14039 x	S005	0.008	-25...+70	IP67	PA	POM	-	-	•
BI15R-W30-DAP6X-H1141	14040 x	S002	0.008	-25...+70	IP67	PA	POM	-	-	•
BI15R-W30-DAN6X-H1141	14041	S005	0.008	-25...+70	IP67	PA	POM	-	-	•
BI20R-W30-DAP6X-H1141	14042 x	S002	0.008	-25...+70	IP67	PA	POM	-	-	•
BI20R-W30-DAN6X-H1141	14043 x	S005	0.008	-25...+70	IP67	PA	POM	-	-	•
BI30R-W30-DAP6X-H1141	14045 x	S002	0.008	-25...+70	IP67	PA	POM	-	-	•
BI30R-W30-DAN6X-H1141	1404501	S005	0.008	-25...+70	IP67	PA	POM	-	-	•
BI15R-W30S-AP6X-H1141	1404031 x	S002	0.008	-25...+70	IP67	PA	POM	-	-	•

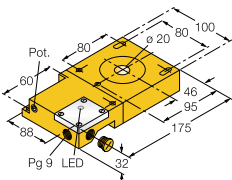
x = 优选型号

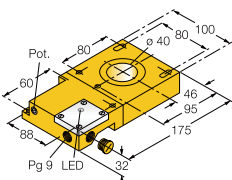
环型电感式传感器

尺寸/外形	特性	环形内径 [mm]	目标直径 (最小) K: 钢球 D: 钢丝 [mm]	输出	工作电压	额定工作 电流 I_e [mA]
	W30S 	20.1	4 K	—, PNP	10...30 VDC	200 DC, (K)
	Q80 	50	8 K	—, PNP	10...30 VDC	200 DC, (K)
	Q80 	65	10 K	—, PNP	10...30 VDC	200 DC, (K)
	S32SR 	20	0.4 D	—, PNP	10...55 VDC	200 DC, (K)
	S32SR 	40	1 D	—, PNP	10...55 VDC	200 DC, (K)

环型传感器W30和W30S的安装附件在“附件”章节有描述。

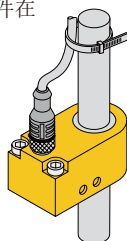



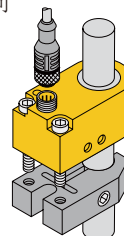



当使用W30S型号时，导线可以紧贴管道安装。



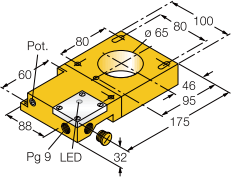

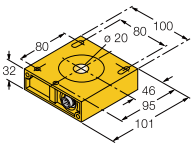
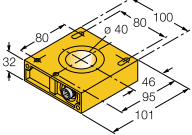
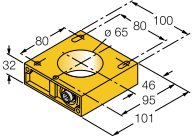
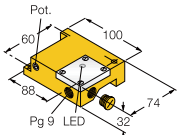

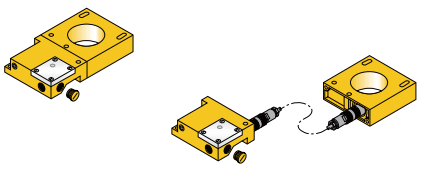
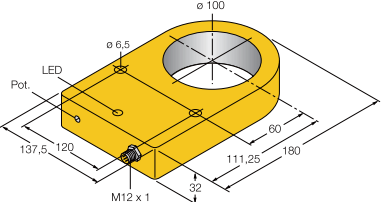





型号	订货号	连接方式 (☞ 322)	开关频率 [kHz]	温度范围 [°C]	防护等级	外壳 (☞ 334)	感应面 (☞ 334)	导线 (☞ 334)	LED U _B	LED ┘
BI20R-W30S-AP6X-H1141	1403231 ✕	S002	0.008	-25...+70	IP67	PA	POM	-	-	•
BI50R-Q80-AP6X2-H1141	1407530 ✕	S002	0.01	-25...+70	IP67	PBT	PA	-	•	•
BI65R-Q80-AP6X2-H1141	1407531 ✕	S002	0.01	-25...+70	IP67	PBT	PA	-	•	•
NI20R-S32SR-VP44X	1440001 ✕	S009	0.008	-25...+70	IP65	ABS	ABS	-	-	•
NI40R-S32SR-VP44X	1440005 ✕	S009	0.008	-25...+70	IP65	ABS	ABS	-	-	•

✕ = 优选型号

环型电感式传感器

尺寸/外形	特性	环形内径 [mm]	目标直径 (最小) K: 钢球 D: 钢丝 [mm]	输出	工作电压	额定工作 电流 I _e [mA]	
	S32SR 	65	2 D	 , PNP	10...55 VDC	200 DC, (⊗)	
	S32	20	0.4 D	-	-	-	
	S32	40	1 D	-	-	-	
	S32	65	2 D	-	-	-	
	S32 	-	-	 , PNP	10...55 VDC	200 DC, (⊗)	 <p>环形传感器S32可以作为整体安装，也可以通过一根适配线与放大器配和使用。</p>
	S32XL 	100	10 K / 4 D	 , PNP	10...55 VDC	200 DC, (⊗)	

型号	订货号	连接方式 ()	开关频率 [kHz]	温度范围 [°C]	防护等级	外壳 ()	感应面 ()	导线 ()	LED U _B	LED 
NI65R-S32SR-VP44X	1440008 	S009	0.008	-25...+70	IP65	ABS	POM	-	-	•
NI20R-	1410001 	-	-	-25...+70	IP65	ABS	ABS	-	-	-
NI40R-	1430101 	-	-	-25...+70	IP65	ABS	ABS	-	-	-
NI65R-	1440007 	-	-	-25...+70	IP65	ABS	POM	-	-	-
S32SR-VP44X	1440010 	S009	0.008	-25...+70	IP65	ABS	-	-	-	•
NI100R-S32XL-VP44X-H1141	1510301 	S008	0.008	-25...+70	IP67	POM	POM	-	-	•

 = 优选型号

环型电感式传感器

尺寸/外形	特性	检测范围 [mm]	测量尺寸 [mm]	输出 type 1 I (mA) (PIN2, WH)	输出 type 2 U (V) (PIN4, BK)	线性 误差 [%]	工作 电压U _B	
	Q14 	analog VA: 非铁磁金属 St37:	- 2...17mm 4...19mm 1...10mm	1)	1)	0...10 V	-	15...30 VDC
	Q14 	analog VA: 非铁磁金属 St37:	- 2...17mm 4...19mm 1...10mm	1)	1)	0...10 V	-	15...30 VDC

1) 参见320页

型号	订货号	连接方式 (IEC 322)	开关频率 [kHz]	温度范围 [°C]	防护等级	外壳 (IEC 334)	感应面 (IEC 334)	导线 (IEC 334)	LED U _B	LED └┘
BI20R-Q14-LU	1535546 x	S091	80	-25...+70	IP67	PBT	-	PVC 2 m	-	
BI20R-Q14-LU-H1141	1535548 x	S098	80	-25...+70	IP67	PBT	-	-	-	

原理示意图

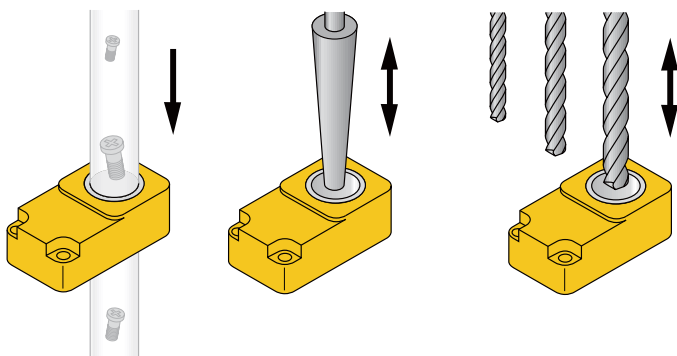

模拟量输出的环形电感式传感器的典型应用：
 —厚度检测（螺钉、铆钉、棒状材料）
 —锥体的行程检测，检测长度可以根据锥体长度自行设定
 —工件检测

x = 优选型号

槽型电感式传感器



槽型传感器呈“U”型，其检测面在两臂间，适于当物体从侧面接近时检测距离不能准确标定地场合，实现可靠检测。槽型传感器在模拟量指示设备上可被用来当作起点、终点位置传感器，也可在链条驱动的传送带系统上作纠偏传感器，这样，驱动元件可以籍由链条之间的偏差大小来进行左右摆动调节。



槽型传感器设计的槽宽范围为2~30mm，用户可以根据实际应用中不同的空间以及所需要的不同的精度来选择相对应的槽宽。所有2~30mm槽宽范围的传感器都包括本质安全型输出的产品，使得该类型的传感器可安全应用在爆炸危险系统中（SIL 2 ~ IEC 61508）此外，几种不同槽宽的传感器都具有PNP或NPN输出；更大的外壳形状设计，可以使此类槽型传感器可应用在250VAC的规格下。

金属检测对象在槽型传感器中的嵌入深度(Fig. 1 和 2)

系列	I [mm]	H [mm]	J [mm]	W [Material]	X [mm]	X [%]	Hyst. [%]	Hyst. [mm]	F [mm]
Si3,5	3,5	10	10	Alu	5...6	50...60	0...20	0...1,2	9,5
Si5	15	9	9	St37	3,7...5,2	41...58	< 40	< 1,5	8,5
Si15	30	42	30	St37	18...20	53,3...66,6	3...13,5	0,4...2,7	30
Si30	30	80	33	St37	16...18	48...54,5	3...15	0,48...2,7	40

齿型被测物的监测

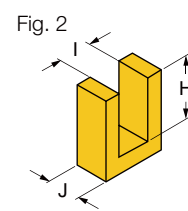
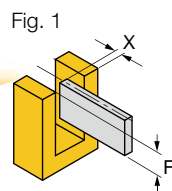

系列	A [mm]	B [mm]	C [mm]	E [mm]	F [mm]
Si3,5	4	2,5	11	0,2	10
Si5	5	3	11	0,2	9
Si15	16	10	35	1	30
Si30	24	10	45	0,5	40

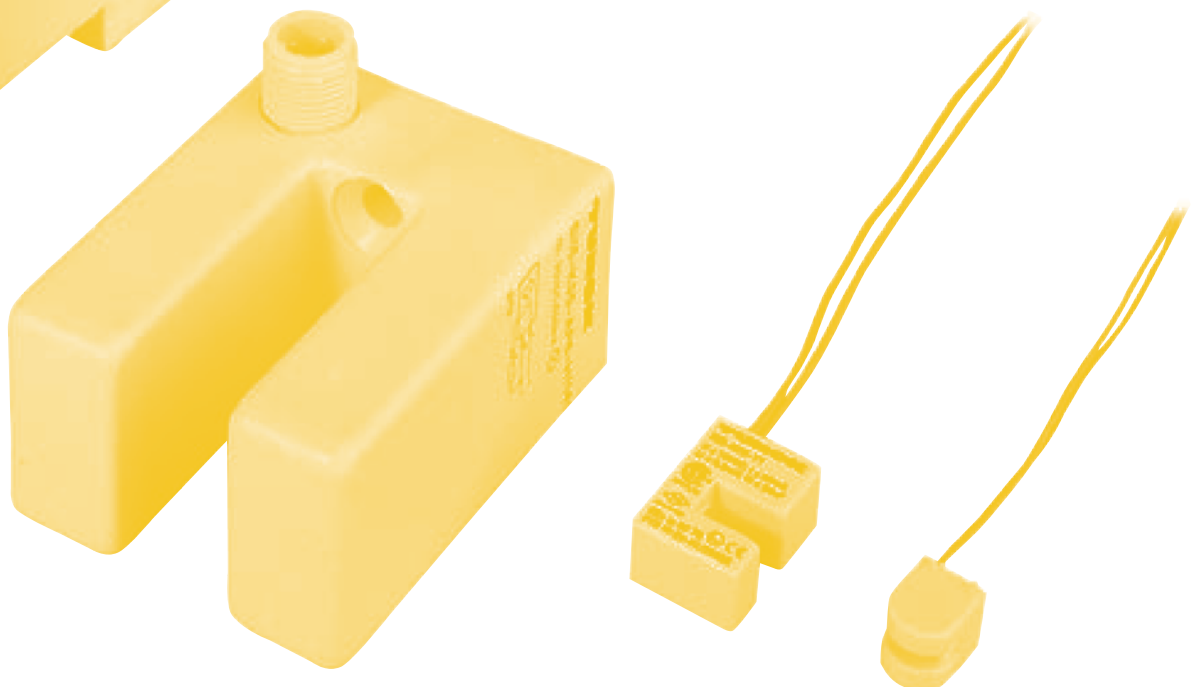
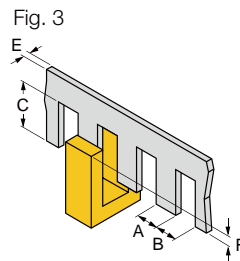

型号	订货号	连接方式 (☞ 322)	开关频率 [kHz]	温度范围 [°C]	防护等级	外壳 (☞ 334)	感应面 (☞ 334)	导线 (☞ 334)	LED U _B	LED ┘
SI2-K08-Y1	1007700 -	S025	2.5	-25...+70	IP67	VES	VES	PVC 0.5 m	-	-
SI2-K08-AP7	1719501 ✘	S001	1	-25...+70	IP67	VES	VES	PVC 0.5 m	-	-
SI2-K08-AN7	1719601 -	S004	1	-25...+70	IP67	VES	VES	PVC 0.5 m	-	-
SI5-K09-Y1	10075 ✘	S025	5	-25...+70	IP67	PBT	PBT	PVC 0.5 m	-	-
SI3,5-K10-Y1	10090 ✘	S025	3	-25...+70	IP67	PBT	PBT	PVC 0.5 m	-	-
SI3,5-K10-Y1X	40490 ✘	S025	3	-25...+70	IP67	PBT	PBT	PVC 0.5 m	-	●
SI3,5-K10-AP6X	1650001 ✘	S001	2	-25...+70	IP67	PBT	PBT	PVC 0.5 m	-	●
SI3,5-K10-AN7	1719000 ✘	S004	2	-25...+70	IP67	PBT	PBT	PVC 0.5 m	-	-
SI15-K30-Y1X	1007601 -	S025	0.5	-25...+70	IP67	PBT	PBT	PVC 2 m	-	●
SI15-K30-AP6X	1605001 ✘	S001	0.5	-25...+70	IP67	PBT	PBT	PVC 2 m	-	●
SI15-K30-AN6X	1605003 ✘	S004	0.5	-25...+70	IP67	PBT	PBT	PVC 2 m	-	●
SI15-K30-AZ3	13069 ✘	S092	0.02	-25...+70	IP67	PBT	PBT	PVC 2 m	-	-
SI15-K30-RZ3	13169 ✘	S094	0.02	-25...+70	IP67	PBT	PBT	PVC 2 m	-	-

✘ = 优选型号

3

夹钳位置控制型电感式传感器

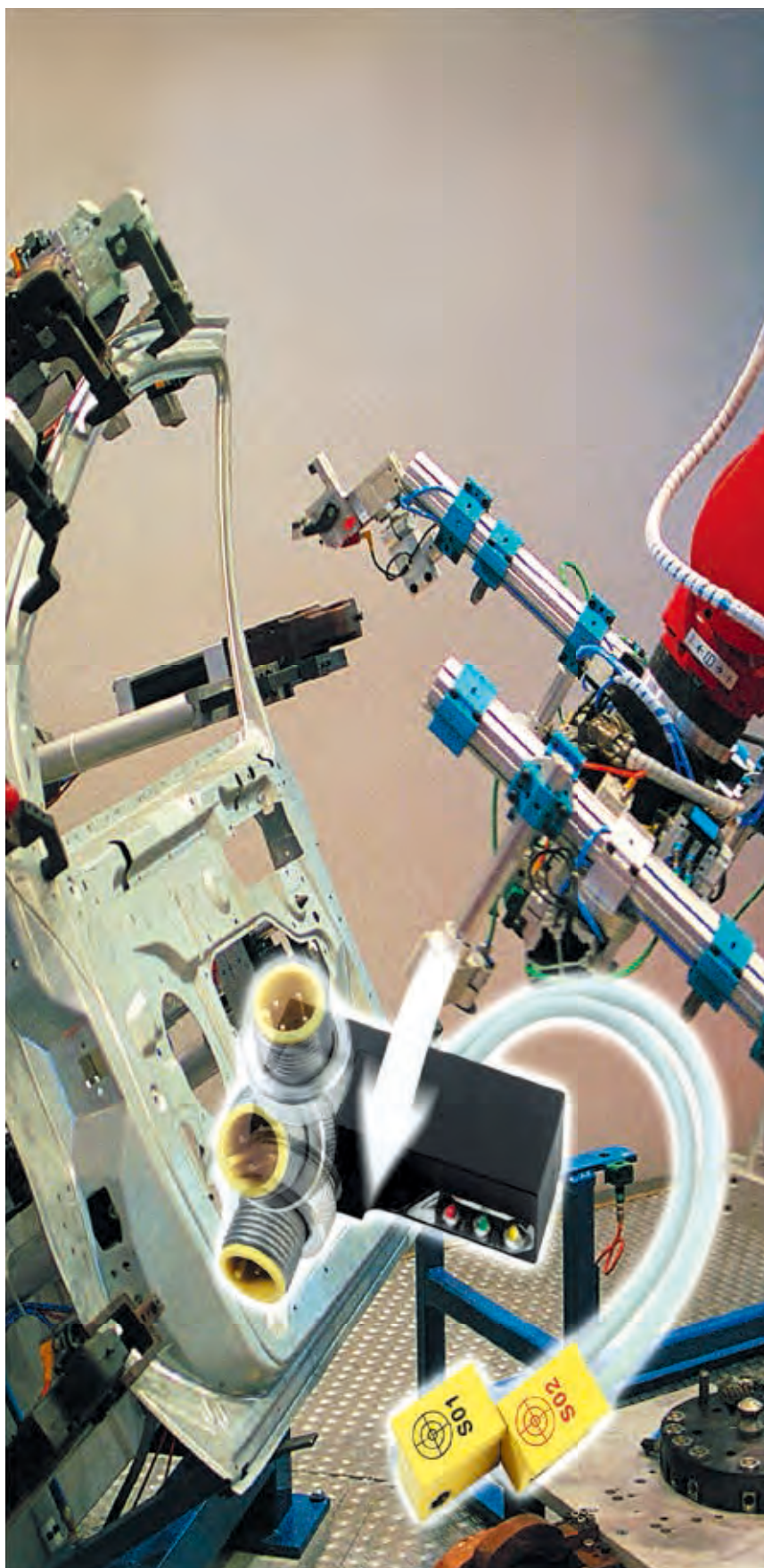

在所有的夹钳位置控制系统中，通过监控夹钳位置的“开”和“关”以确保生产过程的连续性，是很必要的。TURCK的夹钳位置控制型电感式传感器完全适于这种检测工作，这种传感器能被用于各种工业夹钳控制系统中（例如：在自动化工业中）。

新的BDS装置和BS模块包含独立的传感器模块，以致于TURCK的任一传感器型号都能与电源块结合使用。这确保适用于所有的夹钳控制系统，使客户能确信有一种方案来适配他的特殊需要。



TURCK的夹钳位置控制型传感器，包含一个电源模块和两个独立的电感式传感器模块。

• 传感器模块监控夹钳的“开”和“关”位置，这种应用目前应用最多的传感器类型是Q5.5, Q6.5, Q9.5, K08Q 和EH08/6.5，由于它使用了完整的传感器模块，所以也能迅速适配其他型号的传感器来使用。

• 电源模块通过一个单独的连接器和连接2个传感器，三个高度可视的指示灯现实“开”和“关”的位置，其中一个作为电源指示，为了最合理地布线，连接器为螺母状，并能不用工具以45°、90°角旋转。

• BS—电源模块的三个高度可视的LED指示灯可清晰显示传感器的状况和运行的电压强度。传感器有多种安装方式，通过在BS模块上的交叉安装孔可实现接插件的多位置连接（侧部和上部）

• BDS—带可调接口的电源模块，接口可不用工具调整至0°、45°或90°，因而可以进行灵活布线。LED高度可视，可从任何角度观察状态变化。

• BMI—轻量型紧凑型电源模块，倾斜45°的借口能适应绝大多数安装环境的需要。匹配不同的夹钳位置控制系统。LED指示灯高度可视，能从不同角度清晰观察传感器运行状况。

• KS13和KS26是夹钳控制传感器的一种，“开”和“关”位置被集成在一个模块内。并通过一个M12的连接线和插接件和系统连接。

根据型号和夹钳的构成以及特殊应用的需要，TURCK的夹钳位置控制型传感器既能通过插接形式被安装，也能通过直接机械结构来安装。这些灵活的安装有助于节约时间和经费。

您可以大量应用我们的夹钳控制技术，我们确保有一种合适的方案解决你的检测问题。

• 电源块有三个高度可视的指示灯，用于显示夹钳位置的“开”和“关”以及“电源”指示。

• 为确保最优布线，坚固的连接器安装角度可做0°、45°或90°的旋转，同时连接器可用双面导向装置和滚花螺母松开而不要借助额外的工具。

• 多种的电源模块和40多种的传感器模块可以无限组合。

• 有抗焊接应用型（抗磁场干扰）

• 不含卤素材质

• 几乎用于所有欧洲、美国和亚洲的自动化工厂

• 完善的适配装置可用于各种夹钳系统（BTM, Destaco, Festo, Genus, ISI, Tünkers 等）

• 具有2个监控位置应用的特定解决方案



夹钳位置控制型电感式传感器











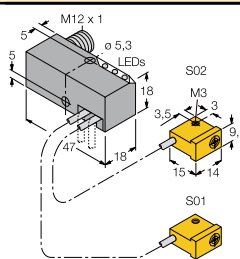







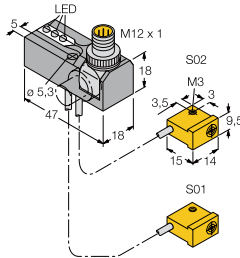



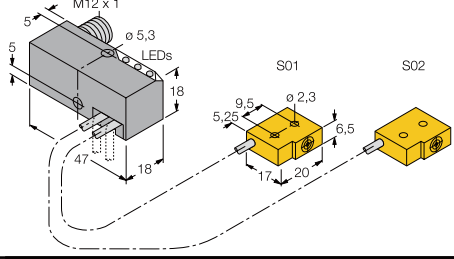



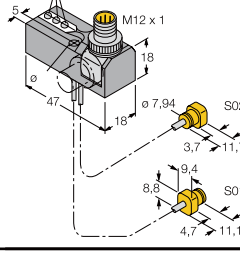

尺寸/外形	特性	额定工作距离Sn [mm]	输出	工作电压	额定工作电流Ie [mA]
	Q5,5 	2,		10...30 VDC	150 DC,
	Q6,5 	2,		10...30 VDC	150 DC,
	Q6,5 	2,		10...30 VDC	150 DC,
	Q6,5 	2,		10...30 VDC	150 DC,
	Q6,5 	2, 2,	2 x 2 x	20...250 VAC 10...300 VDC 20...250 VAC 10...300 VDC	100 AC 100 DC, 100 AC 100 DC,
	Q9,5 	2,		10...30 VDC	150 DC,

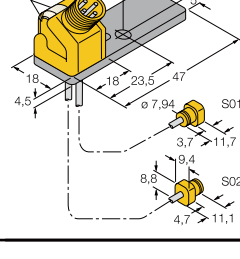
型号	订货号	连接方式 (☞ 322)	开关频率 [kHz]	温度范围 [°C]	防护等级	外壳 (☞ 334)	感应面 (☞ 334)	导线 (☞ 334)	LED U _B	LED ┘
BI2-Q5,5-0,27-BS-2AP6X3-H1141/S34	1613006	S046	0.03	-25...+70	IP67	PBT	PP	PUR 0,27 m	•	••
NI2-BMI-AP-002	1650251	S046	0.03	-25...+70	IP67	PP	PA	PUR 0.1 m / 0,1 m	•	••
NI2-Q6,5-AP6-0,1-FS4,4X3/S304	1650048	S046	0.03	-25...+70	IP67	PBT	PP	PUR 0.1 m	•	••
NI2-Q6,5-0,1-BDS-2AP6X3-H1141/S34	1650098 ✕	S046	0.03	-25...+70	IP67	Trogamit	PP	PUR 0.1 m	•	••
NI2-Q6,5-ADZ32-0,16-FSB5,4X4/ S304	4200203	S047	0.03	-25...+70	IP67	PBT	PP	PUR 0,16 m	-	••
NI2-Q6,5-ADZ32-0,1-FSB5,4X4/ S304	4200204	S047	0.03	-25...+70	IP67	PBT	PP	PUR 0,1 m	-	••
NI2-BMI-AP-001	1650250	S046	0.03	-25...+70	IP67	PP	PA	PUR 0.1 m / 0,1 m	•	••

✕ = 优选型号

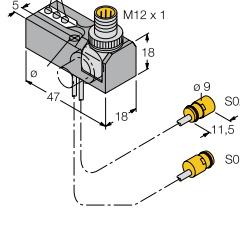
3

夹钳位置控制型电感式传感器

尺寸/外形	特性	额定工作距离Sn [mm]	输出	工作电压	额定工作电流Ie [mA]	
	Q9,5 	2, 	—, PNP	10...30 VDC	150 DC, 	
	抗磁场干扰	2, 	—, PNP	10...30 VDC	150 DC, 	
	抗磁场干扰	2, 	—, PNP	10...30 VDC	150 DC, 	
	Q9,5 	2, 	—, PNP	10...30 VDC	150 DC, 	
	Q6,5 	2, 	—, PNP	10...30 VDC	150 DC, 	
	K08Q 	1,2, 	—, PNP	10...30 VDC	200 DC, 	
	K08Q 	2, 	—, PNP	10...30 VDC	150 DC, 	
	K09 	1,2, 	—, PNP	10...30 VDC	200 DC, 	

型号	订货号	连接方式 (☞ 322)	开关频率 [kHz]	温度范围 [°C]	防护等级	外壳 (☞ 334)	感应面 (☞ 334)	导线 (☞ 334)	LED U _B	LED ┌┐
NI2-Q9,5-AP6-0,1-FS4,4X3/S304	1650060 x	S046	0.03	-25...+70	IP67	PBT	PP	PUR 0.1 m	•	••
NI2-Q9,5-AP6-0,2-FS4,4X3/S304	1650062 x	S046	0.03	-25...+70	IP67	PBT	PP	PUR 0.2 m	•	••
NI2-Q9,5-AP6-0,15-FS4,4X3/S304	1650065	S046	0.03	-25...+70	IP67	PBT	PP	PUR 0.15 m	•	••
NI2-Q9,5-0,1-BDS-2AP6X3-H1141/S34	1650099 x	S046	0.03	-25...+70	IP67	Trogamit	PP	PUR 0.1 m	•	••
NI2-Q6,5-AP6-0,15-FS4,4X3/S304	1650074	S046	0.03	-25...+70	IP67	PBT	PP	PUR 0.15 m	•	••
NI2-K08Q-0,095/0,11-BDS-2AP6X3-H1141/S34	1650124 x	S046	0.03	-25...+70	IP67	Trogamit	PA	PUR 0.095 m / 0.11 m	•	••
NI2-BMI-AP-003	1650252	S046	0.03	-25...+70	IP67	PP	PA	PUR 0.095 m / 0.11 m	•	••
NI2-K09-0,095/0,11-BDS-2AP6X3-H1141/S34	1650039 x	S046	0.03	-25...+70	IP67	Trogamit	PP	PUR 0.095 m / 0.11 m	•	••

x = 优选型号

型号	订货号	连接方式 (☞ 322)	开关频率 [kHz]	温度范围 [°C]	防护等级	外壳 (☞ 334)	感应面 (☞ 334)	导线 (☞ 334)	LED U _B	LED ┌
NI2-ISI-0,055-BDS-2AP6X3-H1141/S34	1650130 x	S046	0.03	-25...+70	IP67	Trogamit	PA	PUR 0.055 m	•	••
NI1,5-KS13A-2AP6X3-0,2-RS4,4T /S34	4430120	S029	0.5	-25...+70	IP67	PBT	PBT	PUR 0.2 m	•	••
NI1,5-KS13A-2AD4X2-0,2-RS4,4T /S34	4430115 x	S135	0.25	-25...+70	IP67	PBT	PBT	PUR 0.2 m	-	••
NI1,5-KS13R-2AD4X2-0,2-RS4,4T /S34	4430116	S135	0.25	-25...+70	IP67	PBT	PBT	PUR 0.2 m	-	••
NI1,5-KSR13R-2AD4X2-0,2-RS4,4T/S34	4430121	S135	0.25	-25...+70	IP67	PBT	PBT	PUR 0.2 m	-	••
NI1,5-KSR13A-2AD4X2-0,2-RS4,4T/S34	4430122	S135	0.25	-25...+70	IP67	PBT	PBT	PUR 0.2 m	-	••
NI1,5-KSR26R-2AD4X2-0,2-RS4,4T/S34	4430123	S135	0.25	-25...+70	IP67	PBT	PBT	PUR 0.2 m	-	••
NI1,5-KSR26A-2AD4X2-0,2-RS4,4T/S34	4430124	S135	0.25	-25...+70	IP67	PBT	PBT	PUR 0.2 m	-	••
NI1,5-VEP-2AP6-0,185-FS4,4X3/S304	1650123	S172	0.03	-25...+70	IP67	PBT	PBT	PUR 0.185 m	•	••

x = 优选型号

uprox[®] / uprox[®]+



新一代电感式传感器 **uprox[®]+**

与传统的铁氧体磁芯电感式传感器只能在标准检测物上表现出最大检测距离不同，TURCK开发的 **uprox[®]+** 传感器能对所有金属衰减系数恒为1，不论是铁、不锈钢、铜、铝、还是黄铜均能有相同的检测距离。

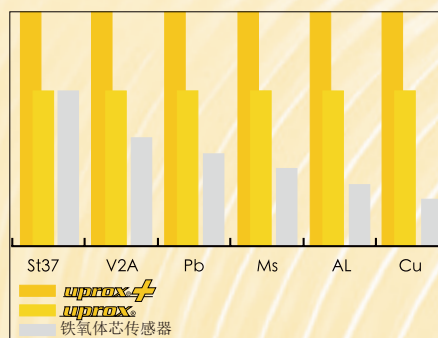

传统铁氧磁芯型传感器 vs 全金属检测型传感器

新型 **uprox[®]+** 传感器的发展清晰地证明了TURCK的创新水平。为了满足客户不断增长的需求，我们对已经广为认可的 **uprox[®]** 系列传感器进行持续的改进。请选用新一代 **uprox[®]+** 系列产品，从而获得极大的性能提升！

- 极大的开关距离：TURCK新型 **uprox[®]+** 系列传感器可实现 factor1 和超大开关距离检测。
- 针对标准系统结构的全面优化：一个 **uprox[®]+** 产品能够替代多个常规传感器型号。
- 在简化安装方式的前提下实现可靠的检测。
- 丰富的外壳形式给各种应用提供了最大的灵活性。
- 高等级的EMC特性和抗磁场干扰性能更加适应恶劣环境。

图尔克全新的电感式传感器的发展，印证了图尔克公司的创新水平。基于创新的线圈概念，全新的电感式传感器 **uprox[®]+** 具有无与伦比的性能特性。其核心技术是采用了具有专利技术的柔性多线圈系统代替了传统的空气线圈。极大的开关距离和独特的柔性封装使电感式传感器 **uprox[®]+** 成为迄今为止性能最好的全金属检测 FACTOR=1 的传感器。



极大的开关距离
全新的电感式传感器 *uprox* 比传统铁氧体磁芯电感式传感器最多提高250%的开关距离。能够在对全金属检测距离无衰减的情况下实现极大的开关距离。



真正的全金属检测—FACTOR=1的新定义基于创新性的线圈结构，全新的 *uprox* 电感式传感器可以实现真正意义上的全金属检测，它们能够以最高的检测精度实现对铁、铝、铜、黄铜和不锈钢等金属相同的超大检测距离。

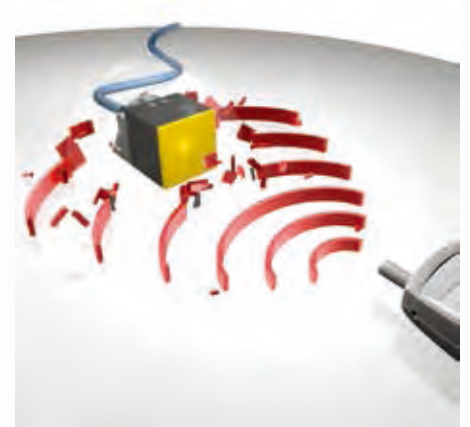

高等级的电磁兼容（EMC）特性
全新的电感式传感器 *uprox* 不但完全符合现有的标准EN60947-5-2,并能符合新版更加苛刻的标准EN61000-4-6.因此，电感式传感器 *uprox* 具有更好的抗干扰性能，如：变频干扰等。此外，使用新型的传感器也可以满足设备未来的需要。





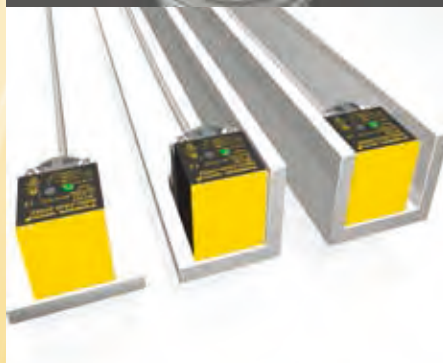







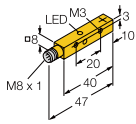



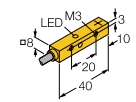



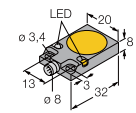

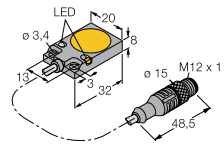

极高的抗电磁干扰性能
全新的电感式传感器 *uprox* 内部采用无铁氧体芯线圈，因而可有效地防止强磁场的干扰，如电焊过程中或者靠近升降梯和电磁炉的位置。

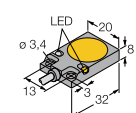

齐平传感器的沉入式安装
对新型 *uprox* 传感器安装只需要保持很小的金属自由区，为了获得更好的机械保护，此类传感器容许沉入半个螺纹安装，因而可保证任何安装条件下传感器的绝对安全！

非齐平传感器的部分嵌入式安装
非齐平 *uprox* 传感器通过集成预阻尼保护功能实现了独特的灵活性。与传统的铁芯线圈传感器相比具有更大的安装自由度而无需考虑金属支架的影响。一些新型产品甚至容许4面嵌入安装到金属中，开关距离会有相应的缩减。

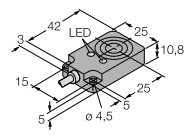









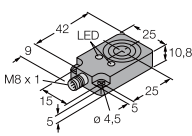



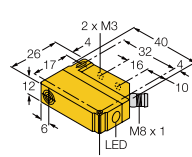



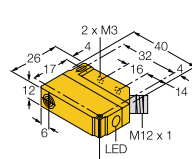

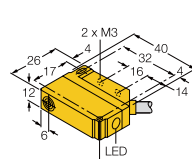

FACTOR1 *uprox*[®] / *uprox*[®]+

尺寸/外形	特性	额定工作 距离Sn [mm]	输出	工作电压	额定工作 电流Ie [mA]
	Q8SE □ →	<i>uprox</i> [®] +	4, 	—, PNP	10...30 VDC 150 DC, (K)
		<i>uprox</i> [®] +	4, 	—, PNP	10...30 VDC 150 DC, (K)
		<i>uprox</i> [®] +	4, 	—, NPN	10...30 VDC 150 DC, (K)
	Q8SE □ —	<i>uprox</i> [®] +	4,  / 	—, PNP	10...30 VDC 150 DC, (K)
		<i>uprox</i> [®] +	4,  / 	—, NPN	10...30 VDC 150 DC, (K)
	Q08 □ →	<i>uprox</i> [®] +	8, 	—, PNP	10...30 VDC 200 DC, (K)
		<i>uprox</i> [®] +	8, 	—, NPN	10...30 VDC 200 DC, (K)
		<i>uprox</i> [®]	5, 	—, PNP	10...30 VDC 200 DC, (K)
		<i>uprox</i> [®]	5, 	—, NPN	10...30 VDC 200 DC, (K)
	Q08 □ →	<i>uprox</i> [®]	5, 	—, PNP	10...30 VDC 200 DC, (K)
		<i>uprox</i> [®]	5, 	—, PNP	10...30 VDC 200 DC, (K)
	Q08 □ —	<i>uprox</i> [®] +	8, 	—, PNP	10...30 VDC 200 DC, (K)
		<i>uprox</i> [®] +	8, 	—, NPN	10...30 VDC 200 DC, (K)
		<i>uprox</i> [®]	5, 	—, PNP	10...30 VDC 200 DC, (K)
		<i>uprox</i> [®]	5, 	—, NPN	10...30 VDC 200 DC, (K)
		<i>uprox</i> [®] +	8, 	—, PNP	10...30 VDC 200 DC, (K)
	Q10 □ →	<i>uprox</i> [®]	8, 	—, PNP	10...30 VDC 200 DC, (K)
		<i>uprox</i> [®]	8, 	—, NPN	10...30 VDC 200 DC, (K)

型号	订货号	连接方式 (☞ 322)	开关频率 [kHz]	温度范围 [°C]	防护等级	外壳 (☞ 334)	感应面 (☞ 334)	导线 (☞ 334)	LED U _B	LED ┘
NI4U-Q8SE-AP6X-V1131	4635808 ✕	S002	1	-30...+85	IP68	PP	PP	-	-	•
NI4U-Q8SE-RP6X-V1131	4635820 ✕	S175	1	-30...+85	IP68	PP	PP	-	-	•
NI4U-Q8SE-AN6X-V1131	4635810	S005	1	-30...+85	IP68	PP	PP	-	-	•
NI4U-Q8SE-AP6X	4635807 ✕	S001	1	-30...+85	IP68	PP	PP	PUR 2 m	-	•
NI4U-Q8SE-AN6X	4635809 ✕	S004	1	-30...+85	IP68	PP	PP	PUR 2 m	-	•
BI8U-Q08-AP6X2-V1131	1662005 ✕	S002	0.25	-25...+70	IP68	GD-Zn	LCP	-	•	•
BI8U-Q08-AN6X2-V1131	1662008	S005	0.25	-25...+70	IP68	GD-Zn	LCP	-	•	•
BI5U-Q08-AP6X2-V1131	1608900 ✕	S002	0.25	-30...+85	IP67	GD-Zn	LCP	-	•	•
BI5U-Q08-AN6X2-V1131	1608910 ✕	S005	0.25	-30...+85	IP67	GD-Zn	LCP	-	•	•
BI5U-Q08-AP6X2-0,5X0R-RS4	1608925 ✕	S002	0.25	-30...+85	IP67	GD-Zn	LCP	PVC 0,5 m	•	•
BI5U-Q08-AP6X2-1X0R-RS4	1608921 ✕	S002	0.25	-30...+85	IP67	GD-Zn	LCP	PVC 1 m	•	•
BI8U-Q08-AP6X2	1662006 ✕	S001	0.25	-25...+70	IP68	GD-Zn	LCP	PUR 2 m	•	•
BI8U-Q08-AN6X2	1662007 ✕	S004	0.25	-25...+70	IP68	GD-Zn	LCP	PUR 2 m	•	•
BI5U-Q08-AP6X2	1608901 ✕	S001	0.25	-30...+85	IP67	GD-Zn	LCP	PUR 2 m	•	•
BI5U-Q08-AN6X2	1608911 ✕	S004	0.25	-30...+85	IP67	GD-Zn	LCP	PUR 2 m	•	•
BI8U-Q08-RP6X2	1662012	S054	0.25	-25...+70	IP68	GD-Zn	PA	PUR 2 m	•	•
BI8U-Q10-AP6X2	1662001 ✕	S001	0.25	-30...+85	IP67	PBT	PBT	PUR 2 m	•	•
BI8U-Q10-AN6X2	1662003	S004	0.25	-30...+85	IP67	PBT	PBT	PUR 2 m	•	•

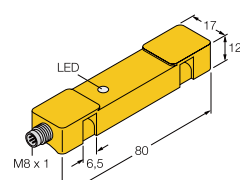
✕ = 优选型号

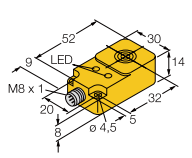
FACTOR1 *uprox*[®] / *uprox*[®]+











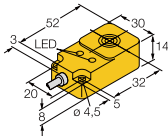



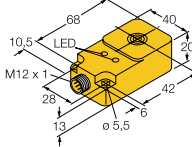



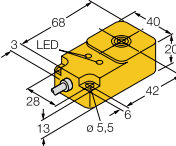

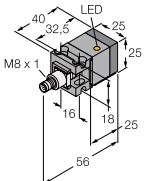

尺寸/外形	特性	额定工作 距离Sn [mm]	输出	工作电压	额定工作 电流I _e [mA]	
	Q10 	<i>uprox</i> [®] 8, 	—, PNP	10...30 VDC	200 DC, (K)	
	<i>uprox</i> [®]	8, 	—, NPN	10...30 VDC	200 DC, (K)	
	Q12 	<i>uprox</i> [®] +	—, PNP	10...30 VDC	200 DC, (K)	
	<i>uprox</i> [®] +	5, 	—, PNP	10...30 VDC	200 DC, (K)	
	<i>uprox</i> [®] +	5, 	—, NPN	10...30 VDC	200 DC, (K)	
	Q12 	<i>uprox</i> [®] +	—, PNP	10...30 VDC	200 DC, (K)	
	<i>uprox</i> [®] +	5, 	—, NPN	10...30 VDC	200 DC, (K)	
	<i>uprox</i> [®] +	5, 	—, PNP	10...30 VDC	200 DC, (K)	
	Q12 	<i>uprox</i> [®] +	—, PNP	10...30 VDC	200 DC, (K)	
	<i>uprox</i> [®] +	5, 	—, PNP	10...30 VDC	200 DC, (K)	
	<i>uprox</i> [®] +	5, 	—, NPN	10...30 VDC	200 DC, (K)	
	<i>uprox</i> [®] +	5, 	—, NPN	10...30 VDC	200 DC, (K)	
	<i>uprox</i> [®] +	5, 	—, PNP	10...30 VDC	200 DC, (K)	
	TS12 	<i>uprox</i> [®] +	—, PNP	10...30 VDC	200 DC, (K)	
	动态输出	20, 	—, NPN	10...30 VDC	200 DC, (K)	
	Q14 	<i>uprox</i> [®]	—, PNP	10...30 VDC	200 DC, (K)	
	<i>uprox</i> [®]	10, 	—, NPN	10...30 VDC	200 DC, (K)	

型号	订货号	连接方式 (☞ 322)	开关频率 [kHz]	温度范围 [°C]	防护等级	外壳 (☞ 334)	感应面 (☞ 334)	导线 (☞ 334)	LED U _B	LED └┘
BI8U-Q10-AP6X2-V1131	1662002 ✕	S002	0.25	-30...+85	IP67	PBT	PBT	-	•	•
BI8U-Q10-AN6X2-V1131	1662004	S005	0.25	-30...+85	IP67	PBT	PBT	-	•	•
BI5U-Q12-AP6X2-V1131	1635524 ✕	S002	1	-25...+70	IP68	PA	PA	-	•	•
BI5U-Q12-AP6X2-V1131/F2	1635528 ✕	S002	1	-25...+70	IP68	PA	PA	-	•	•
BI5U-Q12-AN6X2-V1131	1635525 ✕	S005	1	-25...+70	IP68	PA	PA	-	•	•
BI5U-Q12-AP6X2-H1141	1635526 ✕	S002	1	-25...+70	IP68	PA	PA	-	•	•
BI5U-Q12-AN6X2-H1141	1635527	S005	1	-25...+70	IP68	PA	PA	-	•	•
BI5U-Q12-VP6X2-H1141	1635534	S008	1	-25...+70	IP68	PA	PA	-	•	•
BI5U-Q12-AP6X2	1635522 ✕	S001	1	-25...+70	IP68	PA	PA	PUR 2 m	•	•
BI5U-Q12-VP6X2 7M	1635529	S007	1	-25...+70	IP68	PA	PA	PUR 7 m	•	•
BI5U-Q12-AN6X2	1635523	S004	1	-25...+70	IP68	PA	PA	PUR 2 m	•	•
BI5U-Q12-VN6X2 7M	1635531	S010	1	-25...+70	IP68	PA	PA	PUR 7 m	•	•
BI5U-Q12-VP6X2	1635533	S007	1	-25...+70	IP68	PA	PA	PUR 2 m	•	•
BI5U-Q12-VP6X2/F2	1635535	S007	1	-25...+70	IP68	PA	PA	PUR 2 m	•	•
NI20U-TS12-AP6X2-V1131	1646640 ✕	S002	0.008	-25...+70	IP68	PBT	-	-	•	•
NI20U-TS12-AN6X2-V1131	1625822	S005	0.008	-25...+70	IP68	PBT	-	-	•	•
BI10U-Q14-AP6X2-V1131	1608500 ✕	S002	0.25	-30...+85	IP67	PBT	PBT	-	•	•
BI10U-Q14-AN6X2-V1131	1608510 ✕	S005	0.25	-30...+85	IP67	PBT	PBT	-	•	•

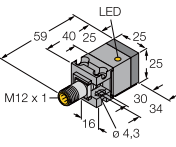
✕ = 优选型号



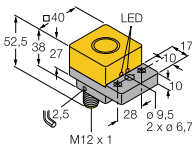









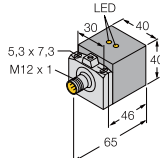

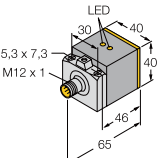









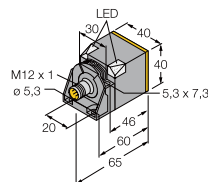

FACTOR1 *uprox*[®] / *uprox*[®]+

尺寸/外形	特性	额定工作 距离Sn [mm]	输出	工作电压	额定工作 电流Ie [mA]	
	Q14 	<i>uprox</i> [®] 10, 	—, PNP	10...30 VDC	200 DC, (K)	
	<i>uprox</i> [®] 10, 	—, NPN	10...30 VDC	200 DC, (K)		
	Q20 	<i>uprox</i> [®] 15, 	—, PNP	10...30 VDC	200 DC, (K)	
	<i>uprox</i> [®] 15, 	—, NPN	10...30 VDC	200 DC, (K)		
	Q20 	<i>uprox</i> [®] 15, 	—, PNP	10...30 VDC	200 DC, (K)	
	<i>uprox</i> [®] 15, 	—, NPN	10...30 VDC	200 DC, (K)		
	CA25 	<i>harsh</i> <i>uprox</i> [®] 10, 	—, PNP	10...30 VDC	200 DC, (K)	
	<i>harsh</i> <i>uprox</i> [®] 15, 	—, PNP	10...30 VDC	200 DC, (K)		
	CA25 	<i>harsh</i> <i>uprox</i> [®] 10, 	—, PNP	10...30 VDC	200 DC, (K)	
	<i>harsh</i> <i>uprox</i> [®] 15, 	—, PNP	10...30 VDC	200 DC, (K)		
	Q40 	<i>uprox</i> [®] +	22, 	—, PNP	10...30 VDC	200 DC, (K)

型号	订货号	连接方式 (☞ 322)	开关频率 [kHz]	温度范围 [°C]	防护等级	外壳 (☞ 334)	感应面 (☞ 334)	导线 (☞ 334)	LED U _B	LED ┘
BI10U-Q14-AP6X2	1608700 ✕	S001	0.25	-30...+85	IP67	PBT	PBT	PUR 2 m	•	•
BI10U-Q14-AN6X2	1608710 ✕	S004	0.25	-30...+85	IP67	PBT	PBT	PUR 2 m	•	•
BI15U-Q20-AP6X2-H1141	1608600 ✕	S002	0.25	-30...+85	IP67	PBT	PBT	-	•	•
BI15U-Q20-AN6X2-H1141	1608610	S005	0.25	-30...+85	IP67	PBT	PBT	-	•	•
BI15U-Q20-AP6X2	1608800 ✕	S001	0.25	-30...+85	IP67	PBT	PBT	PUR 2 m	•	•
BI15U-Q20-AN6X2	1608810 ✕	S004	0.25	-30...+85	IP67	PBT	PBT	PUR 2 m	•	•
BI10U-CA25-AP6X2-V1131	1625632 ✕	S002	0.25	-30...+85	IP67	GD-CuZn	DURO	-	•	•
NI15U-CA25-AP6X2-V1131	1625642	S002	0.25	-30...+85	IP67	GD-CuZn	DURO	-	•	•
BI10U-CA25-AP6X2-H1141	1625631 ✕	S002	0.25	-30...+85	IP67	GD-CuZn	DURO	-	•	•
NI15U-CA25-AP6X2-H1141	1625641 ✕	S002	0.25	-30...+85	IP67	GD-CuZn	DURO	-	•	•
NI22U-Q40-AP6X2-H1141	4690229 ✕	S002	0.25	0...+70	IP68	PBT	PBT	-	•	•

✕ = 优选型号

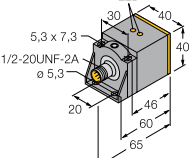









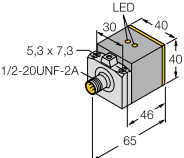



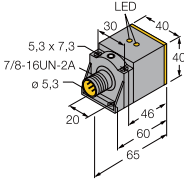



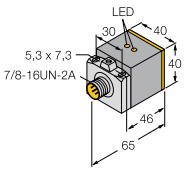

FACTOR1 *uprox*[®] / *uprox*[®]+

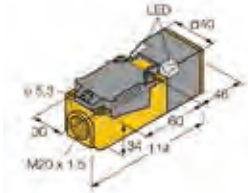
尺寸/外形	特性	额定工作 距离Sn [mm]	输出	工作电压	额定工作 电流I _e [mA]	
	CA40 □ →	20, 	—, PNP	10...30 VDC	200 DC, (K)	
	harsh <i>uprox</i> [®]	20, 	—, NPN	10...30 VDC	200 DC, (K)	
	CK40 □ →	20, 	—, PNP	10...30 VDC	200 DC, (K)	
	<i>uprox</i> [®] +	20, 	—, PNP	10...65 VDC	200 DC, (K)	
	<i>uprox</i> [®] +	20, 	—, NPN	10...30 VDC	200 DC, (K)	
	<i>uprox</i> [®] +	20, 	—, NPN	10...65 VDC	200 DC, (K)	
	<i>uprox</i> [®]	15, 	—, PNP	10...30 VDC	200 DC, (K)	
	<i>uprox</i> [®]	15, 	—, PNP	10...65 VDC	200 DC, (K)	
	<i>uprox</i> [®]	15, 	—, NPN	10...30 VDC	200 DC, (K)	
	<i>uprox</i> [®]	15, 	—, NPN	10...65 VDC	200 DC, (K)	
	<i>uprox</i> [®]	25, 	—, PNP	10...30 VDC	200 DC, (K)	
	<i>uprox</i> [®]	25, 	—, NPN	10...30 VDC	200 DC, (K)	
	CK40 □ →	30, 	—, PNP	10...30 VDC	200 DC, (K)	
	<i>uprox</i> [®] +	30, 	—, NPN	10...30 VDC	200 DC, (K)	
	<i>uprox</i> [®] +	50, 	—, PNP	10...30 VDC	200 DC, (K)	
	<i>uprox</i> [®] +	50, 	—, PNP	10...65 VDC	200 DC, (K)	
	⊕ II 3 G ⊕ II 3 D	50, 	—, PNP	10...65 VDC	200 DC, (K)	
	<i>uprox</i> [®] +	50, 	—, NPN	10...30 VDC	200 DC, (K)	
	<i>uprox</i> [®] +	50, 	—, NPN	10...65 VDC	200 DC, (K)	
	<i>uprox</i> [®]	40, 	—, PNP	10...30 VDC	200 DC, (K)	
	<i>uprox</i> [®]	35, 	—, PNP	10...30 VDC	200 DC, (K)	
	<i>uprox</i> [®]	35, 	—, NPN	10...30 VDC	200 DC, (K)	
	CK40 □ →	35, 	—	20...250 VAC 10...300 VDC	400 AC 300 DC, (K)	
	<i>uprox</i> [®]					

型号	订货号	连接方式 (☞ 322)	开关频率 [kHz]	温度范围 [°C]	防护等级	外壳 (☞ 334)	感应面 (☞ 334)	导线 (☞ 334)	LED U _B	LED ┘
BI20U-CA40-AP6X2-H1141	1627200 ✕	S002	0.25	0...+70	IP67	GD-Al	DURO	-	•	•
BI20U-CA40-AN6X2-H1141	1627300	S005	0.25	0...+70	IP67	GD-Al	DURO	-	•	•
BI20U-CK40-AP6X2-H1141	1627233 ✕	S002	0.25	-30...+85	IP68	PBT	PA-X	-	•	•
BI20U-CK40-VP4X2-H1141	1627216 ✕	S008	0.25	-30...+85	IP68	PBT	PA-X	-	•	•
BI20U-CK40-AN6X2-H1141	1627231	S005	0.25	-30...+85	IP68	PBT	PA-X	-	•	•
BI20U-CK40-VN4X2-H1141	1568814	S011	0.25	-30...+85	IP68	PBT	PA-X	-	•	•
BI15U-CK40-AP6X2-H1141	1625600 ✕	S002	0.25	-30...+85	IP68	PBT	PA-X	-	•	•
BI15U-CK40-VP4X2-H1141	1568801 ✕	S008	0.25	-30...+85	IP68	PBT	PA-X	-	•	•
BI15U-CK40-AN6X2-H1141	1625610	S005	0.25	-30...+85	IP68	PBT	PA-X	-	•	•
BI15U-CK40-VN4X2-H1141	1568811	S011	0.25	-30...+85	IP68	PBT	PA-X	-	•	•
NI25U-CK40-AP6X2-H1141	1625700 ✕	S002	0.25	-30...+85	IP68	PBT	PA-X	-	•	•
NI25U-CK40-VP4X2-H1141	1568803 ✕	S008	0.25	-30...+85	IP68	PBT	PA-X	-	•	•
NI25U-CK40-AN6X2-H1141	1625710	S005	0.25	-30...+85	IP68	PBT	PA-X	-	•	•
BI30U-CK40-AP6X2-H1141	1625829 ✕	S002	0.25	-10...+60	IP68	PBT	PA-X	-	••	••
BI30U-CK40-AN6X2-H1141	1625820	S005	0.25	-10...+60	IP68	PBT	PA-X	-	••	••
NI50U-CK40-AP6X2-H1141	1625837 ✕	S002	0.25	-30...+85	IP68	PBT	PA-X	-	••	••
NI50U-CK40-VP4X2-H1141	1538302 ✕	S008	0.25	-30...+85	IP68	PBT	PA-X	-	••	••
NI50U-CK40-VP4X2-H1141/ 3GD	1514120	S008	0.25	-30...+85	IP68	PBT	PA-X	-	••	••
NI50U-CK40-AN6X2-H1141	1625823 ✕	S005	0.25	-30...+85	IP68	PBT	PA-X	-	••	••
NI50U-CK40-VN4X2-H1141	1625806	S011	0.25	-30...+85	IP68	PBT	PA-X	-	••	••
NI40U-CK40-AP6X2-H1141	1623641 ✕	S002	0.25	-30...+85	IP68	PBT	PA-X	-	••	••
NI35U-CK40-AP6X2-H1141	1625800 ✕	S002	0.25	-30...+85	IP68	PBT	PA-X	-	••	••
NI35U-CK40-AN6X2-H1141	1625810 ✕	S005	0.25	-30...+85	IP68	PBT	PA-X	-	••	••
NI35U-CK40-ADZ30X2-B3131	4280430 ✕	S152	0.01	-30...+85	IP68	PBT	PA-X	-	•	•

✕ = 优选型号











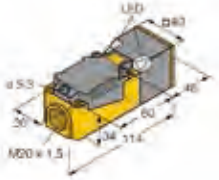















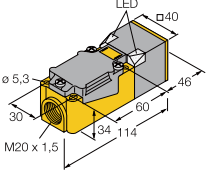

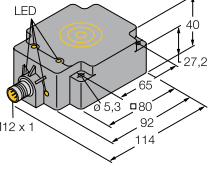

FACTOR1 *uprox*[®] / *uprox*[®]+

尺寸/外形	特性	额定工作 距离Sn [mm]	输出	工作电压	额定工作 电流I _e [mA]	
	CK40 	15, 		20...250 VAC 10...300 VDC	400 AC 300 DC, (K)	
	CK40 	35, 		20...250 VAC 10...300 VDC	400 AC 300 DC, (K)	
	CK40 	15, 		20...250 VAC 10...300 VDC	400 AC 300 DC, (K)	
	CP40 	15,  <i>uprox</i> [®] 50,  <i>uprox</i> [®] + 40,  <i>uprox</i> [®]	 , PNP  , PNP  , PNP	10...65 VDC 10...30 VDC 10...65 VDC	200 DC, (K) 200 DC, (K) 200 DC, (K)	

型号	订货号	连接方式 (☞ 322)	开关频率 [kHz]	温度范围 [°C]	防护等级	外壳 (☞ 334)	感应面 (☞ 334)	导线 (☞ 334)	LED U _B	LED ┌
BI15U-CK40-ADZ30X2-B3131	4280030 ✕	S152	0.01	-30...+85	IP68	PBT	PA-X	-	•	•
NI35U-CK40-ADZ30X2-B1131	4280410 ✕	S152	0.01	-30...+85	IP68	PBT	PA-X	-	•	•
BI15U-CK40-ADZ30X2-B1131	4280010	S152	0.01	-30...+85	IP68	PBT	PA-X	-	•	•
BI15U-CP40-VP4X2-H1141	1540502 ✕	S008	0.25	-30...+85	IP68	PBT	PA-X	-	•	•
NI50U-CP40-AP6X2-H1141	1625835 ✕	S002	0.25	-30...+85	IP68	PBT	PA-X	-	•	•
NI40U-CP40-VP4X2-H1141	1540602 ✕	S008	0.25	-30...+85	IP68	PBT	PA-X	-	•	•

✕ = 优选型号

FACTOR1 *uprox*[®] / *uprox*[®]+











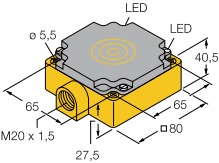







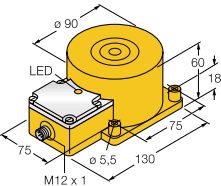



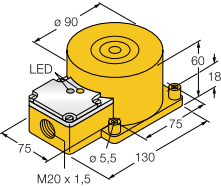

尺寸/外形	特性	额定工作 距离Sn [mm]	输出	工作电压	额定工作 电流I _e [mA]	
 <p>Dimensions for CP40: LED, Ø40, Ø5.3, 30, 60, 114, 34, M20 x 1.5</p>	CP40 	<i>uprox</i> [®] +	30, 	—, NPN	10...30 VDC	200 DC, (K)
		<i>uprox</i> [®] +	20, 	—, PNP	10...30 VDC	200 DC, (K)
		(Ex) II 3 D	20, 	—, PNP	10...30 VDC	200 DC, (K)
		<i>uprox</i> [®] +	20, 	—, NPN	10...30 VDC	200 DC, (K)
		<i>uprox</i> [®] +	20, 	—, NPN	10...65 VDC	200 DC, (K)
		<i>uprox</i> [®]	15, 	—, NPN	10...30 VDC	200 DC, (K)
		<i>uprox</i> [®]	15, 	program.	20...250 VAC 10...300 VDC	400 AC 300 DC, (K)
		<i>uprox</i> [®] +	50, 	—, PNP	10...30 VDC	200 DC, (K)
		<i>uprox</i> [®] +	50, 	—, PNP	10...65 VDC	200 DC, (K)
		<i>uprox</i> [®] +	50, 	—, NPN	10...30 VDC	200 DC, (K)
		<i>uprox</i> [®] +	50, 	—, NPN	10...65 VDC	200 DC, (K)
		<i>uprox</i> [®]	40, 	—, PNP	10...65 VDC	200 DC, (K)
		<i>uprox</i> [®]	40, 	—, NPN	10...65 VDC	200 DC, (K)
		<i>uprox</i> [®]	40, 	program.	20...250 VAC 10...300 VDC	400 AC 300 DC, (K)
 <p>Dimensions for CP40 with LED: LED, Ø40, Ø5.3, 30, 60, 114, 34, M20 x 1.5</p>	CP40 	<i>uprox</i> [®] +	30, 	—, PNP	10...30 VDC	200 DC, (K)
		<i>uprox</i> [®] +	20, 	—, PNP	10...65 VDC	200 DC, (K)
		<i>uprox</i> [®]	15, 	—, PNP	10...30 VDC	200 DC, (K)
		<i>uprox</i> [®]	15, 	—, PNP	10...65 VDC	200 DC, (K)
 <p>Dimensions for Q80: LED, 40, 27.2, 65, Ø5.3, Ø80, 92, 114, M12 x 1</p>	Q80 	<i>uprox</i> [®] +	50, 	—, PNP	10...30 VDC	200 DC, (K)
		<i>uprox</i> [®] +	50, 	—, PNP	10...65 VDC	200 DC, (K)
		(Ex) II 3 G	50, 	—, PNP	10...65 VDC	200 DC, (K)
		(Ex) II 3 D				
		<i>uprox</i> [®] +				
		<i>uprox</i> [®] +	50, 	—, NPN	10...30 VDC	200 DC, (K)
		<i>uprox</i> [®] +	50, 	—, NPN	10...65 VDC	200 DC, (K)
		<i>uprox</i> [®] +	70, 	—, PNP	10...30 VDC	200 DC, (K)
		<i>uprox</i> [®] +	70, 	—, PNP	10...65 VDC	200 DC, (K)

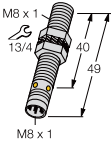
型号	订货号	连接方式 (☞ 322)	开关频率 [kHz]	温度范围 [°C]	防护等级	外壳 (☞ 334)	感应面 (☞ 334)	导线 (☞ 334)	LED	LED
									U _B	┘
BI30U-CP40-AN6X2	1625102	S006	0.25	-10...+60	IP68	PBT	PA-X	-	•	•
BI20U-CP40-AP6X2	1627232 ✘	S003	0.25	-30...+85	IP68	PBT	PA-X	-	•	•
BI20U-CP40-AP6X2/3D	1627236 ✘	S003	0.25	-20...+70	IP68	PBT	PA-X	-	•	•
BI20U-CP40-AN6X2	1627230	S006	0.25	-30...+85	IP68	PBT	PA-X	-	•	•
BI20U-CP40-VN4X2	1627237	S012	0.25	-30...+85	IP68	PBT	PA-X	-	•	•
BI15U-CP40-AN6X2	1623510	S006	0.25	-30...+85	IP68	PBT	PA-X	-	•	•
BI15U-CP40-FDZ30X2	4280600 ✘	S016	0.01	-30...+85	IP68	PBT	PA-X	-	•	•
NI50U-CP40-AP6X2	1625831 ✘	S003	0.25	-30...+85	IP68	PBT	PA-X	-	•	•
NI50U-CP40-VP4X2	1538303 ✘	S009	0.25	-30...+85	IP68	PBT	PA-X	-	•	•
NI50U-CP40-AN6X2	1625846 ✘	S006	0.25	-30...+85	IP68	PBT	PA-X	-	•	•
NI50U-CP40-VN4X2	1625847	S012	0.25	-30...+85	IP68	PBT	PA-X	-	•	•
NI40U-CP40-VP4X2	1540600 ✘	S009	0.25	-30...+85	IP68	PBT	PA-X	-	•	•
NI40U-CP40-VN4X2	1540610 ✘	S012	0.25	-30...+85	IP68	PBT	PA-X	-	•	•
NI40U-CP40-FDZ30X2	4280800 ✘	S016	0.01	-30...+85	IP68	PBT	PA-X	-	•	•
BI30U-CP40-AP6X2	1625830 ✘	S003	0.25	-10...+60	IP68	PBT	PA-X	-	••	••
BI20U-CP40-VP4X2	1627240 ✘	S009	0.25	-20...+70	IP68	PBT	PA-X	-	••	••
BI15U-CP40-AP6X2	1623500 ✘	S003	0.25	-30...+85	IP68	PBT	PA-X	-	••	••
BI15U-CP40-VP4X2	1540500 ✘	S009	0.25	-30...+85	IP68	PBT	PA-X	-	••	••
BI50U-Q80-AP6X2-H1141	1608940 ✘	S002	0.25	-25...+70	IP68	PBT	PBT	-	•	•
BI50U-Q80-VP4X2-H1141	1562000 ✘	S008	0.25	-25...+70	IP68	PBT	PBT	-	•	•
BI50U-Q80-VP4X2-H1141/3GD	1562004	S008	0.25	0...+50	IP68	PBT	PBT	-	•	•
BI50U-Q80-AN6X2-H1141	1608944	S005	0.25	-25...+70	IP68	PBT	PBT	-	•	•
BI50U-Q80-VN4X2-H1141	1562001	S011	0.25	-25...+70	IP68	PBT	PBT	-	•	•
NI70U-Q80-AP6X2-H1141	1625832 ✘	S002	0.25	-25...+70	IP68	PBT	PBT	-	•	•
NI70U-Q80-VP4X2-H1141	1625833 ✘	S008	0.25	-25...+70	IP68	PBT	PBT	-	•	•

✘ = 优选型号

3











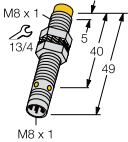





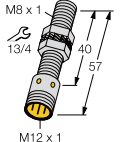







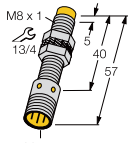





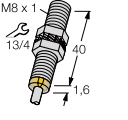



FACTOR1 *uprox*[®] / *uprox*[®]+

尺寸/外形	特性	额定工作 距离Sn [mm]	输出	工作电压	额定工作 电流Ie [mA]	
	CP80 	<i>uprox</i> [®]	75, 	—, PNP	10...30 VDC	200 DC, (K)
		<i>uprox</i> [®]	75, 	—, PNP	10...65 VDC	200 DC, (K)
		<i>uprox</i> [®]	75, 	—, PNP	10...65 VDC	200 DC, (K)
		<i>uprox</i> [®]	75, 	—, NPN	10...30 VDC	200 DC, (K)
		<i>uprox</i> [®]	75, 	—, NPN	10...65 VDC	200 DC, (K)
		<i>uprox</i> [®]	75, 	编程.	20...250 VAC 10...300 VDC	400 AC 300 DC, (K)
	K90 	<i>uprox</i> [®] +	100, 	—, PNP	10...65 VDC	200 DC, (K)
		<i>uprox</i> [®] +	100, 	—, NPN	10...65 VDC	200 DC, (K)
	K90 	<i>uprox</i> [®] +	100, 	—, PNP	10...65 VDC	200 DC, (K)
		<i>uprox</i> [®] +	100, 	—, NPN	10...65 VDC	200 DC, (K)
	M8 x 1 	<i>uprox</i> [®] +	2, 	—, PNP	10...30 VDC	150 DC, (K)
		PTFE <i>uprox</i> [®] +	2, 	—, PNP	10...30 VDC	150 DC, (K)
		<i>uprox</i> [®] +	2, 	—, PNP	10...30 VDC	150 DC, (K)
		<i>uprox</i> [®] +	2, 	—, NPN	10...30 VDC	150 DC, (K)
		<i>uprox</i> [®]	1.5, 	—, PNP	10...30 VDC	150 DC, (K)
		PTFE <i>uprox</i> [®]	1.5, 	—, PNP	10...30 VDC	150 DC, (K)
		<i>uprox</i> [®]	1.5, 	—, NPN	10...30 VDC	150 DC, (K)

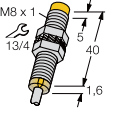
型号	订货号	连接方式 (☞ 322)	开关频率 [kHz]	温度范围 [°C]	防护等级	外壳 (☞ 334)	感应面 (☞ 334)	导线 (☞ 334)	LED U _B	LED ┘
NI75U-CP80-AP6X2	1623800 ✕	S003	0.25	-30...+85	IP67	PBT	PBT	-	•	•
NI75U-CP80-VP4X2	1540800 ✕	S009	0.25	-30...+85	IP67	PBT	PBT	-	•	•
NI75U-CP80-VP4X2-H1141	1540802	S008	0.25	-30...+85	IP67	PBT	PBT	-	•	•
NI75U-CP80-AN6X2	1623810 ✕	S006	0.25	-30...+85	IP67	PBT	PBT	-	•	•
NI75U-CP80-VN4X2	1540810 ✕	S012	0.25	-30...+85	IP67	PBT	PBT	-	•	•
NI75U-CP80-FDZ30X2	4280900 ✕	S016	0.06	-30...+85	IP67	PBT	PBT	-	•	•
NI100U-K90SR-VP4X2-H1141	1625844	S008	0.25	-30...+85	IP68	PBT	PBT	-	•	•
NI100U-K90SR-VN4X2-H1141	1515510	S011	0.25	-30...+85	IP68	PBT	PBT	-	•	•
NI100U-K90SR-VP4X2	1625834 ✕	S009	0.25	-30...+85	IP68	PBT	PBT	-	•	•
NI100U-K90SR-VN4X2	1515503 ✕	S012	0.25	-30...+85	IP68	PBT	PBT	-	•	•
BI2U-EG08-AP6X-V1131	4602033 ✕	S002	2	-30...+85	IP68	VA	PA	-	-	•
BI2U-EGT08-AP6X-V1131	4602070 ✕	S002	2	-30...+85	IP68	VA-T	PA	-	-	•
BI2U-EG08-RP6X-V1131	4602091 ✕	S175	2	-30...+85	IP68	VA	PA	-	-	•
BI2U-EG08-AN6X-V1131	4602036	S005	2	-30...+85	IP68	VA	PA	-	-	•
BI1,5U-EG08-AP6X-V1131	4600520 ✕	S002	2	-30...+85	IP68	VA	PA	-	-	•
BI1,5U-EGT08-AP6X-V1131	4600556 ✕	S002	2	-30...+85	IP67	VA-T	PA	-	-	•
BI1,5U-EG08-AN6X-V1131	4600530 ✕	S005	2	-30...+85	IP68	VA	PA	-	-	•

✕ = 优选型号











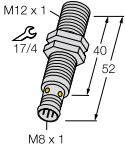





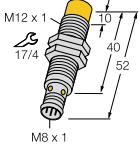





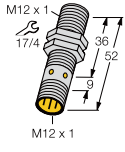





















FACTOR1 *uprox*[®] / *uprox*[®]+

尺寸/外形	特性	额定工作 距离Sn	输出	工作电压	额定工作 电流Ie	
		[mm]			[mA]	
 <p>M8 x 1</p>	<p>M8 x 1</p> 	<i>uprox</i> [®] +	6, 	—, PNP	10...30 VDC	150 DC, (K)
		<i>uprox</i> [®] +	6, 	—, PNP	10...30 VDC	150 DC, (K)
		<i>uprox</i> [®] +	6, 	—, NPN	10...30 VDC	150 DC, (K)
		<i>uprox</i> [®]	4, 	—, PNP	10...30 VDC	150 DC, (K)
		<i>uprox</i> [®]	4, 	—, NPN	10...30 VDC	150 DC, (K)
 <p>M12 x 1</p>	<p>M8 x 1</p> 	<i>uprox</i> [®] +	2, 	—, PNP	10...30 VDC	150 DC, (K)
		PTFE <i>uprox</i> [®] +	2, 	—, PNP	10...30 VDC	150 DC, (K)
		<i>uprox</i> [®] +	2, 	—, PNP	10...30 VDC	150 DC, (K)
		<i>uprox</i> [®] +	2, 	—, NPN	10...30 VDC	150 DC, (K)
		<i>uprox</i> [®]	1.5, 	—, PNP	10...30 VDC	150 DC, (K)
		PTFE <i>uprox</i> [®]	1.5, 	—, PNP	10...30 VDC	150 DC, (K)
		<i>uprox</i> [®]	1.5, 	—, NPN	10...30 VDC	150 DC, (K)
 <p>M12 x 1</p>	<p>M8 x 1</p> 	<i>uprox</i> [®] +	6, 	—, PNP	10...30 VDC	150 DC, (K)
		<i>uprox</i> [®] +	6, 	—, PNP	10...30 VDC	150 DC, (K)
		<i>uprox</i> [®] +	6, 	—, NPN	10...30 VDC	150 DC, (K)
		<i>uprox</i> [®]	4, 	—, PNP	10...30 VDC	150 DC, (K)
		<i>uprox</i> [®]	4, 	—, NPN	10...30 VDC	150 DC, (K)
 <p>M8 x 1</p>	<p>M8 x 1</p> 	<i>uprox</i> [®] +	2, 	—, PNP	10...30 VDC	150 DC, (K)
		<i>uprox</i> [®] +	2, 	—, NPN	10...30 VDC	150 DC, (K)
		<i>uprox</i> [®]	1.5, 	—, PNP	10...30 VDC	150 DC, (K)
		<i>uprox</i> [®]	1.5, 	—, PNP	10...30 VDC	150 DC, (K)
		<i>uprox</i> [®]	1.5, 	—, NPN	10...30 VDC	150 DC, (K)
		<i>uprox</i> [®]	1.5, 	—, NPN	10...30 VDC	150 DC, (K)
 <p>M8 x 1</p>	<p>M8 x 1</p> 	<i>uprox</i> [®] +	6, 	—, PNP	10...30 VDC	150 DC, (K)
		<i>uprox</i> [®] +	6, 	—, NPN	10...30 VDC	150 DC, (K)
		<i>uprox</i> [®]	4, 	—, PNP	10...30 VDC	150 DC, (K)
		<i>uprox</i> [®]	4, 	—, NPN	10...30 VDC	150 DC, (K)

型号	订货号	连接方式 (☞ 322)	开关频率 [kHz]	温度范围 [°C]	防护等级	外壳 (☞ 334)	感应面 (☞ 334)	导线 (☞ 334)	LED U _B	LED ┘
NI6U-EG08-AP6X-V1131	4635801 ✘	S002	1	-25...+70	IP68	VA	PA	-	-	•
NI6U-EG08-RP6X-V1131	4635831 ✘	S175	1	-25...+70	IP68	VA	PA	-	-	•
NI6U-EG08-AN6X-V1131	4635804	S005	1	-25...+70	IP68	VA	PA	-	-	•
NI4U-EG08-AP6X-V1131	4600620 ✘	S002	2	-30...+85	IP68	VA	PA	-	-	•
NI4U-EG08-AN6X-V1131	4600630 ✘	S005	2	-30...+85	IP68	VA	PA	-	-	•
BI2U-EG08-AP6X-H1341	4602034 ✘	S002	2	-30...+85	IP68	VA	PA	-	-	•
BI2U-EGT08-AP6X-H1341	4602071 ✘	S002	2	-30...+85	IP68	VA-T	PA	-	-	•
BI2U-EG08-RP6X-H1341	4602080 ✘	S056	2	-30...+85	IP68	VA	PA	-	-	•
BI2U-EG08-AN6X-H1341	4602037	S005	2	-30...+85	IP68	VA	PA	-	-	•
BI1,5U-EG08-AP6X-H1341	4600540 ✘	S002	2	-30...+85	IP68	VA	PA	-	-	•
BI1,5U-EGT08-AP6X-H1341	4600555 ✘	S002	2	-30...+85	IP68	VA-T	PA	-	-	•
BI1,5U-EG08-AN6X-H1341	4600550	S005	2	-30...+85	IP68	VA	PA	-	-	•
NI6U-EG08-AP6X-H1341	4635802 ✘	S002	1	-25...+70	IP68	VA	PA	-	-	•
NI6U-EG08-RP6X-H1341	4635830 ✘	S056	1	-25...+70	IP68	VA	PA	-	-	•
NI6U-EG08-AN6X-H1341	4635805	S005	1	-25...+70	IP68	VA	PA	-	-	•
NI4U-EG08-AP6X-H1341	4600640 ✘	S002	2	-30...+85	IP68	VA	PA	-	-	•
NI4U-EG08-AN6X-H1341	4600650	S005	2	-30...+85	IP68	VA	PA	-	-	•
BI2U-EG08-AP6X	4602032 ✘	S001	2	-30...+85	IP68	VA	PA	PUR 2 m	-	•
BI2U-EG08-AN6X	4602035 ✘	S004	2	-30...+85	IP68	VA	PA	PUR 2 m	-	•
BI1,5U-EG08-AP6X	4600500 ✘	S001	2	-30...+85	IP68	VA	PA	PUR 2 m	-	•
BI1,5U-EG08-AP6X 7M	4600501	S001	2	-30...+85	IP68	VA	PA	PUR 7 m	-	•
BI1,5U-EG08-AN6X	4600510 ✘	S004	2	-30...+85	IP68	VA	PA	PUR 2 m	-	•
BI1,5U-EG08-AN6X 7M	4600504	S004	2	-30...+85	IP68	VA	PA	PUR 7 m	-	•
NI6U-EG08-AP6X	4635800 ✘	S001	1	-25...+70	IP68	VA	PA	PUR 2 m	-	•
NI6U-EG08-AN6X	4635803 ✘	S004	1	-25...+70	IP68	VA	PA	PUR 2 m	-	•
NI4U-EG08-AP6X	4600600 ✘	S001	2	-30...+85	IP68	VA	PA	PUR 2 m	-	•
NI4U-EG08-AN6X	4600610 ✘	S004	2	-30...+85	IP68	VA	PA	PUR 2 m	-	•

✘ = 优选型号











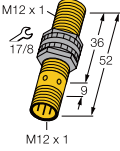









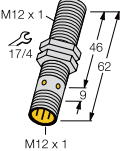

















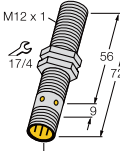

FACTOR1 *uprox*[®] / *uprox*[®]+

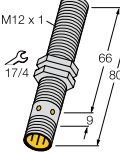
尺寸/外形	特性	额定工作 距离Sn [mm]	输出	工作电压	额定工作 电流I _e [mA]	
	M12 x 1	<i>uprox</i> [®] +	4, 	 , PNP	10...30 VDC	200 DC, (K)
		<i>uprox</i> [®] +	4, 	 , NPN	10...30 VDC	200 DC, (K)
	M12 x 1	<i>uprox</i> [®] +	10, 	 , PNP	10...30 VDC	200 DC, (K)
		<i>uprox</i> [®] +	10, 	 , NPN	10...30 VDC	200 DC, (K)
	M12 x 1	<i>uprox</i> [®] +	4, 	 , PNP	10...30 VDC	200 DC, (K)
		PTFE <i>uprox</i> [®] +	4, 	 , PNP	10...30 VDC	200 DC, (K)
		20 bar <i>uprox</i> [®] +	4, 	 , PNP	10...30 VDC	200 DC, (K)
		wash down				
		⊕ II 3 D 20 bar <i>uprox</i> [®] +	4, 	 , PNP	10...30 VDC	200 DC, (K)
		wash down				
		<i>uprox</i> [®] +	4, 	 , PNP	10...30 VDC	200 DC, (K)
		<i>uprox</i> [®] +	4, 	 , NPN	10...30 VDC	200 DC, (K)
		PTFE <i>uprox</i> [®] +	4, 	 , NPN	10...30 VDC	200 DC, (K)
		20 bar <i>uprox</i> [®] +	4, 	 , NPN	10...30 VDC	200 DC, (K)
		wash down				
		⊕ II 3 D 20 bar <i>uprox</i> [®] +	4, 	 , NPN	10...30 VDC	200 DC, (K)
		wash down				
		<i>uprox</i> [®]	3, 	 , PNP	10...30 VDC	200 DC, (K)
	PTFE <i>uprox</i> [®]	3, 	 , PNP	10...30 VDC	200 DC, (K)	
	<i>uprox</i> [®]	3, 	 , PNP	10...30 VDC	200 DC, (K)	
	<i>uprox</i> [®]	3, 	 , NPN	10...30 VDC	200 DC, (K)	
	PTFE <i>uprox</i> [®]	3, 	 , NPN	10...30 VDC	200 DC, (K)	
	<i>uprox</i> [®]	3, 	 , NPN	10...30 VDC	200 DC, (K)	

型号	订货号	连接方式 (☞ 322)	开关频率 [kHz]	温度范围 [°C]	防护等级	外壳 (☞ 334)	感应面 (☞ 334)	导线 (☞ 334)	LED U _B	LED ┘
BI4U-M12-AP6X-V1131	1634780 ✕	S002	2	-30...+85	IP68	CuZn-Cr	LCP	-	-	•
BI4U-M12-AN6X-V1131	1635430	S005	2	-30...+85	IP68	CuZn-Cr	LCP	-	-	•
NI10U-M12-AP6X-V1131	1634790 ✕	S002	2	-30...+85	IP68	CuZn-Cr	LCP	-	-	•
NI10U-M12-AN6X-V1131	1634795	S005	2	-30...+85	IP68	CuZn-Cr	LCP	-	-	•
BI4U-M12-AP6X-H1141	1634804 ✕	S002	2	-30...+85	IP68	CuZn-Cr	LCP	-	-	•
BI4U-MT12-AP6X-H1141	1634809 ✕	S002	2	-30...+85	IP68	CuZn-T	LCP	-	-	•
BI4U-EM12WD-AP6X-H1141	1634812 ✕	S002	2	-40...+100	IP68 / IP69K	VA	LCP	-	-	•
BI4U-EM12WD-AP6X-H1141/ 3D	1634851 ✕	S002	2	-40...+100	IP68 / IP69K	VA	LCP	-	-	•
BI4U-M12-RP6X-H1141	1634846 ✕	S056	2	-30...+85	IP68	CuZn-Cr	LCP	-	-	•
BI4U-M12-AN6X-H1141	1634824 ✕	S005	2	-30...+85	IP68	CuZn-Cr	LCP	-	-	•
BI4U-MT12-AN6X-H1141	1634829	S005	2	-30...+85	IP68	CuZn-T	LCP	-	-	•
BI4U-EM12WD-AN6X-H1141	1634841	S005	2	-40...+100	IP68 / IP69K	VA	LCP	-	-	•
BI4U-EM12WD-AN6X-H1141/ 3D	1634852	S005	2	-30...+85	IP68 / IP69K	VA	LCP	-	-	•
BI3U-M12-AP6X-H1141	1634140 ✕	S002	2	-30...+85	IP67	CuZn-Cr	PBT	-	-	•
BI3U-MT12-AP6X-H1141	1634240 ✕	S002	2	-30...+85	IP67	CuZn-T	PBT	-	-	•
BI3U-EM12-AP6X-H1141	1634340 ✕	S002	3	-30...+85	IP68	VA	PBT	-	-	•
BI3U-M12-AN6X-H1141	1634150 ✕	S005	2	-30...+85	IP67	CuZn-Cr	PBT	-	-	•
BI3U-MT12-AN6X-H1141	1634250 ✕	S005	2	-30...+85	IP67	CuZn-T	PBT	-	-	•
BI3U-EM12-AN6X-H1141	1634350 ✕	S005	3	-30...+85	IP68	VA	PBT	-	-	•

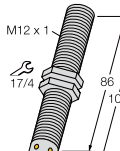
✕ = 优选型号

FACTOR1 *uprox*[®] / *uprox*[®]+











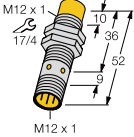











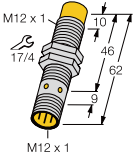

尺寸/外形	特性	额定工作 距离Sn [mm]	输出	工作电压	额定工作 电流Ie [mA]	
	M12 x 1 	<i>uprox</i> [®]	3, 	—, PNP	10...30 VDC	200 DC, 
		<i>uprox</i> [®]	3, 	—, NPN	10...30 VDC	200 DC, 
		<i>uprox</i> [®]	8, 	—, PNP	10...30 VDC	200 DC, 
		<i>uprox</i> [®]	8, 	—, NPN	10...30 VDC	200 DC, 
	M12 x 1 	<i>uprox</i> [®] +	4, 	—, PNP	10...55 VDC	200 DC, 
		20 bar <i>uprox</i> [®] +	4, 	—, PNP	10...55 VDC	200 DC, 
		wash down <i>uprox</i> [®] +	4, 	—, NPN	10...55 VDC	200 DC, 
		<i>uprox</i> [®]	3, 	—, PNP	10...65 VDC	200 DC, 
		<i>uprox</i> [®]	3, 	—, NPN	10...65 VDC	200 DC, 
		<i>uprox</i> [®]	3, 	—, NPN	10...65 VDC	200 DC, 
		<i>uprox</i> [®] +	2, 	—, 2-wire	10...65 VDC	100 DC, 
		<i>uprox</i> [®] +	2, 	—, 2-wire	10...65 VDC	100 DC, 
	M12 x 1 	<i>uprox</i> [®]	3, 	—, PNP	10...30 VDC	200 DC, 
	M12 x 1 	<i>uprox</i> [®] +	4, 	—, PNP	10...55 VDC	200 DC, 
	M12 x 1 	<i>uprox</i> [®] +	4, 	—, PNP	10...55 VDC	200 DC, 

型号	订货号	连接方式 (☞ 322)	开关频率 [kHz]	温度范围 [°C]	防护等级	外壳 (☞ 334)	感应面 (☞ 334)	导线 (☞ 334)	LED U _B	LED ┘
BI3U-S12-AP6X-H1141	1634600 ✕	S002	3	-30...+85	IP68	PBT	PBT	-	-	•
BI3U-S12-AN6X-H1141	1634620	S005	3	-30...+85	IP68	PBT	PBT	-	-	•
NI8U-S12-AP6X-H1141	1644600 ✕	S002	2	-30...+85	IP68	PBT	PBT	-	-	•
NI8U-S12-AN6X-H1141	1644620	S005	2	-30...+85	IP68	PBT	PBT	-	-	•
BI4U-M12E-VP44X-H1141	1634869 ✕	S008	2	-30...+85	IP68	CuZn-Cr	LCP	-	-	•
BI4U-EM12EWD-VP44X-H1141	1634905 ✕	S008	2	-30...+85	IP68 / IP69K	VA	LCP	-	-	•
BI4U-M12E-VN44X-H1141	1634873 ✕	S011	2	-30...+85	IP68	CuZn-Cr	LCP	-	-	•
BI3U-M12E-VP4X-H1141	1580252 ✕	S008	3	-30...+85	IP67	CuZn-Cr	PBT	-	-	•
BI3U-EM12E-VN4X-H1141	1580363	S011	3	-30...+85	IP68	VA	PBT	-	-	•
BI3U-M12E-VN4X-H1141	1580354	S011	3	-30...+85	IP67	CuZn-Cr	PBT	-	-	•
BI2U-M12E-AD4X-H1144	4405060	S99	0.01	0...+70	IP68	CuZn-Cr	LCP	-	-	•
BI2U-MT12E-AD4X-H1144	4405061	S99	0.01	0...+70	IP68	CuZn-PTFE	LCP-PTFE	-	-	•
BI3U-M12EE-AP6X-H1141	1634149 ✕	S002	3	-30...+85	IP67	CuZn-Cr	LCP	-	-	•
BI4U-M12-VP44X-H1141 L80	1634918 ✕	S008	2	-30...+85	IP68	CuZn-Cr	LCP	-	-	•
BI4U-M12-VP44X-H1141 L100	1634917 ✕	S008	2	-30...+85	IP68	CuZn-Cr	LCP	-	-	•

✕ = 优选型号

3











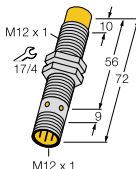



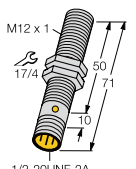



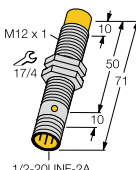



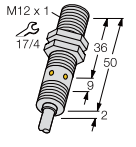





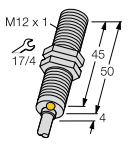













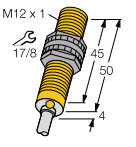

FACTOR1 *uprox*[®] / *uprox*[®]+

尺寸/外形	特性	额定工作 距离Sn [mm]	输出	工作电压	额定工作 电流I _e [mA]	
	M12 x 1 	PTFE <i>uprox</i> [®] +	10, 	—, PNP	10...30 VDC	200 DC, (K)
		20 bar <i>uprox</i> [®] +	10, 	—, PNP	10...30 VDC	200 DC, (K)
		wash down ⊗ II 3 D	10, 	—, PNP	10...30 VDC	200 DC, (K)
		20 bar <i>uprox</i> [®] +	10, 	—, PNP	10...30 VDC	200 DC, (K)
		wash down PTFE <i>uprox</i> [®] +	10, 	—, NPN	10...30 VDC	200 DC, (K)
		20 bar <i>uprox</i> [®] +	10, 	—, NPN	10...30 VDC	200 DC, (K)
		wash down ⊗ II 3 D	10, 	—, NPN	10...30 VDC	200 DC, (K)
		20 bar <i>uprox</i> [®] +	10, 	—, NPN	10...30 VDC	200 DC, (K)
		wash down <i>uprox</i> [®] +	10, 	—, PNP	10...30 VDC	200 DC, (K)
		<i>uprox</i> [®]	8, 	—, PNP	10...30 VDC	200 DC, (K)
		<i>uprox</i> [®]	8, 	—, PNP	10...30 VDC	200 DC, (K)
		PTFE <i>uprox</i> [®]	8, 	—, PNP	10...30 VDC	200 DC, (K)
		<i>uprox</i> [®]	8, 	—, NPN	10...30 VDC	200 DC, (K)
		<i>uprox</i> [®]	8, 	—, NPN	10...30 VDC	200 DC, (K)
PTFE <i>uprox</i> [®]	8, 	—, NPN	10...30 VDC	200 DC, (K)		
	M12 x 1 	<i>uprox</i> [®] +	10, 	—, PNP	10...30 VDC	200 DC, (K)
		<i>uprox</i> [®] +	10, 	—, PNP	10...55 VDC	200 DC, (K)
		20 bar <i>uprox</i> [®] +	10, 	—, PNP	10...55 VDC	200 DC, (K)
		wash down <i>uprox</i> [®] +	10, 	—, NPN	10...55 VDC	200 DC, (K)
		<i>uprox</i> [®]	8, 	—, PNP	10...65 VDC	200 DC, (K)
		<i>uprox</i> [®]	8, 	—, NPN	10...65 VDC	200 DC, (K)

型号	订货号	连接方式 (☞ 322)	开关频率 [kHz]	温度范围 [°C]	防护等级	外壳 (☞ 334)	感应面 (☞ 334)	导线 (☞ 334)	LED U _B	LED ┘
NI10U-MT12-AP6X-H1141	1634810 ✕	S002	2	-30...+85	IP68	CuZn-T	LCP	-	-	•
NI10U-EM12WD-AP6X-H1141	1634814 ✕	S002	2	-40...+100	IP68 / IP69K	VA	LCP	-	-	•
NI10U-EM12WD-AP6X-H1141/3D	1634857 ✕	S002	2	-40...+100	IP68 / IP69K	VA	LCP	-	-	•
NI10U-M12-AP6X-H1141	1634806 ✕	S002	2	-30...+85	IP68	CuZn-Cr	LCP	-	-	•
NI10U-MT12-AN6X-H1141	1634830	S005	2	-30...+85	IP68	CuZn-T	LCP	-	-	•
NI10U-EM12WD-AN6X-H1141	1634837	S005	2	-40...+100	IP68 / IP69K	VA	LCP	-	-	•
NI10U-EM12WD-AN6X-H1141/3D	1634858	S005	1	-30...+85	IP68 / IP69K	VA	LCP	-	-	•
NI10U-M12-AN6X-H1141	1634826 ✕	S005	2	-30...+85	IP68	CuZn-Cr	LCP	-	-	•
NI10U-M12-RP6X-H1141	1634848 ✕	S056	2	-30...+85	IP68	CuZn-Cr	LCP	-	-	•
NI8U-M12-AP6X-H1141	1644140 ✕	S002	2	-30...+85	IP67	CuZn-Cr	LCP	-	-	•
NI8U-EM12-AP6X-H1141	1644340 ✕	S002	2	-30...+85	IP68	VA	PBT	-	-	•
NI8U-MT12-AP6X-H1141	1644240 ✕	S002	2	-30...+85	IP67	CuZn-T	LCP	-	-	•
NI8U-M12-AN6X-H1141	1644150 ✕	S005	2	-30...+85	IP67	CuZn-Cr	LCP	-	-	•
NI8U-EM12-AN6X-H1141	1644350 ✕	S005	2	-30...+85	IP68	VA	PBT	-	-	•
NI8U-MT12-AN6X-H1141	1644250	S005	2	-30...+85	IP67	CuZn-T	PBT	-	-	•
NI10U-M12E-AP6X-H1141	1634901	S002	2	-30...+85	IP68	CuZn-Cr	LCP	-	-	•
NI10U-M12E-VP44X-H1141	1634871 ✕	S008	2	-30...+85	IP68	CuZn-Cr	LCP	-	-	•
NI10U-EM12EWD-VP44X-H1141	1634896	S008	2	-30...+85	IP68 / IP69K	VA	LCP	-	-	•
NI10U-M12E-VN44X-H1141	1634875 ✕	S011	2	-30...+85	IP68	CuZn-Cr	LCP	-	-	•
NI8U-M12E-VP4X-H1141	1580454 ✕	S008	2	-30...+85	IP67	CuZn-Cr	PBT	-	-	•
NI8U-M12E-VN4X-H1141	1580552 ✕	S011	2	-30...+85	IP67	CuZn-Cr	PBT	-	-	•

✕ = 优选型号











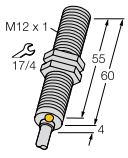



















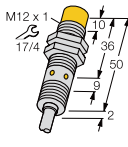







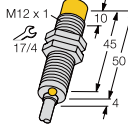















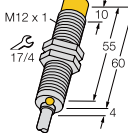













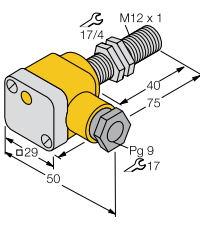













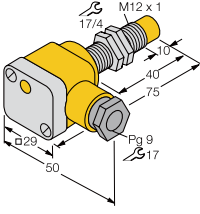

FACTOR1 *uprox*[®] / *uprox*[®]+

尺寸/外形	特性	额定工作 距离Sn [mm]	输出	工作电压	额定工作 电流Ie [mA]
 <p>M12 x 1</p>	M12 x 1 	<i>uprox</i> [®] 8, 	 , PNP	10...30 VDC	200 DC, (K)
 <p>M12 x 1 1/2-20UNF-2A</p>	M12 x 1 	<i>uprox</i> [®] 2, 		20...250 VAC 10...300 VDC	100 AC 100 DC, (K)
 <p>M12 x 1 1/2-20UNF-2A</p>	M12 x 1 	<i>uprox</i> [®] 8, 		20...250 VAC 10...300 VDC	100 AC 100 DC, (K)
 <p>M12 x 1</p>	M12 x 1 	20 bar <i>uprox</i> [®] + wash down 4,  20 bar <i>uprox</i> [®] + wash down 4, 	 , PNP  , NPN	10...30 VDC	200 DC, (K)
 <p>M12 x 1</p>	M12 x 1 	<i>uprox</i> [®] + 4,  <i>uprox</i> [®] + 4,  <i>uprox</i> [®] 3,  <i>uprox</i> [®] 3,  <i>uprox</i> [®] 3,  <i>uprox</i> [®] 3,  <i>uprox</i> [®] + 4, 	 , PNP  , NPN  , PNP  , PNP  , NPN  , NPN  , PNP	10...30 VDC	200 DC, (K)
 <p>M12 x 1</p>	M12 x 1 	<i>uprox</i> [®] 3,  <i>uprox</i> [®] 3,  <i>uprox</i> [®] 8,  <i>uprox</i> [®] 8, 	 , PNP  , NPN  , PNP  , NPN	10...30 VDC	200 DC, (K)

型号	订货号	连接方式 (☞ 322)	开关频率 [kHz]	温度范围 [°C]	防护等级	外壳 (☞ 334)	感应面 (☞ 334)	导线 (☞ 334)	LED U _B	LED ┘
NI8U-M12EE-AP6X-H1141	1644147 ✕	S002	2	-30...+85	IP67	CuZn-Cr	PA	-	-	•
BI2U-G12-ADZ32X-B3131	4281005 ✕	S019	0.02	-30...+85	IP67	CuZn-Cr	PA	-	-	•
NI8U-G12-ADZ32X-B3131	4281105 ✕	S019	0.02	-30...+85	IP67	CuZn-Cr	PA	-	-	•
BI4U-EM12WD-AP6X	1634811 ✕	S001	2	-40...+100	IP68 / IP69K	V4A (1.4404)	LCP	PP 2m	-	•
BI4U-EM12WD-AN6X	1634842	S004	2	-40...+100	IP68 / IP69K	VA	LCP	PVC 2 m	-	•
BI4U-M12-AP6X	1634803 ✕	S001	2	-30...+85	IP68	CuZn-Cr	LCP	PVC 2 m	-	•
BI4U-M12-AN6X	1634823	S004	2	-30...+85	IP68	CuZn-Cr	LCP	PVC 2 m	-	•
BI3U-M12-AP6X	1634100 ✕	S001	2	-30...+85	IP67	CuZn-Cr	PA	PVC 2 m	-	•
BI3U-EM12-AP6X	1634300 ✕	S001	3	-30...+85	IP68	VA	PBT	PVC 2 m	-	•
BI3U-M12-AN6X	1634120 ✕	S004	2	-30...+85	IP67	CuZn-Cr	PA	PVC 2 m	-	•
BI3U-EM12-AN6X	1634320	S004	3	-30...+85	IP68	VA	PBT	PVC 2 m	-	•
BI4U-M12-RP6X	1634866	S054	2	-30...+85	IP68	CuZn-Cr	LCP	PVC 2 m	-	•
BI3U-S12-AP6X	1634500 ✕	S001	3	-30...+85	IP68	PBT	PBT	PVC 2 m	-	•
BI3U-S12-AN6X	1634520	S004	3	-30...+85	IP68	PBT	PBT	PVC 2 m	-	•
NI8U-S12-AP6X	1644500 ✕	S001	2	-30...+85	IP68	PBT	PBT	PVC 2 m	-	•
NI8U-S12-AN6X	1644520	S004	2	-30...+85	IP68	PBT	PBT	PVC 2 m	-	•

✕ = 优选型号

FACTOR1 *uprox*[®] / *uprox*[®]+

尺寸/外形		特性	额定工作 距离Sn [mm]	输出	工作电压	额定工作 电流Ie [mA]
		<i>uprox</i> [®] +	4, 	 , PNP	10...55 VDC	200 DC, 
		<i>uprox</i> [®] +	4, 	 , NPN	10...55 VDC	200 DC, 
		<i>uprox</i> [®]	3, 	 , PNP	10...65 VDC	200 DC, 
		<i>uprox</i> [®]	3, 	 , NPN	10...65 VDC	200 DC, 
		<i>uprox</i> [®]	3, 	 , NPN	10...65 VDC	200 DC, 
		<i>uprox</i> [®] +	2, 	 , 2-wire	10...65 VDC	100 DC, 
		20 bar <i>uprox</i> [®] +	10, 	 , PNP	10...30 VDC	200 DC, 
		20 bar <i>uprox</i> [®] +	10, 	 , NPN	10...30 VDC	200 DC, 
		<i>uprox</i> [®] +	10, 	 , PNP	10...30 VDC	200 DC, 
		<i>uprox</i> [®] +	10, 	 , NPN	10...30 VDC	200 DC, 
		<i>uprox</i> [®]	8, 	 , PNP	10...30 VDC	200 DC, 
		<i>uprox</i> [®]	8, 	 , NPN	10...30 VDC	200 DC, 
		<i>uprox</i> [®]	8, 	 , NPN	10...30 VDC	200 DC, 
		<i>uprox</i> [®] +	10, 	 , PNP	10...55 VDC	200 DC, 
		<i>uprox</i> [®] +	10, 	 , NPN	10...55 VDC	200 DC, 
		<i>uprox</i> [®]	8, 	 , PNP	10...65 VDC	200 DC, 
		<i>uprox</i> [®]	8, 	 , NPN	10...65 VDC	200 DC, 
		<i>uprox</i> [®]	3, 	 , PNP	10...30 VDC	200 DC, 
		<i>uprox</i> [®]	3, 	 , PNP	10...65 VDC	200 DC, 
		<i>uprox</i> [®]	3, 	 , NPN	10...30 VDC	200 DC, 
		<i>uprox</i> [®]	3, 	 , NPN	10...65 VDC	200 DC, 
		<i>uprox</i> [®]	8, 	 , PNP	10...30 VDC	200 DC, 
		<i>uprox</i> [®]	8, 	 , PNP	10...65 VDC	200 DC, 
		<i>uprox</i> [®]	8, 	 , NPN	10...30 VDC	200 DC, 
		<i>uprox</i> [®]	8, 	 , NPN	10...65 VDC	200 DC, 