



Table of contents
The company
Kübler Service
Product portfolio

- Pulse Counters and Preset Counters
- Hour Meters and Timers
- Frequency Meters and Tachometers
- Combination Time and Energy Meters
- Position Displays
- Process Displays and Controllers for Temperature, Analog Signals and Strain-Gauge
- Setpoint Adjuster

Our Pulses for Innovations



The Kübler Group belongs today to the leading specialists worldwide in the fields of position and motion sensors, functional safety, counting and process technology and transmission technology.

Founded in the year 1960 by Fritz Kübler, the family business is now led by the next generation of Gebhard and Lothar Kübler.

Ten international group members and distributors in more than 50 countries offer local product know-how, service and advice throughout the world.

Innovative product and sector solutions, as well as solutions for functional safety and a high level of service, are the reasons behind our global success.

The strict focus on quality ensures the highest levels of reliability and a long service life for our products in the field.

Over 480 dedicated people worldwide make this success possible and ensure that customers can continue to place their trust in our company.



Kübler Service for worldwide Planning Reliability



24one 24one delivery promise

Manufacturing in 24 hours. For orders placed on working days before 9 AM, the product will be ready for dispatch on that same day. 24one is limited to 20 pieces per delivery.



Sample Service

We manufacture samples of special designs or according to customer specification within shortest time.



10 by 10

We will manufacture and deliver 10 encoders within 10 working days (365 days a year - with the exception of 24th Dec. until 2nd Jan.)



Safety Services

- Adapted service packages
- Individual customer solutions



48 h Express-Service

We can process your order within 48 hours; we can ship stock items the same day.



Tailor-made Solutions – Kübler Design System (KDS) OEM Products and Systems (OPS)

We develop jointly with our customers product and engineering solutions for customer-specific products, integrated drive solutions, up to complete systems.



Technical Support

Kübler' applications team is present on site all over the world for advice, analysis and support.

Kübler Germany / Austria +49 7720 3903 952
 Kübler France +33 3 89 53 45 45
 Kübler Italy +39 026 423 345
 Kübler Poland +48 61 84 99 902

Kübler Turkey +90 216 999 9791
 Kübler China +86 10 8471 0818
 Kübler India +91 2135 618200
 Kübler USA +1 855 583 2537

Our Product Portfolio

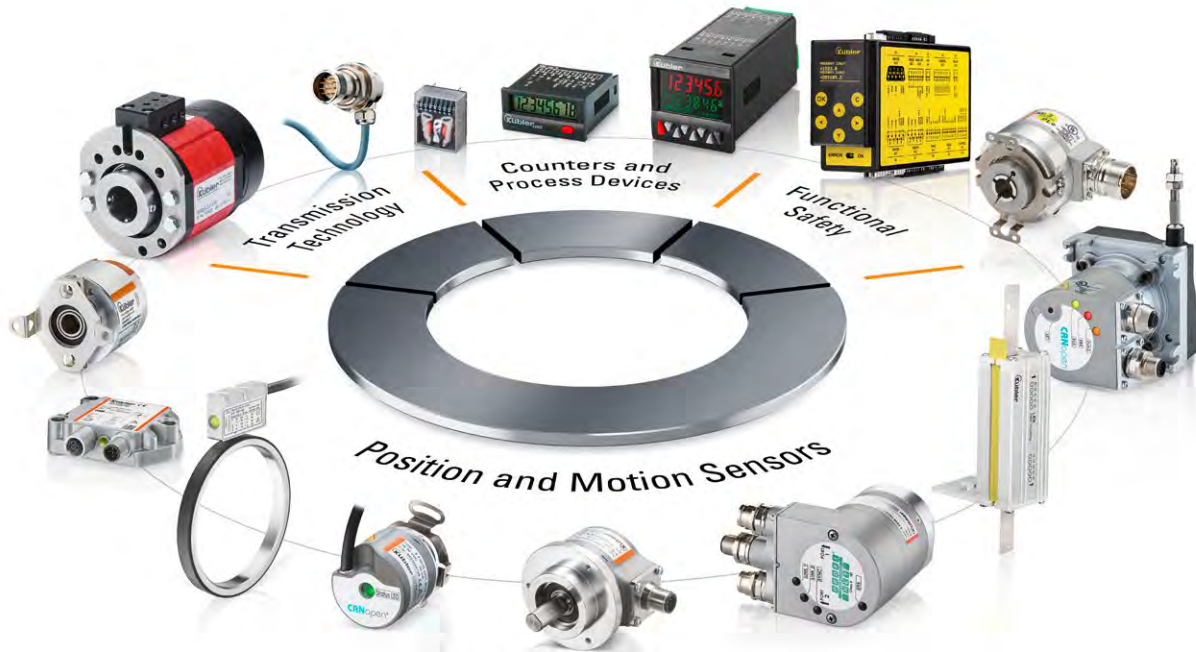

Position and Motion Sensors

- Incremental and absolute encoders
- Motor Feedback Systems
- Bearingless encoders
- Shaft copying systems
- Linear magnetic measuring systems
- Draw-wire encoders
- Inclometers
- Connection technology

Transmission Technology

- Slip rings, modular system
- Slip rings, bearingless modular system
- Slip rings, contactless transmission
- Slip rings, compact and low-maintenance
- Slip rings, Ethernet transmission
- Slip rings, High Current
- Optical fiber signal transmission modules
- Cables, connectors and pre-assembled cordsets

Functional Safety

- Certified incremental and absolute encoders
- Certified explosion-protected encoders ATEX / IECEx
- Modules for safe drive monitoring
- Safe fieldbus gateways
- Safe speed monitors
- Adapted service packages
- Connection technology

Counters and Process Devices

- Pulse counters and preset counters
- Hour meters and timers
- Frequency meters and tachometers
- Combination time and energy meters
- Position displays
- Process displays and controllers for temperature, analog signals and strain-gauge
- Setpoint adjuster

We offer Solutions for the following Industries:



The high performance level and reliability of the Kübler products are based on our long experience in these demanding application sectors. Learn more about our application-specific solutions under:

www.kuebler.com/industries

Counters and Process Devices

Product overview / Basics	5
Pulse counters	47
Preset counters	119
Hour meters / Timers	157
Frequency displays / Tachometers	217
Position displays	231
Multifunction devices	239
Energy meters	265
Process displays / Process controllers / Setpoint adjusters	269
Temperature displays / Temperature controllers	287
Strain-gauge controllers	299
Accessories / Index (List of order numbers, Addresses)	305



Product overview Basics
Pulse counters
Preset counters
Hour meters Timers
Frequency displays Tachometers
Position displays
Multifunction devices
Energy meters
Process devices
Temperature devices
Strain-gauge controllers
Accessories Index

Product overview / Basics

Product overview		Page	
Pulse counters		6	Product overview Basics
Preset counters		8	
Hour meters / Timers		10	Pulse counters
Frequency displays / Tachometers		13	
Position displays		14	Preset counters
Multifunction devices		16	
Energy meters		18	Hour meters Timers
Process displays / Process controllers / Setpoint adjusters		18	
Temperature displays / Temperature controllers		19	Frequency displays Tachometers
Strain-gauge controllers		19	
Basics		Page	
Introduction		21	Position displays
Selection criteria		22	
Mounting options		23	Energy meters
Electromechanical counters		24	
Electronic counters		29	Process devices
Process displays		37	
Interfaces		44	Temperature devices
Software		45	
			Strain-gauge controllers
			Accessories Index

Product overview

Pulse counters electronic

		Pulse	Time	Frequency	Tachometer	Position	Serial interface (SI) Fieldbus (FB)	Presets: o = optocoupler; r = relay	Reset manual	Reset electrical	Programmable	Display	Number of digits	Dimensions front in mm [inch]	Panel cut-out in mm [inch]	Depth in mm [inch]	Temperature range in °C [°F]	Protection max.	Power supply	RoHS compliant	Approvals	Page
LCD pulse counters																						
	Codix 130 adding or subtracting, AC/DC	•	-	-	-	-	-	-	•	•	-	LCD	8	48 x 24 [1.89 x 0.94]	45 x 22.2 [1.77 x 0.87]	47.7 [1.88]	-10...+60 [+14...+140]	IP65	Batt.	•	cULus	48
	Codix 131 count direction or difference counter, AC/DC	•	-	-	-	-	-	-	•	•	-	LCD	8	48 x 24 [1.89 x 0.94]	45 x 22.2 [1.77 x 0.87]	47.7 [1.88]	-10...+60 [+14...+140]	IP65	Batt.	•	cULus	51
	Codix 132 count direction, AC	•	-	-	-	-	-	-	•	•	-	LCD	8	48 x 24 [1.89 x 0.94]	45 x 22.2 [1.77 x 0.87]	47.7 [1.88]	-10...+60 [+14...+140]	IP65	Batt.	•	cULus	54
	Codix 140 adding 0...9999999	•	-	-	-	-	-	-	•	•	-	LCD	7	48 x 24 [1.89 x 0.94]	45 x 22.2 [1.77 x 0.87]	47.7 [1.88]	-20...+65 [-4...+149]	IP65	DC	•	-	57
LCD service counters																						
	Codix 142 service counter 0...9999999	•	-	-	-	-	1o	-	•	•	•	LCD	7	48 x 24 [1.89 x 0.94]	45 x 22.2 [1.77 x 0.87]	47.7 [1.88]	-20...+65 [-4...+149]	IP65	DC	•	-	57
LED pulse counters																						
	Codix 520 adding	•	-	-	-	-	-	-	•	•	•	LED	6	48 x 24 [1.89 x 0.94]	45 x 22.2 [1.77 x 0.87]	59 [2.32]	-20...+65 [-4...+149]	IP65	DC	•	cULus	60
	Codix 521 6 count modes	•	-	-	-	-	1o	-	•	•	•	LED	6	48 x 24 [1.89 x 0.94]	45 x 22.2 [1.77 x 0.87]	59 [2.32]	-20...+65 [-4...+149]	IP65	DC	•	cULus	63
	Codix 524 multifunctional	•	•	•	•	-	1o	-	•	•	•	LED	6	48 x 24 [1.89 x 0.94]	45 x 22.2 [1.77 x 0.87]	59 [2.32]	-20...+65 [-4...+149]	IP65	DC	•	cULus	240
	Codix 52U with dual functions in 4 combinations	•	•	•	•	-	-	-	•	•	•	LED	6	48 x 24 [1.89 x 0.94]	45 x 22.2 [1.77 x 0.87]	59 [2.32]	-20...+65 [-4...+149]	IP65	DC	•	cULus	250
	Codix 52P + Frequency 6 count modes	•	-	•	•	-	-	-	•	•	•	LED	6	48 x 24 [1.89 x 0.94]	45 x 22.2 [1.77 x 0.87]	59 [2.32]	-20...+65 [-4...+149]	IP65	DC	•	cULus	254
	Codix 52T / 52C 2 totalizers with separate scaling; 52C with separate inputs	•	-	-	-	-	-	-	•	•	•	LED	6	48 x 24 [1.89 x 0.94]	45 x 22.2 [1.77 x 0.87]	59 [2.32]	-20...+65 [-4...+149]	IP65	DC	•	cULus	66 / 69
	Codix 540 adding	•	-	-	-	-	-	-	•	•	•	LED	6	96 x 48 [3.78 x 1.89]	92 x 45 [3.62 x 1.77]	83 [3.27]	-20...+65 [-4...+149]	IP65	AC/DC	•	cULus	72
	Codix 541 6 count modes	•	-	-	-	-	1o	-	•	•	•	LED	6	96 x 48 [3.78 x 1.89]	92 x 45 [3.62 x 1.77]	83 [3.27]	-20...+65 [-4...+149]	IP65	AC/DC	•	cULus	75
	Codix 544 multifunctional	•	•	•	•	-	1o	-	•	•	•	LED	6	96 x 48 [3.78 x 1.89]	92 x 45 [3.62 x 1.77]	83 [3.27]	-20...+65 [-4...+149]	IP65	AC/DC	•	cULus	244
	Codix 54U with dual functions in 4 combinations	•	•	•	•	-	-	-	•	•	•	LED	6	96 x 48 [3.78 x 1.89]	92 x 45 [3.62 x 1.77]	83 [3.27]	-20...+65 [-4...+149]	IP65	AC/DC	•	cULus	258
	Codix 54P + Frequency 6 count modes	•	-	•	•	-	-	-	•	•	•	LED	6	96 x 48 [3.78 x 1.89]	92 x 45 [3.62 x 1.77]	83 [3.27]	-20...+65 [-4...+149]	IP65	AC/DC	•	cULus	261
LCD touch counter																						
	571T multifunctional (also reciprocal) analog output, serial interface	•	•	•	•	•	SI FB	4 o 2 r	•	•	•	LCD Touch	8	96 x 48 [3.78 x 1.89]	92 x 45 [3.62 x 1.77]	120 [4.72]	-20...+60 [-4...+140]	IP65	AC/DC	•	-	247
LCD modules																						
	190 PCB mounting	•	-	-	-	-	-	-	•	-	-	LCD	7	32 x 18 [1.26 x 0.71]	-	5 [0.2]	-40...+80 [-40...+176]	-	DC	•	-	78
	192 PCB mounting	•	-	-	-	-	-	-	•	-	-	LCD	6	32 x 18 [1.26 x 0.71]	-	5 [0.2]	-40...+85 [-40...+185]	-	DC	•	-	80

Product overview
Basics

Pulse counters

Preset counters

Hour meters
Timers

Frequency displays
Tachometers

Position displays

Multifunction
devices

Energy meters

Process devices

Temperature
devices

Strain-gauge
controllers

Accessories
Index

Product overview

Pulse counters electromechanical

	Pulse	Time	kWh	Panel mounting	PCB mounting	Base mounting	DIN rail mounting	Reset	Number of digits	Dimensions in mm [inch]	Panel cut-out in mm [inch] (for front panel version)	Temperature range in °C [°F]	Protection max.	Supply type	RoHS compliant	Approvals	Page
Micro counters																	
	K 46 / K 47 high shock resistance	•	-	-	•	•	-	-	6 / 7	30x20 [1.18 x 0.79] panel mount	27 x 14 [1.06 x 0.55]	-10...+60 [+14...+140]	IP65	DC	•	-	82
	K 66 / K 67 high shock resistance, magnetic field resistant	•	-	-	•	•	-	-	6 / 7	30x20 [1.18 x 0.79] panel mount	27 x 14 [1.06 x 0.55]	-10...+60 [+14...+140]	IP65	DC	•	-	85
	K 04 / K 05 high shock resistance	•	-	-	•	•	-	-	4 / 5	26x15 [1.02 x 0.59] panel mount	24 x 13 [0.94 x 0.51]	-10...+60 [+14...+140]	IP65	AC/DC	•	cULus	88
	K 06 / K 07 / AK 07 high shock resistance	•	-	-	•	•	-	-	6 / 7	32x15 [1.26 x 0.59] panel mount	30 x 13 [1.18 x 0.51]	-10...+60 [+14...+140]	IP65	AC/DC	•	cULus	88
	SK 07 high shock resistance, for DIN rail	•	-	-	-	•	•	-	7	30x65 [1.18 x 2.56]	-	-10...+60 [+14...+140]	IP50	AC/DC	•	cULus	94
Mini counters																	
	W 15 also in DIN format 48x24 mm [1.89 x 0.94"]	•	-	-	•	-	-	manual	5	from 34x23 [1.34 x 0.91]	from 31x20 [1.22 x 0.79]	-10...+50 [+14...+122]	IP40	AC/DC	•	-	96
	W 16 / W 17 also in DIN format 48x24 mm [1.89 x 0.94"]	•	-	-	•	•	-	-	6 / 7	from 34x23 [1.34 x 0.91]	from 31x20 [1.22 x 0.79]	-10...+50 [+14...+122]	IP41	AC/DC	•	-	99
Standard counters																	
	Bk 14 Very long service life	•	-	-	•	-	-	manual	4	from 37x28 [1.46 x 1.10]	from 33.3x25 [1.31 x 0.98]	-10...+60 [+14...+140]	IP40 IP41	AC/DC	•	-	102
	B 16 / B 18 Very long service life	•	-	-	•	-	• ¹⁾	manual (only B16)	6 / 8	from 50x25 [1.97 x 0.98]	50x25 [1.97 x 0.98]	-10...+60 [+14...+140]	IP40 IP41	AC/DC	•	-	104
	Mk 14 / Mk 16 Very long service life	•	-	-	•	-	-	manual electrical	4 / 6	from 37x26 [1.46 x 1.02]	from 33.3x22 [1.31 x 0.87]	-10...+45 [+14...+113]	IP40 IP41	AC/DC	•	-	110
Dual function counters																	
	HC 77 combination hour meter and totalizer	•	•	-	•	-	-	-	2x7	from 48x48 [1.89 x 1.89]	45x45 [1.77 x 2.78] ø50.5 [1.99]	-15...+50 [+5...+122]	IP65	AC/DC	•	cULus	208
	SHC 77 combination hour meter and totalizer	•	•	-	-	-	•	-	2x7	48.5x61.5 [1.91 x 2.42]	-	-15...+50 [+5...+122]	IP52	AC/DC	•	cULus	211
	HW 66 / HW 66 M combination hour meter and energy meter	-	•	•	•	-	• ¹⁾	-	2x6	from 48x48 [1.89 x 1.89]	45x45 [1.77 x 2.78] ø50 [1.97]	-20...+55 [-4...+131]	IP65	AC	•	-	266

1) With mounting frame

Product overview
Basics

Pulse counters

Preset counters

Hour meters
Timers

Frequency displays
Tachometers

Position displays

Multifunction
devices

Energy meters

Process devices

Temperature
devices

Strain-gauge
controllers

Accessories
Index

Product overview



Pulse counters pneumatic

Pneumatic counters

	Panel mounting	PCB mounting	Base mounting	DIN rail mounting	Reset	Number of digits	Panel cut-out in mm [inch] (for front panel version)	Signal	Protection max.	Count frequency max. in Hz	RoHS compliant	Page
	•	-	-	-	manual (PMk 14, PMk 16)	4/6/8	33.3x22 [1.31 x 0.87] 48x24 [1.89 x 0.94]	L signal = 1.5...8 bar O signal ≤ 0.15 bar	IP41	17 / 50	•	114

Preset counters electronic



LCD preset counters

	Pulse Time	Frequency	Tachometer	Position	Serial interface (SI) Fieldbus (FB)	Presets: o = optocoupler; r = relay	Reset manual	Reset electrical	Programmable	Display	Number of digits	Dimensions front in mm [inch]	Panel cut-out in mm [inch]	Depth in mm [inch]	Temperature range in °C [°F]	Protection max.	Power supply	RoHS compliant	Approvals	Page
	•	•	-	-	-	1r	•	•	•	LCD	2x6	48x48 [1.89 x 1.89]	45x45 [1.77 x 1.77]	63.2 [2.49]	-20...+65 [-4...+149]	IP65	batt.	•	cULus	120
	•	•	-	-	•	1r 2r	•	•	•	LCD/ LED Look	2x6	48x48 [1.89 x 1.89]	45x45 [1.77 x 1.77]	91 [3.58]	-10...+50 [+14...+122]	IP65	AC/DC	•	-	124
	•	•	•	•	-	up to 4r 6o	•	•	•	LCD/ LED Look	2x6	48x48 [1.89 x 1.89]	45x45 [1.77 x 1.77]	91 [3.58]	-20...+65 [-4...+149]	IP65	AC/DC	•	cULus	127

LCD touch preset counter

	•	•	•	•	SI FB	4o 2r	•	•	•	LCD Touch	8	96x48 [3.78 x 1.89]	92x45 [3.62 x 1.77]	120 [4.72]	-20...+60 [-4...+140]	IP65	AC/DC	•	-	247
---	---	---	---	---	----------	----------	---	---	---	--------------	---	------------------------	------------------------	---------------	--------------------------	------	-------	---	---	-----



LED preset counters

	•	•	•	•	SI FB	2r	•	•	•	LED	6	96x48 [3.78 x 1.89]	92x45 [3.62 x 1.77]	91 [3.58]	-20...+65 [-4...+149]	IP65	AC/DC	•	cULus	134
	•	-	-	-	•	4o	•	•	•	LED	6/8	96x48 [3.78 x 1.89]	92x45 [3.62 x 1.77]	141 [5.55]	0...+45 [+32...+113]	IP65	AC/DC	•	-	139
	•	-	-	-	•	4o	•	•	•	LED	6/8	96x48 [3.78 x 1.89]	92x45 [3.62 x 1.77]	141 [5.55]	0...+45 [+32...+113]	IP65	AC/DC	•	-	142

Product overview

Preset counters electromechanical

Standard counters

	Pulse	Time	Panel mounting	PCB mounting	Base mounting	DIN rail mounting	Presets	Reset	Number of digits	Dimensions in mm [inch]	Panel cut-out in mm [inch] (for front panel version)	Temperature range in °C [°F]	Protection max.	Supply type	RoHS compliant	Page
 BVa 15 adding with preset constantly visible	•	–	•	–	–	• ¹⁾²⁾	1	manual	2 x 5	from 50 x 50 [1.97 x 1.97]	50 x 50 [1.97 x 1.97]	-10...+60 [+14...+140]	IP40	AC/DC	•	145
 MVs 13 subtracting	•	–	•	–	–	–	1	manual electrical	2 / 3	from 39 x 55 [1.54 x 2.17]	33.3 x 50 [1.31 x 1.97]	-10...+45 [+14...+113]	IP40	AC/DC	•	150
 MVs 16 subtracting	•	–	•	–	–	• ¹⁾	1	manual electrical	6	from 50 x 50 [1.97 x 1.97]	50 x 50 [1.97 x 1.97]	-10...+45 [+14...+113]	IP40	AC/DC	•	154

1) With mounting frame G300003.

2) With DIN rail mount G300002.

Product overview

Hour meter Timer electronic

	Pulse	Time	Frequency	Tachometer	Position	Serial interface (SI) Fieldbus (FB)	Presets: o = optocoupler; r = relay	Reset manual	Reset electrical	Programmable	Display	Number of digits	Dimensions front in mm [inch]	Panel cut-out in mm [inch]	Depth in mm [inch]	Temperature range in °C [°F]	Protection max.	Power supply	RoHS compliant	Approvals	Page
LCD hour meters																					
	Codix 134 99999h59m or 99999.99h	-	•	-	-	-	-	•	•	-	LCD	7	48 x 24 [1.89 x 0.94]	45 x 22.2 [1.77 x 0.87]	47.7 [1.88]	-10...+60 [+14...+140]	IP65	Batt.	•	CE, UL, US	158
	Codix 135 9999h59m59s or 9999999.9s	-	•	-	-	-	-	•	•	-	LCD	8	48 x 24 [1.89 x 0.94]	45 x 22.2 [1.77 x 0.87]	47.7 [1.88]	-10...+60 [+14...+140]	IP65	Batt.	•	CE, UL, US	161
	Codix 141 99999.99h	-	•	-	-	-	-	-	•	•	-	LCD	7	48 x 24 [1.89 x 0.94]	45 x 22.2 [1.77 x 0.87]	47.7 [1.88]	-20...+65 [-4...+149]	IP65	DC	•	-
LCD service timer																					
	Codix 143 service timer 99999.99h	-	•	-	-	-	1o	•	•	•	LCD	7	48 x 24 [1.89 x 0.94]	45 x 22.2 [1.77 x 0.87]	47.7 [1.88]	-20...+65 [-4...+149]	IP65	DC	•	-	164
LED timers																					
	Codix 523 h, min, sec or hh.mm.ss	-	•	-	-	-	1o	•	•	•	LED	6	48 x 24 [1.89 x 0.94]	45 x 22.2 [1.77 x 0.87]	59 [2.32]	-20...+65 [-4...+149]	IP65	DC	•	CE, UL, US	167
	Codix 524 multifunctional	•	•	•	•	-	1o	•	•	•	LED	6	48 x 24 [1.89 x 0.94]	45 x 22.2 [1.77 x 0.87]	59 [2.32]	-20...+65 [-4...+149]	IP65	DC	•	CE, UL, US	240
	Codix 52U with dual functions in 4 combinations	•	•	•	•	-	-	-	•	•	•	LED	6	48 x 24 [1.89 x 0.94]	45 x 22.2 [1.77 x 0.87]	59 [2.32]	-20...+65 [-4...+149]	IP65	DC	•	CE, UL, US
	Codix 543 h, min, sec or hh.mm.ss	-	•	-	-	-	1o	•	•	•	LED	6	96 x 48 [3.78 x 1.89]	92 x 45 [3.62 x 1.77]	83 [3.27]	-20...+65 [-4...+149]	IP65	AC/DC	•	CE, UL, US	170
	Codix 544 multifunctional	•	•	•	•	-	1o	•	•	•	LED	6	96 x 48 [3.78 x 1.89]	92 x 45 [3.62 x 1.77]	83 [3.27]	-20...+65 [-4...+149]	IP65	AC/DC	•	CE, UL, US	244
	Codix 54U with dual functions in 4 combinations	•	•	•	•	-	-	-	•	•	•	LED	6	96 x 48 [3.78 x 1.89]	92 x 45 [3.62 x 1.77]	83 [3.27]	-20...+65 [-4...+149]	IP65	AC/DC	•	CE, UL, US
LCD time modules																					
	194 PCB mounting	-	•	-	-	-	-	•	-	-	LCD	6	32 x 18 [1.26 x 0.71]	-	5 [0.20]	-40...+80 [-40...+176]	-	DC	•	-	173
	198 PCB mounting	-	•	-	-	-	-	•	-	-	LCD	6	32 x 18 [1.26 x 0.71]	-	5 [0.20]	-40...+85 [-40...+185]	-	DC	•	-	175

Product overview
Basics

Pulse counters

Preset counters

Hour meters
Timers

Frequency displays
Tachometers

Position displays

Multifunction
devices

Energy meters

Process devices

Temperature
devices

Strain-gauge
controllers

Accessories
Index

Product overview

Hour meter Timer electromechanical

		Pulse	Time	kWh	Panel mounting	PCB mounting	Base mounting	DIN rail mounting	Reset	Number of digits	Dimensions in mm [inch]	Panel cut-out in mm [inch] (for front panel version)	Temperature range in °C [°F]	Protection max.	Supply type	RoHS compliant	Approvals	Page	
Micro timers																			
	HK 47 high shock resistance	-	•	-	•	•	-	-	-	7	30x20 [1.18 x 0.79] panel mount	27x14 [1.06 x 0.55]	-10...+60 [+14...+140]	IP66	DC	•	-	177	
	HK 07 / AHK 07 high shock and impact resistance	-	•	-	•	•	•	-	-	7	32x15 [1.26 x 0.59] panel mount	30x13 [1.18 x 0.51]	-10...+60 [+14...+140]	IP65	DC	•	-	179	
Timers with DIN dimensions																			
	HK 17 small dimensions	-	•	-	•	-	-	-	-	7 / 8	from 37x26 [1.46 x 1.02]	33x22 [1.30 x 0.87]	-15...+50 [+5...+122]	IP65	AC/DC	•		182	
	H 37 also in DIN format 48x24 mm [1.89 x 0.94"]	-	•	-	•	-	-	• ¹⁾	-	7 / 8	from 48x24 [1.89 x 0.94]	from 45x22 [1.77 x 0.87]	-15...+50 [+5...+122]	IP65	AC/DC	•		185	
	H 57 DIN format 48x48 mm [1.89 x 1.89"]	-	•	-	•	-	-	-	-	7 / 8	from 48x24 [1.89 x 0.94]	45x45 [1.77 x 1.77] ø 60 [2.36]	-15...+50 [+5...+122]	IP65	AC/DC	•		189	
Timers for DIN rail mounting																			
	AH 57 DIN format 48x48 mm [1.89 x 1.89"]	-	•	-	-	-	-	•	-	7 / 8	48.5x61.5 [1.91 x 2.40]	-	-15...+50 [+5...+122]	IP65	AC/DC	•		189	
	SHK 07.1 high shock resistance	-	•	-	-	-	-	•	-	7	30x65 [1.18 x 2.56]	-	-10...+60 [+14...+140]	IP52	AC/DC	•	-	192	
	SH 17 36 mm wide	-	•	-	-	-	-	•	-	7	36x90 [1.42 x 3.54]	-	-10...+70 [+14...+158]	IP65	AC/DC	•	-	194	
Timers, round design																			
	HR 47 opt. run indicator	-	•	-	•	-	-	-	-	7	ø 58 [2.28]	ø 50 [1.97]	-25...+80 [-13...+176]	IP65	AC/DC	•	-	196	
	HR 76 high shock resistance	-	•	-	•	-	-	-	-	6	from ø 58.7 [2.31]	ø 50.8 [2.00]	-30...+65 [-22...+149]	IP65	AC/DC	•		198	
Standard timers																			
	HB 26 plug-in version, long service life	-	•	-	•	-	-	• ¹⁾	manual	6	from 50x25 [1.97 x 0.98]	50x25 [1.97 x 0.98]	-15...+50 [+5...+122]	IP41	AC/DC	•	-	200	
	HB 27 long service life	-	•	-	•	-	-	• ¹⁾	-	7	from 50x25 [1.97 x 0.98]	50x25 [1.97 x 0.98]	-15...+50 [+5...+122]	IP51	AC/DC	•	-	204	
Dual function counters																			
	HC 77 combination hour meter and totalizer	•	•	-	•	-	-	-	-	2x7	from 48x48 [1.89 x 1.89]	45x45 [1.77 x 2.78] ø 50.5 [1.99]	-15...+50 [+5...+122]	IP65	AC/DC	•		208	
	SHC 77 combination hour meter and totalizer	•	•	-	-	-	-	•	-	2x7	48.5x61.5 [1.91 x 2.40]	-	-15...+50 [+5...+122]	IP52	AC/DC	•		211	
	HW 66 / HW 66 M combination hour meter and energy meter	-	•	•	•	-	-	• ¹⁾	-	2x6	from 48x48 [1.89 x 1.89]	45x45 [1.77 x 2.78] ø 50 [1.97]	-20...+55 [-4...+131]	IP65	AC	•	-	266	









1) With mounting frame

Product overview Basics
Pulse counters
Preset counters
Hour meters Timers
Frequency displays Tachometers
Position displays
Multifunction devices
Energy meters
Process devices
Temperature devices
Strain-gauge controllers
Accessories Index

Product overview

Time preset counters electronic

LCD time preset counters

	Pulse	Time	Frequency	Tachometer	Position	Serial interface (SI) Fieldbus (FB)	Presets: o = optocoupler; r = relay	Reset manual	Reset electrical	Programmable	Display	Number of digits	Dimensions front in mm [inch]	Panel cut-out in mm [inch]	Depth in mm [inch]	Temperature range in °C [°F]	Protection max.	Power supply	RoHS compliant	Approvals	Page
 901 1 preset – pulse, time (battery)	•	•	–	–	–	–	1r	•	•	•	LCD	2x6	48x48 [1.89 x 1.89]	45x45 [1.77 x 1.77]	63.2 [2.49]	-20...+65 [-4...+149]	IP65	Batt.	•	c  us	120
 Codix 907 / 908 multicolor display (optional), decade keyboard, count frequency 5 kHz	•	•	–	–	•	–	1r 2r	•	•	•	LCD/ LED Look	2x6	48x48 [1.89 x 1.89]	45x45 [1.77 x 1.77]	91 [3.58]	-10...+50 [+14...+122]	IP65	AC/DC	•	–	124
 Codix 923 / 924 multicolor display (optional), decade keyboard, count frequency 65 kHz	•	•	•	•	•	–	up to 4r 6o	•	•	•	LCD/ LED Look	2x6	48x48 [1.89 x 1.89]	45x45 [1.77 x 1.77]	91 [3.58]	-20...+65 [-4...+149]	IP65	AC/DC	•	c  us	127
 Codix 560 LED multifunction preset counters, 14 segment LED, automatic help texts, opt. serial interface	•	•	•	•	•	SI FB	2r	•	•	•	LED	6	96x48 [3.78 x 1.89]	92x45 [3.62 x 1.77]	91 [3.58]	-20...+65 [-4...+149]	IP65	AC/DC	•	c  us	134
 571T multifunctional (also reciprocal) analog output, serial interface	•	•	•	•	•	SI FB	4 o 2 r	•	•	•	LCD touch	8	96x48 [3.78 x 1.89]	92x45 [3.62 x 1.77]	120 [4.72]	-20...+60 [-4...+140]	IP65	AC/DC	•	–	247

Time preset counters electromechanical



Standard time preset counter

	Pulse	Time	Panel mounting	PCB mounting	Base mounting	DIN rail mounting	Presets	Reset	Number of digits	Dimensions in mm [inch]	Panel cut-out in mm [inch] (for front panel version)	Temperature range in °C [°F]	Protection max.	Supply type	RoHS compliant	Page
 HV a 15 adding	–	•	•	–	–	• ¹⁾	1	manual	2 x 5	from 50 x 50 [1.97 x 1.97]	50 x 50 [1.97 x 1.97]	-15...+50 [+5...+122]	IP42	AC/DC	•	213





1) With mounting frame G300003 or DIN rail mount G300002.

Product overview

Frequency display Tachometer

		Pulse	Time	Frequency	Tachometer	Position	Serial interface (SI) Fieldbus (FB)	Presets: o = optocoupler; r = relay	Reset manual	Reset electrical	Programmable	Display	Number of digits	Dimensions front in mm [inch]	Panel cut-out in mm [inch]	Depth in mm [inch]	Temperature range in °C [°F]	Protection max.	Power supply	RoHS compliant	Approvals	Page
LCD frequency display																						
	Codix 136 in Hz	-	-	•	•	-	-	-	-	-	-	LCD	8	48x24 [1.89 x 0.94]	45x22.2 [1.77 x 0.87]	47.7 [1.88]	-10...+60 [-4...+140]	IP65	Batt.	•	c RU US	218
LED frequency displays																						
	Codix 522 1/sec or 1/min	-	-	•	•	-	-	1o	•	•	•	LED	6	48x24 [1.89 x 0.94]	45x22.2 [1.77 x 0.87]	59 [2.32]	-20...+65 [-4...+149]	IP65	DC	•	c RU US	221
	Codix 524 multifunctional	•	•	•	•	-	-	1o	•	•	•	LED	6	48x24 [1.89 x 0.94]	45x22.2 [1.77 x 0.87]	59 [2.32]	-20...+65 [-4...+149]	IP65	DC	•	c RU US	240
	Codix 52U with dual functions in 4 combinations	•	•	•	•	-	-	-	•	•	•	LED	6	48x24 [1.89 x 0.94]	45x22.2 [1.77 x 0.87]	59 [2.32]	-20...+65 [-4...+149]	IP65	DC	•	c RU US	250
	Codix 52P + Frequency 6 count modes	•	-	•	•	-	-	-	•	•	•	LED	6	48x24 [1.89 x 0.94]	45x22.2 [1.77 x 0.87]	59 [2.32]	-20...+65 [-4...+149]	IP65	DC	•	c RU US	254
	Codix 542 1/sec or 1/min	-	-	•	•	-	-	1o	•	•	•	LED	6	96x48 [3.78 x 1.89]	92x45 [3.62 x 1.77]	83 [3.27]	-20...+65 [-4...+149]	IP65	AC/DC	•	c RU US	224
	Codix 544 multifunctional	•	•	•	•	-	-	1o	•	•	•	LED	6	96x48 [3.78 x 1.89]	92x45 [3.62 x 1.77]	83 [3.27]	-20...+65 [-4...+149]	IP65	AC/DC	•	c RU US	244
	Codix 54U with dual functions in 4 combinations	•	•	•	•	-	-	-	•	•	•	LED	6	96x48 [3.78 x 1.89]	92x45 [3.62 x 1.77]	83 [3.27]	-20...+65 [-4...+149]	IP65	AC/DC	•	c RU US	258
	Codix 54P + Frequency 6 count modes	•	-	•	•	-	-	-	•	•	•	LED	6	96x48 [3.78 x 1.89]	92x45 [3.62 x 1.77]	83 [3.27]	-20...+65 [-4...+149]	IP65	AC/DC	•	c RU US	261

Frequency displays Tachometers with limits

		Pulse	Time	Frequency	Tachometer	Position	Serial interface (SI) Fieldbus (FB)	Presets: o = optocoupler; r = relay	Reset manual	Reset electrical	Programmable	Display	Number of digits	Dimensions front in mm [inch]	Panel cut-out in mm [inch]	Depth in mm [inch]	Temperature range in °C [°F]	Protection max.	Power supply	RoHS compliant	Approvals	Page
LCD tachometer (with multicolor, LED look)																						
	Codix 923 / 924 multicolor display, decade keyboard, count frequency 65 kHz	•	•	•	•	-	-	up to 4 r 6 o	•	•	•	LCD/ LED Look	2x6	48x48 [1.89 x 1.89]	45x45 [1.77 x 1.77]	91 [3.58]	-20...+65 [-4...+149]	IP65	AC/DC	•	c RU US	127
LED tachometers with limits																						
	Codix 560 LED multifunction preset counters, 14 segment LED, automatic help texts, opt. serial interface	•	•	•	•	•	SI FB	2 r	•	•	•	LED	6	96x48 [3.78 x 1.89]	92x45 [3.62 x 1.77]	91 [3.58]	-20...+65 [-4...+149]	IP65	AC/DC	•	c RU US	134
	574 dual frequency display 4 outputs, analog output, serial interface	-	-	•	•	-	SI	4 o	•	•	•	LED	6	96x48 [3.78 x 1.89]	92x45 [3.62 x 1.77]	141 [5.55]	0...+45 [+32...+113]	IP65	AC/DC	•	-	227
LCD touch tachometers with limits																						
	571T multifunctional (also reciprocal) analog output, serial interface	•	•	•	•	•	SI FB	4 o 2 r	•	•	•	LCD touch	8	96x48 [3.78 x 1.89]	92x45 [3.62 x 1.77]	120 [4.72]	-20...+60 [-4...+140]	IP65	AC/DC	•	-	247

Product overview
Basics
Pulse counters
Preset counters
Hour meters
Timers
Frequency displays
Tachometers
Position displays
Multifunction
devices
Energy meters
Process devices
Temperature
devices
Strain-gauge
controllers
Accessories
Index

Product overview

Position displays

LCD position display



Codix 133
phase discriminator
(quadrature) x1 and x2
evaluation

Pulse	Time	Frequency	Tachometer	Position (incremental = i; SSI = s)	Serial interface (SI)	Fieldbus (FB)	Presets: o = optocoupler; r = relay	Reset manual	Reset electrical	Programmable	Display	Number of digits	Dimensions front in mm [inch]	Panel cut-out in mm [inch]	Depth in mm [inch]	Temperature range in °C [°F]	Protection max.	Power supply	RoHS compliant	Approvals	Page
-------	------	-----------	------------	-------------------------------------	-----------------------	---------------	--	--------------	------------------	--------------	---------	------------------	-------------------------------	----------------------------	--------------------	------------------------------	-----------------	--------------	----------------	-----------	------

LED position displays



Codix 521
6 count modes

Codix 524
multifunctional

Codix 52P + Frequency
6 count modes



Codix 541
6 count modes

Codix 544
multifunctional

Codix 54P + Frequency
6 count modes

LCD touch SSI position display

new





570T
SSI absolute encoder
display, analog output,
serial interface

-	-	-	-	i	-	-	-	•	•	-	LCD	8	48 x 24 [1.89 x 0.94]	45 x 22.2 [1.77 x 0.87]	47.7 [1.88]	-10...+60 [+14...+140]	IP65	Batt.	•	CE, RoHS, UL	232
•	-	-	-	i	-	1o	•	•	•	•	LED	6	48 x 24 [1.89 x 0.94]	45 x 22.2 [1.77 x 0.87]	59 [2.32]	-20...+65 [-4...+149]	IP65	DC	•	CE, RoHS, UL	63
•	•	•	•	i	-	1o	•	•	•	•	LED	6	48 x 24 [1.89 x 0.94]	45 x 22.2 [1.77 x 0.87]	59 [2.32]	-20...+65 [-4...+149]	IP65	DC	•	CE, RoHS, UL	240
•	-	•	•	i	-	-	•	•	•	•	LED	6	48 x 24 [1.89 x 0.94]	45 x 22.2 [1.77 x 0.87]	59 [2.32]	-20...+65 [-4...+149]	IP65	DC	•	CE, RoHS, UL	254
•	-	-	-	i	-	1o	•	•	•	•	LED	6	96 x 48 [3.78 x 1.89]	92 x 45 [3.62 x 1.77]	83 [3.27]	-20...+65 [-4...+149]	IP65	AC/DC	•	CE, RoHS, UL	75
•	•	•	•	i	-	1o	•	•	•	•	LED	6	96 x 48 [3.78 x 1.89]	92 x 45 [3.62 x 1.77]	83 [3.27]	-20...+65 [-4...+149]	IP65	AC/DC	•	CE, RoHS, UL	244
•	-	•	•	i	-	-	•	•	•	•	LED	6	96 x 48 [3.78 x 1.89]	92 x 45 [3.62 x 1.77]	83 [3.27]	-20...+65 [-4...+149]	IP65	AC/DC	•	CE, RoHS, UL	261
-	-	-	-	s	SI FB	4 o 2 r	•	•	•	•	LCD touch	8	96 x 48 [3.78 x 1.89]	92 x 45 [3.62 x 1.77]	120 [4.72]	-20...+60 [-4...+140]	IP65	AC/DC	•	-	235



Product overview

Position displays with limits



LCD position preset counters (optional with multicolor, LED look)

	Pulse	Time	Frequency	Tachometer	Position (incremental = i, SSI = s)	Serial interface (SI) Fieldbus (FB)	Presets: o = optocoupler; r = relay	Reset manual	Reset electrical	Programmable	Display	Number of digits	Dimensions front in mm [inch]	Panel cut-out in mm [inch]	Depth in mm [inch]	Temperature range in °C [°F]	Protection max.	Power supply	RoHS compliant	Approvals	Page
 Codix 907 / 908 multicolor display (optional), decade keyboard, count frequency 5 kHz	•	•	-	-	i	-	1r 2r	•	•	•	LCD/ LED Look	2x6	48x48 [1.89 x 1.89]	45x45 [1.77 x 1.77]	91 [3.58]	-10...+50 [+14...+122]	IP65	AC/DC	•	-	124
 Codix 923 / 924 multicolor display (optional), decade keyboard, count frequency 65 kHz	•	•	•	•	i	-	up to 4r 6o	•	•	•	LCD/ LED Look	2x6	48x48 [1.89 x 1.89]	45x45 [1.77 x 1.77]	91 [3.58]	-20...+65 [-4...+149]	IP65	AC/DC	•	UL US	127

LCD touch position preset counters

 570T SSI absolute encoder display, analog output, serial interface	-	-	-	-	s	SI FB	4o 2r	•	•	•	LCD touch	8	96x48 [3.78 x 1.89]	92x45 [3.62 x 1.77]	120 [4.72]	-20...+60 [-4...+140]	IP65	AC/DC	•	-	235
 571T multifunction (also reciprocal) analog output, serial interface	•	•	•	•	i	SI FB	4o 2r	•	•	•	LCD touch	8	96x48 [3.78 x 1.89]	92x45 [3.62 x 1.77]	120 [4.72]	-20...+60 [-4...+140]	IP65	AC/DC	•	-	247

LED position preset counters

 Codix 560 LED multifunction preset counters, 14 segment LED, automatic help texts, opt. serial interface	•	•	•	•	i	SI FB	2r	•	•	•	LED	6	96x48 [3.78 x 1.89]	92x45 [3.62 x 1.77]	91 [3.58]	-20...+65 [-4...+149]	IP65	AC/DC	•	UL US	134
 572 dual preset counters with 4 outputs and analog output, serial interface	•	-	-	-	i	SI	4o	•	•	•	LED	6/8	96x48 [3.78 x 1.89]	92x45 [3.62 x 1.77]	141 [5.55]	0...+45 [+32...+113]	IP65	AC/DC	•	-	139
 575 dual SSI display with 4 outputs and analog output, serial interface	•	-	-	-	s	SI	4o	•	•	•	LED	6/8	96x48 [3.78 x 1.89]	92x45 [3.62 x 1.77]	141 [5.55]	0...+45 [+32...+113]	IP65	AC/DC	•	-	142



Product overview

Multifunction devices electronic

LED multifunction displays

	Pulse	Time	Frequency	Tachometer	Position	Serial interface (SI) Fieldbus (FB)	Presets: o = optocoupler; r = relay	Reset manual	Reset electrical	Programmable	Display	Number of digits	Dimensions front in mm [inch]	Panel cut-out in mm [inch]	Depth in mm [inch]	Temperature range in °C [°F]	Protection max.	Power supply	RoHS compliant	Approvals	Page
 Codix 524 multifunctional	•	•	•	•	•	–	1o	•	•	•	LED	6	48 x 24 [1.89 x 0.94]	45 x 22.2 [1.77 x 0.87]	59 [2.32]	-20 ... +65 [-4 ... +149]	IP65	DC	•	CE, UL, US	240
 Codix 544 multifunctional	•	•	•	•	•	–	1o	•	•	•	LED	6	96 x 48 [3.78 x 1.89]	92 x 45 [3.62 x 1.77]	83 [3.27]	-20 ... +65 [-4 ... +149]	IP65	AC/DC	•	CE, UL, US	244

LCD multifunction preset counters

 901 1 preset – pulse, time (battery)	•	•	–	–	–	–	1r	•	•	•	LCD	2x6	48 x 48 [1.89 x 1.89]	45 x 45 [1.77 x 1.77]	63.2 [2.49]	-20 ... +65 [-4 ... +149]	IP65	Batt.	•	CE, UL, US	120
 Codix 907 / 908 multicolor display (optional), decade keyboard, count frequency 5 kHz	•	•	–	–	•	–	1r 2r	•	•	•	LCD/ LED Look	2x6	48 x 48 [1.89 x 1.89]	45 x 45 [1.77 x 1.77]	91 [3.58]	-10 ... +50 [+14 ... +122]	IP65	AC/DC	•	–	124
 Codix 923 / 924 multicolor display (optional), decade keyboard, count frequency 65 kHz	•	•	•	•	•	–	up to 4r 6o	•	•	•	LCD/ LED Look	2x6	48 x 48 [1.89 x 1.89]	45 x 45 [1.77 x 1.77]	91 [3.58]	-20 ... +65 [-4 ... +149]	IP65	AC/DC	•	CE, UL, US	127



LED multifunction preset counters

 Codix 560 LED multifunction preset counters, 14 segment LED, automatic help texts, opt. serial interface	•	•	•	•	•	SI FB	2r	•	•	•	LED	6	96 x 48 [3.78 x 1.89]	92 x 45 [3.62 x 1.77]	91 [3.58]	-20 ... +65 [-4 ... +149]	IP65	AC/DC	•	CE, UL, US	134
--	---	---	---	---	---	----------	----	---	---	---	-----	---	--------------------------	--------------------------	--------------	------------------------------	------	-------	---	------------	-----

LCD touch multifunction preset counter

 571T multifunctional (also reciprocal) analog output, serial interface	•	•	•	•	•	SI FB	4o 2r	•	•	•	LCD touch	8	96 x 48 [3.78 x 1.89]	92 x 45 [3.62 x 1.77]	120 [4.72]	-20 ... +60 [-4 ... +140]	IP65	AC/DC	•	–	247
--	---	---	---	---	---	----------	----------	---	---	---	--------------	---	--------------------------	--------------------------	---------------	------------------------------	------	-------	---	---	-----





LED dual function displays

 Codix 52U with dual functions in 4 combinations	•	•	•	•	–	–	–	•	•	•	LED	6	48 x 24 [1.89 x 0.94]	45 x 22.2 [1.77 x 0.87]	59 [2.32]	-20 ... +65 [-4 ... +149]	IP65	DC	•	CE, UL, US	250
Codix 52P + Frequency 6 count modes	•	–	•	•	•	–	–	•	•	•	LED	6	48 x 24 [1.89 x 0.94]	45 x 22.2 [1.77 x 0.87]	59 [2.32]	-20 ... +65 [-4 ... +149]	IP65	DC	•	CE, UL, US	254
Codix 52T 2 counters with separate scaling	•	–	–	–	–	–	–	•	•	•	LED	6	48 x 24 [1.89 x 0.94]	45 x 22.2 [1.77 x 0.87]	59 [2.32]	-20 ... +65 [-4 ... +149]	IP65	DC	•	CE, UL, US	66
Codix 52C 2 counters with separate inputs and separate scaling	•	–	–	–	–	–	–	•	•	•	LED	6	48 x 24 [1.89 x 0.94]	45 x 22.2 [1.77 x 0.87]	59 [2.32]	-20 ... +65 [-4 ... +149]	IP65	DC	•	CE, UL, US	69
 Codix 54U with dual functions in 4 combinations	•	•	•	•	–	–	–	•	•	•	LED	6	96 x 48 [3.78 x 1.89]	92 x 45 [3.62 x 1.77]	83 [3.27]	-20 ... +65 [-4 ... +149]	IP65	AC/DC	•	CE, UL, US	258
Codix 54P + Frequency 6 count modes	•	–	•	•	•	–	–	•	•	•	LED	6	96 x 48 [3.78 x 1.89]	92 x 45 [3.62 x 1.77]	83 [3.27]	-20 ... +65 [-4 ... +149]	IP65	AC/DC	•	CE, UL, US	261

Product overview

Multifunction devices electromechanical

Dual function counters

	Pulse	Time	kWh	Panel mounting	PCB mounting	Base mounting	DIN rail mounting	Reset	Number of digits	Dimensions in mm [inch]	Panel cut-out in mm [inch] (for front panel version)	Temperature range in °C [°F]	Protection max.	Supply type	RoHS compliant	Approvals	Page
	•	•	–	•	–	–	–	–	2x7	from 48x48 [1.89 x 1.89]	45x45 [1.77 x 1.77] ø 50.5 [1.99]	- 15 ... + 50 [+5 ... +122]	IP65	AC/DC	•		208
	•	•	–	–	–	–	•	–	2x7	48.5x61.5 [1.91 x 2.42]	–	- 15 ... + 50 [+5 ... +122]	IP52	AC/DC	•		211
	–	•	•	•	–	–	• 1)	–	2x6	from 48x48 [1.89 x 1.89]	45x45 [1.77 x 1.77] ø 50 [1.97]	- 20 ... + 55 [-4 ... +131]	IP65	AC	•	–	266

1) With mounting frame

Product overview Basics
Pulse counters
Preset counters
Hour meters Timers
Frequency displays Tachometers
Position displays
Multifunction devices
Energy meters
Process devices
Temperature devices
Strain-gauge controllers
Accessories Index

Product overview



Energy meters

Dual function counter

	Pulse	Time	kWh	Panel mounting	PCB mounting	Base mounting	DIN rail mounting	Reset	Number of digits	Dimensions in mm [inch]	Panel cut-out in mm [inch] (for front panel version)	Temperature range in °C [°F]	Protection max.	Supply type	RoHS compliant	Approvals	Page
	-	•	•	•	-	-	• ²⁾	-	2x6	from 48x48 [1.89 x 1.89]	45x45 [1.77 x 1.77] ø 50 [1.97]	-20...+55 [-4...+131]	IP65	AC	•	-	266

Process displays Process controllers Setpoint adjusters

LED process displays

	Standard signal 0...20; 4...20 mA	Standard signal 0...10; 2...10V	Standard signal ± 10V	Serial interface (SI) Fieldbus (FB)	Input characteristic curve	Presets/Limit values	Analog output	Display	Number of digits	Dimensions front in mm [inch]	Depth in mm [inch]	Temperature range in °C [°F]	Protection max.	Power supply	RoHS compliant	Approvals	Page
new 	•	•	-	-	linear	-	-	LED	5	48x24 [1.89 x 0.94]	59 [2.32]	-10...+50 [+14...+122]	IP65	DC	•	UL US	270
	•	•	•	-	12 S	2r	•	LED	6	96x48 [3.78 x 1.89]	90.5 [3.56]	-20...+65 [-4...+149]	IP65	AC/DC	•	UL US	273

LED process controller

	•	•	•	-	12 S	2r	•	LED	6	96x48 [3.78 x 1.89]	90.5 [3.56]	-20...+65 [-4...+149]	IP65	AC/DC	•	UL US	273
---	---	---	---	---	------	----	---	-----	---	------------------------	----------------	--------------------------	------	-------	---	-------	-----

LCD touch process controller

new 	•	•	•	SS FB	24 S	4 o 2 r	•	LCD touch	8	96x48 [3.78 x 1.89]	120 [4.72]	-20...+60 [-4...+140]	IP65	AC/DC	•	-	277
--	---	---	---	----------	------	------------	---	--------------	---	------------------------	---------------	--------------------------	------	-------	---	---	-----







LED setpoint adjuster

	-	-	-	-	-	-	•	LED	4	48x24 [1.89 x 0.94]	59 [2.32]	-20...+65 [-4...+149]	IP65	DC	•	UL US	281
---	---	---	---	---	---	---	---	-----	---	------------------------	--------------	--------------------------	------	----	---	-------	-----

Product overview

Temperature displays Temperature controllers

LED temperature displays



	Temperature Thermocouples	Temperature Resistance thermometers (RTDs)	mV/V sensors / strain gauge input	Input characteristic curve S = control points	Presets/Limit values o = optocoupler; r = relay	Analog output	Display	Number of digits	Dimensions front in mm [inch]	Depth in mm [inch]	Temperature range in °C [°F]	Protection max.	Power supply	RoHS compliant	Approvals	Page
	Codix 531 Min / Max value detection	Pt100 Ni100	-	-	-	-	LED	5	48x24 [1.89 ... 0.94]	59 [2.32]	-20...+65 [-4...+149]	IP65	DC	• c 	288	
	Codix 532 Min / Max value detection	-	J; K; N	-	-	-	LED	5	48x24 [1.89 ... 0.94]	59 [2.32]	-20...+65 [-4...+149]	IP65	DC	• c 	291	
	Codix 564 Min / Max value detection, 2 limit values, analog output	Pt100 0...500 Ω	B; E; J; K; N; R; S; T	±100 mV	12 S	2r	• LED	6	96x48 [3.78 ... 1.89]	90.5 [3.56]	-20...+65 [-4...+149]	IP65	AC/DC	• c 	294	

LED temperature controller

	Codix 564 Min / Max value detection, 2 limit values, analog output	Pt100 0...500 Ω	B; E; J; K; N; R; S; T	±100 mV	12 S	2r	• LED	6	96x48 [3.78 ... 1.89]	90.5 [3.56]	-20...+65 [-4...+149]	IP65	AC/DC	• c 	294
--	--	--------------------	------------------------------	------------	------	----	-------	---	--------------------------	----------------	--------------------------	------	-------	---	-----







Strain-gauge controllers

LED strain-gauge controller

	mV/V sensors / strain gauge input	Input characteristic curve S = control points	Presets/Limit values o = optocoupler; r = relay	Analog output	Display	Number of digits	Dimensions front in mm [inch]	Depth in mm [inch]	Temperature range in °C [°F]	Protection max.	Power supply	RoHS compliant	Approvals	Page
	Codix 566 Min / Max value detection, 2 limit values with totalizer, tare, analog output	12 S	2r	•	LED	6	96x48 [3.78 ... 1.89]	90.5 [3.56]	-20...+65 [-4...+149]	IP65	AC/DC	• c 	300	

Product overview Basics
Pulse counters
Preset counters
Hour meters Timers
Frequency displays Tachometers
Position displays
Multifunction devices
Energy meters
Process devices
Temperature devices
Strain-gauge controllers
Accessories Index

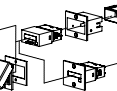
Product overview

		Page overview	Page details
Accessories			
	Adapter front bezel	306	312
	Sealing cover	307	315
	Transparent cover	307	316
	Front bezel	308	318
	Socket boxes	308	319
	Mounting examples	309	–
	Mounting frame	310	321
	DIN rail mount	310	322
	Enclosure blind	311	323
	Other accessories	311	324
	Gaskets	–	331

Product overview
Basics

Pulse counters

Preset counters

Hour meters
Timers

Frequency displays
Tachometers

Position displays

Multifunction
devices

Energy meters

Process devices

Temperature
devices

Strain-gauge
controllers

Accessories
Index

Counters / Process devices Introduction

Counters / Process devices

Counting technology

Electromechanical counters in many versions, as well as miniature counters for PCB-mounting (our special area of competence), are ideal time and pulse counters for pumps, lifts, dryers, UV lamps, KWh meters and much more.

The Codix series offers functional, low-cost electronic display counters, position displays, timers and tachometers. Our electronic multifunction preset counters enable decentralised control and so reduce cycle times.

Process technology

The user-friendly, compact and functionally well thought through Codix process displays and controllers are ideal for all linear and non-linear analog signals.

Together with our temperature displays and controllers, as well as our strain-gauge controllers and setpoint adjuster, they are used in a wide variety of applications.

Application examples

Roller shutter door with automatic shut-off

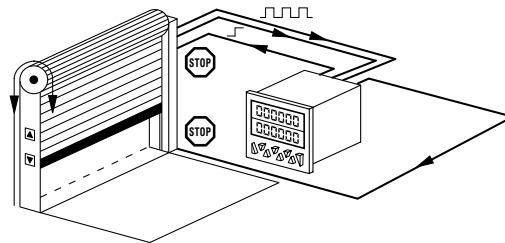

Interval measurement

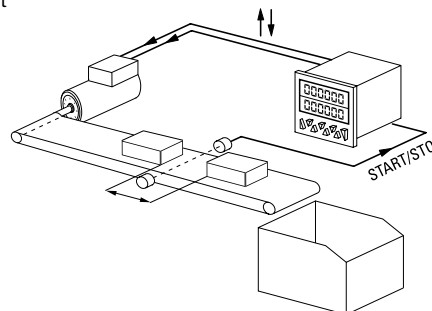

Time-controlled production line

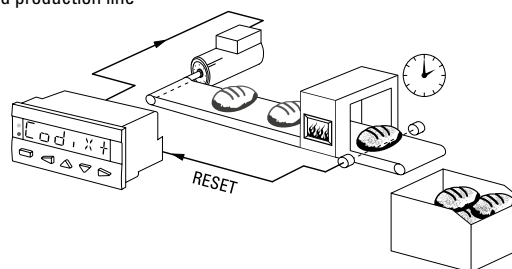

Cut-to-length with overall total count and control of the machine

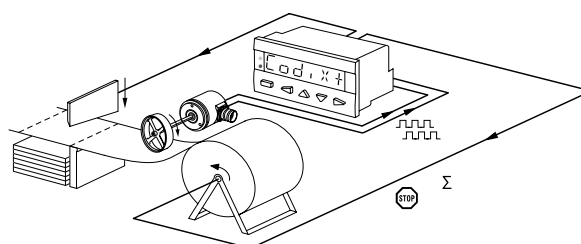

Product overview
Basics

Pulse counters

Preset counters

Hour meters
Timers

Frequency displays
Tachometers

Position displays

Multifunction
devices

Energy meters

Process devices

Temperature
devices





Strain-gauge
controllers

Accessories
Index

Counters / Process devices Selection criteria

Conformity All counters and process devices carry the CE mark and are tested for electromagnetic compatibility and immunity to interference. The counters and process devices meet the requirements according to EN 61000-6-2, EN 61000-6-4, EN 61000-6-3 and EN 55011 (For details see the data sheets).

Safety Designed to EN 61010 part 1
Protection class 2
Application area pollution level 2

Approvals Many of our products are UL (Underwriters Laboratories Inc.) approved.  
Products in Ex proof version acc. to explosion-proof class EEX D IIC T6 or zone 2/22 on request. 
Kübler is active worldwide and has made a company commitment to protecting the environment. Our product range is RoHS compliant. 

Special versions / Options These are modifications of standard versions. The most common versions available are listed under the various type series (further options on request).

Temperature *Working temperature:* Temperature range of the environment, in which the device complies with the specifications shown in the data sheet. *Operating temperature:* Temperature range of the environment, in which the device can be operated, without suffering damage.

Soiling and humidity The IP classification according to EN 60529 describes how the encoder is protected against particles and water. It is described as an abbreviation "IP" followed by two numbers. The tables show an overview of the common types of IP protection.

Protection against particles (first digit)
The higher the number, the smaller the particles.

0	Not protected
1	Protected against particles \varnothing 50 mm and larger
2	Protected against particles \varnothing 12.5 mm and larger
3	Protected against particles \varnothing 2.5 mm and larger
4	Protected against particles \varnothing 1.0 mm and larger
5	Protected against dust
6	Dust proof

Protection against water (second digit)
The higher the number, the higher the water pressure can be.

0	Not protected
1	Protected against vertically falling drops of water
2	Protected against vertically falling drops of water when enclosure is tilted up to 15°
3	Protected against spraying water
4	Protected against splashing water
5	Protected against water jets
6	Protected against powerful water jets
7	Protected against the effects of temporary immersion in water
8	Protected against the effects of continuous immersion in water

Kübler devices are available with a protection level up to IP66.

Product overview
Basics

Pulse counters

Preset counters

Hour meters
Timers

Frequency displays
Tachometers

Position displays

Multifunction
devices





Energy meters

Process devices

Temperature
devices

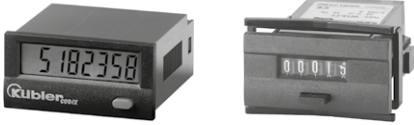
Strain-gauge
controllers

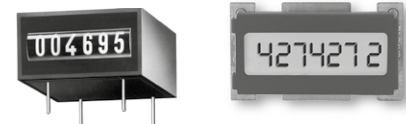
Accessories
Index

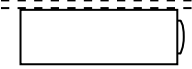
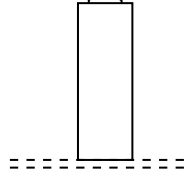
Counters / Process devices	Mounting options	Product overview Basics
Panel mount	<ul style="list-style-type: none"> • Mounting in front panel cut-outs, control cabinet doors, housings etc. • Display on the front side • Various mounting options by means of a variety of front bezel adapters • Gaskets for increased protection levels available as accessories • Panel mounting offers protection of the connections 	Pulse counters
		Preset counters
Base mount	<ul style="list-style-type: none"> • Fixing onto the mounting plate • Display on the front side • High mechanical strength • Connections above the mounting plate 	Hour meters Timers
		Frequency displays Tachometers
DIN-rail mounting	<ul style="list-style-type: none"> • Snap-on mounting on DIN-rail for counters with integrated DIN-rail fixing • Panel mount counters can be mounted via DIN-rail adapter, plug-in counters via DIN-rail socket • Display on the front side 	Position displays
		Multifunction devices
PCB mounting	<ul style="list-style-type: none"> • Fixing via solder pins direct onto the PCB board, upright or lying • Flexible location of the display • Washable versions with high protection level • High temperature ranges – also suitable for machine soldering 	Energy meters
		Process devices
		Temperature devices
		Strain-gauge controllers
		Accessories Index

Electromechanical counters Versions

Overview

Electromechanical counters are divided into:

- **Pulse counters**
- **Preset counters**
- **Hour meters / Timers**
- **Time preset counters**

The counter construction consists of an electromagnetic drive and a mechanical number wheel system. Electrical impulses cause a step-by-step advance of the number wheels.

Totalizing counters add the incoming pulses. They are manufactured without reset, with reset key (button) or with electrical reset. Smaller design counters are also available for battery operation with a low power consumption of 30 or 50 mW, and offer high shock and vibration resistance.

Product overview
Basics

Pulse counters

Preset counters

Pulse counters

These counters have no outputs activated at a specific count value. They are used purely to monitor the count value.

The function of the counters lies primarily in simple totalizing of the incoming pulses.

Example:

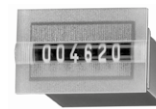

K 47



W 15

Hour meters
Timers

Frequency displays
Tachometers

Preset counters

The purpose of preset counters is to trigger a signal at a particular count value. In the simplest instance this can mean just shutting down a machine, however it could also be the initialisation of control functions (e.g. cutting material to length, transporting parts etc.).

The outputs are suitable for switching large loads. The actual switching capacity depends on the model (counter) and can be seen in the data sheet. With most contacts a changeover function is available.

Example:



BVa 15

Position displays

Multifunction
devices

Adding

The counter starts from zero and counts up to the programmed preset value, at which an output signal is triggered. The counter is then reset to zero - this can be programmed to happen automatically. The current count value is always displayed.

Subtracting

The counter starts from the preset value or from a separate setpoint and counts down to zero, at which an output signal is triggered. The counter is then reset to the preset value. The value displayed corresponds to the difference between the preset value and the count value.

Energy meters

Hour meters / Timers

Timers measure the time in the unit of time, for which the device is laid out. With the electromechanical counters this time is displayed in hours with one or two decimal places.

Timing starts when the supply voltage is applied to the timer.

The time base is hours with either 1/10 or 1/100 h resolution (1/100 hours = 36 seconds)

Example:



H 57



H 37

Process devices

Temperature
devices

Time preset counters

Preset timers measure the time in the unit of time, for which the device is laid out. With the electromechanical counters this time is displayed in hours with one or two decimal places.

Timing starts when the supply voltage is applied to the timer.

The respective output is activated, as soon as the preset value is reached.

Example:



HVa 15

Strain-gauge
controllers

Accessories
Index

Electromechanical counters		Basic technical information		Product overview Basics
Current type	Our counters are all constructed for DC voltage. On AC voltages a rectifier is always required.	The maximum permissible voltage fluctuation for DC and AC is generally $\pm 10\%$ of the nominal voltage at maximum count frequencies.		Pulse counters
Residual ripple	Is the AC voltage superposed on the DC voltage in % $\frac{U_w}{U_g} \times 100\%$	U_w = Effective value of superposed AC voltage U_g = Arithmetical mean value of DC voltage		Preset counters
Power consumption	Is the power in W or VA that a pulse counter consumes at continuous pulse and rated voltage with unheated coil (20°C).			Hour meters Timers
Maximum pulse frequency	Is the maximum possible count frequency which the counter in question can consume in permanent operation.	It differs according to counter type and power consumption and is limited by the required pickup- and release times of the counting solenoid.		Frequency displays Tachometers
Minimum pulse on time	Is the period of time which is sufficient for accurate counting, even at permissible \pm variation of operating voltage; the pulse interval can be optionally as long as required.			Position displays
Minimum pulse interval	Is the period of time which is sufficient for accurate counting.	Optimal spark quenching is imperative if high count frequency is required.		Multifunction devices
Pulse ratio	Is the ratio of $\frac{\text{pulse on time}}{\text{pulse interval}}$ at maximum count frequency			Energy meters
On time ED	States how long a coil may be energized without overheating. For the on time the following formula applies: $\text{ED \%} = \frac{\text{pulse on time}}{\text{pulse on time} + \text{pulse interval}} \times 100$ From this can be derived: $\text{pulse on time} = \frac{\text{ED \%}}{100 - \text{ED \%}} \times \text{pulse interval}$ $\text{pulse interval} = \frac{100 - \text{ED \%}}{\text{ED \%}} \times \text{pulse on time}$ <i>Example:</i> A count coil has the listed value ED = 15 %, max. 55 sec. This coil may therefore remain under constant current for max. 55 sec. After this a cooling interval of $\text{pulse interval} = \frac{100 - 15}{15} \times 55 \text{ sec} = 283 \text{ sec}$ <i>Result:</i> Since the on time does not exceed 15 % these pulse-on times are permissible.	In addition to the ED % figure the listed values include an addition concerning the maximum permanent on time. Therefore a coil may only be energized by a constant current during this period and then has to be cooled off again. At ED = 100% a limitation is not necessary as the coil will never become inadmissibly hot, even if continuously energized. The same coil is constantly receiving pulses of 40 sec. duration with a count interval of 6 min. Is this still permissible? $\text{ED \%} = \frac{40}{40 + 360} \times 100 = 10\%$	Process devices Temperature devices	
Operating temperature	Is the permissible temperature within the direct vicinity of the pulse counter.	When using the counters in groups, the reciprocal heating must be taken into consideration as this results in an operating temperature rise. The upper or lower value is only applicable to the rated voltage.		Strain-gauge controllers

Electromechanical counters

Basic technical information

Instructions for electromechanical pulse counters

DC voltage pulses without or with very small residual ripple are, for example, taken from a battery, DC generator, electronically stabilised power supply, according to the circuit above. These pulses are most suitable for the maximum possible frequencies due to their ideal square wave shape. If only AC voltage is available it must be rectified. Therefore, according to count speed, a more or less greater degree of residual ripple has to be put up with. A simple bridge-rectifier will give a residual ripple of approx. 48%, and the following relationship is applicable:

Pulse voltage

AC voltage (effective value)

12	24	48	60	110	220 V
----	----	----	----	-----	-------

DC voltage (arithm. mean value)

8.5	19.5	40	49	91	185 V
-----	------	----	----	----	-------

Pulse voltages (at count coil)

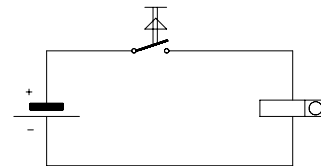
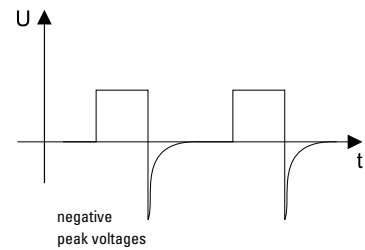

Two types of switching circuits can be used to drive the counters

a) Pulse contact in AC circuit model a0 or a

This circuit is mostly used when the count speed is ≤ 18 Hz

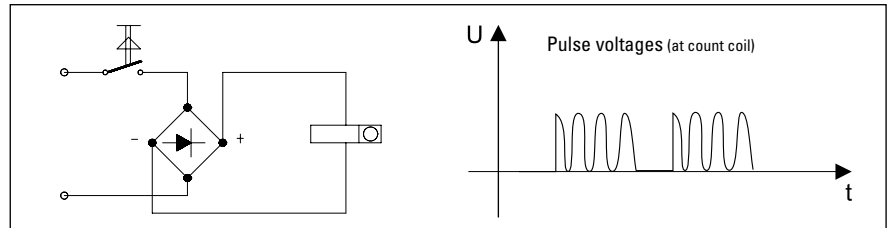

Advantage:

No spark required; contact bounces have no negative effect because the rectifier acts as spark quenching and provides inductive drop-out time lag.

Disadvantages:

Count speed only possible up to max. 18 Hz

b) Pulse contact in DC circuit model 05, 0, 1

With high pulse speeds smoothed DC must be used. The residual ripple (smoothing degree) is determined by the count speed and is stated in the technical specification.

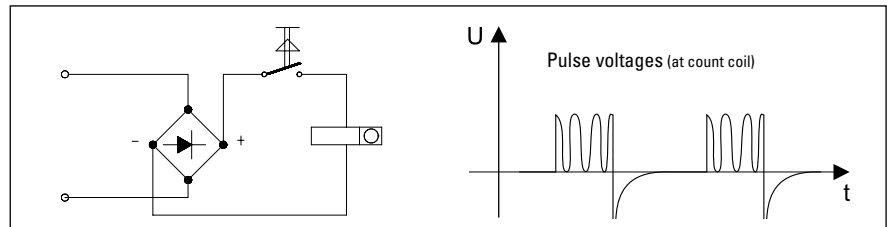

Advantages:

High count speed up to max. 25 Hz.
Only one rectifier is necessary when driving several counters.

Disadvantages:

More sensitive to contact bounce, spark quenching is required. 4 connection points required if rectifier is built into counter.

Electromechanical counters Basic technical information

Simple bridge circuit smoothing by capacitor:

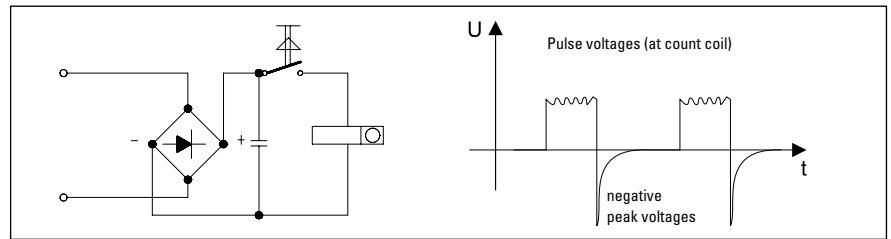

3 phase AC bridge circuit, capacitor not required, residual ripple 4.2 %:

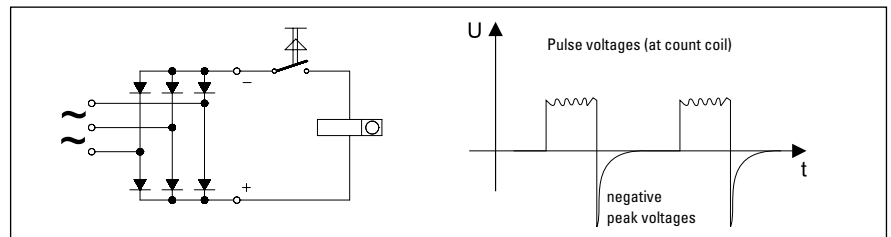

If the rectifiers are connected directly to AC mains, they can often become damaged due to 'contamination' from voltage spikes. These peak voltages are caused by the switching of transformers, spot welding machines, switching motors on and off etc; they often exceed the mains voltage by many times. Therefore it is essential to use a heavy duty rectifier or one with suppressor circuit, so that these peak voltages will not have any destructive effects in the long run.

This is particularly important in the case of silicon rectifiers which are very sensitive to short period excess voltages. It is advisable to use controlled avalanche silicon rectifiers for this purpose.

Rectifiers which we build in or attach to our pulse counters have to a large extent, a high dielectric strength, and an over voltage protection is provided, if required.

Pulse generators

Appropriate pulse generators are required in order to achieve accurate count results. In this connection, it should be ensured that these operate as far as possible without bounce; this is particularly important for counters with high pulse rate. Cam operated spring contacts, limit switches and micro switches are suitable for count speeds up to

10 or 25 Hz, small relay contacts up to approx. 40 Hz, higher count speed up to 60 Hz can be achieved with reed switches, exact matching of spark quenching being necessary to avoid premature sticking of contact reeds. Even higher speeds can be obtained by using photoelectric or inductive sensors.

Electrical reset

Counters with electrical reset have an electro-magnet which is operated by a reset pulse, and resets the number wheels back to the starting number. With remote reset via a pulse, the pulse duration must be long enough for the reset operation to be completed and for the minimum pulse duration to be maintained in accordance with the technical data of the counters. It is essential that during resetting no pulses may pass into the count mechanism, as otherwise intermediate positions of the number wheel or slippage of the drive mechanism can occur.

There is no danger of mechanical damage of the counter, however.

In order to avoid mistakes, the count pulses should only be allowed to enter, when the number wheels have been accurately adjusted and the drive mechanism is fully engaged. With remote reset a count interval of at least 50 msec after pulse end is required and thus the total count interval = reset pulse time + 50 msec.

Spark quenching

If the pulse contact is within the DC circuit of the counter, spark quenching is necessary in order to avoid any contact disturbance from the inductive breaking voltage.

Unfortunately, however, a more or less strong dropout delay is produced by the spark quenching and it should be checked in any case whether this will cause disturbance.

Spark quenching with RC element

This spark quenching produces practically no disturbing dropout delay and is, therefore most suitable for all count speeds. It should preferably be used at very high count speeds.

In general the RC element is located in parallel with the contact in order to produce high frequency interference suppression at the same time. However, it can also be connected in parallel with the coil.

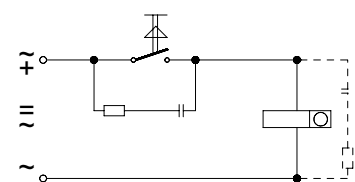

- Product overview Basics
- Pulse counters
- Preset counters
- Hour meters Timers
- Frequency displays Tachometers
- Position displays
- Multifunction devices
- Energy meters
- Process devices
- Temperature devices
- Strain-gauge controllers
- Accessories Index

Electromechanical counters

Basic technical information

Spark quenching with diodes

Considerable dropout delay, therefore only suitable for low count speeds up to 10 Hz. Particular attention should be paid to the correct polarity on connecting.

The small fitting size is an advantage: e.g. this type of spark quenching can be used for resetting coils.

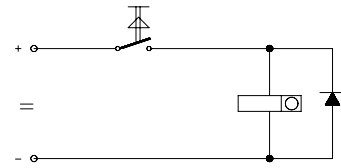

Spark quenching with zener diodes

Low dropout delay, therefore suitable for higher count speeds because the diode only passes the inductive breaking current when the zener voltage is achieved. It is also suitable for the protection of transistor circuits, where correct polarity must be observed.

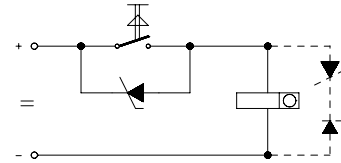

Spark quenching with varistors

Varistors are voltage dependent resistors whose resistance decreases inertialessly and exponentially with rising voltage. They are therefore, suitable for spark quenching, the varistor ideally being connected in parallel with the coil. It is rated for the current to be approx. 1/10 of the coil current at nominal voltage.

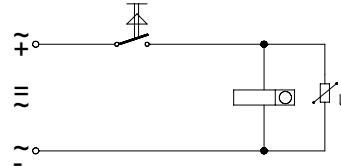

Identification of counter models

The design of the pulse counters is identified according to type series, version of front panel, and reset, according to the following system:

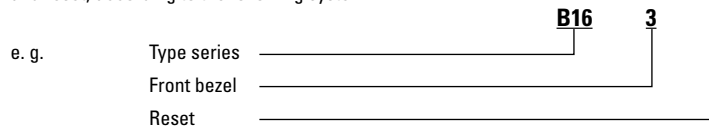

Electromechanical standard ranges

Please refer to the technical data for the various counters

Front bezel

- 0** = no front bezel
- 1** = front bezel for panel with 2 mounting holes
- 2** = front bezel with mounting clip
- 3** = large front bezel for panel with 2 mounting holes

Reset

- 0** = without reset
- 1** = manual
- 2** = electrical
- 3** = manual and electrical

For further codes, please refer to the respective counters.

Versions with coil

Max. possible frequency depends on the type of coil used:

Coil type	max. frequency
05	8 Hz at DC
0	10 Hz at DC
1	25 Hz at DC
a0	10 Hz at AC
a	18 Hz at AC

General instructions

Selecting the right count frequency is important in order to achieve optimal service life.

If a counter is only required to operate at a maximum of 10 Hz, then one for 25 Hz should not be used. This is primarily because of the higher service life of the 10 Hz version compared to the 25 Hz model. In addition the 10 Hz counter has a higher duty cycle and a lower power consumption than the one for 25 Hz.

The choice of spark quenching is also very important, particularly at high count speeds (refer to section on spark quenching). RC element, silicon diodes and some varistors can be obtained from us.

Certain counter types are supplied with a built in spark quenching. The explanations given in the above paragraphs and the technical specifications of each counter should be noted carefully.

Electronic counters	Versions		Product overview Basics
Overview	Electronic counters can be divided into:		Pulse counters
	<ul style="list-style-type: none"> • Pulse counters • Preset counters • Hour meters / Timers • Time preset counters • Tachometers • Position displays 		
Pulse counters	These counters have no outputs activated at a specific count value. They are used purely to monitor the count value.	Example:	Preset counters
	<p>The functions range from simple totalizing up to position display (with phase discriminator/quadrature). Depending on the speed of the events being counted, the count speed can go up to 100 kHz. More recent counters have a scale factor, which for example could be used to convert a length measured in inches into meters.</p>		Hour meters Timers
		Codix 130	
		Codix 520	
Preset counters	<p>The purpose of preset counters is to trigger a signal at a particular count value. In the simplest instance this can mean just shutting down a machine, however it could also be the initialisation of control functions (e.g. cutting material to length, transporting parts etc.).</p> <p>Relays, transistors or optocouplers are used as outputs. Relays are suitable for switching heavy loads (up to 2000 VA).</p> <p>The actual switching capacity depends on the model (counter) and can be seen in the data sheet. Most relays are available with a changeover function.</p>	Example:	Frequency displays Tachometers
			Position displays
		Codix 560	
		572	
			Multifunction devices
		901	
		Codix 923 / 924	
	Adding	Subtracting	Energy meters
	<p>The counter starts from zero and counts up to the programmed preset value, at which an output signal is triggered. The counter is then reset to zero - this can be programmed to happen automatically. The current count value is always displayed.</p>	<p>The counter starts from the preset value or from a separate setpoint and counts down to zero, at which an output signal is triggered. The counter is then reset to the preset value. The value displayed corresponds to the difference between the preset value and the count value.</p>	Process devices
Hour meters / Timers	<p>Timers measure the time in the unit of time, for which the device is laid out. With the electronic meters, the time base is programmable in hours, minutes or seconds or is displayed with two decimal places.</p> <p>The resolution is determined by the decimal point. Here the smallest possible resolution is milliseconds when operating in the short time meter mode (stop watch function). A time base of hours, minutes and seconds can also be programmed. The time counting starts when the supply voltage is applied to the meter, or is controlled by means of pulses using either the time-interval measuring principle or the pulse width (gate time) principle, with one or two separate inputs.</p>	Example:	Temperature devices
			Strain-gauge controllers
		Codix 13x	
		571T Touch	
			Accessories Index
		Codix 52U	

Electronic counters Versions

Time preset counters

Preset timers measure the time in the unit of time, for which the device is laid out (see also timers).
 With preset timers one, two, four or six outputs, as relay or optocoupler outputs, are additionally available.
 A particular output is activated, as soon as a pre-selected value is reached. This can occur both in adding or subtracting mode. The signal duration is programmable either as a momentary (timed) pulse or as a maintained (latched) pulse.

Example:



Codix 923 / 924

Tachometers

Tachometers measure pulses per unit of time, typically pulses per second with frequency measurements or pulses per minute with rotary speed measurement or production quantities and volumes.
 Two different measurement principles are used:
 - time-interval measurement, where the time between 2 pulses is measured
 - gate time (time base), where the number of pulses within a certain time window is measured
 The latest models use a mix of both principles, which offers a fast reaction time coupled with the greatest possible accuracy (HRA – High Rate Accuracy System).
 Devices with limit values can be used for monitoring rotary speed or rate of production.

Example:



Codix 560



Codix 923 / 924



574

Position displays

Position displays are devices, which measure pulses from rotary encoders or linear measurement systems, with incremental pulses or absolute position data.
 These displayed position values can be scaled using pulse weighting, which means that the display can be converted to any desired magnitude. Quadrature x1, x2 or x4 input pulse evaluation is available on displays that have incremental inputs.
 Type 572 has 2 separate incremental inputs for HTL or TTL signals up to max. 1 MHz. The two values can be mathematically calculated with respect to each other.
 Absolute systems are evaluated using the SSI protocol; singleturn as well as multiturn systems can be displayed and evaluated.
 The Kübler SSI display has a fast clock frequency up to 1 MHz, suitable for our absolute encoders. It has numerous programmable measurement functions, a freely scalable display, a scalable analog output, a serial interface and a up to 4 limit values.

Example:



571T Touch



572



Codix 52x



Codix 54x



Codix 92x



Codix 560

Product overview
Basics

Pulse counters

Preset counters

Hour meters
Timers

Frequency displays
Tachometers

Position displays

Multifunction
devices

Energy meters

Process devices

Temperature
devices

Strain-gauge
controllers

Accessories
Index

Electronic counters Basic technical information

Display types

Electronic counters are differentiated according to their display type. The most common types of displays used today are liquid-crystal displays (LCD) and light-emitting diodes (LEDs).



LCD displays

LCD displays have the advantage of being very economical. They are available in both standard versions and in customised versions.

The advantage of the customised version is that as well as the count value, it is possible to display the preset value and also additional symbols such as, for example, the status of the outputs. With customised models, the height of the digits and the size of the display can be optimally laid out for the corresponding counter.

LCD displays also have the advantage that they are not affected by ambient light and for poorly lit environments they are available with built-in backlighting. Note however that backlit displays do have higher power consumption.



LCD touch displays

LCD displays have the advantage of being very economical. They are available in both standard versions and in customised versions.

The individually addressable pixels allow displaying graphics as well as fixed or scrolling text. The resistive touch technology used by Kübler allows operation also when wearing gloves. The flat front side is easy to clean; the device can therefore be used also in the food industry.

The touch display offers comprehensive plain text menu programming, allowing operation without operating instructions.

Backlighting allows displaying various colors that can be switched when reaching a limit value. This function allows better event visualization.



LED displays

LED displays are always employed, if units are to be used in environments with diffuse lighting.

Due to their self-luminous display, these models are also easy to read even from a long distance. For each segment, LED displays require a current of between 2 and 10 mA. For a 6-digit counter that could mean from 90 to 450 mA.

As a rule 7-segment displays are the norm, although 14-segment displays or alphanumeric displays can be used to display message texts – as with the Codix 56x multifunction counters and process devices.

- Product overview Basics
- Pulse counters
- Preset counters
- Hour meters Timers
- Frequency displays Tachometers
- Position displays
- Multifunction devices
- Energy meters
- Process devices
- Temperature devices
- Strain-gauge controllers
- Accessories Index

Electronic counters

Basic technical information

Outputs

We offer our preset counters with various output options:

Relays, transistors and optocouplers

Relays should not be used when switching very small loads. Transistor or optocoupler outputs are better suited to operate the input of a controller. The design of both outputs is basically almost the same. However with the optocoupler, galvanic isolation is achieved between the unit (counter) and the peripheral (controller) because of an LED and a phototransistor (in one housing).

As a rule, with the optocoupler output the emitter and the collector are brought out and may have to be switched externally. Using the appropriate circuit it is possible to achieve either negative polarity (normally closed function) or positive polarity (normally open function).

Analog outputs

An analog output is available with the 57x multifunction devices, dual preset counters as well as with SSI displays.

Your benefits:

- Signal transducer and display with scaling and linearisation in one device
- Additional control of the measured value via 2 relay outputs
- Simple programming
- Transmission of the selected measured value, also over long distances with 4 ... 20 mA signal, to a higher-level controller, PC or a curve tracer
- Output of the current value, totalizer value, MIN or MAX value, programmable as 0 ... 20 mA, 4 ... 20 mA, 0 ... 10 V, 2 ... 10 V analog signal value

Optocoupler output with negative polarity

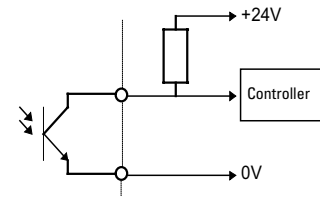

Optocoupler output with positive polarity

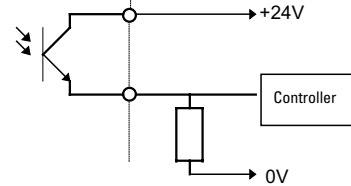

Inputs

The inputs of our counters are designed as transistor inputs. Either NPN or PNP type.

Negative input polarity (NPN)

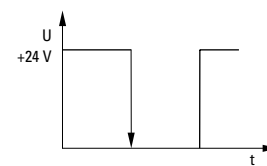
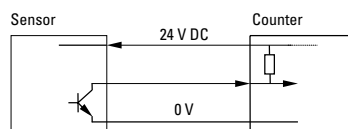

Positive input polarity (PNP)

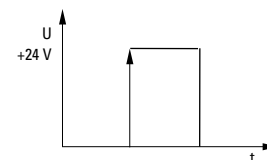
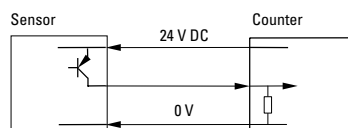

High voltage version 10 ... 250 V AC/DC

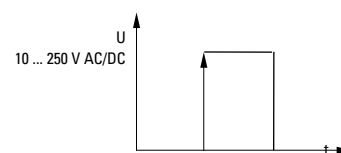
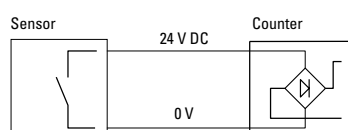

Electronic counters Input and output modes

Input modes: pulse counting

Function	Diagram	Note: P: No counting when GATE input is active Preset	PNP: NPN: Count on rising edge Count on falling edge
CNT.DIR Count Direction Mode			Inp A: Count input Inp B: Count direction Add: Display 0 → preset Sub: Display preset → 0
UP.DN Difference Mode			Inp A: Count input add Inp B: Count input sub Add: Display 0 → preset Sub: Display preset → 0
UP.UP Totalizer Mode			Inp A: Count input 1 add Inp B: Count input 2 add Add: Display 0 → preset
QUAD Phase Discriminator / with Quadrature			A 90° B Inp A: Count input – count on rising edge Inp B: Reverse direction Add: Display 0 → preset Sub: Display preset → 0
QUAD2 Phase Discriminator with Quadrature and pulse doubling			A 90° B Inp A: Count input – count on rising and on falling edges Inp B: Reverse direction Add: Display 0 → preset Sub: Display preset → 0
QUAD4 Phase Discriminator with Quadrature and pulse quadrupling			A 90° B Inp A: Count input – count on rising and on falling edges Inp B: Count input – count on rising and on falling edges, reverse direction Add: Display 0 → preset Sub: Display preset → 0
A / B Ratio			Inp A: Count input 1 Inp B: Count input 2 Formula: A / B
A % B Ratio in percentage			Inp A: Count input 1 Inp B: Count input 2 Formula: (A – B)/A x100

Electronic counters Input and output modes

Input modes: timing

Function	Diagram	Note: P: Preset	No counting when GATE input is active	PNP: Count on rising edge NPN: Count on falling edge
INA.INB Start – Input A Stop – Input B				Inp A: Start Inp B: Stop Add: Display 0 → preset Sub: Display preset → 0
INB.INB Start – Input B Stop – Input B				Inp A: No function Inp B: Start/Stop Add: Display 0 → preset Sub: Display preset → 0
FREE.RN Free Run				Inp A: No function Inp B: No function Control of the timing only via the GATE input Add: Display 0 → preset Sub: Display preset → 0
AUTO Automatic reset mode				Inp A: No function Inp B: No function Control of the timing only via reset (manual or electrical) Add: Display 0 → preset Sub: Display preset → 0
Speed From the operating time measurement	Special mode for 571T calculating the frequency (speed) from the measured time.			Inp A: Start Inp B: Stop

Product overview Basics
 Pulse counters
 Preset counters
 Hour meters Timers
 Frequency displays Tachometers
 Position displays
 Multifunction devices
 Energy meters
 Process devices
 Temperature devices
 Strain-gauge controllers
 Accessories Index

Electronic counters Input and output modes

Input modes: frequency meters

Function	Diagram	Note: P: No counting when GATE input is active Preset	PNP: Count on rising edge NPN: Count on falling edge																					
A Single Mode	<table border="1"> <tr> <td>INP A</td> <td>0</td> <td>F_{A0}</td> <td>F_{A1}</td> <td>F_{A2}</td> <td>0</td> <td>x</td> </tr> <tr> <td>Display</td> <td>0</td> <td>0</td> <td>F_{A0}</td> <td>F_{A1}</td> <td>F_{A2}</td> <td>0</td> </tr> </table>	INP A	0	F _{A0}	F _{A1}	F _{A2}	0	x	Display	0	0	F _{A0}	F _{A1}	F _{A2}	0		Inp A: Frequency input Inp B: No function							
INP A	0	F _{A0}	F _{A1}	F _{A2}	0	x																		
Display	0	0	F _{A0}	F _{A1}	F _{A2}	0																		
A - B Difference Mode	<table border="1"> <tr> <td>INP A</td> <td>0</td> <td>F_{A0}</td> <td>F_{A1}</td> <td>F_{A2}</td> <td>0</td> <td>x</td> </tr> <tr> <td>INP B</td> <td>0</td> <td>0</td> <td>F_{B0}</td> <td>F_{B1}</td> <td>F_{B2}</td> <td>x</td> </tr> <tr> <td>Display</td> <td>0</td> <td>0</td> <td>F_{A0}</td> <td>F_{A0} - F_{B0}</td> <td>F_{A1} - F_{B1}</td> <td>- F_{B2}</td> </tr> </table>	INP A	0	F _{A0}	F _{A1}	F _{A2}	0	x	INP B	0	0	F _{B0}	F _{B1}	F _{B2}	x	Display	0	0	F _{A0}	F _{A0} - F _{B0}	F _{A1} - F _{B1}	- F _{B2}		Inp A: Frequency input 1 Inp B: Frequency input 2 Formula: A - B
INP A	0	F _{A0}	F _{A1}	F _{A2}	0	x																		
INP B	0	0	F _{B0}	F _{B1}	F _{B2}	x																		
Display	0	0	F _{A0}	F _{A0} - F _{B0}	F _{A1} - F _{B1}	- F _{B2}																		
A + B Totalizing	<table border="1"> <tr> <td>INP A</td> <td>0</td> <td>F_{A0}</td> <td>F_{A1}</td> <td>F_{A2}</td> <td>0</td> <td>x</td> </tr> <tr> <td>INP B</td> <td>0</td> <td>0</td> <td>F_{B0}</td> <td>F_{B1}</td> <td>F_{B2}</td> <td>x</td> </tr> <tr> <td>Display</td> <td>0</td> <td>0</td> <td>F_{A0}</td> <td>F_{A0} + F_{B0}</td> <td>F_{A1} + F_{B1}</td> <td>F_{B2}</td> </tr> </table>	INP A	0	F _{A0}	F _{A1}	F _{A2}	0	x	INP B	0	0	F _{B0}	F _{B1}	F _{B2}	x	Display	0	0	F _{A0}	F _{A0} + F _{B0}	F _{A1} + F _{B1}	F _{B2}		Inp A: Frequency input 1 Inp B: Frequency input 2 Formula: A + B
INP A	0	F _{A0}	F _{A1}	F _{A2}	0	x																		
INP B	0	0	F _{B0}	F _{B1}	F _{B2}	x																		
Display	0	0	F _{A0}	F _{A0} + F _{B0}	F _{A1} + F _{B1}	F _{B2}																		
QUAD Frequency with direction	<table border="1"> <tr> <td>INP A</td> <td>0</td> <td>F_{A0}</td> <td>F_{A1}</td> <td>F_{A2}</td> <td>0</td> <td>x</td> </tr> <tr> <td>INP B</td> <td>0</td> <td>0</td> <td>F_{B0}</td> <td>F_{B1}</td> <td>F_{B2}</td> <td>x</td> </tr> <tr> <td>Display</td> <td>0</td> <td>0</td> <td>F_{A0}</td> <td>F_{A1}</td> <td>F_{A2}</td> <td>- F_{A3} - F_{A4}</td> </tr> </table>	INP A	0	F _{A0}	F _{A1}	F _{A2}	0	x	INP B	0	0	F _{B0}	F _{B1}	F _{B2}	x	Display	0	0	F _{A0}	F _{A1}	F _{A2}	- F _{A3} - F _{A4}		A 90° B Inp A: Frequency input 1 Inp B: Reverse direction
INP A	0	F _{A0}	F _{A1}	F _{A2}	0	x																		
INP B	0	0	F _{B0}	F _{B1}	F _{B2}	x																		
Display	0	0	F _{A0}	F _{A1}	F _{A2}	- F _{A3} - F _{A4}																		
A / B Ratio	<table border="1"> <tr> <td>INP A</td> <td>0</td> <td>F_{A0}</td> <td>F_{A1}</td> <td>0</td> <td>0</td> <td>x</td> </tr> <tr> <td>INP B</td> <td>0</td> <td>0</td> <td>F_{B0}</td> <td>F_{B1}</td> <td>F_{B2}</td> <td>x</td> </tr> <tr> <td>Display</td> <td>0</td> <td>0</td> <td>0</td> <td>F_{A0}/F_{B0}</td> <td>F_{A1}/F_{B1}</td> <td>0</td> </tr> </table>	INP A	0	F _{A0}	F _{A1}	0	0	x	INP B	0	0	F _{B0}	F _{B1}	F _{B2}	x	Display	0	0	0	F _{A0} /F _{B0}	F _{A1} /F _{B1}	0		Inp A: Frequency input 1 Inp B: Frequency input 2 Formula: A / B
INP A	0	F _{A0}	F _{A1}	0	0	x																		
INP B	0	0	F _{B0}	F _{B1}	F _{B2}	x																		
Display	0	0	0	F _{A0} /F _{B0}	F _{A1} /F _{B1}	0																		
A % B Ratio in percentage	<table border="1"> <tr> <td>INP A</td> <td>0</td> <td>F_{A0}</td> <td>F_{A1}</td> <td>0</td> <td>0</td> <td>x</td> </tr> <tr> <td>INP B</td> <td>0</td> <td>0</td> <td>F_{B0}</td> <td>F_{B1}</td> <td>F_{B2}</td> <td>x</td> </tr> <tr> <td>Display</td> <td>0</td> <td>0</td> <td>100%</td> <td>F_{A0}%F_{B0}</td> <td>F_{A1}%F_{B1}</td> <td>0</td> </tr> </table>	INP A	0	F _{A0}	F _{A1}	0	0	x	INP B	0	0	F _{B0}	F _{B1}	F _{B2}	x	Display	0	0	100%	F _{A0} %F _{B0}	F _{A1} %F _{B1}	0		Inp A: Frequency input 1 Inp B: Frequency input 2 Formula: (A - B)/A x100
INP A	0	F _{A0}	F _{A1}	0	0	x																		
INP B	0	0	F _{B0}	F _{B1}	F _{B2}	x																		
Display	0	0	100%	F _{A0} %F _{B0}	F _{A1} %F _{B1}	0																		
Operating time from the frequency (reciprocal rotary speed)	Special mode for 571T calculating the operating time from the frequency		Inp A: frequency input																					

Electronic counters

Input and output modes

Output modes

Function	Diagram
ADD Adding	
ADD.AR Adding + Automatic Reset	
ADD.BAT Adding + Batch Counter	
ADD.TOT Adding + Total Counter	
TRAIL Adding Output 1 is Tracking Preset of Output 2	

Function	Diagram
SUB Subtracting	
SUB.AR Subtracting + Automatic Reset	
SUB.BAT Subtracting + Batch Counter	
SUB.TOT Subtracting + Total Counter	
TR.AR Adding + Automatic Reset Output 1 is Tracking Preset of Output 2	

Product overview
Basics

Pulse counters

Preset counters

Hour meters
Timers

Frequency displays
Tachometers

Position displays

Multifunction
devices

Energy meters

Process devices

Temperature
devices

Strain-gauge
controllers

Accessories
Index

Process devices	Versions
------------------------	-----------------

Overview

Process devices are used for

- **Temperature**
- **Standard signals**
- **Strain-gauge**
- **Setpoint adjuster**

Temperature display, Temperature controller

The temperature displays measure temperatures very accurately (by means of inputs from a variety of temperature sensors) and display these in °C or °F using permanently stored characteristic curves.

Furthermore, some devices have an additional freely scalable mV or resistance input, in order to store custom curves and to compensate for sensor inaccuracies. With a resettable MIN/MAX value function, peak values can be precisely measured and retransmitted if required. A variety of thermocouples as well as resistance thermometers (RTDs) in 2, 3 or 4-wire technology can be connected. With running help texts and a quick-start guide, programming is very simple and user-friendly, despite the wide functionality.

The temperature controllers additionally boast 2 limit value alarms, which operate when the measured value exceeds or drops below the limit setpoint, or alternatively within a fixed band.

Thanks to features such as start delay, hysteresis function and averaging, they can be employed in the most diverse applications. They can also be used as simple ON/OFF controllers. The optional analog output or serial interface enable the retransmission of the measured values to higher-level systems or monitoring devices.

Example:



Codix 531



Codix 564

Standard signal displays, standard signal controllers

The standard signal displays measure values very accurately (by means of inputs from a variety of sensors that can be connected) and display these values, freely scalable, in the 5 or 6 digit display.

Furthermore, some devices offer the option to store custom characteristic curves, in order to compensate for sensor inaccuracies. With a resettable MIN/MAX value function, peak values can be precisely measured and retransmitted if required. Sensors with a 0/2 ... 10 V, ±10 V or 0/4 ... 20 mA output can be connected to give precise measuring results. With running help texts and a quick-start guide, programming is very simple and user-friendly, despite the wide functionality.

The standard signal controllers additionally boast 2 limit value alarms, which operate when the measured value exceeds or drops below the limit setpoint, or alternatively within a fixed band.

Thanks to features such as start delay, hysteresis function and averaging, they can be employed in the most diverse applications. They can also be used as simple ON/OFF controllers. The optional analog output or serial interface enable the retransmission of the measured values to higher-level systems or monitoring devices. A totalizer function sums the measured value with respect to time, in order to measure quantities or volume over a fixed time period.

Example:



Codix 534



Codix 565



573T Touch

Product overview Basics
Pulse counters
Preset counters
Hour meters Timers
Frequency displays Tachometers
Position displays
Multifunction devices
Energy meters
Process devices
Temperature devices
Strain-gauge controllers
Accessories Index

Process devices	Versions
-----------------	----------

Strain-gauge controller

The strain-gauge controllers measure values very accurately (by means of inputs from a selection of sensors that can be connected) and display these values, freely scalable, in the 6-digit 14-segment display.

These devices offer the option to store custom characteristic curves, in order to compensate for sensor inaccuracies. With a resettable MIN/MAX value function, peak values can be precisely measured and retransmitted if required. A variety of suitable sensors can be connected to the measuring bridge input to give precise measuring results.

With running help texts and a quick-start guide, programming is very simple and user-friendly, despite the wide functionality.

The strain-gauge controllers additionally boast 2 limit value alarms, which operate when the measured value exceeds or drops below the limit setpoint, or alternatively within a fixed band. Thanks to features such as start delay, hysteresis function and averaging, they can be employed in the most diverse applications. They can also be used as simple ON/OFF controllers. The optional analog output enables the retransmission of the measured values to higher-level systems or monitoring devices. A totalizer function sums the measured value with respect to time, in order to measure quantities or volume over a fixed time period.

Example:



Codix 566

Setpoint adjuster

The setpoint adjuster is a digital output device for 0 ... 12 V or 0 ... 24 mA standard signals suitable for plant commissioning or the simulation of sensors.

The current or voltage can be output in 3 modes, either directly, stepped or in a stored time curve (characteristic curve) and is thus ideal also for automatic sequences or approach operations in processes.

Furthermore the display is freely scalable, so that this can be shown in the desired engineering units. Thanks to its small design size and its flexibility, this device will prove indispensable in every workshop.

Example:



Codix 533

Product overview
Basics

Pulse counters

Preset counters

Hour meters
Timers

Frequency displays
Tachometers

Position displays

Multifunction
devices

Energy meters

Process devices

Temperature
devices

Strain-gauge
controllers

Accessories
Index

Basics

Process devices	Characteristics
-----------------	-----------------

Versatile and easy-to-read

The Codix range of devices from Kübler is the right solution whenever you wish to display and control process values (e.g. standard signals, temperature, pressure) or other analog measured values, or wish to convert and adapt measured variables.

Product overview
Basics

Small and compact

When mounting space is tight, then the Codix 531 to 534 models in their DIN 48 x 24 housing are the ideal solution.

When used to display standard or temperature input signals, the display can be scaled as desired. Furthermore Min/Max values or an overall total value can also be measured.



Pulse counters

Preset counters

Versatile and simple

If the device is to be operated with gloves, or if it must be legible from a great distance, then the Codix-Series 56X in its DIN 96 x 48 housing is the right choice.

These powerful and very fast displays set new standards when it comes to user friendliness.

Thanks to their easy-to-read 14-segment LED display, easy-to-understand running help texts and a practical quick-start guide, the need to wade through time-consuming full instruction manuals can be eliminated. The guide can be affixed directly to the front of the unit and can be removed and re-applied as required.

With 2 relay outputs and optional analog output, standard signals as well as temperature, pressure or weight can be optimally controlled and monitored.



Hour meters
Timers

Frequency displays
Tachometers

Position displays

Multifunctional

Multifunction process controller type 573T with LCD touch display, analog output, 4 limit values and serial interface.

The process controller with 2 analog inputs can be used in both single channel mode as well as in dual channel. In dual channel mode, all arithmetic operations are available for displaying the sum total, difference, ratio or the product. Inputs and outputs can be scaled separately.



Multifunction devices

Energy meters

Setpoint adjuster

Setpoint adjuster / time dependent process generator Codix 533.

The setpoint adjuster triggers a standard signal or a freely programmable signal sequence from 0 ... 12 V or from 0 ... 24 mA. The setpoint adjuster is a real innovation, opening up new application possibilities in process technology and automation.



Process devices

Temperature devices

Strain-gauge controllers

Accessories
Index

Process devices Characteristics

Application areas for process devices

- Level measurement
- Flow measurement
- Silos
- Speed display for processing machines
- Control cabinet cooling
- Woodworking machines
- Bakery plants
- Drying plants / ovens
- Packaging machines
- Machine tools and plastic processing machines
- Chemical and pharmaceutical plants
- Food and drink machines
- Semiconductor industry
- Energy supply and climate
- Paper machines
- Glass production machines
- Speed monitoring
- Stretch- and compression process monitoring
- Monitoring of synchronous operations
- Weighing and pressure technology

Application areas for setpoint adjusters

- Food, chemical and pharmaceutical plants
- Irrigation plants, pump control
- Mechanical engineering: for simulating sensors and speed control of motors and pumps, as well as for automatic lubricating of equipment
- Medical technology: for dosing, mixing or simulation
- Petrochemicals: for filling, mixing, simulation and for pump control
- Laboratory equipment, laboratory working places

Advantages of all process devices

- Galvanic isolation
- Linearisation function with up to 16 control points
- The Codix family concept means simple, unified operation
- Modern industrial design
- Short delivery times from stock
- Cost-effective price/performance ratio

Advantages of the Codix 533 setpoint adjuster / time-dependent process generator

- The setpoint adjuster offers three different operating modes:
 - Manual operation
 - Manual ramping operation
 - Automatic ramping operation
- With the automatic ramping operation, the times and setpoint values are programmed and then output automatically.
- With the manual operating modes, the value can either be preset directly or in stepped increments.

Example for automatic ramping operation:

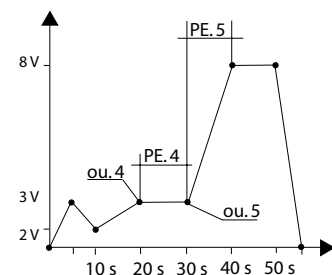

Analog output

Analog output with Codix 564 temperature controller, Codix 565 process controller for standard signals, Codix 566 process controller for strain-gauge inputs and type 573T process controller with 2 standard signal inputs.

Your benefits:

- Signal converter and display with scaling and linearisation in one device
- Additional ON/OFF control of the measured value via 2 relay outputs
- Simple programming via running help texts
- Transmission of the temperature values, pressure values, mV values or resistance values even over long distances, with a 4 ... 20 mA signal to a higher-level controller, PC or curve tracer.
- Output of the current value, totalizer value, MIN or MAX value, programmable as 0 ... 20 mA, 4 ... 20 mA, 0 ... 10 V, 2 ... 10 V value

Product overview
Basics

Pulse counters

Preset counters

Hour meters
Timers

Frequency displays
Tachometers

Position displays

Multifunction
devices

Energy meters

Process devices

Temperature
devices

Strain-gauge
controllers

Accessories
Index

Process devices Characteristics

Why process devices with an analog input?

For many measuring operations a digital signal acquisition is too inaccurate or involves too much time and effort. This is why analog signal acquisition is often used in industrial environments. This includes for example temperature, weight (mass), pressure, filling level, volume (flow), speed, acceleration, position and many others. The sensor signals are mostly very small (in the mV or μ V range). The KÜBLER process controllers amplify these signals, correcting possible errors, and send them to the display.

The signal conditioners Codix 564, 565, 566 convert these signals into standard signals (e.g. 0 ... 10 V or 4 ... 20 mA). These signals can then be further processed and/or displayed.

The option also exists to transmit the analog output signals over large distances. Many sensors do not provide a linear output signal. The KÜBLER process displays linearise these signals with up to 16 control points, depending on the model.

Input signals and output signals

For the input signals, depending on the model, KÜBLER offers the following ranges:

- 0 ... 20 mA
- 4 ... 20 mA
- ± 100 mV, ± 10 V
- 0 ... 10 V DC
- 2 ... 10 V DC
- 0 ... 500 Ω
- Pt100, Ni100 for 2, 3 and 4-wire technology
- Thermocouples B, E, J, K, N, R, S, T

The 2 ... 10 V and 4 ... 20 mA signals have the advantage that they also offer sensor monitoring at the same time. A 0 V or 0 mA signal may for instance mean that the sensor line is broken.

Example:

A digital display with analog input, e.g. Codix 565, can be used to replace or complement a pressure gauge on a compressor. The current signal of the pressure sensor is displayed as pressure on the display.

Programming of the characteristic curve:

Point 1: 4 mA, 2.5 Pa

Point 2: 20 mA, 30 Pa

Minimum and maximum values are saved and can be called up at any time. The display value can easily be scaled, to show for example atmospheres or bar instead of Pa, by modifying the points of the characteristic curve.

With the Codix 564, 565, 566 and with type 573T KÜBLER offers the following output signal ranges for further processing:

- 0 ... 20 mA, 4 ... 20 mA, 20 ... 4 mA, 20 ... 0 mA
- 0 ... 10 V, 2 ... 10 V, 10 ... 0 V, 10 ... 2 V, ± 10 V

Optocoupler or relay outputs in conjunction with adjustable limit values.

The 2 ... 10 V, 4 ... 20 mA and und 10 ... 2 V, 20 ... 4 mA signals have the advantage that they also offer sensor monitoring at the same time.

A 0 V or 0 mA signal may for instance mean that the sensor line is broken.

This value can be programmed separately for cases where a fault occurs.

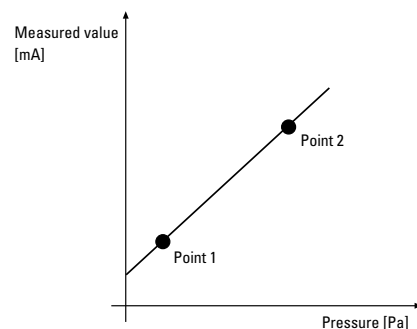

The function of the totalizer

The devices equipped with the totalizer function (Codix 534, 565, 566) can calculate the integral, that is to say "totalize" the analog signal, using any period of time (with the Codix 566 this is done by manual totalizing).

A typical field of application is flow measurement.

In this case, an analog sensor measures the flow quantity per time unit in a pipe and displays the momentary flow value (e.g. litres per minute).

From this constantly fluctuating quantity the totalizer calculates a "total", that is to say it defines the absolute quantity that has flowed through the pipe (e.g. in litres).

Process devices

Characteristics

Which temperature display / controller is the right one for you?

The device must be chosen according to the temperature sensor used.

Pt and Ni resistance sensors:

Temperature measurement with resistance sensors uses the temperature sensitivity of metal resistances. A constant current is applied to the measuring resistance. The voltage drop at the resistance is measured. This drop represents the temperature measurement.

KÜBLER offers the following devices for resistance sensors:

Codix 531, Codix 564

Thermocouple sensors:

Temperature measurement with thermocouple sensors uses the thermoelectric effect. Thermocouples consist of two wires, soldered together.

The wires are made of different metals. The thermoelectric voltage appearing at the soldering point is measured, amplified and displayed by the KÜBLER display.

KÜBLER offers the following devices for thermocouple sensors:

Codix 532, Codix 564

The Codix 564 display is suitable for resistance sensors as well as for thermocouples.

Information about 2, 3 or 4 wire circuits

Unlike thermocouples, which deliver a voltage, a resistance does not deliver any signal by itself. This means that it requires external energy from an electrical measuring circuit. This power source is generally a constant current source.

With the 2 wire circuit, the measuring resistance is connected to the measuring device by means of two wires. The conductors are connected serially with the measuring resistance and lead to a higher total resistance, and thus to a measuring error.

With the 3 wire circuit, an additional wire is connected to the resistance, resulting in two measuring circuits. The resistance of the conductors is compensated for by means of internal circuits, provided all three conductors are identical.

With the 4 wire circuit, the resistance of all conductors is compensated for, even if they have different lengths.

Overview of the temperature measuring range

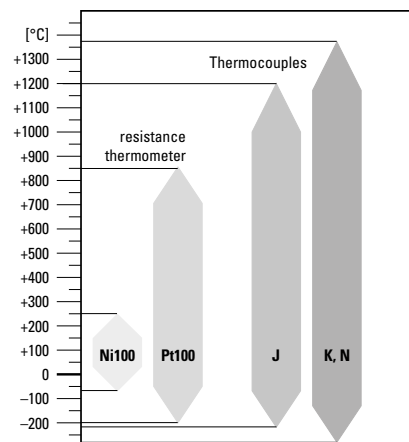

The diagram opposite shows an overview of the temperature range of the various sensors.

Advice:

- for Pt100 resistance sensors adhere to DIN IEC 751
- for Ni100 resistance sensors adhere to DIN 43760
- for thermocouple sensors adhere to DIN IEC 584.
- J: (Fe-CuNi)
- K: (Ni-CrNi)
- N: (NiCrSi-NiSi)

J: (Fe-CuNi)

These thermocouples are very common, economic and deliver a high thermoelectric voltage. Disadvantage: danger of corrosion. Iron becomes brittle with sulphurous gases.

K: (Ni-CrNi)

These thermocouples are very common, demonstrate excellent long-term stability but only have a low thermoelectric voltage.

N: (NiCrSi-NiSi)

These thermocouples are not common, since they appeared only recently on the market. They can be used for very high temperatures and can replace elements out of noble metal.

Process devices	Applications
-----------------	--------------

Temperature monitoring in a tubular furnace

When the process temperature is higher or lower than the set value, the heating of the oven is directly controlled by means of the relay outputs of the Codix 564 temperature controller.

In case of very high power, the process controller can also drive a power contactor.

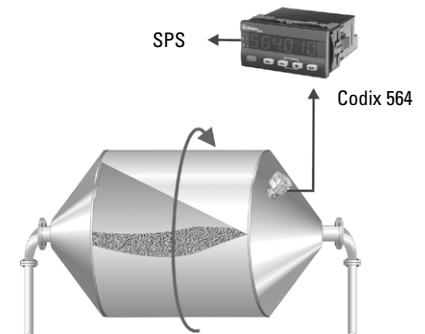

Product overview
Basics

Pulse counters

Preset counters

Linearisation of the characteristic curve of a container

Our process controllers linearise the relationship between the fill-up level h and the volume V of the container. This can be set exactly thanks to 12 or 16 control points.

The devices of the Codix 565 or type 573T can output the linearised values as current or as voltage values (e.g. 4 ... 20 mA) and thus offer in addition the function of a voltage transformer.

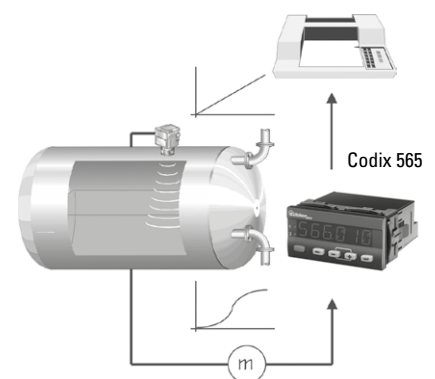

Hour meters
Timers

Frequency displays
Tachometers

Control of the heating of a furnace

The furnace temperature is monitored thanks to a temperature sensor. When the temperature becomes higher or lower than a defined temperature, the Codix 564 sends an output signal to the PLC, which controls, among others, the heating of the furnace. The operator can read the temperature on the large LED display.

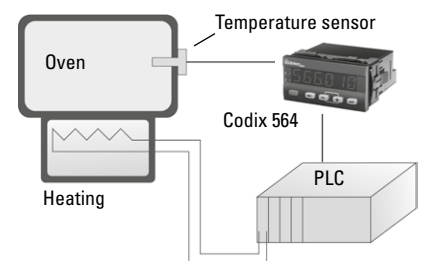

Position displays

Multifunction devices

Measurement of the total throughput [m³] and of the flow [l/min]

Thanks to its double function, the Codix 534 or 565 measures the total throughput in [m³] and the momentary flow in [l/min]. The sensor delivers a current signal proportional to the flow:

- 0 mA => 0 l/min
- 20 mA => 1000 l/min.

The total volume is calculated by the integration function (totalizer). Switching of the display is carried out by the front key.

The Codix 565 has two additional limits and an optional analog output.

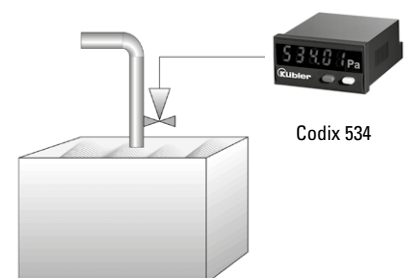

Energy meters

Process devices

Temperature devices

Weight determination

A strain gauge tape or a strain gauge bridge measures the pressure of the item to be weighed. The differential signal voltage lies in the mV range and this is converted to the desired weight and displayed by a Codix 566.

Strain gauges with 3.3 – 3.0 – 2.0 – 1.5 and 1.0 mV/N sensitivity can be connected directly to the input of the Codix 566.

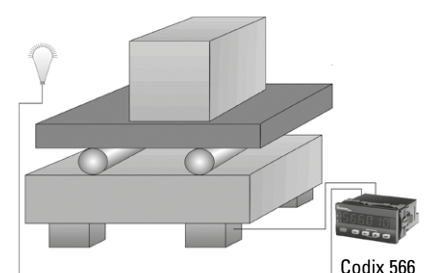

Strain-gauge controllers

Accessories
Index

Interfaces

Kübler counters use the following serial interfaces:

- RS232
- RS422
- RS485

Serial interface RS232

The serial interface RS232 is a full-duplex point-to-point connection.

Full-duplex means that data can be both transmitted and received simultaneously via the interface and that only two devices can be connected with each other. If two devices are to be connected to a computer, then a second interface port is required on the computer. The two connections are totally independent from each other.

This method has a disadvantage, because interface cards for PLCs are expensive and with PCs a maximum of 4 ports are available for use. For this reason, more recent Kübler counters are equipped with either the RS422 or the RS485 interface.

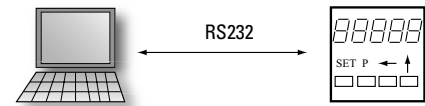

At least a 3-wire cable is needed when connecting RS232. The connection then works without handshaking. For connections with handshaking a 5-wire cable is needed.

Serial interface RS422

This interface is a full-duplex multi-point connection. This means that several receivers can be connected to one transmitter cable. In counting technology the PC or the PLC are used as the master station, which then controls all activity on the serial line.

All devices 'listen' to what the master is transmitting, but only that device, which is being addressed, answers. A message can only be sent from one device to another via the master.

Connecting the PC standard RS232 port to the RS422 counter interface is done by means of a simple interface converter. By using this solution, up to 10 devices can be connected to the serial port of a PLC or PC.

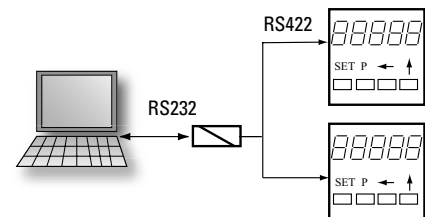

The wiring is done using a 4-wire cable with all the devices being connected in parallel. Each device has to be assigned a unique address, so that it can distinguish between messages being sent to its own address and those for another address.

Serial interface RS485

This interface is a half-duplex multi-point connection.

Half-duplex means that the data exchange works in both directions, but only in one direction at a time. It also means that one can transmit and receive over the same line. Converting the common RS232 interface to RS485 is not so easily done. However several devices can act as masters as well as also being receivers (slaves).

In total up to 32 devices can be connected to one interface. When connecting the stations together, only a two-wire cable is necessary. Most fieldbuses operate on this interface basis. The hardware is thus always the same, it is only the protocol that differs - this says which device is being addressed, which information is for that device and what control information is required to check that the transmission has been done correctly.

Interface comparison

Interface	RS232	RS422	RS485
Mode of transmission	asymmetrical with respect to GND	symmetrical without earth connection	
No. of senders	1	1	32
No. of receivers	1	10	32
Transmission distance	15 m [49.2']	1200 m [3937']	1200 m [3937']
Transfer rate	20 kBit/s	10 Mbit/s	10 Mbit/s
Sender output signal without load	+/-15 Volt	+5 Volt	+5 Volt
Driver load	3.7 kOhm	120 Ohm	60 Ohm

Software

Software OS6.0

- User-friendly programming software for displays 570T, 571T, 572, 573T, 574 and 575 with serial interface
- Upload and download functions
- Monitor and terminal program for simple diagnostics
- Online display of measured values in the monitor program
- Free download from our website

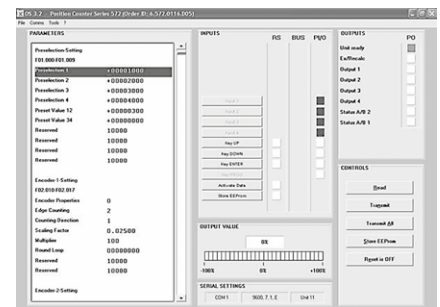

- Product overview
- Basics
- Pulse counters
- Preset counters
- Hour meters
- Timers
- Frequency displays
- Tachometers
- Position displays
- Multifunction devices
- Energy meters
- Process devices
- Temperature devices
- Strain-gauge controllers
- Accessories
- Index



Accessories
Index

Strain-gauge
controllers

Temperature
devices

Process devices

Energy meters

Multifunction
devices

Position displays

Frequency displays
Tachometers

Hour meters
Timers

Preset counters

Pulse counters

Product overview
Basics

Pulse counters

Pulse counters, electronic		Type	Page
LCD pulse counters	Adding or subtracting (battery)	Codix 130	48
	With count direction DC or difference counter AC+DC (battery)	Codix 131	51
	With count direction AC (battery)	Codix 132	54
	Adding counter (DC)	Codix 140	57
LCD service counters	Adding service counter (DC)	Codix 142	57
LED pulse counters	Adding (DC)	Codix 520	60
	6 count modes (DC)	Codix 521	63
	Multifunctional – pulse, frequency, time (DC)	Codix 524	240
	Universal with dual functions 4 combinations (DC)	Codix 52U	250
	6 count modes with tachometer (DC)	Codix 52P	254
	2 counters with separate scaling (DC)	Codix 52T	66
	2 counters with separate inputs and separate scaling (DC)	Codix 52C	69
	Adding (AC+DC)	Codix 540	72
	6 count modes (AC+DC)	Codix 541	75
	Multifunctional – pulse, frequency, time (AC+DC)	Codix 544	244
	Universal with dual functions 4 combinations (AC+DC)	Codix 54U	258
	6 count modes with tachometer (AC+DC)	Codix 54P	261
LCD touch counter	 Pulse, frequency, time (also reciprocal) – (AC+DC)	571T	247
LCD modules	Adding, 7 digits (DC)	190	78
	Adding, 6 digits (DC)	192	80
Pulse counters, electromechanical		Type	Page
Micro counters	High shock resistance (DC)	K 46 / K 47	82
	Magnetic field resistant and high shock resistance (DC)	K 66 / K 67	85
	High shock resistance (AC+DC)	K 04 ... K07 / AK 07	88
	High shock resistance, for DIN-rail (AC+DC)	SK 07	94
Mini counters	5 digits with reset (AC+DC)	W 15	96
	6 or 7 digits without reset (AC+DC)	W 16 / W 17	99
Standard counters	4 digits with reset (AC+DC)	Bk 14	102
	6 or 8 digits with/without reset (AC+DC)	B 16 / B 18	104
	4 or 6 digits with/without reset, electrical reset (AC+DC)	Mk 14 / Mk 16	110
Dual function counters	Pulse + time (AC+DC)	HC 77	208
	Pulse + time for DIN rail (AC+DC)	SHC 77	211
	Energy and time (AC)	HW 66 / HW 66 M	266
Pulse counters, pneumatic		Type	Page
Pneumatic counters	4 digits with, 6 digits with/without, 8 digits without reset	PMk 14 / PMk 16 / PMk 18	114

Product overview
Basics

Pulse counters

Preset counters

Hour meters
Timers

Frequency displays
Tachometers

Position displays

Multifunction
devices

Energy meters

Process devices

Temperature
devices

Strain-gauge
controllers

Accessories
Index

LCD pulse counters **Adding or subtracting (battery)** **Codix 130**



The Codix 130 is a simple battery powered pulse counter for fast and slow count pulses with 8-digit LCD display, optional backlighting, for NPN, PNP and high voltage applications.



Battery powered	Input type	Pulse voltage	Pulse voltage	Max. count frequency	Temperature range	High protection level	DIN front bezel	LCD display	Lockable reset

Powerful

- High quality LCD display with 8 mm high figures.
- Count direction adding and subtracting via control input.
- Battery life approx. 8 years.
- Optional display backlighting.
- Filter function for bounce-free counting with mechanical contacts.
- Count frequency max. 12 kHz.
- High protection level IP65.

Simple

- Screw terminals, RM 5 mm.
- Reset key can be enabled via "Reset Enable" input.
- For positive and negative counting edges, depending on version.
- High voltage version for 10 ... 260 V AC/DC voltage pulses.
- Large 8-digit LCD display with 8 mm high figures.

Order code 6.130 . 012 . 8XX

a Backlighting
5 = without¹⁾
6 = with¹⁾

b Input type: add/sub²⁾ – single-channel, adding or subtracting counting

Input type	INP A			INP B				
0 ¹⁾ = add/sub ²⁾	0 ... 0.7 V DC	count	NPN	7 kHz	0 ... 0.7 V DC	count	NPN	30 Hz
2 ¹⁾ = add/sub ²⁾	4 ... 30 V DC	count	PNP	12 kHz	0 ... 0.7 V DC	count	NPN	30 Hz
3 ¹⁾ = add/sub ²⁾	10 ... 260 V AC/DC	count	AC/DC	30 Hz	10 ... 260 V AC/DC	reset	AC/DC	–

Delivery specification

- Pulse counter
- Mounting clip
- Front bezel for screw mounting (T008181) 56 x 40 mm [2.20 x 1.57"], panel cut-out 50 x 25 mm [1.97 x 0.98"]
- Front bezel for clip mounting (T008180) 53 x 28 mm [2.09 x 1.10"], panel cut-out 50 x 25 mm [1.97 x 0.98"]
- Gasket
- Instruction manual, multilingual

1) Stock types.
2) Single-channel, adding or subtracting counting.

Pulse counters, electronic

LCD pulse counters	Adding or subtracting (battery)	Codix 130
Accessories	Dimensions in mm [inch]	Order no.
Adapter front bezel, 72 x 36 [2.83 x 1.42]	for cut-out 68 x 33 [2.68 x 1.30] to cut-out 45 x 22.2 [1.77 x 0.87], for counters 48 x 24 [1.89 x 0.94], as set	black and silver anodised 162704 Set
Adapter front bezel, 48 x 48 [1.89 x 1.89]	for cut-out 45 x 45 [1.77 x 1.77] to cut-out 45 x 22.2 [1.77 x 0.87], with clip mounting for counters 48 x 24 [1.89 x 0.94]	black T008883
Adapter front bezel, 60 x 50 [2.36 x 1.97]	for cut-out 54 x 29 [2.13 x 1.14] to cut-out 45 x 22.2 [1.77 x 0.87], with screw mounting and gasket for counters 48 x 24 [1.89 x 0.94]	black N003001
Transparent cover, lockable, IP65	for cut-out 54 x 29 [2.13 x 1.14], for screw mounting to front bezel F1B or adapter front bezel N003001, for counters with cut-out 50 x 25 [1.97 x 0.98] or 45 x 22.2 [1.77 x 0.87]	N003002
Sealing cover type K1, IP65	suitable for front bezel 60 x 50 [2.36 x 1.97], for screw mounting of electromech. counters and via adapter front bezel N003001 for counters 48 x 24 [1.89 x 0.94]	G008301
Mounting frame with cut-out 50 x 25 [2.36 x 1.97] via separate adapter also for 45 x 22.2 [1.77 x 0.87]	for snap-on mounting on 35 [1.38] top-hat DIN rail, for counters 53 x 28 [2.09 x 1.10] and via separate adapter (T008180) for counters 48 x 24 [1.89 x 0.94]	chromated G300004

Suitable gaskets, other accessories and installation examples for optional accessories can be found in chapter accessories or in the accessories section under: www.kuebler.com/accessories.

Technical data

General technical data	
Display	LCD, 8 digits, 8 mm [0.32"] high
Backlighting	external electrical source 24 V DC $\pm 20\%$, 50 mA
Modes	adding or subtracting (selectable)
Display range	-9999999 ... 99999999, with overflow display
Reset	manual and electrical
Working temperature	-10°C ... +55°C [+14°F ... +131°F] (non-condensing)
Operating temperature	-10°C ... +60°C [+14°F ... +140°F] (non-condensing)
Storage temperature	-20°C ... +70°C [-4°F ... +158°F]
Altitude	up to 2000 m [6562']

Electrical characteristics	
Power supply	internal lithium battery approx. 8 years at 20°C [68°F]
EMC standards	EN 55011 class B, EN 61000-6-2, EN 61000-6-3
Device safety	designed to protection class application area EN 61010 part 1 2 pollution level 2
UL approval	file E128604

Mechanical characteristics	
Housing	dark grey RAL 7021
Protection	IP65 (front side)
Weight	approx. 50 g [1.76 oz]

Counting inputs	
Counting input of the DC-versions (max. 30 V DC)	
slow counting input	max. 30 Hz NPN
fast counting input	max. 12 kHz (PNP), 7 kHz (NPN)
switching level NPN	LOW 0 ... 0.7 V DC HIGH 3 ... 30 V DC
switching level PNP	LOW 0 ... 0.7 V DC HIGH 4 ... 30 V DC
Counting input of the high voltage versions (10 ... 260 V DC/V AC)	
optocoupler input,	max. 30 Hz
min. pulse time	16 ms
switching level	LOW 0 ... 2 V AC/DC HIGH 10 ... 260 V AC/DC
Counting direction switching (only DC-version)	
mode	adding / subtracting
contact input	open collector NPN (switching at 0 V)
switching level NPN	LOW 0 ... 0.7 V DC HIGH 3 ... 5 V DC
Reset input (only DC and high voltage)	
minimum pulse time	DC 50 ms high voltage 16 ms
contact input DC – NPN	LOW 0 ... 0.7 V DC HIGH 3 ... 30 V DC
high voltage input	10 ... 260 V AC/DC
Electrical reset key locking (for DC and high voltage)	
contact input	open collector NPN (switching at 0 V)
switching level NPN	LOW 0 ... 0.7 V DC HIGH 3 ... 5 V DC

Pulse counters, electronic

LCD pulse counters Adding or subtracting (battery) Codix 130

Terminal assignment

DC type: 6.130.012.8x0

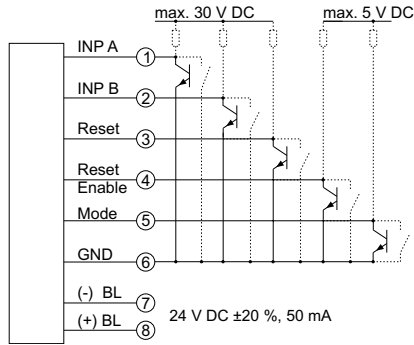

DC type: 6.130.012.8x2

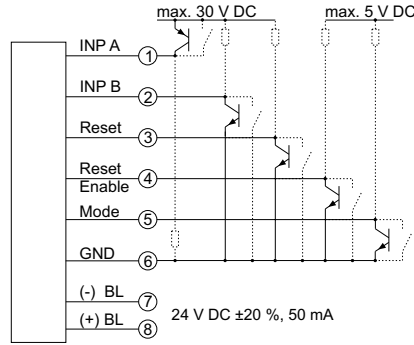

AC type: 6.130.012.8x3

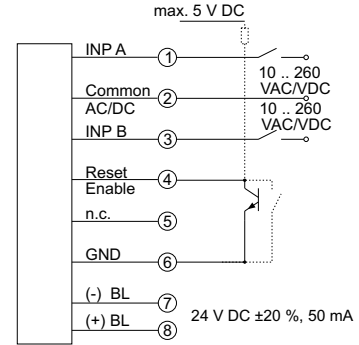

BL = backlighting

Dimensions

Dimensions in mm [inch]

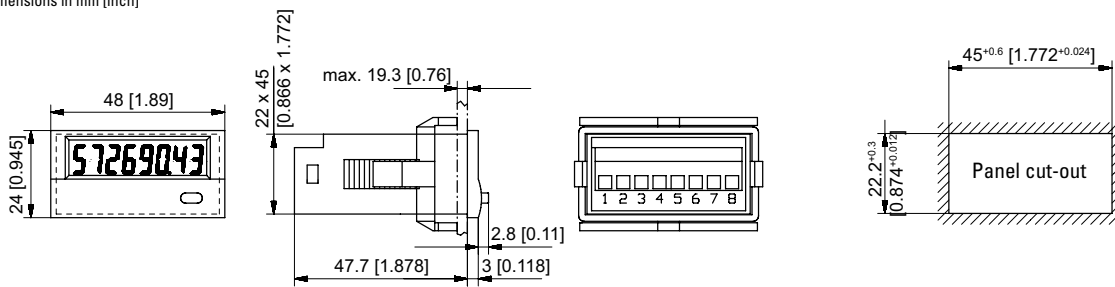

Front bezel for clip mounting (included in delivery)

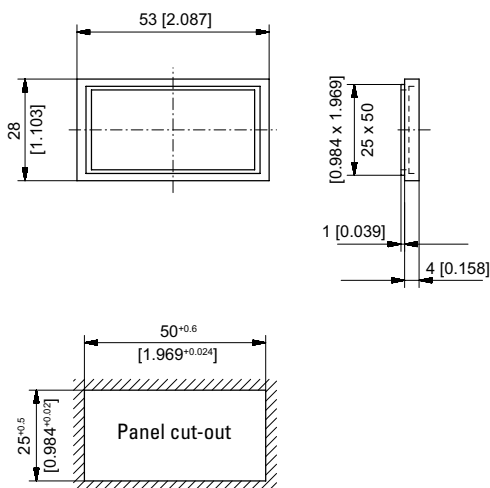

Front bezel for screw mounting (included in delivery)

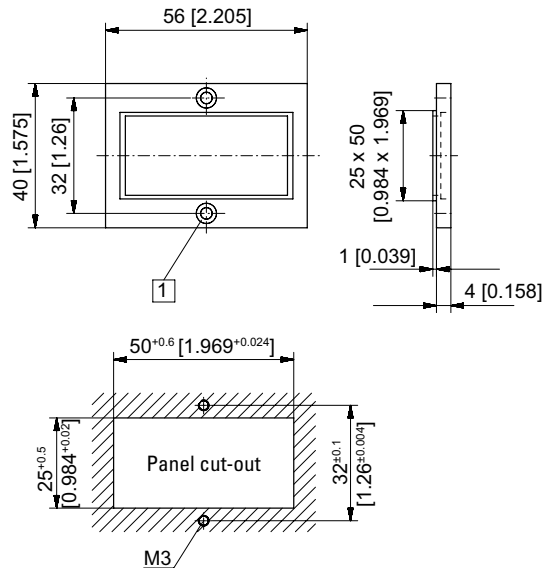

1 Countersinking Af3, DIN 74

Product overview
Basics

Pulse counters

Preset counters

Hour meters
Timers

Frequency displays
Tachometers

Position displays

Multifunction
devices

Energy meters

Process devices

Temperature
devices

Strain-gauge
controllers

Accessories
Index

LCD pulse counters **With count direction DC or difference counter AC+DC (battery)** **Codix 131**



The Codix 131 is a simple battery powered pulse counter with difference or count direction input, 8-digit LCD display, optional backlighting, for NPN, PNP and high voltage applications.



Battery powered	Input type	Pulse voltage	Pulse voltage	Count with direction (DIR)	Differential count (up, dn)	Max. count frequency	Temperature range	High protection level	LCD display

Powerful

- High quality LCD display with 8 mm high figures.
- Count direction, adding and subtracting via count direction or difference input.
- Battery life approx. 8 years.
- Optional display backlighting.
- Count frequency max. 12 kHz.
- High protection level IP65.

Simple

- Screw terminals, RM 5 mm.
- Reset key can be enabled via "Reset Enable" input.
- For positive and negative counting edges, depending on version.
- High voltage version for 10 ... 260 V AC/DC voltage pulses.
- Large 8-digit LCD display with 8 mm high figures.

Order code

6.131 . 012 . 8XX
a b

a Backlighting
 5 = without ¹⁾
 6 = with

b Input type: Cnt.Dir²⁾ / UP.DN³⁾ – count direction or differential counting

Input type	INP A			INP B		
0 ¹⁾ = Cnt.Dir ²⁾ / UP.DN ³⁾	0 ... 0.7 V DC	count	NPN	7 kHz	0 ... 0.7 V DC	count / direction
1 ¹⁾ = Cnt.Dir ²⁾ / UP.DN ³⁾	4 ... 30 V DC	count	PNP	12 kHz	4 ... 30 V DC	count / direction
3 = UP.DN ³⁾	10 ... 260 V AC/DC	count	AC/DC	30 Hz	10 ... 260 V AC/DC	count

Delivery specification

- Pulse counter
- Mounting clip
- Front bezel for screw mounting (T008181) 56 x 40 mm [2.20 x 1.57"], panel cut-out 50 x 25 mm [1.97 x 0.98"]
- Front bezel for clip mounting (T008180) 53 x 28 mm [2.09 x 1.10"], panel cut-out 50 x 25 mm [1.97 x 0.98"]
- Gasket
- Instruction manual, multilingual

1) Stock types.
 2) Counting input with counting direction input.
 3) One adding and one subtracting counting input (differential mode).

Pulse counters, electronic

LCD pulse counters With count direction DC or difference counter AC+DC (battery) Codix 131

Accessories	Dimensions in mm [inch]	Order no.
Adapter front bezel, 72 x 36 [2.83 x 1.42]	for cut-out 68 x 33 [2.68 x 1.30] to cut-out 45 x 22.2 [1.77 x 0.87], for counters 48 x 24 [1.89 x 0.94], as set black and silver anodised	162704 Set
Adapter front bezel, 48 x 48 [1.89 x 1.89]	for cut-out 45 x 45 [1.77 x 1.77] to cut-out 45 x 22.2 [1.77 x 0.87], with clip mounting for counters 48 x 24 [1.89 x 0.94] black	T008883
Adapter front bezel, 60 x 50 [2.36 x 1.97]	for cut-out 54 x 29 [2.13 x 1.14] to cut-out 45 x 22.2 [1.77 x 0.87], for screw mounting and gasket for counters 48 x 24 [1.89 x 0.94] black	N003001
Transparent cover, lockable, IP65	for cut-out 54 x 29 [2.13 x 1.14], for screw mounting to front bezel F1B or adapter front bezel N003001, for counters with cut-out 50 x 25 [1.97 x 0.98] or 45 x 22.2 [1.77 x 0.87]	N003002
Sealing cover type K1, IP65	suitable for front bezel 60 x 50 [2.36 x 1.97], for screw mounting of electromech. counters and via adapter front bezel N003001 for counters 48 x 24 [1.89 x 0.94]	G008301
Mounting frame with cut-out 50 x 25 [2.36 x 1.97] via separate adapter also for 45 x 22.2 [1.77 x 0.87]	for snap-on mounting on 35 [1.38] top-hat DIN rail, for counters 53 x 28 [2.09 x 1.10] and via separate adapter (T008180) for counters 48 x 24 [1.89 x 0.94] chromated	G300004

Suitable gaskets, other accessories and installation examples for optional accessories can be found in chapter accessories or in the accessories section under: www.kuebler.com/accessories.

Technical data

General technical data	
Display	LCD, 8 digits, 8 mm [0.32"] high
Backlighting	external electrical source 24 V DC $\pm 20\%$, 50 mA
Modes	counting direction (count and direction input) or differential counting
Display range	-9999999 ... 99999999, with overflow display
Reset	manual and electrical
Working temperature	-10°C ... +55°C [+14°F ... +131°F] (non-condensing)
Operating temperature	-10°C ... +60°C [+14°F ... +140°F] (non-condensing)
Storage temperature	-20°C ... +70°C [-4°F ... +158°F]
Altitude	up to 2000 m [6562']

Electrical characteristics	
Power supply	internal lithium battery approx. 8 years at 20°C [68°F]
EMC standards	EN 55011 class B, EN 61000-6-2, EN 61000-6-3
Device safety	designed to EN 61010 part 1 protection class 2 application area pollution level 2
UL approval	file E128604

Mechanical characteristics	
Housing	dark grey RAL 7021
Protection	IP65 (front side)
Weight	approx. 50 g [1.76 oz]

Counting inputs	
Counting input of the DC-versions (max. 30 V DC)	
fast counting input	max. 12 kHz (PNP), 7 kHz (NPN)
switching level NPN	LOW 0 ... 0.7 V DC HIGH 3 ... 30 V DC
switching level PNP	LOW 0 ... 0.7 V DC HIGH 4 ... 30 V DC
Counting input of the high voltage versions (10 ... 260 V DC/AC)	
A subtracting optocoupler input	max. 30 Hz
B adding min. pulse time	16 ms
switching level	LOW 0 ... 2 V AC/DC HIGH 10 ... 260 V AC/DC
Counting direction switching (only DC-version)	
mode	count direction / difference
contact input	open collector NPN (switching at 0 V DC)
switching level – NPN	LOW 0 ... 0.7 V DC HIGH 3 ... 5 V DC
Reset input (only DC and high voltage)	
minimum pulse time	DC 50 ms high voltage 16 ms
contact input DC – NPN	LOW 0 ... 0.7 V DC HIGH 3 ... 30 V DC
Electrical reset key locking (only DC and high voltage)	
contact input	open collector NPN (switching at 0 V DC)
switching level – NPN	LOW 0 ... 0.7 V DC HIGH 3 ... 5 V DC

Pulse counters, electronic

LCD pulse counters With count direction DC or difference counter AC+DC (battery) Codix 131

Terminal assignment

DC type: 6.131.012.8x0

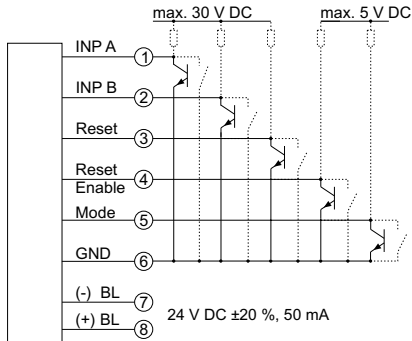

DC type: 6.131.012.8x1

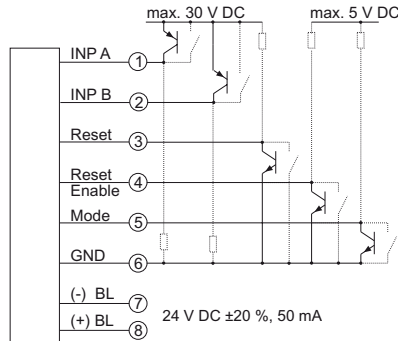

AC type: 6.131.012.8x3

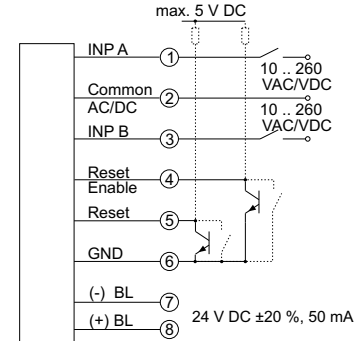

BL = backlighting

Dimensions

Dimensions in mm [inch]

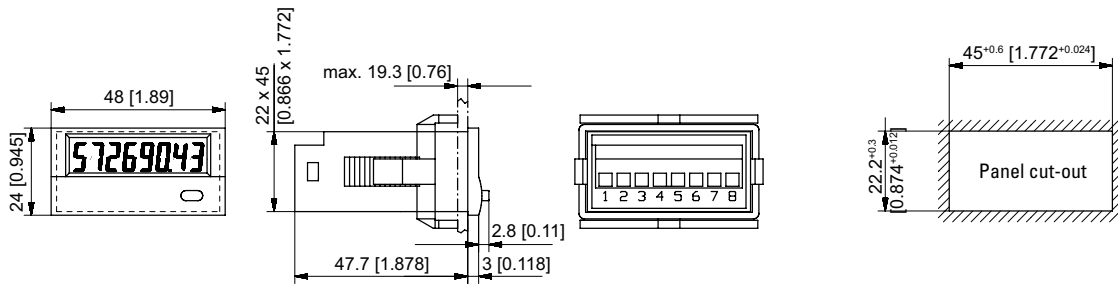

Front bezel for clip mounting (included in delivery)

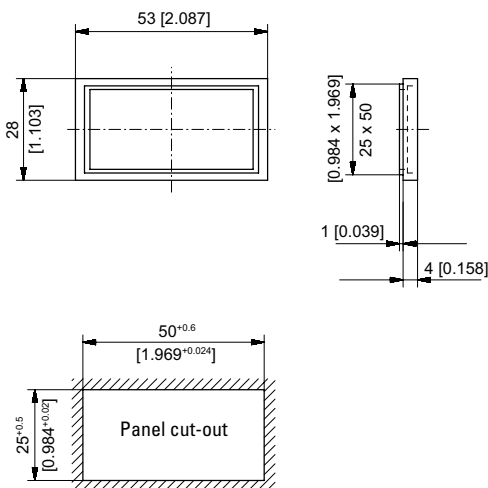

Front bezel for screw mounting (included in delivery)

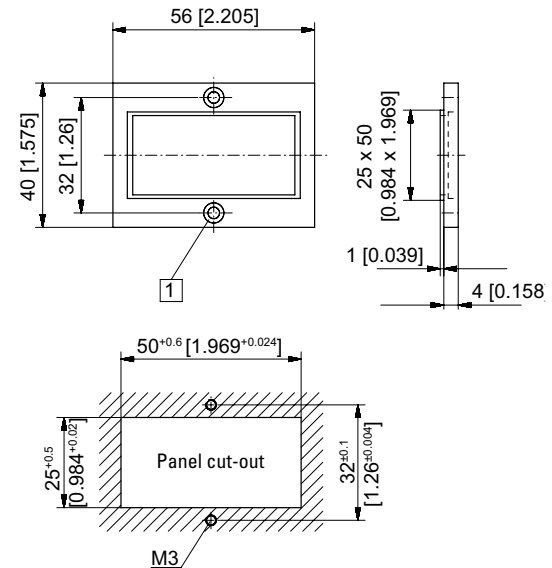

1 Countersinking A f3, DIN 74

LCD pulse counters

With count direction AC (battery)

Codix 132



The Codix 132 is a simple battery powered pulse counter with count and count direction input, 8-digit LCD display, optional backlighting, for high voltage applications 10 ... 260 V AC/DC.

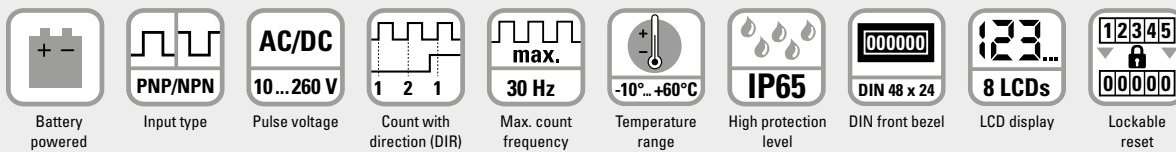

Powerful

- High quality LCD display with 8 mm high figures.
- Count direction adding and subtracting via direction input.
- Battery life approx. 8 years.
- Optional display backlighting.
- Filter function for bounce-free counting with mechanical contacts.
- Count frequency max. 30 Hz.
- High protection level IP65.

Simple

- Screw terminals, RM 5 mm.
- Reset key can be enabled via "Reset Enable" input.
- High voltage version for 10 ... 260 V AC/DC voltage pulses.
- Large 8-digit LCD display with 8 mm high figures.

Order code

6.132 . 012 . 8 X 3
a b

a Backlighting
 5 = without ¹⁾
 6 = with ¹⁾

b Input type: Cnt.Dir ²⁾ – count direction with count and static direction input

Input type	INP A				INP B			
3 ¹⁾ = Cnt.Dir ²⁾	10 ... 260 V AC/DC	direction	AC/DC	30 Hz	10 ... 260 V AC/DC	count	AC/DC	30 Hz

Delivery specification

- Pulse counter
- Mounting clip
- Front bezel for screw mounting (T008181) 56 x 40 mm [2.20 x 1.57"], panel cut-out 50 x 25 mm [1.97 x 0.98"]
- Front bezel for clip mounting (T008180) 53 x 28 mm [2.09 x 1.10"], panel cut-out 50 x 25 mm [1.97 x 0.98"]
- Gasket
- Instruction manual, multilingual

1) Stock types.
 2) Counting input with counting direction input.

Pulse counters, electronic

LCD pulse counters **With count direction AC (battery)** **Codix 132**

Accessories	Dimensions in mm [inch]	Order no.
Adapter front bezel, 72 x 36 [2.83 x 1.42]	for cut-out 68 x 33 [2.68 x 1.30] to cut-out 45 x 22.2 [1.77 x 0.87], for counters 48 x 24 [1.89 x 0.94], as set	black and silver anodised 162704 Set
Adapter front bezel, 48 x 48 [1.89 x 1.89]	for cut-out 45 x 45 [1.77 x 1.77] to cut-out 45 x 22.2 [1.77 x 0.87], with clip mounting for counters 48 x 24 [1.89 x 0.94]	black T008883
Adapter front bezel, 60 x 50 [2.36 x 1.97]	for cut-out 54 x 29 [2.13 x 1.14] to cut-out 45 x 22.2 [1.77 x 0.87], with screw mounting and gasket for counters 48 x 24 [1.89 x 0.94]	black N003001
Transparent cover, lockable, IP65	for cut-out 54 x 29 [2.13 x 1.14], for screw mounting to front bezel F1B or adapter front bezel N003001, for counters with cut-out 50 x 25 [1.97 x 0.98] or 45 x 22.2 [1.77 x 0.87]	N003002
Sealing cover type K1, IP65	suitable for front bezel 60 x 50 [2.36 x 1.97], for screw mounting of electromech. counters and via adapter front bezel N003001 for counters 48 x 24 [1.89 x 0.94]	G008301
Mounting frame with cut-out 50 x 25 [2.36 x 1.97] via separate adapter also for 45 x 22.2 [1.77 x 0.87]	for snap-on mounting on 35 [1.38] top-hat DIN rail, for counters 53 x 28 [2.09 x 1.10] and via separate adapter (T008180) for counters 48 x 24 [1.89 x 0.94]	chromated G300004

Suitable gaskets, other accessories and installation examples for optional accessories can be found in chapter accessories or in the accessories section under: www.kuebler.com/accessories.

Technical data

General technical data	
Display	LCD, 8 digits, 8 mm [0.32"] high
Backlighting	external electrical source 24 V DC $\pm 20\%$, 50 mA
Modes	counting direction (count and direction input) or differential counting
Display range	-9999999 ... 99999999, with overflow display
Reset	manual and electrical
Working temperature	-10°C ... +55°C [+14°F ... +131°F] (non-condensing)
Operating temperature	-10°C ... +60°C [+14°F ... +140°F] (non-condensing)
Storage temperature	-20°C ... +70°C [-4°F ... +158°F]
Altitude	up to 2000 m [6562']

Electrical characteristics	
Power supply	internal lithium battery approx. 8 years at 20°C [68°F]
EMC standards	EN 55011 class B, EN 61000-6-2, EN 61000-6-3
Device safety	designed to protection class application area EN 61010 part 1 2 pollution level 2
UL approval	file E128604

Mechanical characteristics	
Housing	dark grey RAL 7021
Protection	IP65 (front side)
Weight	approx. 50 g [1.76 oz]

Counting inputs

Counting input of the high voltage versions (10 ... 260 V DC/AC)	
counting and direction input	
optocoupler input	max. 30 Hz
minimum pulse time	16 ms
switching level	LOW 0 ... 2 V AC/DC HIGH 10 ... 260 V AC/DC

Reset input

minimum pulse time	DC	50 ms
	high voltage	16 ms
contact input DC – NPN	LOW	0 ... 0.7 VDC
	HIGH	3 ... 30 V DC

Electrical reset key locking

contact input		open collector NPN (switching at 0 V)
switching level – NPN	LOW	0 ... 0.7 V DC
	HIGH	3 ... 5 V DC

Terminal assignment

AC type: 6.132.012.8x3

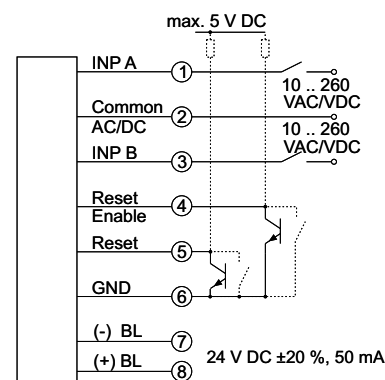

BL = backlighting

Pulse counters, electronic

LCD pulse counters With count direction AC (battery) Codix 132

Dimensions

Dimensions in mm [inch]

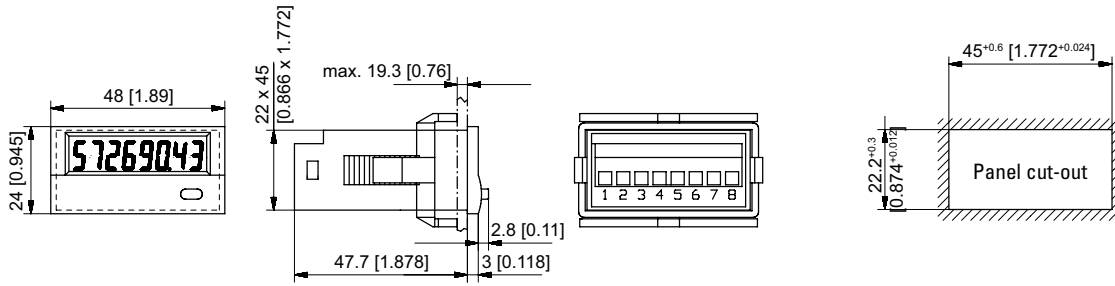

Front bezel for clip mounting (included in delivery)

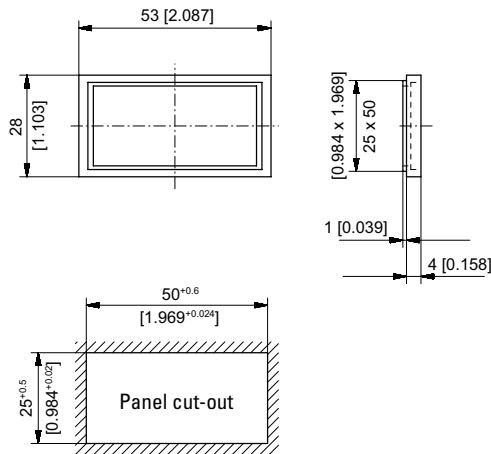

Front bezel for screw mounting (included in delivery)

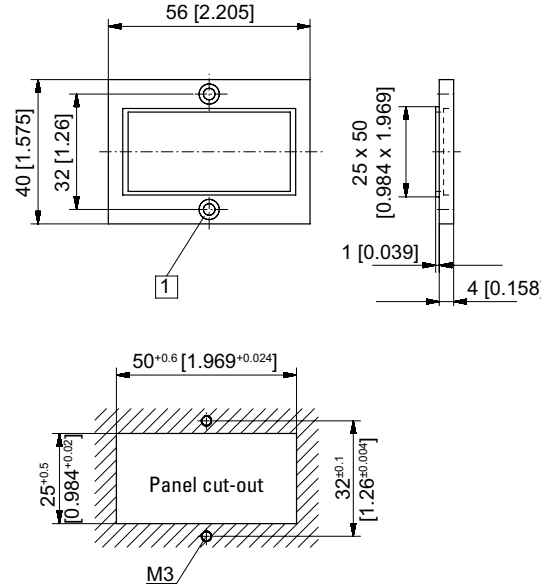

1 Countersinking Af3, DIN 74

Product overview
Basics

Pulse counters

Preset counters

Hour meters
Timers

Frequency displays
Tachometers

Position displays

Multifunction
devices

Energy meters

Process devices

Temperature
devices

Strain-gauge
controllers

Accessories
Index

Pulse counters, electronic

LCD pulse counters Adding counter / service counter (DC) Codix 140 / 142



The Codix 140 / 142 is a simple voltage powered pulse counter for fast and slow count pulses, with 7-digit LCD display for NPN / PNP input signals.
Optional: can be factory pre-programmed.

Codix 140: Standard counter
Codix 142: Service counter



DC 10 ... 30V Power supply	PNP/NPN Input type	max. 8 kHz Max. count frequency	-20°...+65°C Temperature range	IP65 High protection level	000000 DIN front bezel	123... 7 LCDs LCD display	12345 00000 Lockable reset	1 Transistor output (142)
---	------------------------------	--	--	--------------------------------------	----------------------------------	--	---	-------------------------------------

Functional

- Direct display of the total number of pulses.
- Key press displays preset service value and its pre-signal.
- Preset value output as display text and transistor output.
- Pre-signal for the service intervals as display text.
- Manual or electrical reset of the display or of the service intervals.
- Fast PNP or damped NPN control via separate inputs.

User friendly

- Power supply 10 ... 30 V DC.
- Values stored in EEPROM.
- Fixed pre-programmed service intervals e.g. Service at 5000 imp (service)
Pre-signal at 4900 imp (pre-service)
Blinking text message on the display (service or pre-service).
- Multifunction reset key can be enabled via "Reset Enable" input.
- Reset to delivery condition possible.
- Can be factory pre-programmed.

Order code Standard counter 6.140 . 012 . 300 . XXXX ^a

^a Option 1¹⁾, divisor
(If divisor is 1 then omit last 4 digits from code)
0002 ... 4095

Stock types
6.140.012.300

Delivery specification

- Counter
- Mounting clip
- Gaskets
- Instruction manual, multilingual

Order code Service counter 6.142 . 011 . 300 . XXXX ^a . XX ^b . XXXX ^c

^a Option 3¹⁾, service preset
005K = 5000

^b Option 2¹⁾, pre-warning
00 = Pre-warning at 100 before the preset service value, PRESErV and SErVICE

^c Option 1¹⁾, divisor
(If divisor is 1 then omit last 4 digits from code)
0002 ... 4095

Delivery specification

- Counter
- Mounting clip
- Gaskets
- Instruction manual, multilingual

1) The option 1 - 3 can be programmed according to customer needs.
Please note: The min. order quantity for custom versions is 10 pcs with an extra charge, or 200+ pcs with no extra charge.

Pulse counters, electronic

LCD pulse counters	Adding counter / service counter (DC)		Codix 140 / 142
Accessories	Dimensions in mm [inch]		Order no.
Adapter front bezel, 53 x 28 [2.09 x 1.10]	for cut-out 50 x 25 [1.97 x 0.98] to cut-out 45 x 22.2 [1.77 x 0.87], with clip mounting for counters 48 x 24 [1.89 x 0.94]	anthracite	T008180
Adapter front bezel, 56 x 40 [2.20 x 1.57]	for cut-out 50 x 25 [1.97 x 0.98] to cut-out 45 x 22.2 [1.77 x 0.87], with screw mounting for counters 48 x 24 [1.89 x 0.94]	anthracite	T008181
Adapter front bezel, 72 x 36 [2.83 x 1.42]	for cut-out 68 x 33 [2.68 x 1.30] to cut-out 45 x 22.2 [1.77 x 0.87], for counters 48 x 24 [1.89 x 0.94], as set	black and silver anodised	162704 Set
Adapter front bezel, 48 x 48 [1.89 x 1.89]	for cut-out 45 x 45 [1.77 x 1.77] to cut-out 45 x 22.2 [1.77 x 0.87], with clip mounting for counters 48 x 24 [1.89 x 0.94]	black	T008883
Adapter front bezel, 60 x 50 [2.36 x 1.97]	for cut-out 54 x 29 [2.13 x 1.14] to cut-out 45 x 22.2 [1.77 x 0.87], with screw mounting and gasket for counters 48 x 24 [1.89 x 0.94]	black	N003001
Transparent cover, lockable, IP65	for cut-out 54 x 29 [2.13 x 1.14], for screw mounting to front bezel F1B or adapter front bezel N003001, for counters with cut-out 50 x 25 [1.97 x 0.98] or 45 x 22.2 [1.77 x 0.87]		N003002
Sealing cover type K1, IP65	suitable for front bezel 60 x 50 [2.36 x 1.97], for screw mounting of electromech. counters and via adapter front bezel N003001 for counters 48 x 24 [1.89 x 0.94]		G008301
Mounting frame with cut-out 50 x 25 [2.36 x 1.97] via separate adapter also for 45 x 22.2 [1.77 x 0.87]	for snap-on mounting on 35 [1.38] top-hat DIN rail, for counters 53 x 28 [2.09 x 1.10] and via separate adapter (T008180) for counters 48 x 24 [1.89 x 0.94]	chromated	G300004

Suitable gaskets, other accessories and installation examples for optional accessories can be found in chapter accessories or in the accessories section under: www.kuebler.com/accessories.

Technical data

General technical data	
Display	LCD, 7 digits, 8 mm [0.32"] high
Counting range	0 ... 9999999, no decimal point
Data backup	EEPROM
Operating temperature	-20°C ... +65°C [-4°F ... +149°F] (non-condensing)
Storage temperature	-25°C ... +75°C [-13°F ... +167°F]

Electrical characteristics	
Power supply	10 ... 30 V DC, max. 25 mA
Start delay	500 ms
EMC standards	EN 55011 class B, EN 61000-6-2, EN 61000-6-3, EN 61326-1

Mechanical characteristics	
Housing	front panel mount DIN 43700, 48 x 24 mm [1.89 x 0.94"] dark grey Ral 7021
Weight	40 g [1.41 oz]
Protection	IP65 (front side) IP20 (rear side)
Connections	8-pole screw terminals, pitch 5.08 mm [2.00"]
Vibration resistance acc. to EN 60068-2-6	10 ... 55 Hz / 1 mm [0.04"] / 30 min
Shock resistance acc. to EN 60068-2-27	100 G: 2 ms 10 G: 6 ms

Inputs	
Counting input A	fast input, PNP switching (max. 8 kHz)
Counting input B	slow input, NPN switching (mechanical contact, max. 48 Hz)
Reset key enable input	static NPN input
Reset	edge-triggered NPN input (min. 20 ms)
Input resistance	10 kOhm
Switching level	LOW 0 ... 2 V DC HIGH 3.5 ... 30 V DC
Switching threshold	approx. 2.7 V DC
Scaling	1 ... 4095 (factory-set)

Additional data for Codix 142 (service counter)	
Output	NPN transistor output, open collector
Output voltage	max. 30 V DC
Output current	max. 50 mA

Pulse counters, electronic

LCD pulse counters Adding counter / service counter (DC) Codix 140 / 142

Display and inquiry mode - service counter

If the reset key is not released by means of the activation input of pin 6, pressing the key makes the following functions available to the user.

Press 1 x: The text "SERVICE" is displayed

Press 2 x: The following Service value is displayed

Press 3 x: The text "PrESErV" is displayed

Press 4 x: The following pre-service value is displayed

Press 5 x: The current value is displayed

For the service counters, the values counted remain stored, the service values are incremented by the stored preset value when resetting. E.g. service value 5000 pulses, counter count when resetting 5100 pulses, new service value 10100.

Applications

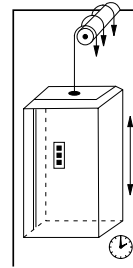

Ride counting and service intervals

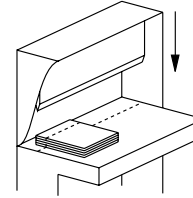

Number of cuts and knife replacement

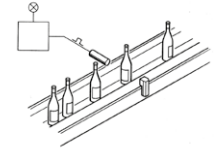

Total quantity and service interval

Terminal assignment

PIN	Description	Standard counter	Service counter
Power supply			
1	+U _B	10 ... 30 V DC	10 ... 30 V DC
2	0 V DC, GND	GND	GND
Inputs			
3	0 V DC, GND	GND	GND
4	Fast counting input	INP PNP	INP PNP
5	Slow counting input	INP NPN	INP NPN
6	Reset enable input	RESET MANUAL ENABLE	RESET MANUAL ENABLE
7	Reset input	RESET	RESET
Output			
8	NPN output	n.c.	OUT

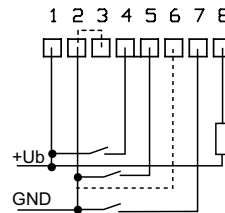

Output 8 is used only with Codix 142 as a NPN output

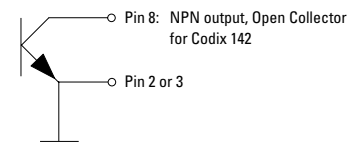

Dimensions

Dimensions in mm [inch]

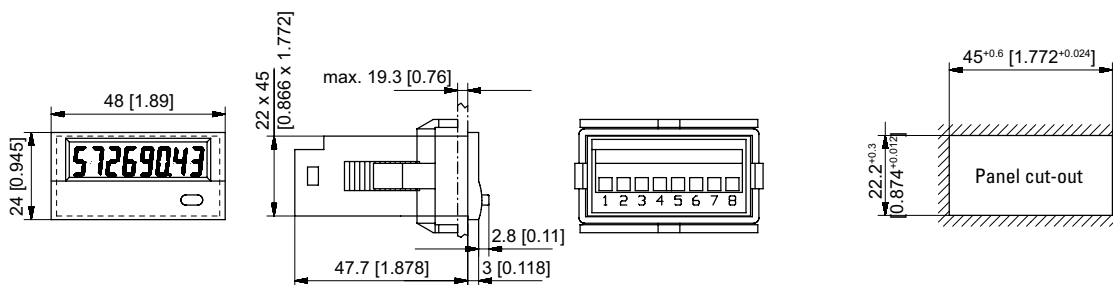

LED pulse counters **Adding (DC)** **Codix 520**



The Codix 520 is a simple voltage powered pulse counter for fast and slow count pulses, with 6-digit LED display, for NPN / PNP input signals.



DC 10 ... 30V Power supply	000000 DIN 48 x 24 DIN front bezel	-20° + 65° Temperature range	IP65 High protection level	PROG Menu-driven programming	GLOVE Operation with gloves	PNP/NPN Input type	max. 60 kHz Pulse counter/ Totalizer
---	---	--	--------------------------------------	--	---------------------------------------	------------------------------	--

Powerful

- Fast count input – input frequency max. 60 kHz.
- Robust housing – IP65 protected.
- Very bright LED display, 8 mm high.
- Simple totalizing and quantity counter
 - single channel count input and reset input.
 - programmable for positive (PNP) or OV (NPN) switching input pulses.
 - fast count input with an input frequency of max. 60 kHz, can be damped to 30 Hz for mechanical contacts.
- Short start-up time – detects input pulses just 16 msec after being switched on => no pulses are lost with a simultaneous motor start-up.

User-friendly

- Large keys – can also be operated when wearing gloves.
- Simple uniform menu-driven programming and operation – possible to enter the programming also during operation with a confirmation prompt.
- Programmable decimal point, can be set from 0.0 to 0.000.
- Manual or electrical reset – tamper-proof due to lockable reset function.
- As an alternative to the HTL inputs, devices are available with a 4 ... 30 V DC input level, for use as parallel displays to PLCs.

Order code

6.520 . 012 . 3X0

a Input switching level
0 = Standard (HTL)¹⁾
A = 4 ... 30 V DC

Delivery specification

- Counter
- Mounting clip
- Front bezel for screw mounting (T008181) 56 x 40 mm [2.20 x 1.57"], panel cut-out 50 x 25 mm [1.97 x 0.98"]
- Front bezel for clip mounting (T008180) 53 x 28 mm [2.09 x 1.10"], panel cut-out 50 x 25 mm [1.97 x 0.98"]
- Gasket
- Instruction manual, multilingual

1) Stock types.

Pulse counters, electronic

LED pulse counters	Adding (DC)	Codix 520
Accessories	Dimensions in mm [inch]	Order no.
Adapter front bezel, 72 x 36 [2.83 x 1.42]	for cut-out 68 x 33 [2.68 x 1.30] to cut-out 45 x 22.2 [1.77 x 0.87], for counters 48 x 24 [1.89 x 0.94], as set	black and silver anodised 162704 Set
Adapter front bezel, 48 x 48 [1.89 x 1.89]	for cut-out 45 x 45 [1.77 x 1.77] to cut-out 45 x 22.2 [1.77 x 0.87], with clip mounting for counters 48 x 24 [1.89 x 0.94]	black T008883
Adapter front bezel, 60 x 50 [2.36 x 1.97]	for cut-out 54 x 29 [2.13 x 1.14] to cut-out 45 x 22.2 [1.77 x 0.87], with screw mounting and gasket for counters 48 x 24 [1.89 x 0.94]	black N003001
Transparent cover, lockable, IP65	for cut-out 54 x 29 [2.13 x 1.14], for screw mounting to front bezel F1B or adapter front bezel N003001, for counters with cut-out 50 x 25 [1.97 x 0.98] or 45 x 22.2 [1.77 x 0.87]	N003002
Sealing cover type K1, IP65	suitable for front bezel 60 x 50 [2.36 x 1.97], for screw mounting of electromech. counters and via adapter front bezel N003001 for counters 48 x 24 [1.89 x 0.94]	G008301
Mounting frame with cut-out 50 x 25 [2.36 x 1.97] via separate adapter also for 45 x 22.2 [1.77 x 0.87]	for snap-on mounting on 35 [1.38] top-hat DIN rail, for counters 53 x 28 [2.09 x 1.10] and via separate adapter (T008180) for counters 48 x 24 [1.89 x 0.94]	chromated G300004

Suitable gaskets, other accessories and installation examples for optional accessories can be found in chapter accessories or in the accessories section under: www.kuebler.com/accessories.

Technical data

General technical data		Electrical characteristics	
Display	6 digits, red 7 segment LED display; 8 mm [0.32"] high	Power supply	10 ... 30 V DC, with integrated reverse polarity protection
Data backup	EEPROM	Current consumption	max. 45 mA
Operating temperature	10 ... 26 V DC -20°C ... +65°C [-4°F ... +149°F] > 26 ... 30 V DC -20°C ... +55°C [-4°F ... +131°F] (non-condensing)	EMC standards	EN 55011 class B, EN 61000-6-2, EN 61000-6-3, EN 61326-1
Storage temperature	-25°C ... +70°C [-13°F ... +158°F]	UL approval	file E128604
Inputs		Mechanical characteristics	
Polarity of inputs	programmable, NPN or PNP for all inputs	Housing	front panel mount 48 x 24 mm [1.89 x 0.94"] acc. to DIN 43700; RAL 7021, dark grey
Input resistance	approx. 5 kΩ	Protection	IP65 (front side)
Counting frequency	max. 60 kHz, can be damped to 30 Hz	Weight	approx. 50 g [1.76 oz]
Minimum pulse duration of the reset input	5 ms	Vibration resistance acc. to EN 60068-2-6	10 ... 55 Hz / 1 mm [0.04"] / 30 min
Input switching level (HTL)	LOW 0 ... 0.2 x U _B (V DC) HIGH 0.6 x U _B ... 30 V DC	Shock resistance acc. to EN 60068-2-27	100 G: 2 ms 10 G: 6 ms
Input switching level at 4 ... 30 V DC	LOW 0 ... 2 V DC HIGH 4 ... 30 V DC		

Applications for pulse counters / totalizers

- Simple count tasks such as quantity and piece counting
- Accessories, OEM equipment or retrofitting to production machines
- Piece counting on die cutters, presses, extruders, woodworking machines, drilling machines, pick-and-place machines, guillotines, special-purpose vehicles etc.

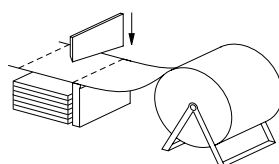

Piece-counting

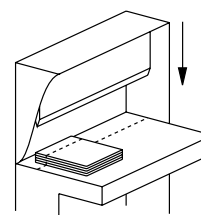

Number of cuts

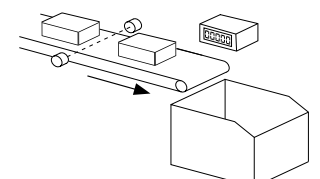

Piece-counting on conveyor

LED pulse counters

Adding (DC)

Codix 520

Block diagram

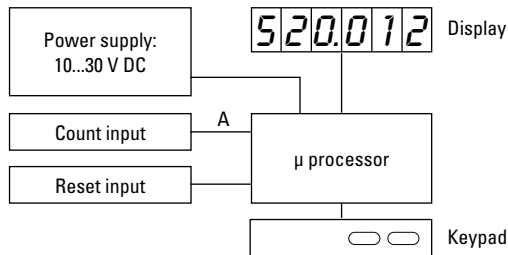

Terminal assignment



PIN	without optocoupler
1	10 ... 30 V DC
2	0 V GND
3	INP
4	–
5	Reset

Dimensions

Dimensions in mm [inch]

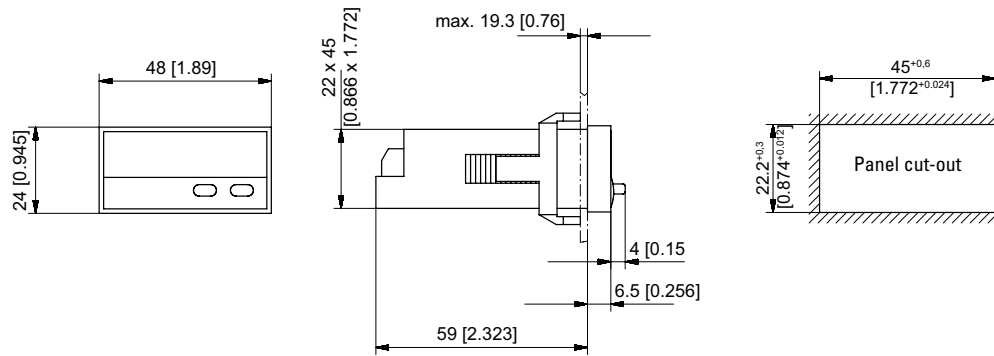

Front bezel for clip mounting (included in delivery)

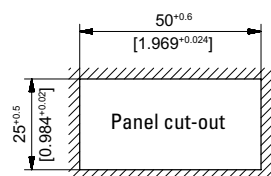
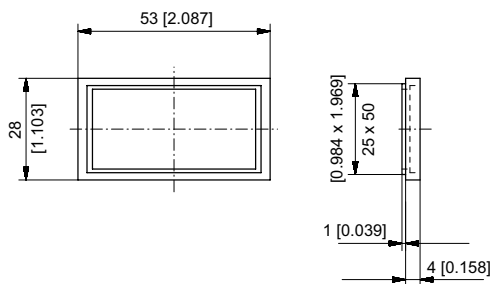

Front bezel for screw mounting (included in delivery)

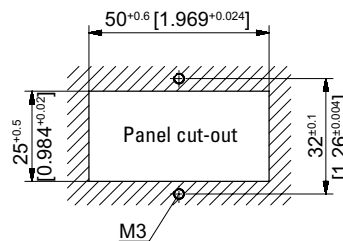
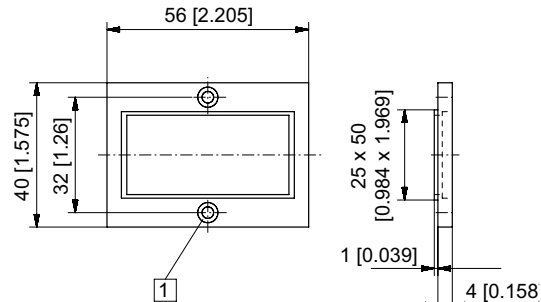

1 Countersinking Af3, DIN 74

LED pulse counters **6 count modes (DC)** **Codix 521**



The Codix 521 is a voltage powered pulse counter / position display for fast and slow count pulses, with 6-digit LED display for NPN, PNP input signals.

Equipped with 4 count input modes: count direction, difference, addition, quadrature (phase discriminator) x1, x2 and x4.



Product overview
Basics
Pulse counters
Preset counters
Hour meters
Timers
Frequency displays
Tachometers
Position displays
Multifunction devices
Energy meters
Process devices
Temperature devices
Strain-gauge controllers
Accessories
Index

DC 10 ... 30V Power supply	 DIN 48 x 24 DIN front bezel	 - 20° + 65° Temperature range	 IP65 High protection level	 Menu-driven programming	 max. 60 kHz Pulse counter/Totalizer	 POSITION Position display	 1 2 1 Count with direction (DIR)	 1 2 1 Differential count (up.dn)	 1 3 4 Add/Add count (up.up)	 1 1 2 3 4 Phase discriminator
---	------------------------------------	--------------------------------------	-----------------------------------	-----------------------------	---	----------------------------------	---	---	------------------------------------	--------------------------------------

Powerful

- Fast count input – input frequency max. 60 kHz.
- Robust housing – IP65 protected.
- Very bright LED display, 8 mm high.
- Position, difference, adding or count direction detection
 - programmable for positive (PNP) or OV (NPN) switching input pulses.
 - fast count input with an input frequency of max. 60 kHz, can be damped to 30 Hz for mechanical contacts.
- Short start-up time – detects input pulses just 16 msec after being switched on => no pulses are lost with a simultaneous motor start-up.

User-friendly

- Large keys – can also be operated when wearing gloves.
- Simple uniform menu-driven programming and operation – possible to enter the programming also during operation with a confirmation prompt.
- Individually programmable scaling: Multiplication and division factor (0.0001...99.9999), to display corresponding engineering units, e.g. position in 1/10 mm or packing units.
- 4 different count input modes: 2-channel count input for detecting count direction, difference or adding mode, quadrature with x1, x2 or x4 evaluation.
- Freely programmable setpoint.
- As an alternative to the HTL inputs, devices are available with a 4 ... 30 V DC input level, for use as parallel displays to PLCs.
- Optional output - as zero signal.

Order code 6.521 . 01 X . 3 X 0

- a** Output
1 = optocoupler output
2 = no output ¹⁾
- b** Input switching level
0 = Standard (HTL) ¹⁾
A = 4 ... 30 V DC

- Delivery specification**
- Counter
 - Mounting clip
 - Front bezel for screw mounting (T008181) 56 x 40 mm [2.20 x 1.57"], panel cut-out 50 x 25 mm [1.97 x 0.98"]
 - Front bezel for clip mounting (T008180) 53 x 28 mm [2.09 x 1.10"], panel cut-out 50 x 25 mm [1.97 x 0.98"]
 - Gasket
 - Instruction manual, multilingual

1) Stock types.

Pulse counters, electronic

LED pulse counters 6 count modes (DC) Codix 521

Accessories	Dimensions in mm [inch]	Order no.
Adapter front bezel, 72 x 36 [2.83 x 1.42]	for cut-out 68 x 33 [2.68 x 1.30] to cut-out 45 x 22.2 [1.77 x 0.87], for counters 48 x 24 [1.89 x 0.94], as set black and silver anodised	162704 Set
Adapter front bezel, 48 x 48 [1.89 x 1.89]	for cut-out 45 x 45 [1.77 x 1.77] to cut-out 45 x 22.2 [1.77 x 0.87], with clip mounting for counters 48 x 24 [1.89 x 0.94] black	T008883
Adapter front bezel, 60 x 50 [2.36 x 1.97]	for cut-out 54 x 29 [2.13 x 1.14] to cut-out 45 x 22.2 [1.77 x 0.87], with screw mounting and gasket for counters 48 x 24 [1.89 x 0.94] black	N003001
Transparent cover, lockable, IP65	for cut-out 54 x 29 [2.13 x 1.14], for screw mounting to front bezel F1B or adapter front bezel N003001, for counters with cut-out 50 x 25 [1.97 x 0.98] or 45 x 22.2 [1.77 x 0.87]	N003002
Sealing cover type K1, IP65	suitable for front bezel 60 x 50 [2.36 x 1.97], for screw mounting of electromech. counters and via adapter front bezel N003001 for counters 48 x 24 [1.89 x 0.94]	G008301
Mounting frame with cut-out 50 x 25 [2.36 x 1.97] via separate adapter also for 45 x 22.2 [1.77 x 0.87]	for snap-on mounting on 35 [1.38] top-hat DIN rail, for counters 53 x 28 [2.09 x 1.10] and via separate adapter (T008180) for counters 48 x 24 [1.89 x 0.94] chromated	G300004

Suitable gaskets, other accessories and installation examples for optional accessories can be found in chapter accessories or in the accessories section under: www.kuebler.com/accessories.

Technical data

General technical data	
Display	6 digits, red 7 segment LED display; 8 mm [0.32"] high
Data backup	EEPROM
Operating temperature	10 ... 26 V DC -20°C ... +65°C [-4°F ... +149°F] > 26 ... 30 V DC -20°C ... +55°C [-4°F ... +131°F] (non-condensing)
Storage temperature	-25°C ... +70°C [-13°F ... +158°F]
Inputs	
Polarity of inputs	programmable, NPN or PNP for all inputs
Input resistance	approx. 5 kΩ
Counting frequency	max. 60 kHz, can be damped to 30 Hz; for position display max. 25 kHz
Minimum pulse duration of the reset input	5 ms
Input switching level (HTL)	LOW 0 ... 0.2 x U _B (V DC) HIGH 0.6 x U _B ... 30 V DC
Input switching level at 4 ... 30 V DC	LOW 0 ... 2 V DC HIGH 4 ... 30 V DC

Electrical characteristics	
Power supply	10 ... 30 V DC, with reverse polarity protection
Current consumption	max. 55 mA
EMC standards	EN 55011 class B, EN 61000-6-2, EN 61000-6-3, EN 61326-1
UL approval	file E128604
Mechanical characteristics	
Housing	front panel mount 48x24 mm [1.89 x 0.94"] acc. to DIN 43700; RAL 7021, dark grey
Protection	IP65 (front side)
Weight	approx. 50 g [1.76 oz]
Vibration resistance acc. to EN 60068-2-6	10 ... 55 Hz / 1 mm [0.04"] / 30 min
Shock resistance acc. to EN 60068-2-27	100 G: 2 ms 10 G: 6 ms
Outputs (optional)	
Optocoupler output	max. 30 V DC, 10 mA

Applications for position displays / totalizers

- Positioning tasks on processing machines, such as sawing machines, milling machines, bending and folding machines, etc.
- Production data acquisition by means of piece counting (using difference or adding)
- Totalizing flow, quantity and other scalable media
- Counting tasks such as quantity and piece counting
- Accessories, OEM equipment or retrofitting to production machines
- Piece counting on die cutters, presses, extruders, woodworking machines, drilling machines, pick-and-place machines, guillotines, special-purpose vehicles etc.

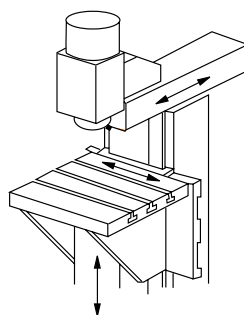

Position on milling machine

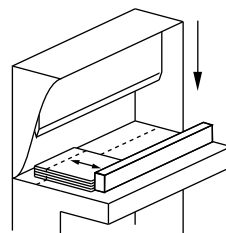

Position or quantity

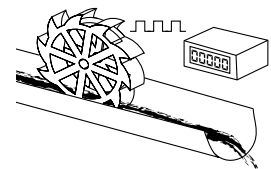

Flow rate

Pulse counters, electronic

LED pulse counters 6 count modes (DC) Codix 521

Block diagram

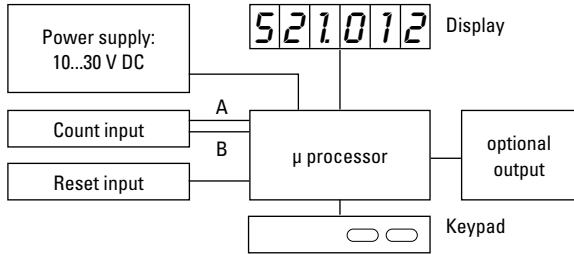

Terminal assignment

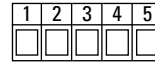

PIN	without optocoupler
1	10 ... 30 V DC
2	0 V GND
3	INP A
4	INP B
5	Reset

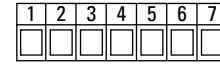

PIN	with optocoupler (NPN)
1	10 ... 30 V DC
2	0 V GND
3	INP A
4	INP B
5	Reset
6	Emitter
7	Collector

Dimensions

Dimensions in mm [inch]

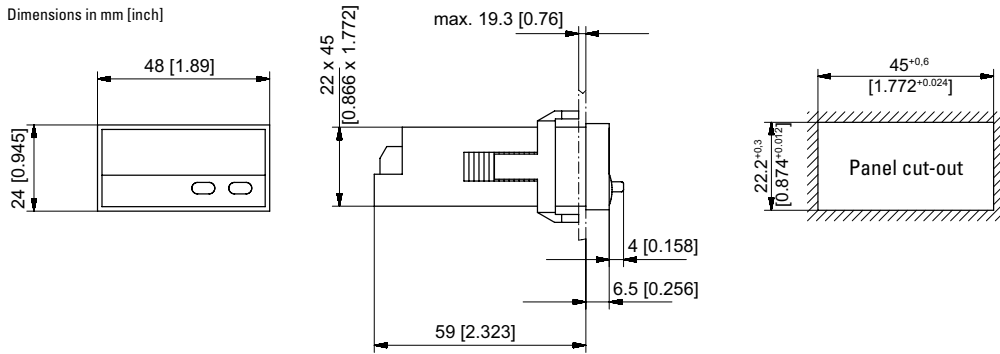

Front bezel for clip mounting (included in delivery)

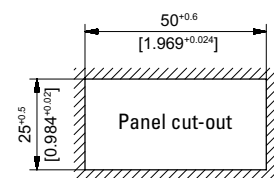
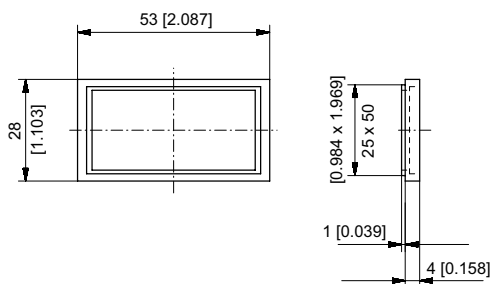

Front bezel for screw mounting (included in delivery)

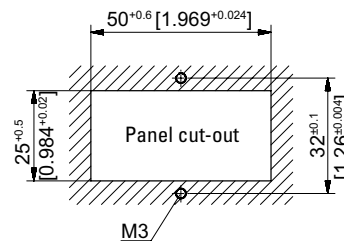
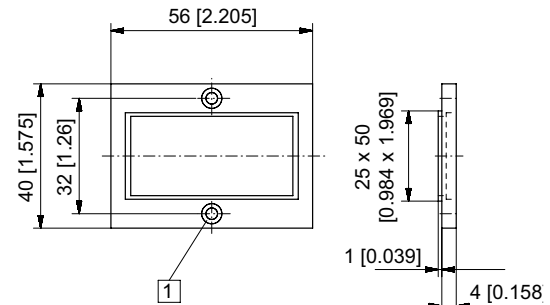

1 Countersinking Af3, DIN 74

LED pulse counters

2 counters with separate scaling (DC)

Codix 52T



The Codix 52T is a voltage powered dual pulse counter with a common input and separate scaling, for fast and slow count pulses, with 6-digit LED display for NPN, PNP input signals and display switching between A and B.



Power supply



DIN front bezel

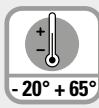

Temperature range



High protection level



Menu-driven programming



Operation with gloves

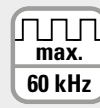

Pulse counter/Totalizer



Input type

Powerful

- Fast count input – input frequency max. 60 kHz.
- Robust housing – IP65 protected.
- Very bright LED display, 8 mm high.
- Single channel dual totalizer
 - programmable for positive (PNP) or OV (NPN) switching input pulses.
 - fast count inputs with an input frequency of max. 60 kHz, can be damped to 30 Hz for mechanical contacts.
- Short start-up time – detects input pulses just 16 msec after being switched on => no pulses are lost with a simultaneous motor start-up.

User-friendly and universal

- Large keys – can also be operated when wearing gloves.
- Simple uniform menu-driven programming and operation – possible to enter the programming also during operation with a confirmation prompt.
- Individually programmable scaling for both counters multiplication and division factor (0.0001...99.9999), to display corresponding units in, for example, litres, length or packaging size.
- Simple display switching between counters 1 and 2.
- DC power supply.
- As an alternative to the HTL units, models are also available with a fixed signal level threshold >4 V DC for use with TTL signals.
- Reset manual or electrical, programmable separately for both counters (the reset can also be locked out).

Order code

6.52T . 012 . 3X0^a

^a Input switching level

0 = Standard (HTL)

A = Fixed level

LOW 0 ... 2 V DC

HIGH 4 ... 30 V DC

Delivery specification

- Counter
- Mounting clip
- Front bezel for screw mounting (T008181) 56 x 40 mm [2.20 x 1.57"], panel cut-out 50 x 25 mm [1.97 x 0.98"]
- Front bezel for clip mounting (T008180) 53 x 28 mm [2.09 x 1.10"], panel cut-out 50 x 25 mm [1.97 x 0.98"]
- Gasket
- Instruction manual, multilingual

Pulse counters, electronic

LED pulse counters 2 counters with separate scaling (DC) Codix 52T

Accessories	Dimensions in mm [inch]	Order no.
Adapter front bezel, 72 x 36 [2.83 x 1.42]	for cut-out 68 x 33 [2.68 x 1.30] to cut-out 45 x 22.2 [1.77 x 0.87], for counters 48 x 24 [1.89 x 0.94], as set black and silver anodised	162704 Set
Adapter front bezel, 48 x 48 [1.89 x 1.89]	for cut-out 45 x 45 [1.77 x 1.77] to cut-out 45 x 22.2 [1.77 x 0.87], with clip mounting for counters 48 x 24 [1.89 x 0.94] black	T008883
Adapter front bezel, 60 x 50 [2.36 x 1.97]	for cut-out 54 x 29 [2.13 x 1.14] to cut-out 45 x 22.2 [1.77 x 0.87], with screw mounting and gasket for counters 48 x 24 [1.89 x 0.94] black	N003001
Transparent cover, lockable, IP65	for cut-out 54 x 29 [2.13 x 1.14], for screw mounting to front bezel F1B or adapter front bezel N003001, for counters with cut-out 50 x 25 [1.97 x 0.98] or 45 x 22.2 [1.77 x 0.87]	N003002
Sealing cover type K1, IP65	suitable for front bezel 60 x 50 [2.36 x 1.97], for screw mounting of electromech. counters and via adapter front bezel N003001 for counters 48 x 24 [1.89 x 0.94]	G008301
Mounting frame with cut-out 50 x 25 [2.36 x 1.97] via separate adapter also for 45 x 22.2 [1.77 x 0.87]	for snap-on mounting on 35 [1.38] top-hat DIN rail, for counters 53 x 28 [2.09 x 1.10] and via separate adapter (T008180) for counters 48 x 24 [1.89 x 0.94] chromated	G300004

Suitable gaskets, other accessories and installation examples for optional accessories can be found in chapter accessories or in the accessories section under: www.kuebler.com/accessories.

Technical data

General technical data	
Display	6 digits, red 7 segment LED display; 8 mm [0.32"] high
Data backup	EEPROM
Operating temperature	10 ... 26 V DC -20°C ... +65°C [-4°F ... +149°F] > 26 ... 30 V DC -20°C ... +55°C [-4°F ... +131°F] (non-condensing)
Storage temperature	-25°C ... +70°C [-13°F ... +158°F]

Inputs	
Polarity of inputs	programmable, NPN or PNP for all inputs
Input resistance	approx. 5 kΩ
Counting frequency	max. 60 kHz, can be damped to 30 Hz
Minimum pulse duration of the reset input	5 ms
Input switching level (HTL)	LOW 0 ... 0.2 x U _B (V DC) HIGH 0.6 x U _B ... 30 V DC
Input switching level at 4 ... 30 V DC	LOW 0 ... 2 V DC HIGH 4 ... 30 V DC

Electrical characteristics	
Power supply	10 ... 30 V DC, with integrated reverse polarity protection
Current consumption	max. 40 mA
EMC standards	EN 55011 class B, EN 61000-6-2, EN 61000-6-3, EN 61326-1
UL approval	file E128604

Mechanical characteristics	
Housing	front panel mount 48x24mm [1.89 x 0.94"] acc. to DIN 43700; RAL 7021, dark grey
Protection	IP65 (front side)
Weight	approx. 50 g [1.76 oz]
Vibration resistance acc. to EN 60068-2-6	10 ... 55 Hz / 1 mm [0.04"] / 30 min
Shock resistance acc. to EN 60068-2-27	100 G: 2 ms 10 G: 6 ms

Application examples for the dual totalizer

- Logging of piece count and overall total
- Totalizing of flow volumes, quantities and other scalable media
- Counting tasks, such as quantities and piece counting
- Accessories, OEM or retrofit equipment for production machinery
- Piece counting on die-cutters, presses, extruders, wood-processing machines, drilling machines, pick-and-place machines, guillotines, special vehicles
- Measurement of two different values in just one device: e.g. with 2 inputs both the piece count and the number of packages can be counted
- Recording of the total results from 2 work-shifts

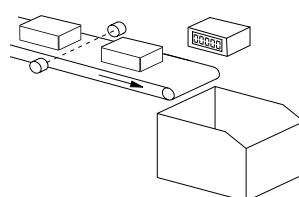

Total piece count as well as packing units

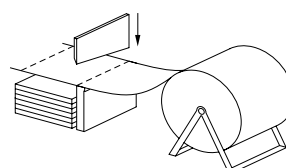

Individual and total quantities

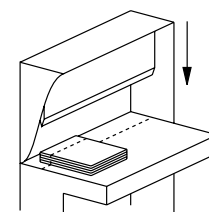

Individual and total quantity from 2 work-shifts

Pulse counters, electronic

LED pulse counters 2 counters with separate scaling (DC) Codix 52T

Block diagram

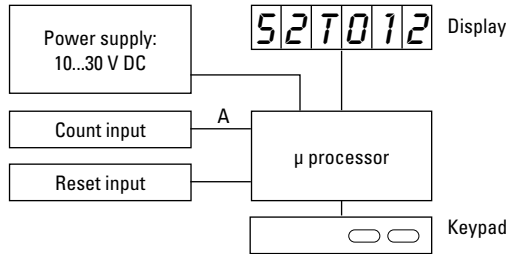

Terminal assignment

1	2	3	4	5
PIN				
1	10 ... 30 V DC			
2	0 V GND			
3	INP A			
4	-			
5	Reset			

Dimensions

Dimensions in mm [inch]

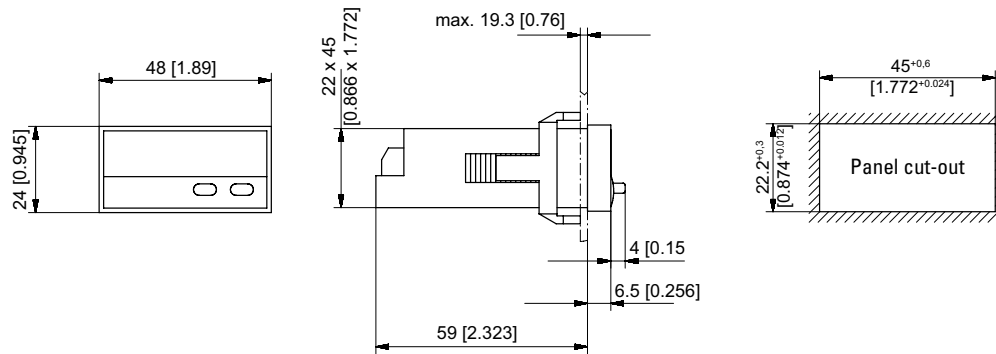

Front bezel for clip mounting (included in delivery)

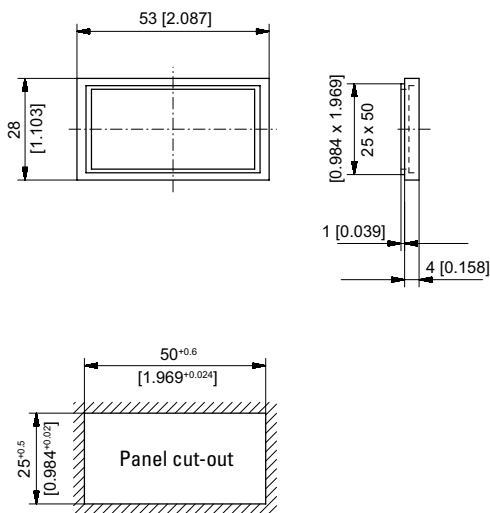

Front bezel for screw mounting (included in delivery)

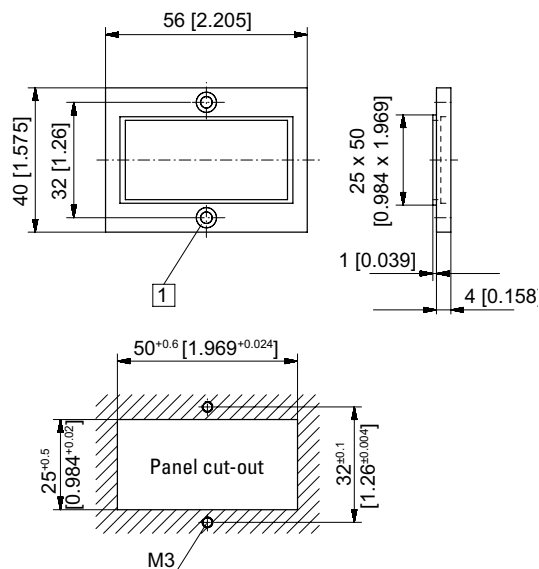

1 Countersinking Af3, DIN 74

Product overview
Basics

Pulse counters

Preset counters

Hour meters
Timers

Frequency displays
Tachometers

Position displays

Multifunction
devices

Energy meters

Process devices

Temperature
devices

Strain-gauge
controllers

Accessories
Index

LED pulse counters **2 counters with separate inputs and separate scaling (DC)** **Codix 52C**



The Codix 52C is a voltage powered dual pulse counter with separate inputs and separate scaling, for fast and slow count pulses, with 6-digit LED display for NPN, PNP input signals and display switching between A, B, A-B, A+B, A/B, (A-B)/A [%].



DC 10 ... 30V Power supply	000000 DIN 48 x 24 DIN front bezel	-20... +65°C Temperature range	IP65 High protection level	PROG Menu-driven programming	max. 25 kHz Pulse counter/ Totalizer	PNP/NPN Input type
---	---	--	--------------------------------------	--	---	------------------------------

Powerful

- Single channel dual totalizer with 2 separate inputs
 - programmable for positive (PNP) or 0V (NPN) switching input pulses
 - fast count inputs with an input frequency of max. 25 kHz. Can be damped to 30 Hz for mechanical contacts.
- Robust housing – IP65 protected.
- Very bright LED display, 8 mm high.
- Short start-up time – detects input pulses just 16 msec after being switched on => no pulses are lost with a simultaneous motor start-up.

User-friendly and universal

- Large keys – can also be operated when wearing gloves.
- Simple uniform menu-driven programming and operation – possible to enter the programming also during operation with a confirmation prompt.
- Individually programmable scaling for inputs A and B multiplication and division factor (0.0001...99.9999), to display corresponding units in, for example, litres, length or packaging size.
- Simple display switching from A to B or A+B, A-B, A/B, (A-B)/A [%].
- DC power supply.
- As an alternative to the HTL units, models are also available with a fixed signal level threshold >4 ... 30 V DC for use with TTL signals.
- Reset manual or electrical, programmable separately for both counters (the reset can also be locked out).

Order code

6.52C . 012 . 3X0^a

a Input switching level
 0 = Standard (HTL)
 A = 4 ... 30 V DC
 LOW 0 ... 2 V DC
 HIGH 4 ... 30 V DC

Delivery specification

- Counter
- Mounting clip
- Front bezel for screw mounting (T008181) 56 x 40 mm [2.20 x 1.57"], panel cut-out 50 x 25 mm [1.97 x 0.98"]
- Front bezel for clip mounting (T008180) 53 x 28 mm [2.09 x 1.10"], panel cut-out 50 x 25 mm [1.97 x 0.98"]
- Gasket
- Instruction manual, multilingual

Product overview
Basics

Pulse counters

Preset counters

Hour meters
Timers

Frequency displays
Tachometers

Position displays

Multifunction devices

Energy meters

Process devices

Temperature devices

Strain-gauge controllers

Accessories
Index

Pulse counters, electronic

LED pulse counters 2 counters with separate inputs and separate scaling (DC) Codix 52C

Accessories	Dimensions in mm [inch]	Order no.
Adapter front bezel, 72 x 36 [2.83 x 1.42]	for cut-out 68 x 33 [2.68 x 1.30] to cut-out 45 x 22.2 [1.77 x 0.87], for counters 48 x 24 [1.89 x 0.94], as set black and silver anodised	162704 Set
Adapter front bezel, 48 x 48 [1.89 x 1.89]	for cut-out 45 x 45 [1.77 x 1.77] to cut-out 45 x 22.2 [1.77 x 0.87], with clip mounting for counters 48 x 24 [1.89 x 0.94] black	T008883
Adapter front bezel, 60 x 50 [2.36 x 1.97]	for cut-out 54 x 29 [2.13 x 1.14] to cut-out 45 x 22.2 [1.77 x 0.87], with screw mounting and gasket for counters 48 x 24 [1.89 x 0.94] black	N003001
Transparent cover, lockable, IP65	for cut-out 54 x 29 [2.13 x 1.14], for screw mounting to front bezel F1B or adapter front bezel N003001, for counters with cut-out 50 x 25 [1.97 x 0.98] or 45 x 22.2 [1.77 x 0.87]	N003002
Sealing cover type K1, IP65	suitable for front bezel 60 x 50 [2.36 x 1.97], for screw mounting of electromech. counters and via adapter front bezel N003001 for counters 48 x 24 [1.89 x 0.94]	G008301
Mounting frame with cut-out 50 x 25 [2.36 x 1.97] via separate adapter also for 45 x 22.2 [1.77 x 0.87]	for snap-on mounting on 35 [1.38] top-hat DIN rail, for counters 53 x 28 [2.09 x 1.10] and via separate adapter (T008180) for counters 48 x 24 [1.89 x 0.94] chromated	G300004

Suitable gaskets, other accessories and installation examples for optional accessories can be found in chapter accessories or in the accessories section under: www.kuebler.com/accessories.

Technical data

General technical data	
Display	6 digits, red 7 segment LED display; 8 mm [0.32"] high
Data backup	EEPROM
Operating temperature	10 ... 26 V DC -20°C ... +65°C [-4°F ... +149°F] > 26 ... 30 V DC -20°C ... +55°C [-4°F ... +131°F] (non-condensing)
Storage temperature	-25°C ... +70°C [-13°F ... +158°F]

Inputs	
Polarity of inputs	programmable, NPN or PNP for all inputs
Input resistance	approx. 5 kΩ
Counting frequency	max. 25 kHz, can be damped to 30 Hz
Minimum pulse duration of the reset input	5 ms
Input switching level standard version (HTL)	LOW 0 ... 0.2 x U _B (V DC) HIGH 0.6 x U _B ... 30 V DC
Input switching level at 4 ... 30 V DC	LOW 0 ... 2 V DC HIGH 4 ... 30 V DC

Electrical characteristics	
Power supply	10 ... 30 V DC, with reverse polarity protection
Current consumption	max. 40 mA
EMC standards	EN 55011 class B, EN 61000-6-2, EN 61000-6-3, EN 61326-1
UL approval	file E128604

Mechanical characteristics	
Housing	front panel mount 48 x 24 mm [1.89 x 0.94"] acc. to DIN 43700; RAL 7021, dark grey
Protection	IP65 (front side)
Weight	approx. 50 g [1.76 oz]
Vibration resistance acc. to EN 60068-2-6	10 ... 55 Hz / 1 mm [0.04"] / 30 min
Shock resistance acc. to EN 60068-2-27	100 G: 2 ms 10 G: 6 ms

Application examples for the dual totalizer with separate inputs

- Logging of piece count and overall total
- Totalizing of flow volumes, quantities and other scalable
- Counting tasks, such as quantities and piece counting
- Accessories, OEM or retrofit equipment for production machinery
- Piece counting on die-cutters, presses, extruders, wood-processing machines, drilling machines, pick-and-place machines, guillotines, special vehicles
- Measurement of two different values in just one device: e.g. with 2 inputs both the piece count and the number of packages can be counted
- Recording of the total results from 2 work-shifts

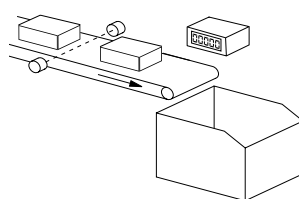

Total piece count as well as packing units

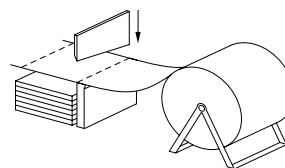

Individual and total quantities

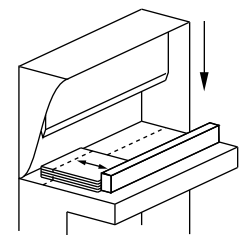

Individual and total quantity from 2 work-shifts

Pulse counters, electronic

LED pulse counters 2 counters with separate inputs and separate scaling (DC) Codix 52C

Block diagram

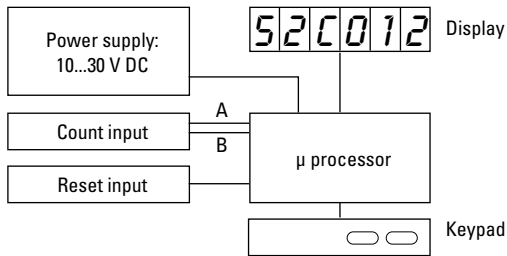

Terminal assignment

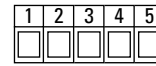

PIN	
1	10 ... 30 V DC
2	0 V GND
3	INP A
4	INP B
5	Reset

Dimensions

Dimensions in mm [inch]

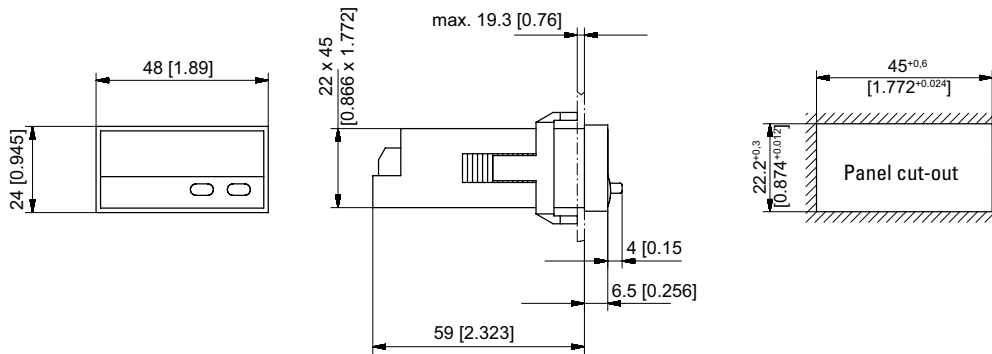

Front bezel for clip mounting (included in delivery)

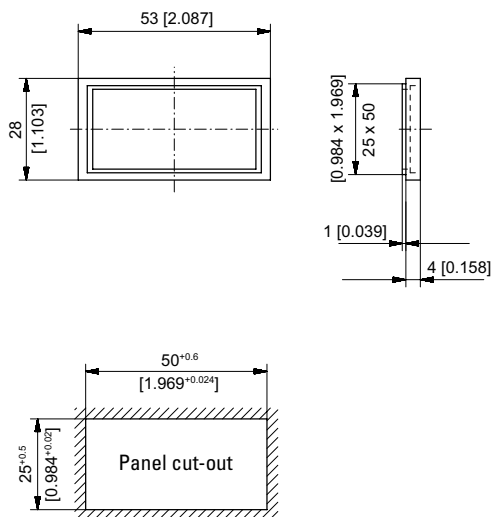

Front bezel for screw mounting (included in delivery)

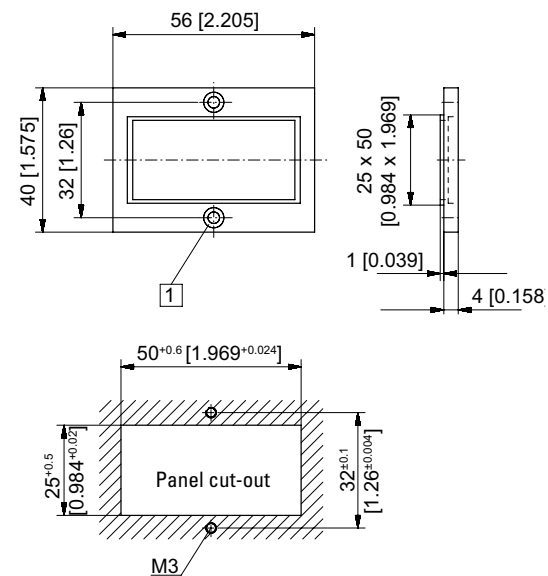

1 Countersinking Af3, DIN 74

LED pulse counters **Adding (AC+DC)** **Codix 540**



The Codix 540 is a simple voltage powered pulse counter for fast and slow count pulses, with 6-digit LED display for NPN, PNP input signals.



DC 10 ... 30 V Power supply	AC 100 ... 240 V Power supply	000000 DIN 96 x 48 DIN front bezel	-20° + 65° Temperature range	IP65 High protection level	Plug-in screw terminal	Menu-driven programming	Operation with gloves	max. 60 kHz Pulse counter/ Totalizer	PNP/NPN Input type
--	--	---	--	--------------------------------------	-------------------------------	--------------------------------	------------------------------	--	------------------------------

Powerful

- Fast count input – input frequency max. 60 kHz
- Robust housing – IP65 protected
- Very bright LED display, 14 mm high
- Simple totalizing and quantity counter
 - single channel count input and reset input
 - programmable for positive (PNP) or OV (NPN) switching input pulses
 - fast count input with an input frequency of max. 60 kHz, can be damped to 30 Hz for mechanical contacts
- Short start-up time – detects input pulses just 16 msec after being switched on => no pulses are lost with a simultaneous motor start-up

User-friendly and universal

- Large keys – can also be operated when wearing gloves
- Simple uniform menu-driven programming and operation – possible to enter the programming also during operation with a confirmation prompt
- Programmable decimal point, can be set from 0.0 to 0.000
- Manual or electrical reset – tamper-proof due to lockable reset function
- AC or DC power supply with sensor power supply
- As an alternative to the HTL inputs, devices are available with a 4 ... 30 V DC input level, for use as parallel displays to PLCs

Order code

6.540 . 012 . XX0

a Power supply 0 = 100 ... 240 V AC, ±10 % ¹⁾ 3 = 10 ... 30 V DC ¹⁾	b Input switching level 0 = Standard (HTL) ¹⁾ A = 4 ... 30 V DC	Delivery specification • Digital display • Mounting clip • Gasket • Instruction manual, multilingual • 2 screw terminals	Replacement parts 7 pin screw terminal RM 3.81 1 ... 7: N100387 2 pin screw terminal RM 5.08 1 ... 2: N100133
--	---	--	--

Accessories	Dimensions in mm [inch]	Order no.
Mounting frame with cut-out 92 x 45 [3.62 x 1.77]	for snap-on mounting on 35 [1.38] top-hat DIN rail, for counters 96 x 48 [3.74 x 1.89]	grey G300005

Suitable gaskets as well as further accessories can be found in the accessories section or in the accessories area of our website at: www.kuebler.com/accessories.

1) Stock types.

Pulse counters, electronic

LED pulse counters Adding (AC+DC) Codix 540

Technical data

General technical data	
Display	6 digit, red 7 segment LED display; 14 mm [0.55"] high
Data backup	EEPROM
Operating temperature	-20°C ... +65°C [-4°F ... +149°F] (non-condensing)
Storage temperature	-25°C ... +70°C [-13°F ... +158°F]
Altitude	up to 2000 m [6562']

Electrical characteristics	
Power supply	10 ... 30 VDC, with reverse polarity protection 100 ... 240 V AC, ±10 %
Current consumption	max. 50 mA, 6 VA
EMC standards	EN 55011 class B, EN 61000-6-2, EN 61000-6-3
Device safety	designed to protection class 2 application area EN 61010 part 1 pollution level 2
UL approval	file E128604

Mechanical characteristics	
Housing	front panel mount 96 x 48 mm [3.74 x 1.89"] acc. to DIN 43700; RAL 7021, dark grey
Protection	IP65 (front side)
Weight	approx. 150 g [5.29 oz]

Inputs	
Polarity of inputs	programmable, NPN or PNP for all inputs
Input resistance	approx. 5 kΩ
Counting frequency ¹⁾	max. 60 kHz, can be damped to 30 Hz
Minimum pulse duration of the reset input	5 ms
Input switching level standard version (HTL)	
DC power supply	LOW 0 ... 0.2 x U _B (V DC)
	HIGH 0.6 x U _B ... 30 V DC
AC power supply	LOW 0 ... 4 V DC
	HIGH 12 ... 30 V DC
Input switching level at 4 ... 30 V DC	
LOW	0 ... 2 V DC
HIGH	4 ... 30 V DC

Outputs	
Voltage output for sensors (AC version)	24 V DC ±15 %/100 mA

Applications for pulse counters / totalizers

- Simple count tasks such as quantity and piece counting
- Accessories, OEM equipment or retrofitting to production machines
- Piece counting on die cutters, presses, extruders, woodworking machines, drilling machines, pick-and-place machines, guillotines, special-purpose vehicles etc.

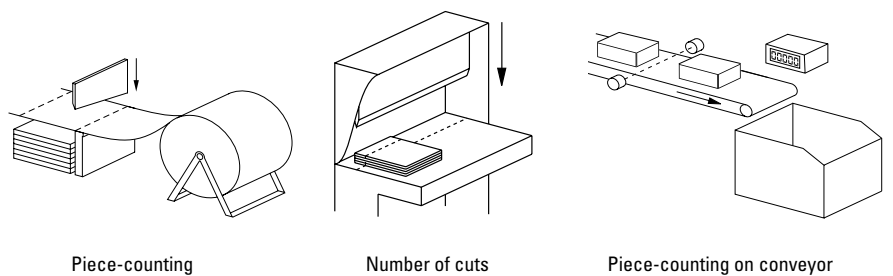

Block diagram

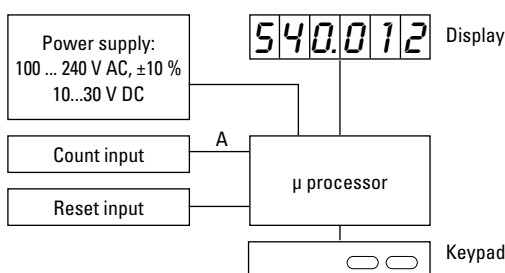

Terminal assignment

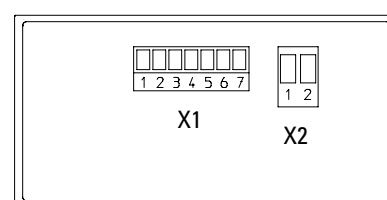

Connection X1

PIN	AC version	DC version
1	n.c	
2	n.c	
3	Reset	
4	n.c	
5	INP	
6	GND out	n.c.
7	+24 V DC out	n.c.

Connection X2

PIN	AC version	DC version
1	100 ... 240 V AC, ±10 %	0VDC (GND)
2	100 ... 240 V AC, ±10 %	10 ... 30 V DC

1) For further specifications please refer to the manual.

Pulse counters, electronic

LED pulse counters	Adding (AC+DC)	Codix 540
---------------------------	-----------------------	------------------

Dimensions

Dimensions in mm [inch]

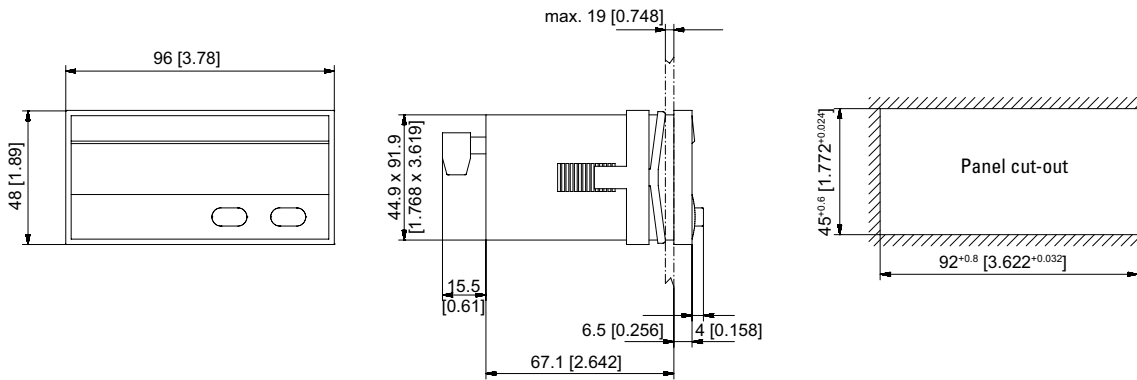

Product overview
Basics

Pulse counters

Preset counters

Hour meters
Timers

Frequency displays
Tachometers

Position displays

Multifunction
devices

Energy meters

Process devices

Temperature
devices

Strain-gauge
controllers

Accessories
Index

LED pulse counters

6 count modes (AC+DC)

Codix 541



The Codix 541 is a voltage powered pulse counter / position display with 4 count input modes: count direction, difference, addition, quadrature (phase discriminator) x1, x2 and x4, for fast and slow count pulses, with 6-digit LED display for NPN, PNP input signals.



DC 10 ... 30 V	AC 100 ... 240 V	Temperature range - 20° + 65°	High protection level IP65	Pulse counter/ Totalizer max. 60 kHz	Position display	Count with direction (DIR)	Differential count (up, dn)	Add/Add count (up, up)	Phase discriminator	Plug-in screw terminal
--------------------------	----------------------------	---	--------------------------------------	--	-------------------------	-----------------------------------	------------------------------------	-------------------------------	----------------------------	-------------------------------

Powerful

- Fast count input – input frequency max. 60 kHz.
- Robust housing – IP65 protected.
- Very bright LED display, 14 mm high.
- Position, difference, adding or count direction detection:
 - programmable for positive (PNP) or OV (NPN) switching input pulses.
 - fast count input with an input frequency of max. 60 kHz, can be damped to 30 Hz for mechanical contacts.
- Short start-up time – detects input pulses just 16 msec after being switched on => no pulses are lost with a simultaneous motor start-up.

User-friendly and universal

- Large keys – can also be operated when wearing gloves.
- Simple uniform menu-driven programming and operation – possible to enter the programming also during operation with a confirmation prompt.
- Individually programmable scaling: Multiplication and division factor (0.0001 ... 99.9999), to display corresponding engineering units, e.g. position in 1/10 mm or packaging units.
- 4 different count input modes: 2-channel count input for detecting count direction, difference or adding mode, quadrature with x1, x2 or x4 evaluation.
- Freely programmable setpoint.
- AC or DC power supply with sensor power supply.
- As an alternative to the HTL inputs, devices are available with a 4 ... 30 V DC input level, for use as parallel displays to PLCs.
- Optional output - as zero signal.

Order code 6.541 . 01 X . X X 0

- a** Output
1 = Optocoupler output
2 = No output¹⁾
- b** Power supply
0 = 100 ... 240 V AC, ±10 %¹⁾
3 = 10 ... 30 V DC¹⁾

- c** Input switching level
0 = Standard level (HTL)¹⁾
A = 4 ... 30 V DC

- Delivery specification**
- Digital display
 - Mounting clip
 - Gasket
 - 2 screw terminals
 - Instruction manual, multilingual

- Replacement parts**
- 7 pin screw terminal RM 3.81 1 ... 7: N100387
 - 2 pin screw terminal RM 5.08 1 ... 2: N100133

Accessories	Dimensions in mm [inch]	Order no.
Mounting frame with cut-out 92 x 45 [3.62 x 1.77]	for snap-on mounting on 35 [1.38] top-hat DIN rail, for counters 96 x 48 [3.74 x 1.89]	grey G300005

Suitable gaskets as well as further accessories can be found in the accessories section or in the accessories area of our website at: www.kuebler.com/accessories.

1) Stock types.

Pulse counters, electronic

LED pulse counters 6 count modes (AC+DC) Codix 541

Technical data

General technical data	
Display	6 digits; red 7 segment LED display; 14 mm [0.55"] high
Data backup	EEPROM
Operating temperature	-20°C ... +65°C [-4°F ... +149°F] (non-condensing)
Storage temperature	-25°C ... +70°C [-13°F ... +158°F]
Altitude	up to 2000 m [6562']

Electrical characteristics	
Power supply	10 ... 30 VDC, with reverse polarity protection 100 ... 240 V AC, ±10 %
Current consumption	max. 50 mA, 6 VA
EMC standards	EN 55011 class B EN 61000-6-2, EN 61000-6-3
Device safety	designed to protection class 2 application area pollution level 2
UL approval	file E128604

Mechanical characteristics	
Housing	front panel mount 96 x 48 mm [3.74 x 1.89"] acc. to DIN 43700; RAL 7021, dark grey
Protection	IP65 (front side)
Weight	approx. 150 g [5.29 oz]

Inputs	
Polarity of inputs	programmable, NPN or PNP for all inputs
Input resistance	approx. 5 kΩ
Counting frequency ¹⁾	max. 60 kHz, can be damped to 30 Hz at position display max. 25 kHz
Minimum pulse duration of the reset input	5 ms
Input switching level standard version (HTL)	
DC power supply	LOW 0 ... 0.2 x U _B (V DC)
	HIGH 0.6 x U _B ... 30 V DC
AC power supply	LOW 0 ... 4 V DC
	HIGH 12 ... 30 V DC
Input switching level at 4 ... 30 V DC	
	LOW 0 ... 2 V DC
	HIGH 4 ... 30 V DC

Outputs	
Power supply for sensors (AC version)	24 V DC ±15 %/100 mA
Output power optocouplers	max. 30 V DC, 10 mA

Applications for position displays and totalizers

- Positioning tasks on processing machines, such as sawing machines, milling machines, bending and folding machines, etc.
- Production data acquisition by means of piece counting (using difference or adding)
- Totalizing flow, quantity and other scalable media
- Counting tasks such as quantity and piece counting
- Accessories, OEM equipment or retrofitting to production machines
- Piece counting on die cutters, presses, extruders, wood-working machines, drilling machines, pick-and-place machines, guillotines, special-purpose vehicles etc.

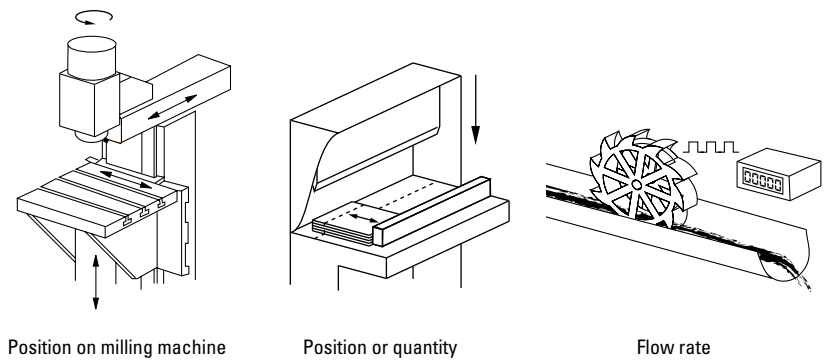

Block diagram

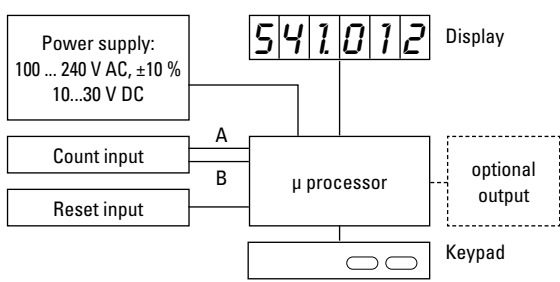

Terminal assignment

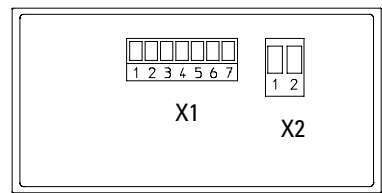

Connection X1

PIN	AC version	DC version
1	Optocoupler-output Emitter	
2	Optocoupler-output Collector	
3	Set	
4	INP B	
5	INP A	
6	GND out	n.c.
7	+24 V DC out	n.c.

Connection X2

PIN	AC version	DC version
1	100 ... 240 V AC, ±10 %	0V DC (GND)
2	100 ... 240 V AC, ±10 %	10 ... 30 V DC

1) Please refer to the manual.

Product overview
Basics
Pulse counters
Preset counters
Hour meters
Timers
Frequency displays
Tachometers
Position displays
Multifunction devices
Energy meters
Process devices
Temperature devices
Strain-gauge controllers
Accessories
Index

Pulse counters, electronic

LED pulse counters	6 count modes (AC+DC)	Codix 541
---------------------------	------------------------------	------------------

Dimensions

Dimensions in mm [inch]

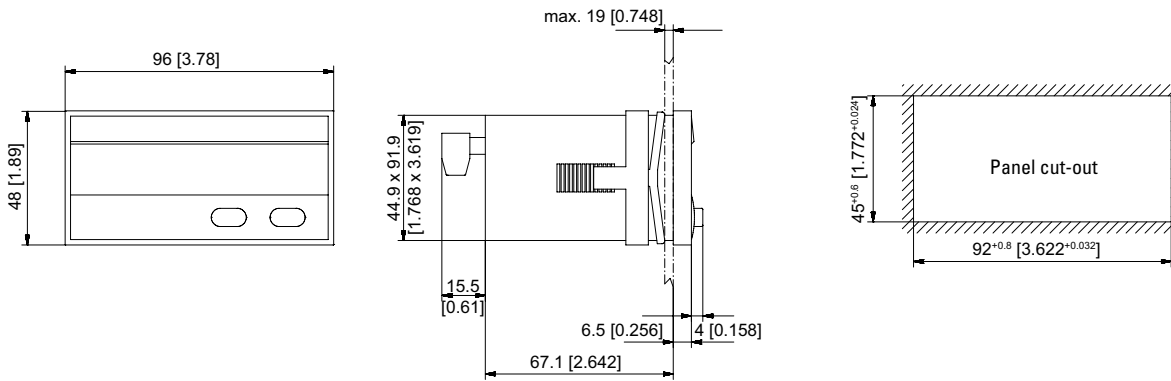

Product overview
Basics
Pulse counters
Preset counters
Hour meters
Timers
Frequency displays
Tachometers
Position displays
Multifunction devices
Energy meters
Process devices
Temperature devices
Strain-gauge controllers
Accessories
Index

Pulse counters, electronic

LCD modules Adding, 7 digits (DC) 190



The single-channel count module type 190 for PCB mounting, with 2 voltage ranges (4.75 ... 15 and 9 ... 60 V DC) and large 7-digit LCD display, boasts a very wide temperature range.

This ensures the device is extremely robust and suitable for many application areas, even under the harshest operating conditions.



 DC 4.75...60 V Power supply	 max. 10 kHz Max. count frequency	 PNP Input type	 High shock resistance	 -40°...+80°C Temperature range	 PCB mount	 7 LCDs LCD display	 Electrical reset
--	---	------------------------------	---------------------------	---------------------------------------	---------------	---------------------------	----------------------

Powerful

- Count frequency up to 10 kHz.
- 7-digit LCD display, 6 mm high.
- Low operating current.
- Wide operating voltage and temperature range.
- Very high shock and vibration resistance.

Simple

- Non-volatile memory (no battery).
- Single channel count input.
- Electrical reset.
- Very high reliability.
- Small size and very competitive price.

Order no.

Power supply
4.75 ... 15 V DC
9 ... 60 V DC

Order no.
6.190.012.F00 ¹⁾
6.190.012.G00

Art. no.
162 135
162 136

Delivery specification
· LCD counter module type 190
· Operating instructions

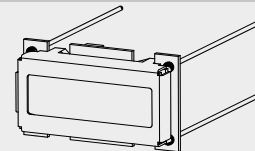

1) Stock types

Pulse counters, electronic

LCD modules	Adding, 7 digits (DC)	190
--------------------	------------------------------	------------

Technical data

General technical data	
Display	7 digits, LCD display, figure height 6 mm [0.24"]
Data backup	EEPROM
Memory	CMOS EEPROM non-volatile memory data backup up to 10 years
Operating temperature	-40°C ... +80°C [-40°F ... +176°F] (non-condensing)
Working temperature	-20°C ... +80°C [-4°F ... +176°F] (non-condensing)
Storage temperature	-50°C ... +90°C [-58°F ... +194°F]

Inputs	
Count input	HIGH 4 ... 60 V DC LOW 0 ... 0.7 V DC
max. counting frequency	10 kHz, edge triggered (negative edge)
Reset input	HIGH 4 ... 60 V DC LOW 0 ... 0.7 V DC
pulse length	1 ms edge triggered (positive edge)

Electrical characteristics	
Power supply	4.75 ... 15 V DC with reverse polarity protection 9 ... 60 V DC
Current consumption	8 mA at 4.75 ... 15 V DC 6 mA at 9 ... 60 V DC
EMC standards	EN 55011 class B EN 61000-6-2, EN 61000-6-3, EN 61326-1

The module must be protected against inductive voltage spikes and high energy noise interference.

Mechanical characteristics		
Housing	dimensions color	18.4 x 32.4 mm [0.72 x 1.28"] black
Weight		approx. 8 g [0.28 oz]
Shock resistance acc. to EN 60068-2-27		550 m/s ² , 11 ms
Vibration resistance acc. to EN 60068-2-6		50 ... 200 m/s ² , 10 ... 80 Hz

Dimensions

Dimensions in mm [inch]

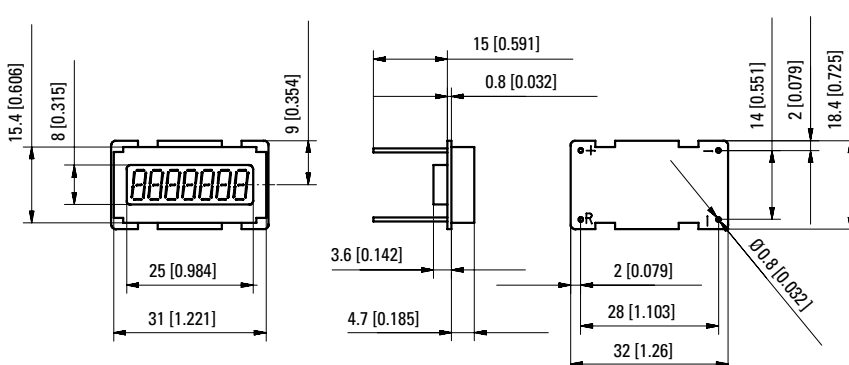

Terminal assignment

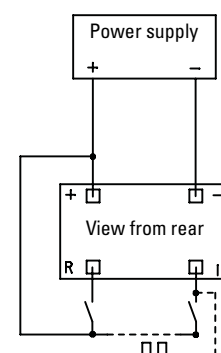

LCD modules **Adding, 6 digits (DC)** **192**



Type 192 is a single channel counter module for PCB mounting, with a large voltage range of 8 up to 28 V DC and a 6-digit LCD display.

Extremely robust as a result of its wide temperature range, the module is ideally suited for use in many application areas.



DC 8 ... 28 V Power supply	max. 100 Hz Max. count frequency	PNP Input type	High shock resistance	-40°...+80°C Temperature range	PCB mount	7 LCDs LCD display	Electrical reset
---	---	--------------------------	------------------------------	--	------------------	------------------------------	-------------------------

Powerful

- Count frequency up to 100 Hz.
- 6-digits LCD display, 5 mm high.
- Low operating current.
- Wide operating voltage and temperature range.
- High shock and vibration resistance.

Simple

- Non-volatile memory (no battery).
- Single channel count input.
- Electrical reset.
- Very high reliability.
- Small size and very competitive price.

Order no.

Power supply 8 ... 28 V DC	Order no. 6.192.012.H00 ¹⁾	Art. no. 162 135	Delivery specification · LCD counter module type 192 · Operating instructions
--------------------------------------	--	----------------------------	--

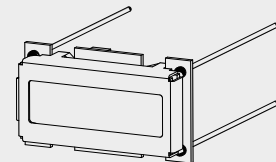

1) Stock types.

Pulse counters, electronic

LCD modules	Adding, 6 digits (DC)	192
--------------------	------------------------------	------------

Technical data

General technical data	
Display	6 digits, LCD display, figure height 5 mm [0.20"]
Data backup	EEPROM
Memory	CMOS EEPROM. non-volatile memory data backup up to 10 years (without battery)
Operating / working / storage temperature	-40°C ... +85°C [-40°F ... +185°F] (non-condensing)
Humidity	95 % rel +32°C [+90°F] for 2 hours

Inputs	
Count input max. counting frequency	8 ... 28 V DC 100 Hz
Reset input pulse length	8 ... 28 V DC min. 500 msec

Electrical characteristics	
Power supply	8 ... 28 V DC
Current consumption	max. 3 mA at 4.5 V DC 10 mA at 28 V DC
EMC standards	EN 55011 class B EN 61000-6-2, EN 61000-6-3, EN 61326-1, EN 61326-3-1
The module must be protected against inductive voltage spikes and high energy noise interference.	

Mechanical characteristics	
Housing	dimensions 18.4 x 32.4 mm [0.72 x 1.28"] color black
Weight	approx. 8 g [0.28 oz]
Vibration resistance acc. to EN 60068-2-6	10 ... 80 m/s ² , 10 ... 75 Hz

Dimensions

Dimensions in mm [inch]

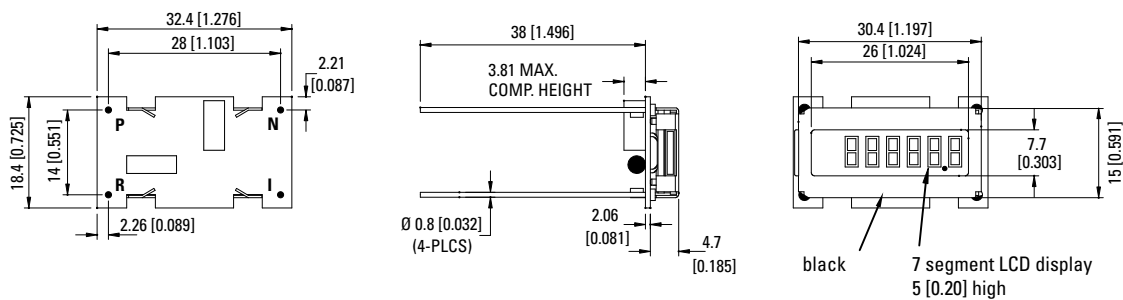

Terminal assignment

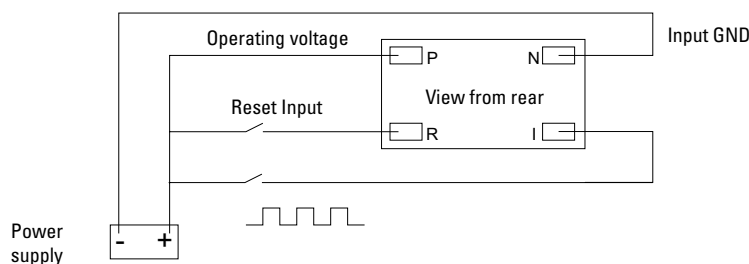

Product overview Basics
 Pulse counters
 Preset counters
 Hour meters Timers
 Frequency displays Tachometers
 Position displays
 Multifunction devices
 Energy meters
 Process devices
 Temperature devices
 Strain-gauge controllers
 Accessories Index

Micro counters

High shock resistance (DC)

K 46 / K 47

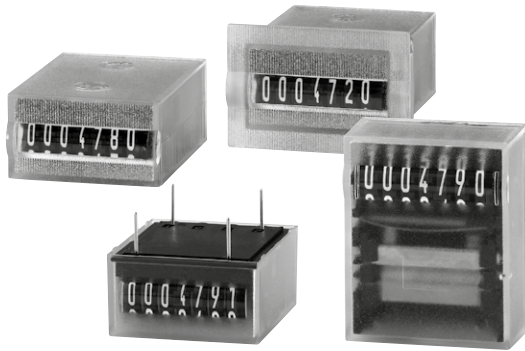

The micro adding counters K 46 and K 47 boast a very high level of shock resistance. As panel mount and PCB mount counters they can be used in a wide variety of applications.

The counters are non-resettable and are highly tamper-proof thanks to their sealed (potted) housings.

Characteristics

- 6-digit (K 46) or 7-digit (K 47) micro adding counters.
- Economical.
- Low power consumption; suitable for battery operation.
- Small dimensions, large optical figures.
- Different viewing possibilities.
- Panel mount with spring clips or PCB mount versions.

Benefits

- Machine solderable and washable.
- High shock resistance.
- Long service life.
- IP65 protection.
- Stores values if power fails.

Applications

General quantity counting, alarm systems, coin-operated machines, electricity meters, vending and slot machines, photocopiers, medical equipment, car washes

Type series

Fig.	Mounting options	Display	el. connection	IP protection	6 digits	7 digits
1)	Panel mount with latch	front side	flying leads	front side	K 46.20	K 47.20
2)	PCB mount, upright	front side	solder pins	front side/on rear	K 46.80	K 47.80
3)	PCB mount, lying	on the top	solder pins	front side/on rear	–	K 47.90
4)	PCB mount, hanging	front side	solder pins	front side/on rear	–	K 47.91
5)	PCB mount, lying	front side	solder pins	front side/on rear	K 46.95	–

Order information

- Art. no. 1.7X0.XX0.0XX
- For options please give exact counter type, voltage and options e.g.:
K 46.20 – 12 V DC/0 – temperature range -20°C ... +70°C [-4°F ... +158°F]

Mounting options and position of the display

- 1) Panel mount
display front side

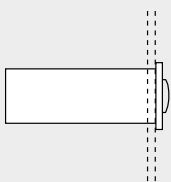

- 2) PCB mount, upright
display front side

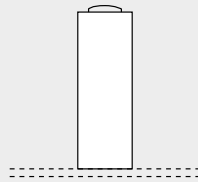

- 3) PCB mount, lying
display on the top

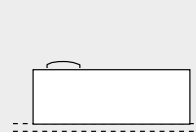

- 4) PCB mount, hanging
display front side



- 5) PCB mount, lying
display front side



- Optional: PCB mount, lying
display at the bottom



Pulse counters, electromechanical

Micro counters	High shock resistance (DC)	K 46 / K 47
-----------------------	-----------------------------------	--------------------

Technical data		
Electrical connection	panel mount	flying leads, AWG 22 approx. 150 mm [5.91"], 6 mm [0.24"] stripped wire ends, tinned
	PCB mount	solder pins \varnothing 0.64 mm [0.025"]
Power consumption	up to 12 V DC at 24 V DC	approx. 70 mW approx. 150 mW
Rated voltage		1.5 / 3 / 4.5 / 5 / 6 / 12 / 24 V DC, -10 % / +20 %
Counting frequency		max. 10 Hz (type 0)
Pulse duration / pulse interval		min. 50 ms / min. 50 ms
Cycle duration factor		100 %
Number of digits		6 (K 46), 7 (K 47)
Counting system		adding
Height of figures (optical)	K 46	4 x 1.7 mm [0.16 x 0.067"]
	K 47	4 x 1.25 mm [0.16 x 0.049"]
Color of figures		white on black
Reset		no reset
Operating temperature		-10°C ... +60°C [+14°F ... +140°F] (non-condensing)
Mounting position		horizontal, other on request

Operating life	> 50 x 10 ⁶ pulses
Soldering temperature	max. 265°C [+509°F], 3 s
Protection	IP65 (K 46.20, K 47.20: only front side)
Housing	PC (Polycarbonate)
Weight	12 ... 14 g [0.42 ... 0.49 oz]
EMC standards	EN 55011 class B EN 61000-6-2, EN 61000-6-3

Options	
K 46.20, K 46.80, K 47.20, K 47.80	flat pin 0.8 x 2.8 mm [0.032 x 0.11"] and push on connectors
K 46.20, K 47.20	solder pins \varnothing 0.64 mm [0.025"]
Further options	<ul style="list-style-type: none"> - different voltages - counting frequency > 10 Hz - different color of figures - extended temperature range: -30°C ... +85°C [-22°F ... +185°F] or -20°C ... +70°C [-4°F ... +158°F]

Panel mount display front side Type K 46.20 / K 47.20

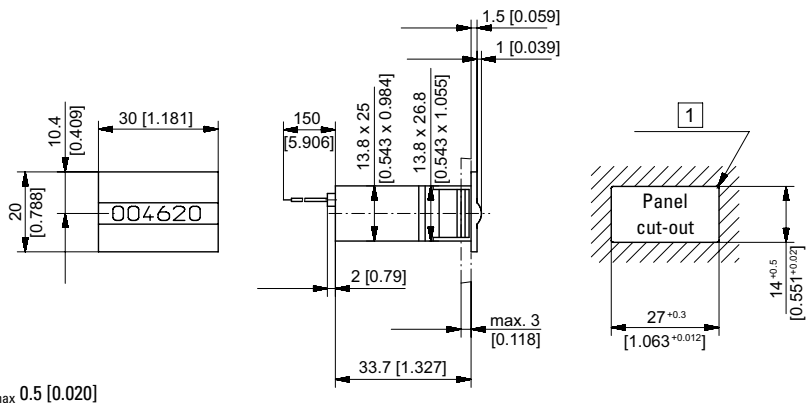
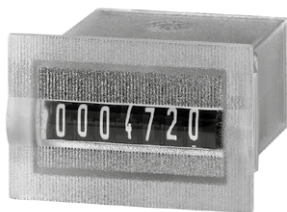

Type	Voltage	Display	Art. no.						24 V
			3 V	4.5 V	5 V	6 V	12 V		
K 46.20	DC (10 Hz) / 0	6 digits	on request	on request	on request	on request	1.700.200.012 ¹⁾	1.700.200.013 ¹⁾	
K 47.20	DC (10 Hz) / 0	7 digits	1.710.200.006	1.710.200.008	1.710.200.009	1.710.200.010	1.710.200.012 ¹⁾	1.710.200.013 ¹⁾	

PCB mount, upright display front side Type K 46.80 / K 47.80

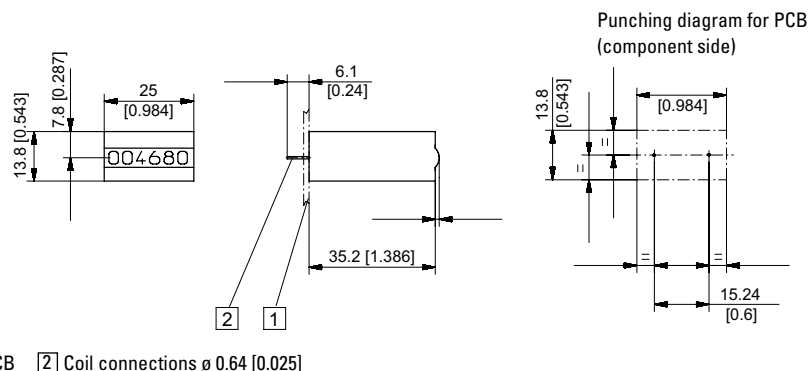
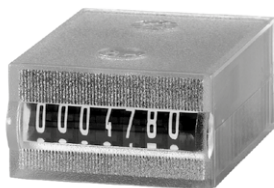

Type	Voltage	Display	Art. no.					
			3 V	4.5 V	5 V	6 V	12 V	24 V
K 46.80	DC (10 Hz) / 0	6 digits	on request	on request	on request	on request	1.700.800.012	1.700.800.013 ¹⁾
K 47.80	DC (10 Hz) / 0	7 digits	1.710.800.006	1.710.800.008	1.710.800.009	1.710.800.010	1.710.800.012	1.710.800.013

Dimensions in mm [inch]

1) Stock types.

Pulse counters, electromechanical

Micro counters

High shock resistance (DC)

K 46 / K 47

PCB mount, lying
display front side
Type K 47.90

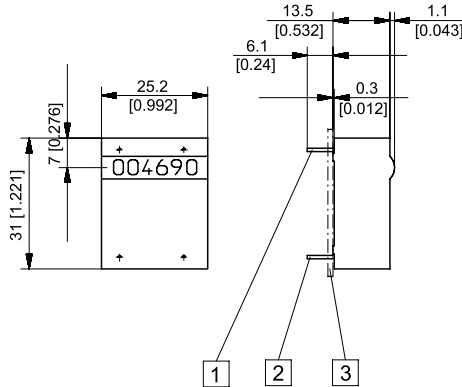

Punching diagram for PCB
(component side)

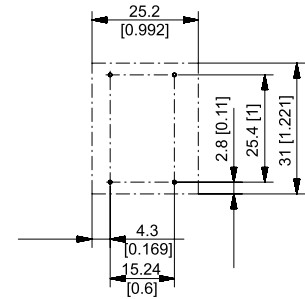

1 Mounting pin without el. function \varnothing 0.64 [0.025] 2 Coil connections \varnothing 0.64 [0.025] 3 PCB

Type	Voltage	Display	Art. no.						
			3 V	4.5 V	5 V	6 V	12 V	24 V	
K 47.90	DC (10 Hz) / 0	7 digits	1.710.900.006	1.710.900.008	1.710.900.009	1.710.900.010	1.710.900.012	1.710.900.013	

PCB mount, hanging
display front side
Type K 47.91

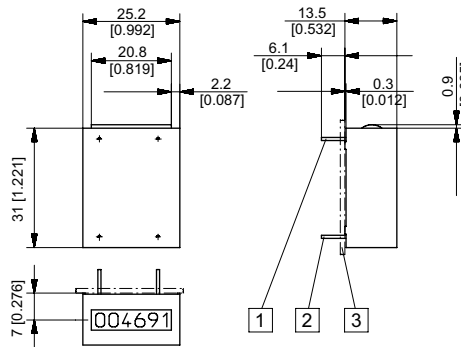

Punching diagram for PCB
(component side)

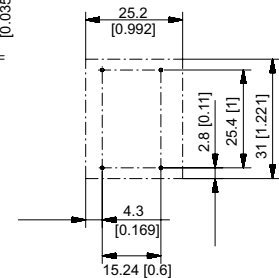

1 Mounting pin without el. function \varnothing 0.64 [0.025] 2 Coil connections \varnothing 0.64 [0.025] 3 PCB

Type	Voltage	Display	Art. no.						
			3 V	4.5 V	5 V	6 V	12 V	24 V	
K 47.91	DC (10 Hz) / 0	7 digits	1.710.910.006	1.710.910.008	1.710.910.009	1.710.910.010	1.710.910.012	1.710.910.013	

PCB mount, lying
display front side
Type K 46.95

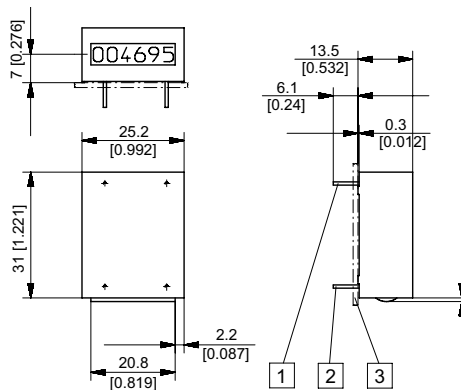
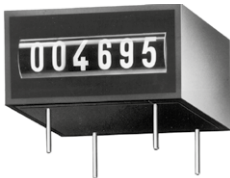

Punching diagram for PCB
(component side)

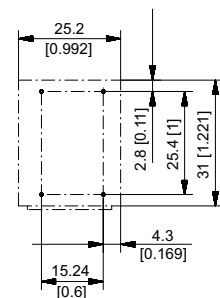

1 Mounting pin without el. function \varnothing 0.64 [0.025] 2 Coil connections \varnothing 0.64 [0.025] 3 PCB

Type	Voltage	Display	Art. no.						
			3 V	4.5 V	5 V	6 V	12 V	24 V	
K 46.95	DC (10 Hz) / 0	6 digits	on request	on request	1.700.950.009	on request	1.700.950.012	1.700.950.013	

Dimensions in mm [inch]

Pulse counters, electromechanical

Micro counters	Magnetic field resistant and high shock resistance (DC)	K 66 / K 67
-----------------------	--	--------------------



The micro adding counters K 66 (6-digit) and K 67 (7-digit) boast a very high level of shock resistance and, as a result of the patented ACR counting system, are not affected by magnetic fields.

They can be used as either panel mount or as PCB mount devices in a wide variety of application areas, where a high level of resistance against tampering is required.

Product overview Basics
Pulse counters
Preset counters
Hour meters Timers
Frequency displays Tachometers
Position displays
Multifunction devices
Energy meters
Process devices
Temperature devices
Strain-gauge controllers
Accessories Index

Characteristics

- Not affected by magnetic fields, as moving parts are made of plastic or non-ferrous metal (patented system)
- Maximum shock resistance, as a counter-rotating movement is required for counting, ACR system (Air Coil Reverse, patented)
- Low power consumption; suitable for battery operation
- Very compact size, large figures
- Different viewing possibilities

Benefits

- Machine solderable and washable
- IP65 protection
- Long service life
- Stores values if power fails

Applications

General quantity counting, photocopiers, electricity meters, vending and slot machines, coin-operated machines, car washes, alarm systems, medical equipment, heat quantity measurement

Type series

Fig.	Mounting options	Display	el. connection	IP protection	6 digits	7 digits
1)	Panel mount with latch	front side	flying leads	front side	–	K 67.20
2)	PCB mount, upright	front side	solder pins	front side/on rear	–	K 67.80
3)	PCB mount, lying	on the top	solder pins	front side/on rear	–	K 67.90
4)	PCB mount, hanging	front side	solder pins	front side/on rear	K 66.91	K 67.91
5)	PCB mount, lying	front side	solder pins	front side/on rear	K 66.95	K 67.95

Order information

- Art. no. 1.680.9X0.0XX
- For options please give exact counter type, voltage and options e.g.:
K 67.20 – 9 V DC/0 – temperature range -20°C ... +70°C [-4°F ... +158°F]

Mounting options and position of the display

1) Panel mount
display front side

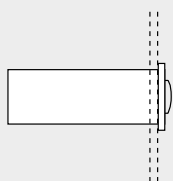

2) PCB mount, upright
display front side

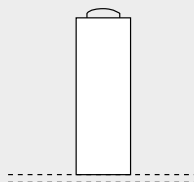

3) PCB mount, lying
display on the top



4) PCB mount, hanging
display front side



5) PCB mount, lying
display front side

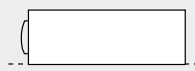

Optional: PCB mount, lying
display at the bottom



Pulse counters, electromechanical

Micro counters	Magnetic field resistant and high shock resistance (DC)	K 66 / K 67
-----------------------	--	--------------------

Technical data		
Electrical connection	panel mount	flying leads, AWG 22 approx. 150 mm [5.91"], 6 mm [0.24"] stripped wire ends, tinned
	PCB mount	solder pins \varnothing 0.64 mm [0.025"]
Power consumption: at 20°C [68°F]	up to 6 V DC	approx. 70 mW
	up to 12 V DC at 24 V DC	approx. 120 mW approx. 500 mW
Rated voltage	1.5 / 3 / 4.5 / 5 / 6 / 12 / 24 V DC, -10 % / +20 %	
Counting frequency	max. 10 Hz (type 0)	
Pulse duration / pulse interval	min. 50 ms / min. 50 ms	
Cycle duration factor	100 %	
Counting system	adding	
Height of figures (optical)	K 66	4 x 1.7 mm [0.16 x 0.067"]
	K 67	4 x 1.25 mm [0.16 x 0.049"]
Color of figures	white on black	
Reset	no reset	
Operating temperature	-10°C ... +60°C [+14°F ... +140°F] (non-condensing)	
Mounting position	horizontal, other on request	
Operating life	> 50 x 10 ⁶ pulses	
Soldering temperature	max. 265°C [+509°F], 3 s	

Protection	IP65 (K 66.20, K 67.20: only front side)
Housing	PC (Polycarbonate), transparent types with protection IP65 are sealed
Weight	9 ... 11 g [0.32 ... 0.39 oz]
EMC standards	EN 55011 class B EN 61000-6-2, EN 61000-6-3

Options	
K 66.20, K 66.80, K 67.20, K 67.80	flat pin 0.8 x 2.8 mm [0.032 x 0.11"] and push on connectors X.XX7.XXX.XXX
K 66.20, K 67.20	solder pins \varnothing 0.64 mm [0.025"] X.XX1.XXX.XXX
K 66.80, K 67.80	flying leads, AWG 22 approx. 150 mm [5.91"]
Further options	<ul style="list-style-type: none"> - different voltages - counting frequency > 10 Hz - different color of figures - extended temperature range -30°C ... +85°C [-22°F ... +185°F] or -20°C ... +70°C [-4°F ... +158°F] - solderable and washable version

Panel mount with latch display front side
Type K 67.20

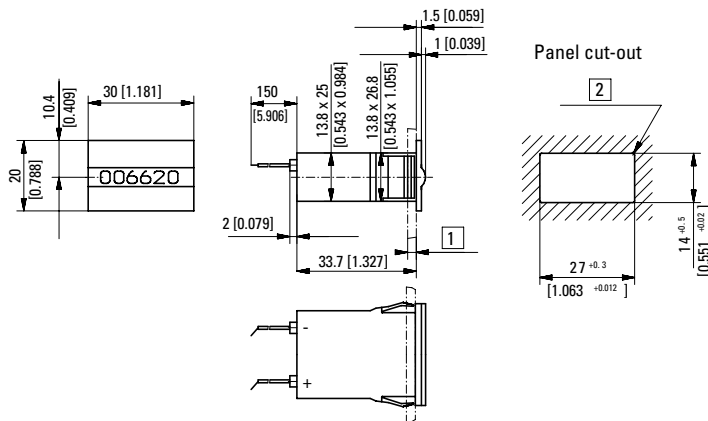
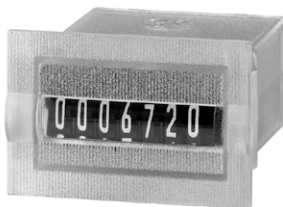

1) 1.2 ... 3 mm [0.047 x 0.12] 2) R_{max} 0.5 [0.020]

Type	Voltage	Display	Art. no.					
			3 V	4.5 V	5 V	6 V	12 V	24 V
K 67.20	DC (10 Hz) / 0	7 digits	1.660.200.006	1.660.200.008	1.660.200.009 ¹⁾	1.660.200.010	1.660.200.012 ¹⁾	1.660.200.013 ¹⁾

PCB mount upright display front side
Type K 67.80

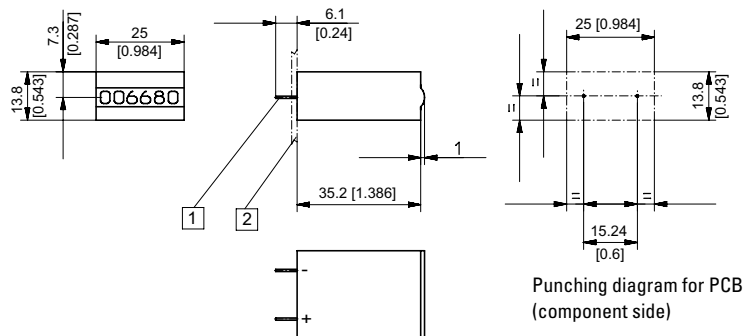

1) Coil connections \varnothing 0.64 [0.025] 2) PCB

Type	Voltage	Display	Art. no.					
			3 V	4.5 V	5 V	6 V	12 V	24 V
K 67.80	DC (10 Hz) / 0	7 digits	1.660.800.006	1.660.800.008	1.660.800.009	1.660.800.010	1.660.800.012	1.660.800.013

Dimensions in mm [inch]

1) Stock types.

Product overview Basics
Pulse counters
Preset counters
Hour meters Timers
Frequency displays Tachometers
Position displays
Multifunction devices
Energy meters
Process devices
Temperature devices
Strain-gauge controllers
Accessories Index

Pulse counters, electromechanical

Micro counters **Magnetic field resistant and high shock resistance (DC)** **K 66 / K 67**

PCB mount, lying display on the top
Type K 67.90

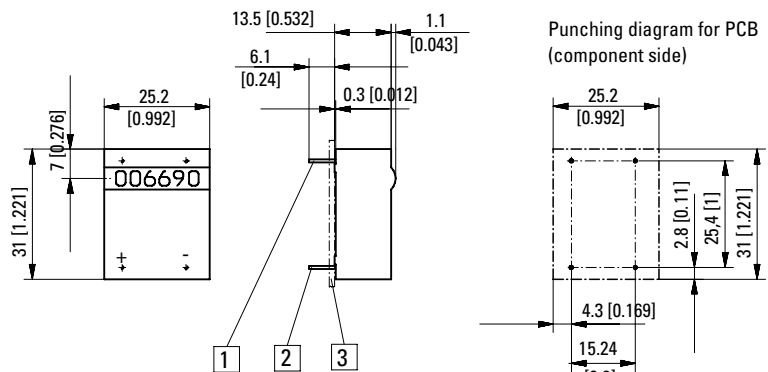

1 Mounting pin without el. function \varnothing 0.64 [0.025] 2 Coil connections \varnothing 0.64 [0.025] 3 PCB

Type	Voltage	Display	Art. no.							
			3 V	4.5 V	5 V	6 V	12 V	24 V		
K 67.90	DC (10 Hz) / 0	7 digits	1.660.900.006	1.660.900.008	1.660.900.009	1.660.900.010	1.660.900.012	1.660.900.013		

PCB mount, hanging display front side
Type K 66.91 / K 67.91

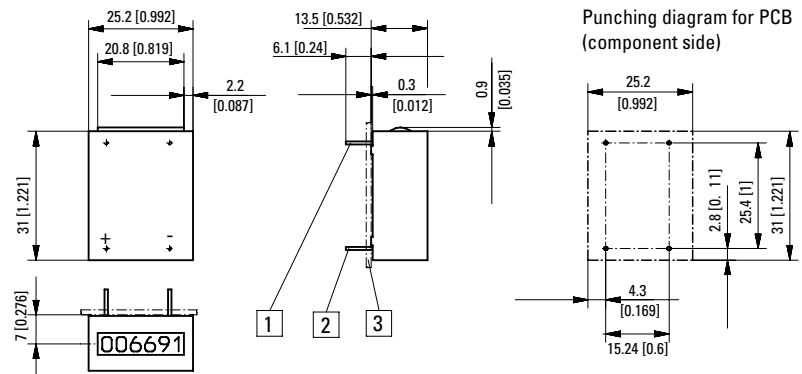
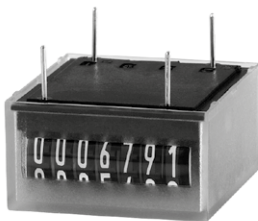

1 Mounting pin without el. function \varnothing 0.64 [0.025] 2 Coil connections \varnothing 0.64 [0.025] 3 PCB

Type	Voltage	Display	Art. no.							
			3 V	4.5 V	5 V	6 V	12 V	24 V		
K 66.91	DC (10 Hz) / 0	6 digits	on request	on request	1.650.910.009	on request	1.650.910.012	1.650.910.013		
K 67.91	DC (10 Hz) / 0	7 digits	1.660.910.006	1.660.910.008	1.660.910.009	1.660.910.010	1.660.910.012	1.660.910.013		

PCB mount lying display front side
Type K 66.95 / K 67.95

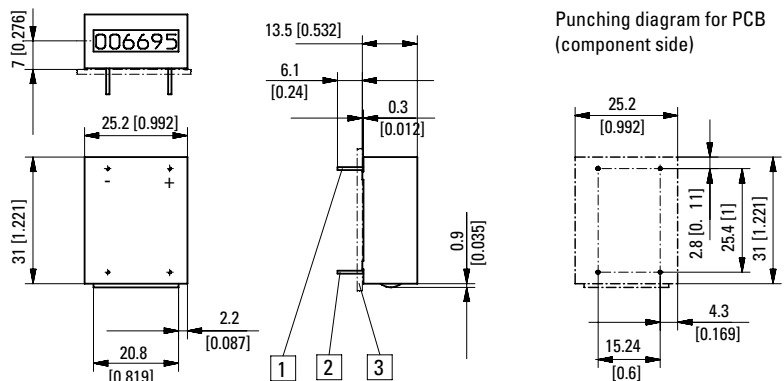
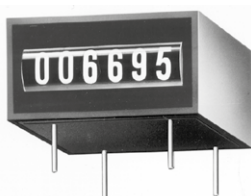

1 Mounting pin without el. function \varnothing 0.64 [0.025] 2 Coil connections \varnothing 0.64 [0.025] 3 PCB

Type	Voltage	Display	Art. no.							
			3 V	4.5 V	5 V	6 V	12 V	24 V		
K 66.95	DC (10 Hz) / 0	6 digits	on request	on request	1.650.950.009	on request	1.650.950.012	1.650.950.013		
K 67.95	DC (10 Hz) / 0	7 digits	1.660.950.006	1.660.950.008	1.660.950.009	1.660.950.010	1.660.950.012	1.660.950.013		

Dimensions in mm [inch]

Product overview
Basics
Pulse counters
Preset counters
Hour meters
Timers
Frequency displays
Tachometers
Position displays
Multifunction devices
Energy meters
Process devices
Temperature devices
Strain-gauge controllers
Accessories
Index

Micro counters

High shock resistance (AC+DC)

K 04 ... K 07 / AK 07

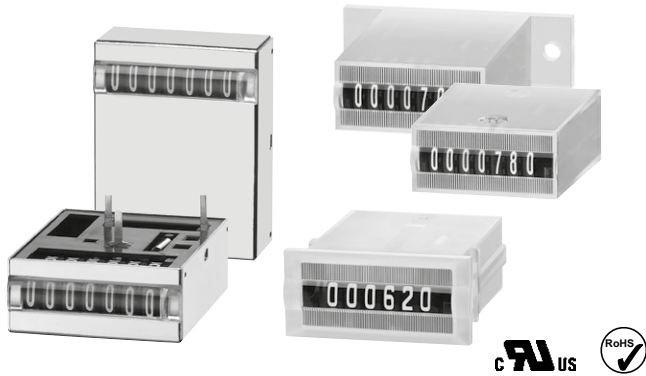

The micro adding counter families K 04 to K 07 and AK 07 are available in a very wide variety of models and can be used in both DC as well as in AC applications.

As panel mount, base mount and PCB mount counters with a very high level of shock resistance they can be used for numerous diverse application areas.



Characteristics

- Low power consumption; suitable for battery operation.
- Very compact size, large optical figures.
- Different viewing possibilities.
- Panel mount counter with moulded spring clips, base mount counter with screw fixing or PCB mount versions.
- Version with additional magnetic shielding thanks to sheet-steel enclosure (K 0X.40 and K 0X.50).

Benefits

- Machine solderable and washable.
- Stores values if power fails.
- High shock resistance, long service life, IP65 protection.

Applications

General quantity counting, alarm systems, coin-operated machines, electricity meters, vending and slot machines, photocopiers, medical equipment, car washes.

Type series

Fig.	Mounting options	Display	Housing	IP protection	4 digits	5 digits	6 digits	7 digits
1)	Panel mount with latch	front side	plastic	front side	K 04.20	K 05.20	K 06.20	K 07.20
2)	PCB mount, lying	on the top	sheet steel	–	K 04.40	–	–	K 07.40
3)	PCB mount, hanging	front side	sheet steel	–	–	–	–	K 07.50
4)	PCB mount, upright	front side	plastic	front side	–	–	K 06.80	K 07.80
5)	PCB mount, lying	on the top	plastic	front side/on rear	–	–	–	K 07.90
6)	Base mount, upright	front side	plastic	front side	–	–	–	AK 07.00

Order information

- Art. no.
- For options please give exact counter type, voltage and options e.g.: K 06.20 – 9 V DC/0 – temperature range -20°C ... +70°C [-4°F ... +158°F]

Mounting options and position of the display

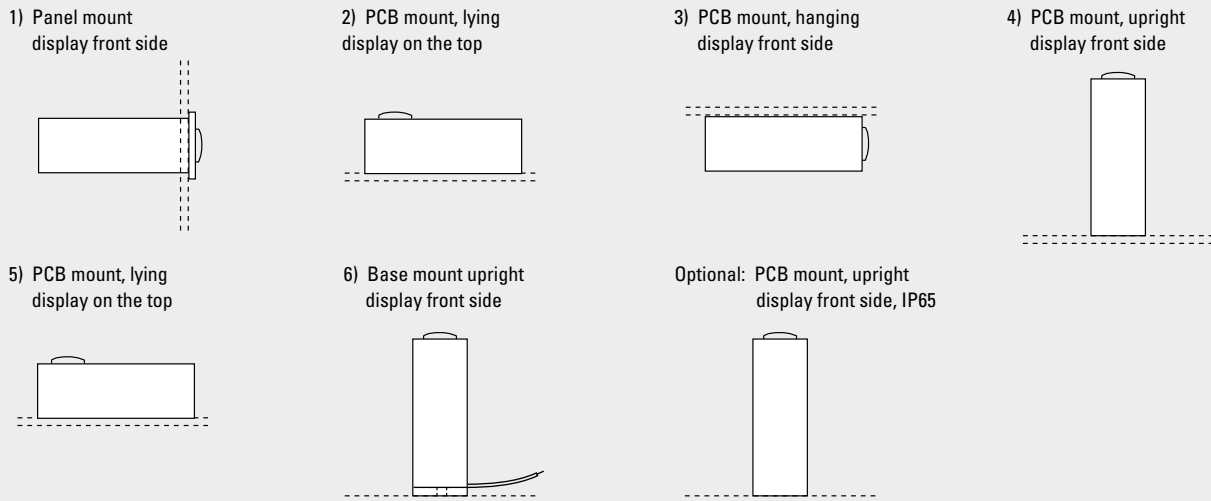

Pulse counters, electromechanical

Micro counters	High shock resistance (AC+DC)	K 04 ... K 07 / AK 07
-----------------------	--------------------------------------	------------------------------

Accessories	Dimensions in mm [inch]	Order no.
Gasket 32 x 15 [1.26 x 0.59]	for cut-out 27 x 13 [1.06 x 0.51], suitable for K 06.20 and K 07.20	N511058

Technical data	
Electrical connection	panel mount, base mount flying leads, AWG 22 approx. 150 mm [5.91"], 6 mm [0.24"] stripped wire ends, tinned solder pins \varnothing 0.4 x 1.2 mm [0.016 x 0.047"] PCB mount
Power consumption (at 20°C [68°F] and normal voltage)	at 10 Hz (type 0) approx. 50 mW at 25 Hz (type 1) approx. 250 mW at 10 Hz (type a0) approx. 800 mVA
Rated voltage	type 0 1.5/3/4.5/5/6/12/24 V DC, -10 %, +20 % type 1 3/4.5/5/6/12/24 V DC, \pm 10 % type a0 12/24/115/230 V AC, \pm 10 %
Counting frequency	max. 10 and 25 Hz
Pulse duration	at 10 Hz (type 0 and a0) min. 50 ms at 25 Hz (type 1) min. 20 ms
Pulse interval	at 10 Hz (type 0 a0) min. 50 ms at 25 Hz (type 1) min. 20 ms
Cycle duration factor	100 %
Number of digits	4, 5, 6 and 7
Counting system	adding
Height of figures	K 04, K 06, AK 06 4 x 1.7 mm [0.16 x 0.067"] optical K 05, K 07, AK 07 4 x 1.2 mm [0.16 x 0.047"] optical
Color of figures	white on black
Reset	no reset
Operating temperature	-10°C ... +60°C [+14°F ... +140°F] (non-condensing)
Mounting position	horizontal, other on request

Soldering temperature	265°C [+509°F], 3 s
Operating life	> 50 x 10 ⁶ pulses
Solderable and wash proof types	K 0X.92, K 06.90, K 07.90
Protection	K 0X.92, K 0X.90 IP65 AK 0X.00, K 0X.80, K 0X.20 IP65 (only front side) other types depending on kind of mounting
UL approval	file E128604
Housing	PC (Polycarbonate), transparent or sheet steel types (see table) with IP65 protection, fully sealed (potted)
Weight	15 ... 18 g [0.53 ... 0.63 oz]
EMC standards	EN 55011 class B EN 61000-6-2, EN 61000-6-3
Device safety	designed to protection class EN 61010 part 1 application area 2 pollution level 2
UL approval	file E128604

Options	
K 0x.20	flat pin 0.5 x 2.8 mm [0.020 x 0.11"] Art. no.: 1.1X7.XX0.XXX flat pin 0.4 x 1.2 mm [0.016 x 0.047"] Art. no.: 1.1X9.XX0.XXX • different voltages • version not potted • different figure colors • different lengths of flying leads • different connections • different temperature range, depends on version -30°C ... +85°C [-22°F ... +185°F] or -20°C ... +70°C [-4°F ... +158°F]

Product overview
Basics
Pulse counters
Preset counters
Hour meters
Timers
Frequency displays
Tachometers
Position displays
Multifunction devices
Energy meters
Process devices
Temperature devices
Strain-gauge controllers
Accessories
Index

Pulse counters, electromechanical

Micro counters

High shock resistance (AC+DC)

K 04 ... K 07 / AK 07

**Panel mount counter
4- and 5-digit display front side
Type K 04.20 / K 05.20**

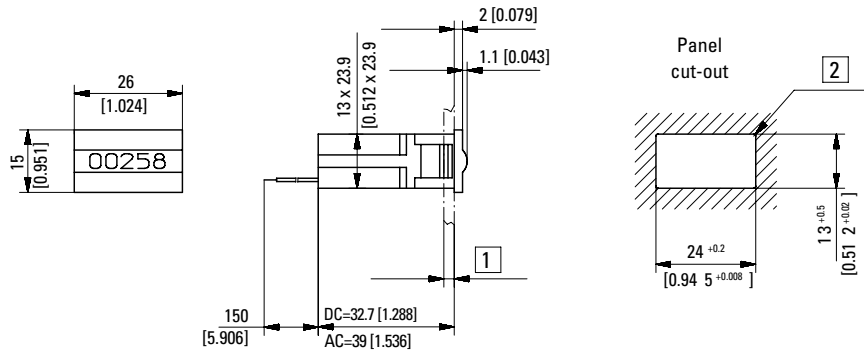

1) 1.2 ... 3 [0.047 x 0.12] 2) R_{max} 0.5 [0.020]

Type	Voltage	Display	Art. no.							
			3 V	4.5 V	12 V	24 V	115 V	230 V		
K 04.20	DC (10 Hz) / 0	4 digits	1.100.200.006	1.100.200.008	on request	on request	1.100.200.054	1.100.200.056		
	DC (25 Hz) / 1				1.100.200.032	1.100.200.033				
	AC (10 Hz) / a0				1.100.200.051					
K 05.20	DC (10 Hz) / 0	5 digits	1.110.200.006	1.110.200.008	on request	1.110.200.013 ¹⁾	1.110.200.054	1.110.200.056 ¹⁾		
	DC (25 Hz) / 1				1.110.200.032	1.110.200.033				
	AC (10 Hz) / a0				1.110.200.051					

**Panel mount counter
6- and 7-digit display front side
Type K 06.20 / K 07.20**

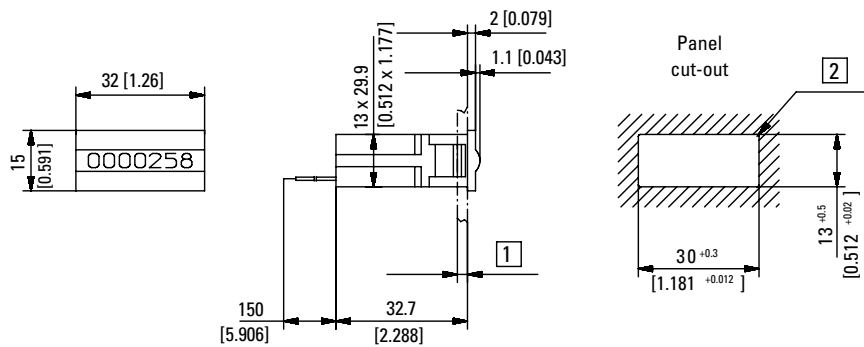

1) 1.2 ... 3 [0.047 x 0.12] 2) R_{max} 0.5 [0.020]

Type	Voltage	Display	Art. no.							
			3 V	4.5 V	12 V	24 V	115 V	230 V		
K 06.20	DC (10 Hz) / 0	6 digits	1.120.200.006	1.120.200.008	on request	1.120.200.013	1.120.200.054	1.120.200.056		
	DC (25 Hz) / 1				1.120.200.032	1.120.200.033				
	AC (10 Hz) / a0				1.120.200.051					
K 07.20	DC (10 Hz) / 0	7 digits	1.130.200.006	1.130.200.008	1.130.200.012 ¹⁾	1.130.200.013	1.130.200.054 ¹⁾	1.130.200.056		
	DC (25 Hz) / 1				1.130.200.032 ¹⁾	1.130.200.033 ¹⁾				
	AC (10 Hz) / a0				1.130.200.051					

Pulse counters, electromechanical

Micro counters **High shock resistance (AC+DC)** **K 04 ... K 07 / AK 07**

PCB mount, lying
4- digit display on the top
Type K 04.40

Color of housing blue (zinc-plated)

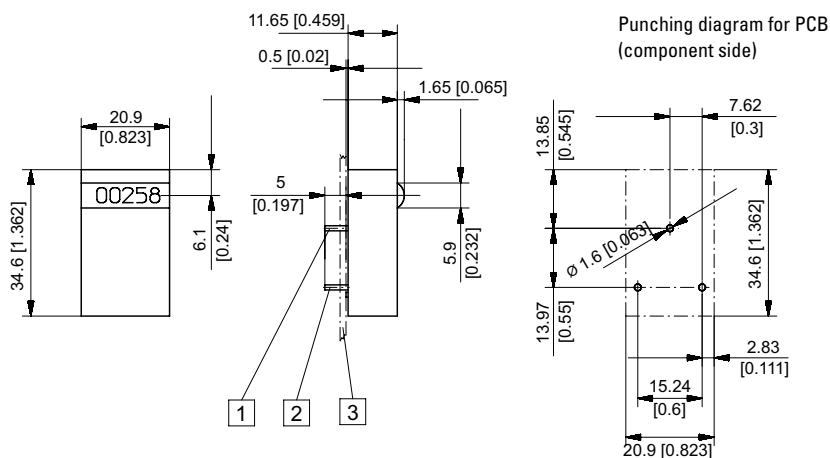

- 1] Mounting pin without el. function 0.4 x 1.2 [0.016 x 0.047]
 2] Coil connections 0.4 x 1.2 [0.016 x 0.047] 3] PCB

Type	Voltage	Display	Art. no.			
			3 V	4.5 V	12 V	24 V
K 04.40	DC (10 Hz) / 0	4 digits	1.100.401.006	1.100.401.008	on request	on request
	DC (25 Hz) / 1				1.100.401.032	1.100.401.033

PCB mount, lying
7-digit display on the top
Type K 07.40

Color of housing blue (zinc-plated)

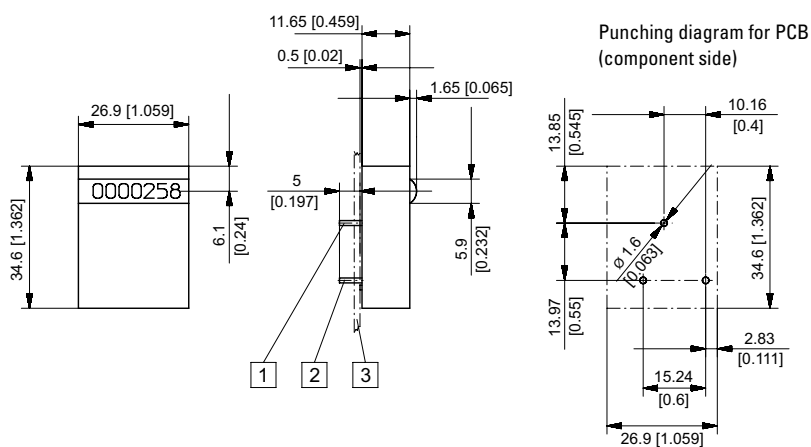
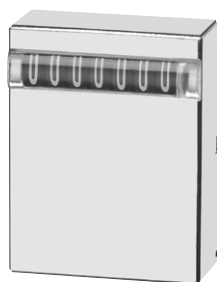

- 1] Mounting pin without el. function 0.4 x 1.2 [0.016 x 0.047]
 2] Coil connections 0.4 x 1.2 [0.016 x 0.047] 3] PCB

Type	Voltage	Display	Art. no.			
			3 V	4.5 V	12 V	24 V
K 07.40	DC (10 Hz) / 0	7 digits	1.130.401.006	1.130.401.008 ¹⁾	on request	on request
	DC (25 Hz) / 1				1.130.401.032	1.130.401.033

Pulse counters, electromechanical

Micro counters

High shock resistance (AC+DC)

K 04 ... K 07 / AK 07

PCB mount, hanging
7-digit display front side
Type K 07.50

Color of housing blue (zinc-plated)

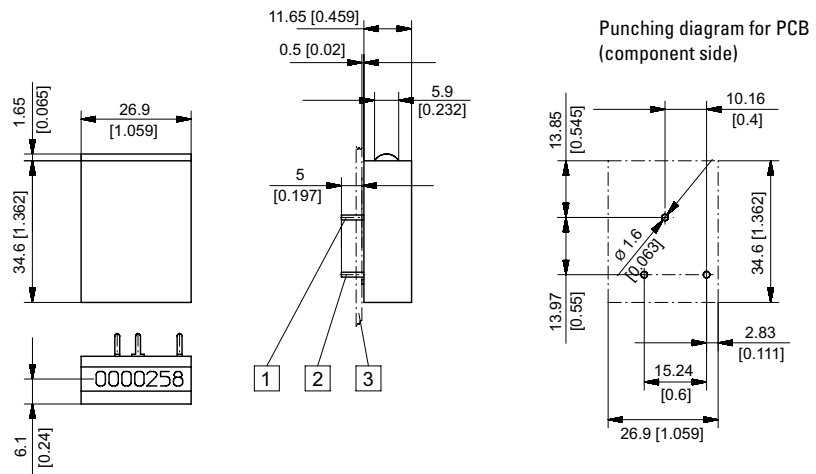
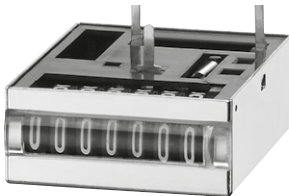

- 1) Mounting pin without el. function 0.4 x 1.2 [0.016 x 0.047]
 2) Coil connections 0.4 x 1.2 [0.016 x 0.047] 3) PCB

Type	Voltage	Display	Art. no.			
			3 V	4.5 V	12 V	24 V
K 07.50	DC (10 Hz) / 0	7 digits	1.130.501.006	1.130.501.008	on request	on request
	DC (25 Hz) / 1				1.130.501.032	1.130.501.033

PCB mount, upright
6- and 7-digit display front side
Type K 06.80 / K 07.80

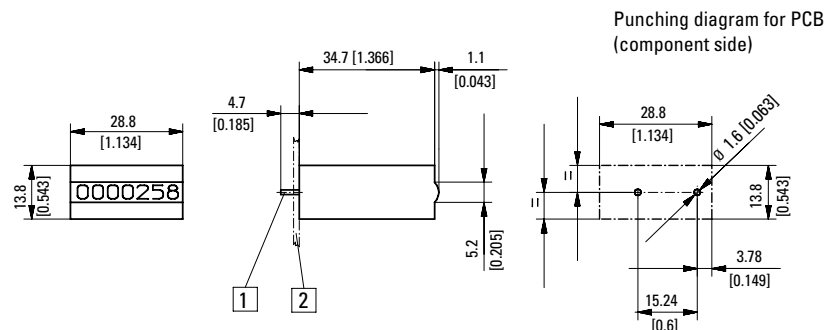

- 1) Coil connections 0.4 x 1.2 [0.016 x 0.047] 2) PCB

Type	Voltage	Display	Art. no.							
			3 V	4.5 V	12 V	24 V	115 V	230 V		
K 06.80	DC (10 Hz) / 0	6 digits	1.120.800.006	1.120.800.008	on request	on request				
	DC (25 Hz) / 1				1.120.800.032	1.120.800.033				
	AC (10 Hz) / a0				1.120.800.051	1.120.800.054	1.120.800.056			
K 07.80	DC (10 Hz) / 0	7 digits	1.130.800.006	1.130.800.008	on request	on request				
	DC (25 Hz) / 1				1.130.800.032 1)	1.130.800.033				
	AC (10 Hz) / a0				1.130.800.051	1.130.800.054	1.130.800.056			

Pulse counters, electromechanical

Micro counters **High shock resistance (AC+DC)** **K 04 ... K 07 / AK 07**

PCB mount, lying
7-digit display on the top
Type K 07.90

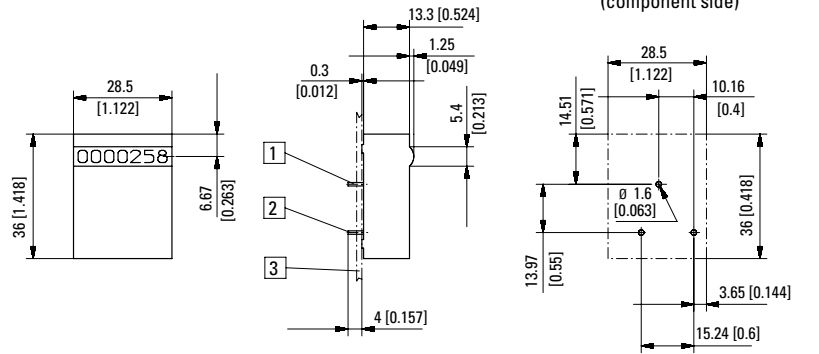

- 1) Mounting pin without el. function 0.4 x 1.2 [0.016 x 0.047]
 2) Coil connections 0.4 x 1.2 [0.016 x 0.047] 3) PCB

Type	Voltage	Display	Art. no.					
			3 V	4.5 V	12 V	24 V	115 V	230 V
K 07.90	DC (10 Hz) / 0	7 digits	1.130.900.006	1.130.900.008	1.130.900.012 ¹⁾	on request	1.130.900.054	1.130.900.056
	DC (25 Hz) / 1					1.130.900.033		
	AC (10 Hz) / a0					1.130.900.051		

Base mount, upright
7-digit display front side
Type AK 07.00

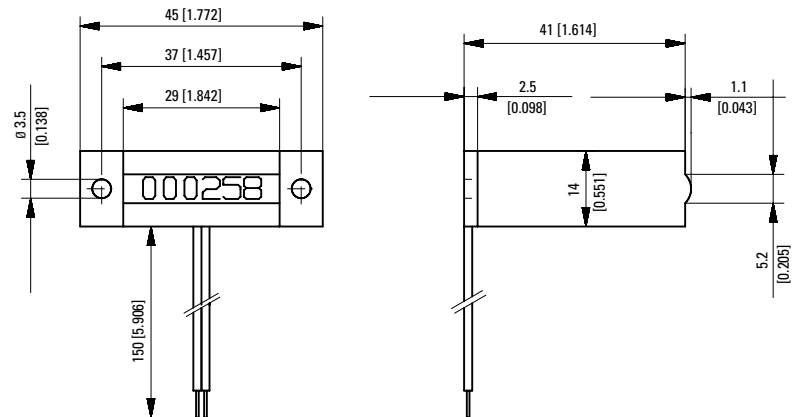

Type	Voltage	Display	Art. no.					
			3 V	4.5 V	12 V	24 V	115 V	230 V
AK 07.00	DC (10 Hz) / 0	7 digits	1.130.000.006	1.130.000.008	1.130.000.012	1.130.000.013	1.130.000.054	1.130.000.056 ¹⁾
	DC (25 Hz) / 1					1.130.000.033		
	AC (10 Hz) / a0					1.130.000.051		

Micro counters	High shock resistance, for DIN-rail (AC+DC)	SK 07
-----------------------	--	--------------

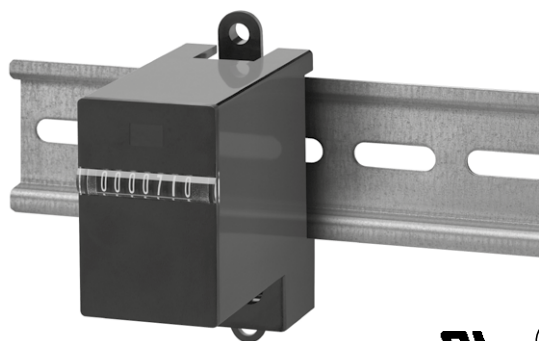

The micro-totalizers SK 07 boast a very high level of shock resistance.

Their DIN-rail mounting allows them to be installed quickly and easily in a wide range of application areas.

Characteristics

- 7-digit micro-totalizers.
- Rail mounting to EN 50022.
- Base mount counters.
- Large optical figures.
- Low power consumption.
- Small dimensions.

Benefits

- High shock resistance.
- Stores values if power fails.
- Long service life.

Applications

General quantity counting, installation in control cabinets and distribution boxes.

Type series

Description	Type	Order information
Base mounting and rail mounting	SK 07.1	<ul style="list-style-type: none"> • Art. no. • For options please give exact counter type, voltage and options e.g.: SK 07.1 – 9 V DC/0 – temperature range -20°C ... +70°C [-4°F ... +158°F]

Technical data

Electrical connection	clamp terminal for cable diameter up to 2.5 mm ² , tightening torque max. 0.8 Nm
Power consumption – at 20°C [68°F]	
at 10 Hz (type 0)	approx. 50 mW
at 25 Hz (type 1)	approx. 250 mW
at 10 Hz (type a0)	approx. 800 mVA
Rated voltage	
type 0	1.5/3/4.5/5/6/12 V DC, -10 %, +20 %
type 1	3/4.5/5/6/12/24 V DC, ±10 %
type a0	12/24/115/230 V AC, ±10 %
Counting frequency	max. 10 and 25 Hz
Pulse duration	
bei 10 Hz	min. 50 ms (type 0 and a0)
bei 25 Hz	min. 20 ms (type 1)
Cycle duration factor	100 %
Number of digits	7
Counting system	adding
Height of figures (optical)	4 x 1.2 mm [0.16 x 0.047"]
Color of figures	white on black
Reset	no reset
Operating temperature	-10°C ... +60°C [+14°F ... +140°F] (non-condensing)

Mounting position	horizontal, other on request
Operating life	> 50 x 10 ⁶ pulses
Protection	IP50 (front side)
Housing	plastic black PC (Polycarbonate)
Weight	55 g [1.94 oz]
EMC standards	EN 55011 class B EN 61000-6-2, EN 61000-6-3
Device safety	designed to EN 61010 part 1 protection class 2 application area pollution level 2
UL approval	file E128604

Options

- electrical connection: flat pin 0.8 x 6.3 mm [0.032 x 0.25"], Art. no.: 1.1X2.X01.XXX.011
- different voltages
- different digit colors
- different temperature range depends on type
-30°C ... +85°C [-22°F ... +185°F] or
-20°C ... +70°C [-4°F ... +158°F]

Product overview Basics
 Pulse counters
 Preset counters
 Hour meters Timers
 Frequency displays Tachometers
 Position displays
 Multifunction devices
 Energy meters
 Process devices
 Temperature devices
 Strain-gauge controllers
 Accessories Index

Pulse counters, electromechanical

Micro counters	High shock resistance, for DIN-rail (AC+DC)	SK 07
-----------------------	--	--------------

**Base- and rail mounting
Type SK 07.1**

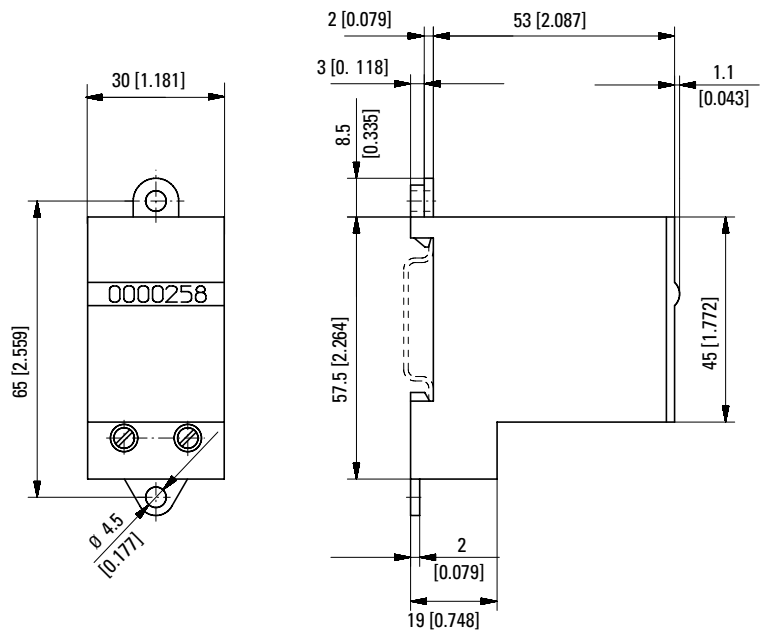
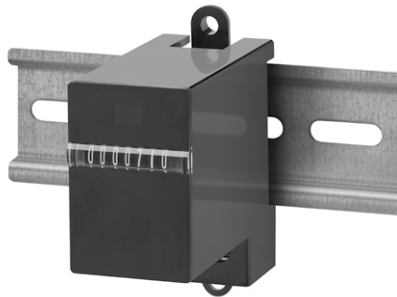

Type	Voltage	Display	Art. no.			
			12 V	24 V	115 V	230 V
SK 07.1	DC (10 Hz) / 0	7 digits	1.132.101.012	1.132.101.013 ¹⁾		
	DC (25 Hz) / 1		1.132.101.032	1.132.101.033 ¹⁾		
	AC (10 Hz) / a0			1.132.101.051 ¹⁾	1.132.101.054 ¹⁾	1.132.101.056 ¹⁾

Dimensions in mm [inch]

1) Stock types.

- Product overview
- Basics
- Pulse counters
- Preset counters
- Hour meters
- Timers
- Frequency displays
- Tachometers
- Position displays
- Multifunction devices
- Energy meters
- Process devices
- Temperature devices
- Strain-gauge controllers
- Accessories
- Index

Pulse counters, electromechanical

Mini counters	5 digits with reset (AC+DC)	W 15
----------------------	------------------------------------	-------------

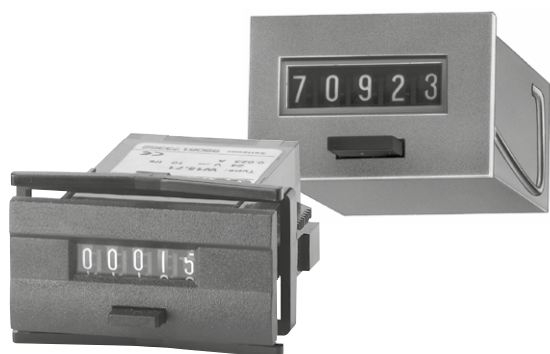

The mini totalizers W 15 are manually resettable and have been designed for various front panel sizes in a wide variety of applications.

They offer an excellent price / performance ratio and are easy to operate.



Characteristics

- 5-digit miniature pulse counter, adding with manual reset.
- Low power consumption.
- Available for all common DC and AC voltages.
- DIN housing 48 x 24 mm available.

Benefits

- Long service life (50 million pulses).
- Ideal for battery operation and electronic switching operations.

Applications

Machines and appliances, battery-powered devices, heat and water consumption measurement, establishing tolls and charges, general quantity counting.

Type series

Description	Panel mount dimensions	Housing	Display	Type	Order information
Panel mount with mounting clip, 34 x 23 mm [1.34 x 0.91"]	31 x 20 mm [1.22 x 0.79"]	plastic	front side	W 15.21	• Art. no. • For special voltages, please give type, voltage, kind of voltage and series e.g.: W 15.21, 4.5 V DC/0 black
Panel mount with mounting clip, 48 x 24 mm [1.89 x 0.94"]	45 x 22 mm [1.77 x 0.87"]	plastic	front side	W 15.51	

Accessories	Dimensions in mm [inch]	Order no.
Adapter front bezel, 53 x 28 [2.09 x 1.10]	for cut-out 50 x 25 [1.97 x 0.98] to cut-out 45 x 22.2 [1.77 x 0.87], with clip mounting for counters 48 x 24 [1.89 x 0.94]	anthracite T008180
Adapter front bezel, 56 x 40 [2.20 x 1.57]	for cut-out 50 x 25 [1.97 x 0.98] to cut-out 45 x 22.2 [1.77 x 0.87], with screw mounting for counters 48 x 24 [1.89 x 0.94]	anthracite T008181
Adapter front bezel, 72 x 36 [2.83 x 1.42]	for cut-out 68 x 33 [2.68 x 1.30] to cut-out 45 x 22.2 [1.77 x 0.87], for counters 48 x 24 [1.89 x 0.94], as set	black and silver anodised 162704 Set
Adapter front bezel, 48 x 48 [1.89 x 1.89]	for cut-out 45 x 45 [1.77 x 1.77] to cut-out 45 x 22.2 [1.77 x 0.87], with clip mounting for counters 48 x 24 [1.89 x 0.94]	black T008883
Adapter front bezel, 60 x 50 [2.36 x 1.97]	for cut-out 54 x 29 [2.13 x 1.14] to cut-out 45 x 22.2 [1.77 x 0.87], with screw mounting and gasket for counters 48 x 24 [1.89 x 0.94]	black N003001
Transparent cover, lockable, IP65	for cut-out 54 x 29 [2.13 x 1.14], for screw mounting to front bezel F1B or adapter front bezel N003001, for counters with cut-out 50 x 25 [1.97 x 0.98] or 45 x 22.2 [1.77 x 0.87]	N003002
Sealing cover type K1, IP65	suitable for front bezel 60 x 50 [2.36 x 1.97] for screw mounting of electromech. counters and via adapter front bezel N003001, for counters 48 x 24 [1.89 x 0.94]	G008301
Mounting frame with cut-out 50 x 25 [2.36 x 1.97] via separate adapter also for 45 x 22.2 [1.77 x 0.87]	for snap-on mounting on 35 [1.38] top-hat DIN rail, for counters 53 x 28 [2.09 x 1.10] and via separate adapter (T008180) for counters 48 x 24 [1.89 x 0.94]	chromated G300004

Suitable gaskets, other accessories and installation examples for optional accessories can be found in chapter accessories or in the accessories section under: www.kuebler.com/accessories.

Pulse counters, electromechanical

Mini counters **5 digits with reset (AC+DC)** **W 15**

Technical data		
Electrical connection	standard	flying leads, AWG 22 approx. 150 mm [5.91"] \varnothing 0.34 mm ² , 6 mm [0.24"] stripped wire ends, tinned
Rated voltage	type 05 (8 Hz) type 0 (10 Hz) type a0 (10 Hz)	1.5 / 3 / 4.5 / 5 / 6 / 12 V DC (+15 %, -5 %) 12 / 24 / 48 / 115 / 230 V DC \pm 10 % 12 / 24 / 48 / 115 / 230 V AC, \pm 10 %
Cycle duration factor		100 %
Height of figures		approx. 4 x 1.7 mm [0.16 x 0.067"]
Color of figures		white on black
Counting mechanism shaft		stainless steel
Operating temperature		-10°C ... +50°C [+14°F ... +122°F] (non-condensing)
Mounting position		any
Operating life		> 50 x 10 ⁶ pulses
Protection		IP40 (front side)
Weight		approx. 52 g [1.83 oz]
EMC standards		EN 55011 class B EN 61000-6-2, EN 61000-6-3
Device safety	designed to protection class application area	EN 61010 part 1 2 pollution level 2

Options	
Electrical connection	<ul style="list-style-type: none"> pin \varnothing 1.5 mm with push on connectors (Art. no.: 1.151.X1X.XXX) with flat pin 0.8 x 2.8 mm [0.032 x 0.11"] and flat push on connectors (Art. no.: 1.159.X1X.XXX) with flat pin 0.8 x 6.3 mm [0.032 x 0.25"] and flat push on connectors (Art. no.: 1.155.XXX.XXX) with screw terminal (Art. no.: 1.154.XXX.XXX.023)
Color of housing (availability see table)	grey Art. no.: X.XXX.XX0.XXX black Art. no.: X.XXX.XX1.XXX
Extended temperature range	on request

Connection diagram

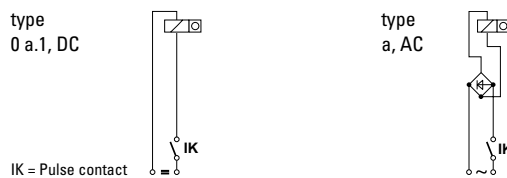

Type / Counting mechanism						
Voltage	Type	Pulse frequency max.	Pulse on time min.	Pulse interval min.	Power consumption approx.	Permi. residual ripple max.
V DC	05	8 Hz	50 ms	75 ms	130 mW	5 %
V DC	0	10 Hz	50 ms	50 ms	0.5 W (\leq 115 V) 1 W (185 V)	48 %
V AC	a0	10 Hz	50 ms	50 ms	0.75 VA (\leq 115 V) 1.5 VA (230 V)	—

Panel mount with mounting clip
Panel mount dimensions 31 x 20 [1.22 x 0.79]
Type W 15.21

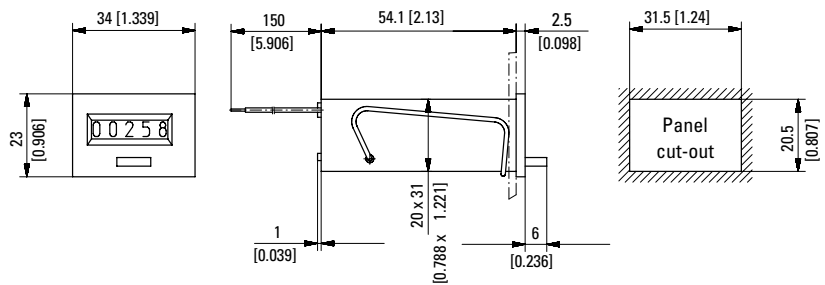

Color of housing black: Art. no. 1.150.211.XXX

Type	Voltage	Display	Art. no.				Further stock types:
			12 V	24 V	115 V	230 V	
W 15.21	DC (8 Hz) / 05	5 digits	1.150.210.049	1.150.210.050			1.150.211.012 12 V DC/0 sw 1.150.211.013 24 V DC/0 sw 1.150.211.056 230 V AC/a0 sw
	DC (10 Hz) / 0		1.150.210.012	1.150.210.013 ¹⁾			
	AC (10 Hz) / a0			1.150.210.051	1.150.210.054	1.150.210.056 ¹⁾	

Pulse counters, electromechanical

Mini counters

5 digits with reset (AC+DC)

W 15

Panel mount with mounting clip

Panel mount dimensions 45 x 22 [1.77 x 0.87]

Type W 15.51

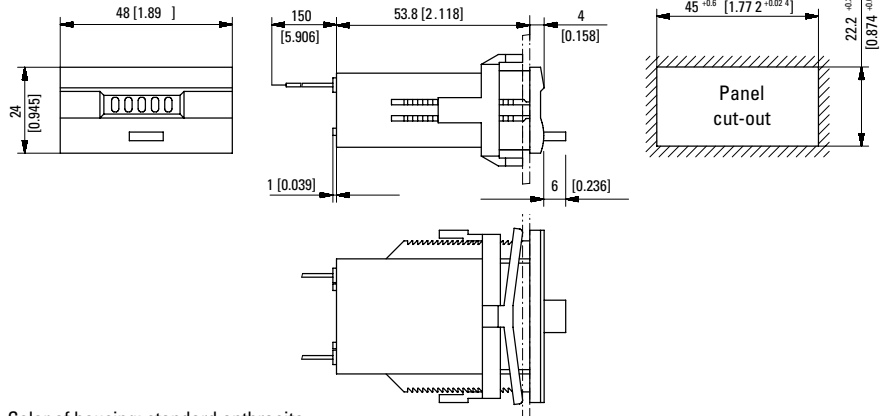

Color of housing: standard anthracite

Type	Voltage	Display	Art. no.			
			12 V	24 V	115 V	230 V
W 15.51	DC (8 Hz) / 05	5 digits	1.150.510.049.550	1.150.510.050.550		
	DC (10 Hz) / 0		1.150.510.012.550 ¹⁾	1.150.510.013.550 ¹⁾		
	AC (10 Hz) / a0			1.150.510.051.550	1.150.510.054.550 ¹⁾	1.150.510.056.550 ¹⁾

Pulse counters, electromechanical

Mini counters	6 or 7 digits without reset (AC+DC)	W 16 / W 17
----------------------	--	--------------------



The mini totalizers W 16 and W 17 are not resettable, and have been designed for various front panel sizes in a wide variety of applications.

They offer an excellent price / performance ratio and are easy to operate.

Product overview
Basics

Pulse counters

Preset counters

Hour meters
Timers

Frequency displays
Tachometers

Position displays

Multifunction
devices

Energy meters

Process devices

Temperature
devices

Strain-gauge
controllers

Accessories
Index

<h3>Characteristics</h3> <ul style="list-style-type: none"> 6- or 7-digit miniature pulse counters, adding without reset. Low power consumption. Available for all common DC and AC voltages. Versions available for DIN 48 x 24 mm and many other panel mount dimensions as well as for other types, e.g. PCB mount. 	<h3>Benefits</h3> <ul style="list-style-type: none"> Long service life / Protection IP41 (front side).
	<h3>Applications</h3> <p>Battery-powered devices, heat and water consumption measurement, establishing tolls and charges, general quantity counting.</p>

Type series					
Description / mounting	Panel mount dim.	Housing	Display	6 digits	7 digits
Panel mount + mounting clip, 34 x 23 mm [1.34 x 0.91"]	31 x 20 mm [0.79 x 0.25"]	plastic	front side	W 16.20	-
Panel mount + mounting clip, 48 x 24 mm [1.89 x 0.94"]	45 x 22.2 mm [1.77 x 0.87"]	plastic	front side	-	W 17.50
PCB mount, lying		sheet steel	on the top	W 16.60	-
Panel mount + mounting clip, 42 x 28 mm [1.65 x 1.10"]	37.5 x 23.5 mm [1.48 x 0.93"]	plastic	front side	-	W 17.90
Order information					
· Art. no.					
· For special voltages, please give type, voltage, kind of voltage and series e.g.: W 16.20, 9 V DC, 05, black					

Accessories	Dimensions in mm [inch]	Order no.
Adapter front bezel, 53 x 28 [2.09 x 1.10]	for cut-out 50 x 25 [1.97 x 0.98] to cut-out 45 x 22.2 [1.77 x 0.87], with clip mounting for counters 48 x 24 [1.89 x 0.94]	anthracite T008180
Adapter front bezel, 56 x 40 [2.20 x 1.57]	for cut-out 50 x 25 [1.97 x 0.98] to cut-out 45 x 22.2 [1.77 x 0.87], with screw mounting for counters 48 x 24 [1.89 x 0.94]	anthracite T008181
Adapter front bezel, 72 x 36 [2.83 x 1.42]	for cut-out 68 x 33 [2.68 x 1.30] to cut-out 45 x 22.2 [1.77 x 0.87], for counters 48 x 24 [1.89 x 0.94], as set	black and silver anodised 162704 Set
Adapter front bezel, 48 x 48 [1.89 x 1.89]	for cut-out 45 x 45 [1.77 x 1.77] to cut-out 45 x 22.2 [1.77 x 0.87], with clip mounting for counters 48 x 24 [1.89 x 0.94]	black T008883
Adapter front bezel, 60 x 50 [2.36 x 1.97]	for cut-out 54 x 29 [2.13 x 1.14] to cut-out 45 x 22.2 [1.77 x 0.87], with screw mounting and gasket for counters 48 x 24 [1.89 x 0.94]	black N003001
Transparent cover, lockable, IP65	for cut-out 54 x 29 [2.13 x 1.14], for screw mounting to front bezel F1B or adapter front bezel N003001, for counters with cut-out 50 x 25 [1.97 x 0.98] or 45 x 22.2 [1.77 x 0.87]	N003002
Sealing cover type K1, IP65	suitable for front bezel 60 x 50 [2.36 x 1.97], for screw mounting of electromech. counters and via adapter front bezel N003001 for counters 48 x 24 [1.89 x 0.94]	G008301
Mounting frame with cut-out 50 x 25 [2.36 x 1.97] via separate adapter also for 45 x 22.2 [1.77 x 0.87]	for snap-on mounting on 35 [1.38] top-hat DIN rail, for counters 53 x 28 [2.09 x 1.10] and via separate adapter (T008180) for counters 48 x 24 [1.89 x 0.94]	chromated G300004

Suitable gaskets, other accessories and installation examples for optional accessories can be found in chapter accessories or in the accessories section under: www.kuebler.com/accessories.

Pulse counters, electromechanical

Mini counters	6 or 7 digits without reset (AC+DC)	W 16 / W 17
----------------------	--	--------------------

Technical data		
Electrical connection	panel mount, base mount	flying leads, AWG 22 approx. 150 mm [5.91"] \varnothing 0.34 mm ² , 6 mm [0.24"] stripped wire ends, tinned round pin \varnothing 1.6 mm [0.063"]
	PCB mount	
Rated voltage	type 05 (8 Hz)	1.5 / 3 / 4.5 / 5 / 6 / 12 V DC (+15 %, -5 %)
	type 0 (10 Hz)	12 / 24 / 48 / 115 / 230 V DC \pm 10 %
	type a0 (10 Hz)	24 / 48 / 115 / 230 V AC, \pm 10 %
Cycle duration factor		100 %
Height of figures		4 x 1.7 mm [0.16 x 0.067"]
Color of figures		white on black
Counting mechanism shaft		stainless steel
Operating temperature		-10°C ... +50°C [+14°F ... +122°F] (non-condensing)
Mounting position		any
Operating life		> 50 x 10 ⁶ pulses
Protection		IP41 (front side)
Weight		approx. 50 g [1.76 oz]
EMC standards		EN 55011 class B EN 61000-6-2, EN 61000-6-3
Device safety	designed to	EN 61010 part 1
	protection class application area	2 pollution level 2

Options		
Electrical connection	round pins \varnothing 1.6 mm [0.063"] and push on connectors	(Art. no.: 1.161.XXX.XXX)
	with flat pin 0.8 x 2.8 mm [0.032 x 0.11"]	(Art. no.: 1.169.XXX.XXX)
	with flat pin 0.8 x 6.3 mm [0.032 x 0.25"] and push on connectors	(Art. no.: 1.165.XXX.XXX)
	with open screw terminals	(Art. no.: 1.164.XXX.XXX.023)
Color of housing (availability see table)	grey	Art. no.: X.XXX.XX0.XXX
	black	Art. no.: X.XXX.XX1.XXX
Extended temperature range		on request
With lens for digit height 5 or 6.3 mm		on request

Connection diagram

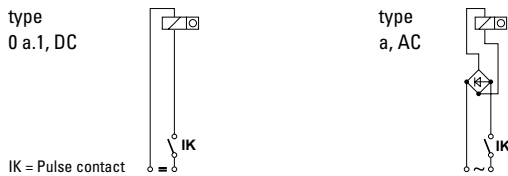

Type / Counting mechanism						
Voltage	Type	Pulse frequency max.	Pulse on time min.	Pulse interval min.	Power consumption approx.	Permi. residual ripple max.
V DC	05	8 Hz	50 ms	75 ms	50 mW	5 %
V DC	0	10 Hz	50 ms	50 ms	0.5 W (\leq 115 V) 1 W (185 V)	48 %
V AC	a0	10 Hz	50 ms	50 ms	0.75 VA (\leq 115 V) 1.5 VA (230 V)	—

Panel mount with mounting clip

Panel mount dimensions 31 x 20 [1.22 x 0.79]

Type W 16.20

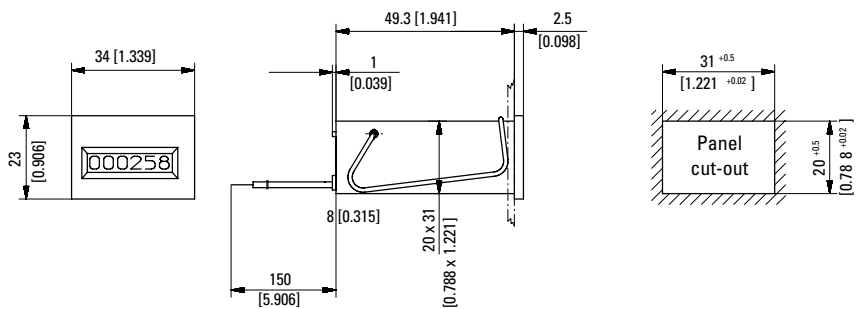

Color of housing black: Art. no. 1.160.201.XXX

Type	Voltage	Display	Art. no.			Further stock types: 1.160.201.013 24 V DC/0sw 1.160.201.056 230 V AC/a0sw
			12 V	24 V	115 V	
W 16.20	DC (8 Hz) / 05	6 digits	1.160.200.049	1.160.200.050		
	DC (10 Hz) / 0		1.160.200.012	1.160.200.013 ¹⁾		
	AC (10 Hz) / a0			1.160.200.051	1.160.200.054	1.160.200.056 ¹⁾

Pulse counters, electromechanical

Mini counters **6 or 7 digits without reset (AC+DC)** **W 16 / W 17**

Panel mount with mounting clip 48 x 24 [1.89 x 0.94]
 Panel mount dimensions 45 x 22.2 [1.77 x 0.87]

Type W 17.50

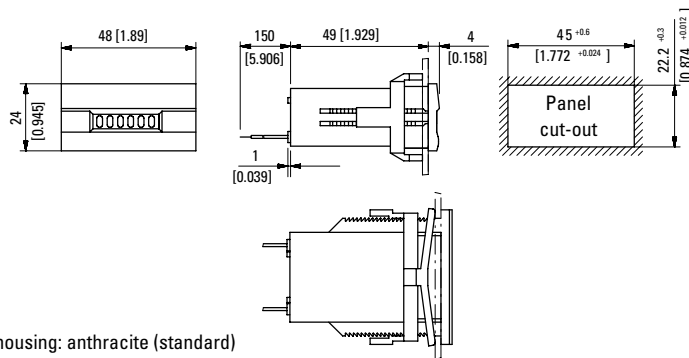

Color of housing: anthracite (standard)

Type	Voltage	Display	Art. no.			
			12 V	24 V	115 V	230 V
W 17.50	DC (8 Hz) / 05	7 digits	1.740.500.049.550	1.740.500.050.550		
	DC (10 Hz) / 0		1.740.500.012.550¹⁾	1.740.500.013.550¹⁾		
	AC (10 Hz) / a0			1.740.500.051.550	1.740.500.054.550	1.740.500.056.550¹⁾

PCB mount, sheet steel

Display wide side

Type W 16.60

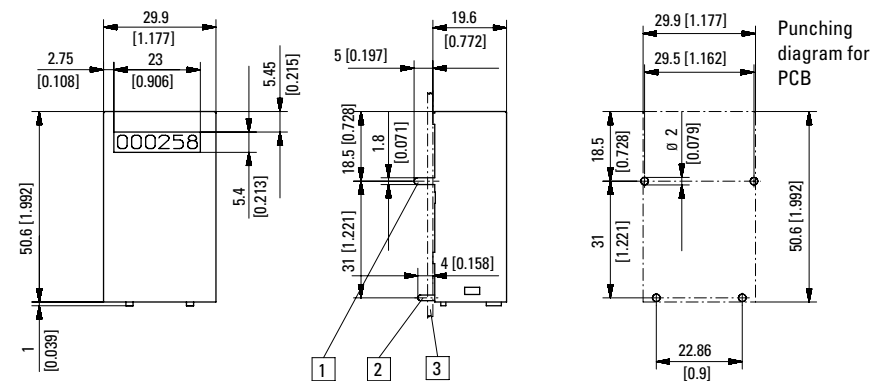

1) Mounting pins 1.8 x 0.4 [0.071 x 0.016] 2) Coil connections ø 0.16 [0.006] 3) PCB

Color of housing blue (zinc-plated)

Type	Voltage	Display	Art. no.			
			12 V	24 V	115 V	230 V
W 16.60	DC (10 Hz) / 0	6 digits	1.160.601.012	1.160.601.013		

Panel mount with mounting clip

Panel mount dimensions 37.5 x 23.5 [1.48 x 0.93]

Type W 17.90

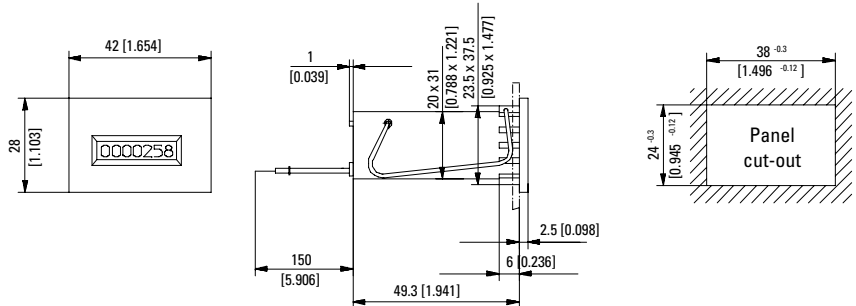
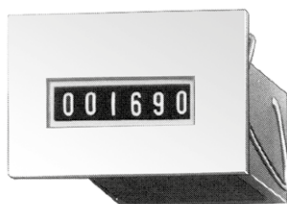

Color of housing black: Art. no. 1.XXX.901.XXX

Type	Voltage	Display	Art. no.			
			12 V	24 V	115 V	230 V
W 17.90	DC (8 Hz) / 05	7 digits	1.740.900.049	1.740.900.050		
	DC (10 Hz) / 0		1.740.900.012	1.740.900.013		
	AC (10 Hz) / a0				1.740.900.054	1.740.900.056

Dimensions in mm [inch]

1) Stock types

Pulse counters, electromechanical

Standard counters

4 digits with reset (AC+DC)

Bk 14



The standard totalizers Bk 14 (with manual reset) boast a robust construction despite their small size.

They are ideal for use in harsh industrial environments.

Characteristics

- 4-digit totalizer with manual reset.

Benefits

- Very long service life (200 million pulses).

Applications

General quantity counting, time, charge and performance metering.

Type series

Description	Type	Order information
Panel mount with 2 mounting holes	Bk 14.11	· Art. no.
Panel mount for clip mounting	Bk 14.21	· At different voltages, please give type, voltage, kind of voltage and series e.g.: Bk 14.21, 12 V AC, type a

Technical data	
Electrical connection	tinned round pins \varnothing 1.6 mm [0.063"] with push on connectors
Rated voltage	type 0/l/a 12 / 24 / 48 / 115 / 230 V DC \pm 10 % 24 / 48 / 115 / 230 V AC \pm 10 %
Color of counter	grey
Height of figures	approx. 2 x 4 mm [0.079 x 0.16"]
Color of figures	white on black
Counting mechanism shaft	stainless steel
Mounting position	any
Operating life	approx. 200 x 10 ⁶ pulses
Protection	IP40 (front side)
Weight	70 g [2.47 oz]
Test voltage	2000 V ~ effective, acc. to VDE 0435
Vibration resistance	3 g up to 10 Hz 6 g up to 15 Hz independent of position 10 g 20 - 300 Hz

EMC standards	EN 55011 class B EN 61000-6-2, EN 61000-6-3
Device safety	designed to protection class 2 application area EN 61010 part 1 pollution level 2

Options

- key locking reset special key (order code "vs", e.g. Bk 14.11 vs)
- housing color black
- higher counting speed
- also with flying leads

Connection diagram

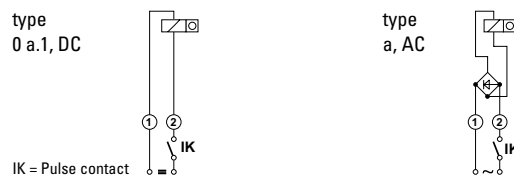

Type / Counting mechanism										
Voltage	Type	Pulse frequency max.	Pulse on time min.	Pulse interval min.	Pulse ratio	On-time	Power consump. approx.	Permi. residual ripple max.	Operating temp. (non-condensing)	
V DC	0	10 Hz	60 ms	40 ms	3 : 2	100 %	1 W	48 %	-10°C ... +60°C [+14°F ... +140°F]	
V DC	1	25 Hz	24 ms	16 ms	3 : 2	100 %	2 W	48 %	-10°C ... +60°C [+14°F ... +140°F]	
V AC	a	18 Hz	22.2 ms	33.3 ms	2 : 3	100 %	2.9 VA	—	-10°C ... +55°C [+14°F ... +131°F]	

Pulse counters, electromechanical

Standard counters **4 digits with reset (AC+DC)** **Bk 14**

Panel mount with 2 mounting holes
4 digits, with reset

Type Bk 14.11

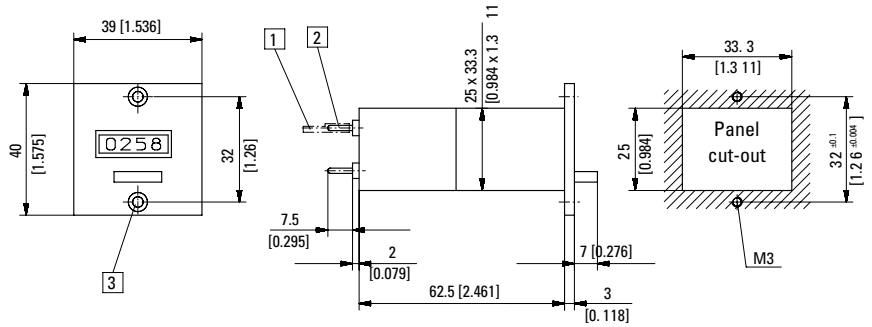

1 Push on connector \varnothing 1.5 [0.059], tinned 2 Round pin \varnothing 1.6 [0.063], tinned 3 Countersinking Af3 DIN 94

Type	Voltage	Display	Art. no.			
			12 V	24 V	115 V	230 V
Bk 14.11	DC (10 Hz) / 0	4 digits	1.180.110.012	1.180.110.013 ¹⁾		
	DC (25 Hz) / 1		1.180.110.032	1.180.110.033		
	AC (18 Hz) / a		1.180.110.061	1.180.110.064	1.180.110.066	

Panel mount for clip mounting
4 digits, with reset

Type Bk 14.21

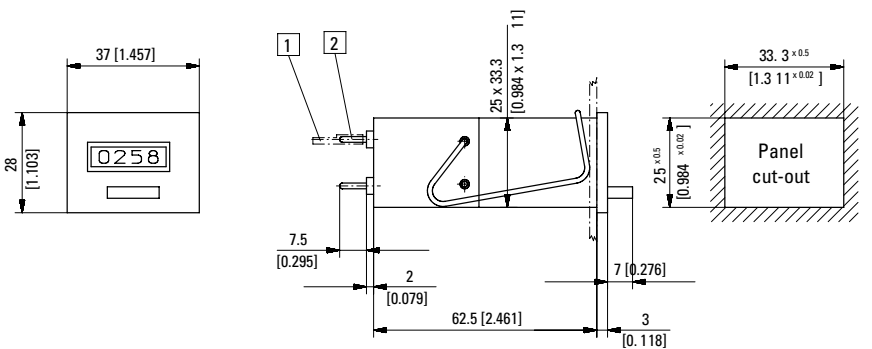

1 Push on connector \varnothing 1.5 [0.059], tinned 2 Round pin \varnothing 1.6 [0.063], tinned

Type	Voltage	Display	Art. no.			
			12 V	24 V	115 V	230 V
Bk 14.21	DC (10 Hz) / 0	4 digits	1.180.210.012	1.180.210.013		
	DC (25 Hz) / 1		1.180.210.032	1.180.210.033		
	AC (18 Hz) / a		1.180.210.061	1.180.210.064	1.180.210.066	

Product overview
Basics
Pulse counters
Preset counters
Hour meters
Timers
Frequency displays
Tachometers
Position displays
Multifunction devices
Energy meters
Process devices
Temperature devices
Strain-gauge controllers
Accessories
Index

Pulse counters, electromechanical

Standard counters	6 or 8 digits with/without reset (AC+DC)	B 16 / B 18
--------------------------	---	--------------------



The standard totalizers **B 16** (with manual reset) and **B 16, B 18** (without reset) offer a robust construction.

They are ideal for use in harsh industrial environments as individual counters or as plug-in types in combination with additional **B, BVa, HB or HVa** counters.

Characteristics

- B 16.x1: 6-digit totalizer with manual reset.
- B 16.x0 and B 18.x0: 6- and 8-digit totalizers without reset.
- Counters without front bezel fit into bezels F1B and F2B and can be combined in RM 50 x 25 mm with socket 945.2.
- Very long service life (200 million pulses).

Benefits

- Can be combined with preset counters BVa and HVa, as well as with timer HB.
- Can be upgraded using various front covers to protect against dust, dirt and humidity – reset can be locked out.

Applications

General quantity counting, piece counting, event counting, timing.

Type series

Description	6 digits without reset	8 digits without reset	6 digits with reset	Order information
Counter without front bezel, rear mounting, plugs into socket box 945.2 and frontbezel F1	–	B 18.00	B 16.01	- Art. no. - For special voltages, please give type, voltage, kind of voltage and series e.g.: B 16.31, 4.5 V DC, 0 or B 18.00, 48 V AC, a
Panel mount, front bezel size no. 1 with 2 mounting holes	B 16.10	B 18.10	B 16.11	
Panel mount, for clip mounting	B 16.20	B 18.20	B 16.21	
Panel mount, front bezel size no. 3 with 2 mounting holes	B 16.30	B 18.30	B 16.31	

Accessories	Dimensions in mm [inch]	Order no.
Front bezel, type F1B plastic	for cut-out 54 x 49 [2.13 x 1.93], for screw mounting, for plug-in counters B1x.0x and HB2x.0x in socket box type 945.2	beige G007501 black G007502
Socket box, type 945.2	for counters B1x.0x and HB2x.0x, can be used for plug-in connections in front bezel F1B	black G008434
Sealing cover, type K1, IP65	for front bezel 60 x 50 [2.36 x 1.97], with screw mounting, for electromechanical counters and via adapter front bezel N003001 for counters 48 x 24 [1.89 x 0.94]	transparent / grey G008300 transparent / black G008301
Transparent cover, lockable, IP65	for cut-out 54 x 29 [2.13 x 1.14], for screw mounting to front bezel F1B or adapter front bezel N003001, for counters with cut-out 50 x 25 [1.97 x 0.98] or 45 x 22.2 [1.77 x 0.87]	N003002
Blind enclosure, 53 x 28 [2.07 x 1.10]	for cut-out 50 x 25 [1.97 x 0.98], for counters 53 x 28 [2.09 x 1.10]	black T005753
Mounting frame with cut-out 50 x 25 [2.36 x 1.97] via separate adapter also for 45 x 22.2 [1.77 x 0.87]	for snap-on mounting on 35 [1.38] top-hat DIN rail, for counters 53 x 28 [2.09 x 1.10] and via separate adapter (T008180) for counters 48 x 24 [1.89 x 0.94]	chromated G300004
Mounting rail frame SR	for B and HB counters for snap-on mounting on 35 [1.38] top-hat DIN rail	SR 1 for 1x3 B counters G300000 SR 2 for 2x3 B counters G300001
Transparent cover, replacement part, IP65	screw-on, IP65 with gaskets and screws suitable for Dv(s)B1x and Dv(s)HB2x	type Dv, lockable G008121 type Dvs, key lockable G008131

Suitable gaskets, other accessories and installation examples for optional accessories can be found in chapter accessories or in the accessories section under: www.kuebler.com/accessories.

Pulse counters, electromechanical

Standard counters 6 or 8 digits with/without reset (AC+DC) B 16 / B 18

Technical data		
Electrical connection	count mechanism	pin \varnothing 1.6 mm [0.063] with push on connector for flying leads 0.5 ... 1.0 mm ²
	socket box	flat pin 0.8 x 2.8 mm [0.032 x 0.11"]
Rated voltage	type 0 / 1 / a	12 / 24 / 48 / 115 / 230 V DC \pm 10 % 24 / 48 / 115 / 230 V AC \pm 10 %
Color of counter		grey
Height of figures	B 16	2 x 4.5 mm [0.079 x 0.18]
	B 18	2 x 4 mm [0.079 x 0.16]
Color of figures		white on black
Count mechanism shaft		stainless steel
Mounting position		any
Operating life		approx. 200 x 10 ⁶ pulses
Protection	with reset	IP40 (front side)
	without reset	IP41 (front side)
Weight	without reset	81 g [2.86 oz]
	with reset	83 g [2.93oz]
	socket box	14 g [0.49 oz]
Test voltage		2000 V ~ effective, acc. to VDE 0435
EMC standards		EN 55011 class B EN 61000-6-2, EN 61000-6-3
Device safety	designed to protection class	EN 61010 part 1 2
	application area	pollution level 2

Options	
Color of housing black	Art. no. ref. to type 1.XXX.XX1.XXX
Electr. connection at counter	flat pins 0.8 x 2.8 mm [0.032 x 0.11"] with push on connectors Art. no. 1.XX7.XXX.XXX
Counter with flat pin 6.3 x 0.8 mm [0.25 x 0.032"]	on request 1.XXX.XXX.XXX.011
Screw terminal	Art. no. 1.XXX.XXX.XXX.023
Connection with flying leads	on request 1.XX3.XXX.XXX
Extended temperature range	on request
Key locking reset	grey 1.XXX.XX6.XXX
	black 1.XXX.XX7.XXX
	key for reset G050265 (replacement part)



Connection diagram

type 0 a.1, DC

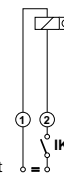

type a, AC

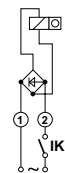

IK = Pulse contact

Type / Counting mechanism									
Voltage	Type	Pulse frequency max.	Pulse on time min.	Pulse interval min.	Pulse ratio	On-time	Power consump. approx.	Permi. residual ripple max.	Operating temp. (non-condensing)
V DC	0	10 Hz	60 ms	40 ms	3 : 2	100 %	1 W	48 %	-10°C ... +60°C [+14°F ... +140°F]
V DC	1	25 Hz	24 ms	16 ms	3 : 2	100 %	2 W	48 %	-10°C ... +60°C [+14°F ... +140°F]
V AC	a	18 Hz	22.2 ms	33.3 ms	2 : 3	100 %	2.9 VA	-	-10°C ... +55°C [+14°F ... +131°F]

Without front bezel, rear mounting

6 digits, with reset

Type B 16.01

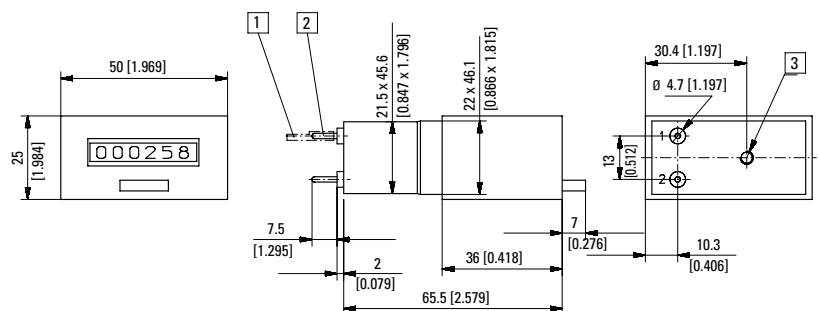

1 Push on connector \varnothing 1.5 [0.059], tinned 2 Round pin \varnothing 1.6 [0.063], tinned 3 M4, 5 [0.20] deep
Color of housing: beige (standard) – black, Art. no. 1.230.XX1.XXX

Type	Voltage	Display	Art. no.			
			12 V	24 V	115 V	230 V
B 16.01	DC (10 Hz) / 0	6 digits,	1.230.012.012	1.230.012.013		
	DC (25 Hz) / 1	with reset	1.230.012.032	1.230.012.033		
	AC (18 Hz) / a			1.230.012.061	1.230.012.064	1.230.012.066

Dimensions in mm [inch]

Pulse counters, electromechanical

Standard counters

6 or 8 digits with/without reset (AC+DC)

B 16 / B 18

Panel mount with front bezel size no. 1 and 2 mounting holes

6 digits, without reset

Type B 16.10

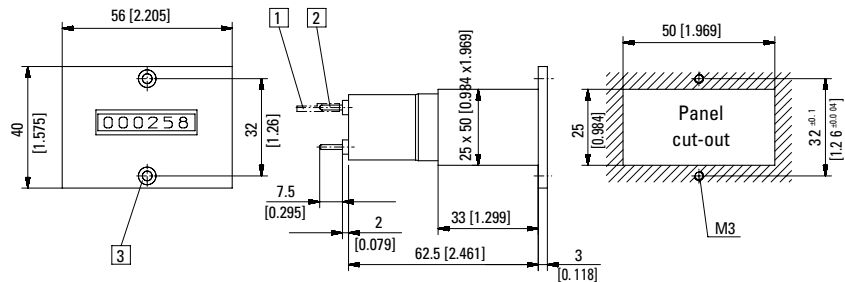

1 Push on connector \varnothing 1.5 [0.059], tinned 2 Round pin \varnothing 1.6 [0.063], tinned 3 Countersinking Af3 DIN 74
Color of housing: grey (standard) – black, Art. no. 1.230.101.XXX

Type	Voltage	Display	Art. no.			
			12 V	24 V	115 V	230 V
B 16.10	DC (10 Hz) / 0	6 digits, without reset	1.230.100.012	1.230.100.013		
	DC (25 Hz) / 1		1.230.100.032	1.230.100.033		
	AC (18 Hz) / a			1.230.100.061	1.230.100.064	1.230.100.066

Panel mount front bezel size no. 1 with 2 mounting holes

6 digits, with reset

Type B 16.11

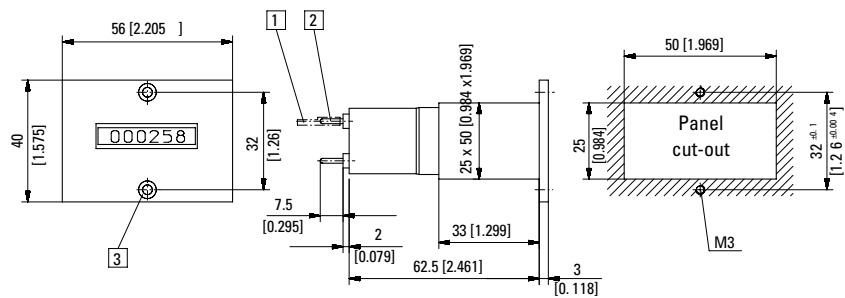

1 Push on connector \varnothing 1.5 [0.059], tinned 2 Round pin \varnothing 1.6 [0.063], tinned 3 Countersinking Af3 DIN 74
Color of housing: grey (standard) – black, Art. no. 1.230.111.XXX

Type	Voltage	Display	Art. no.			
			12 V	24 V	115 V	230 V
B 16.11	DC (10 Hz) / 0	6 digits, with reset	1.230.110.012	1.230.110.013		
	DC (25 Hz) / 1		1.230.110.032	1.230.110.033 ¹⁾		
	AC (18 Hz) / a			1.230.110.061 ¹⁾	1.230.110.064	1.230.110.066 ¹⁾

Panel mount for clip mounting

6 digits, without reset

Type B 16.20

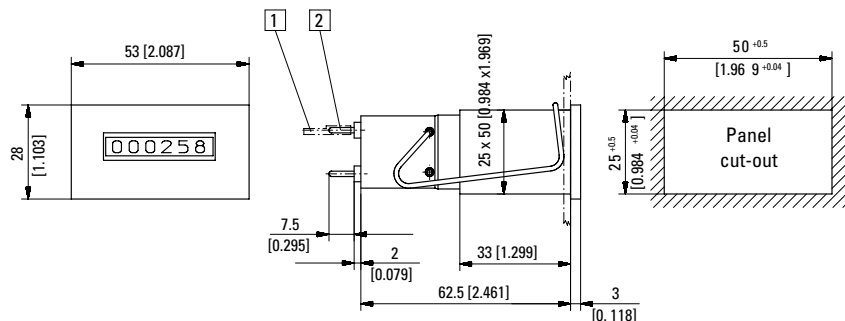

1 Push on connector \varnothing 1.5 [0.059], tinned 2 Round pin \varnothing 1.6 [0.063], tinned
Color of housing: grey (standard) – black, Art. no. 1.230.201.XXX

Type	Voltage	Display	Art. no.				Further stock types:
			12 V	24 V	115 V	230 V	
B 16.20	DC (10 Hz) / 0	6 digits, without reset	1.230.200.012	1.230.200.013			1.237.201.066 230 V AC/a with flat pins
	DC (25 Hz) / 1		1.230.200.032	1.230.200.033 ¹⁾			
	AC (18 Hz) / a			1.230.200.061	1.230.200.064	1.230.200.066	

Dimensions in mm [inch]

1) Stock types.

Pulse counters, electromechanical

Standard counters **6 or 8 digits with/without reset (AC+DC)** **B 16 / B 18**

Panel mount for clip mounting
6 digits, with reset
Type B 16.21

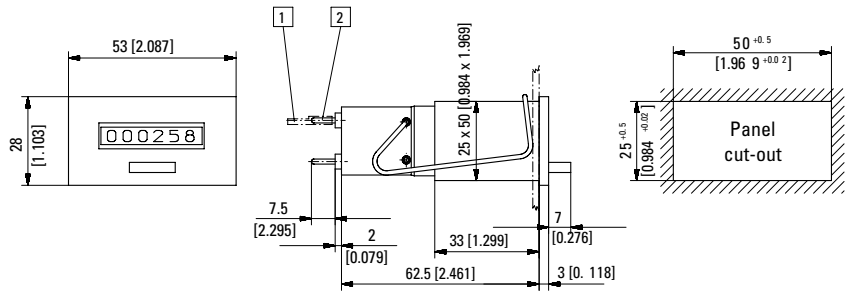

1) Push on connector \varnothing 1.5 [0.059], tinned 2) Round pin \varnothing 1.6 [0.063], tinned
Color of housing: grey (standard) – black, Art. no. 1.230.211.XXX

Type	Voltage	Display	Art. no.				Further stock types: (flat pins)
			12 V	24 V	115 V	230 V	
B 16.21	DC (10 Hz) / 0	6 digits, with reset	1.230.210.012	1.230.210.013 ¹⁾	1.230.210.064	1.230.210.066 ¹⁾	1.230.211.033 24 V DC/1 sw 1.230.217.013 24 V DC/0 sw vs 1.237.211.066 230 V AC/a sw
	DC (25 Hz) / 1		1.230.210.032	1.230.210.033 ¹⁾			
	AC (18 Hz) / a						

Panel mount with front bezel size no. 3 and 2 mounting holes
6 digits, without reset
Type B 16.30

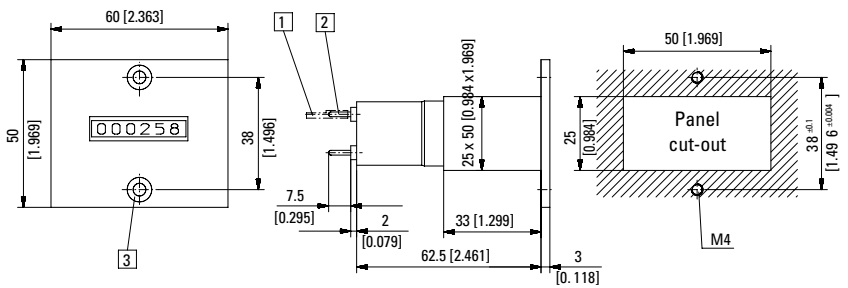

1) Push on connector \varnothing 1.5 [0.059], tinned 2) Round pin \varnothing 1.6 [0.063], tinned 3) Countersinking Am 4 DIN 74
Color of housing: grey (standard) – black, Art. no. 1.230.301.XXX

Type	Voltage	Display	Art. no.			
			12 V	24 V	115 V	230 V
B 16.30	DC (10 Hz) / 0	6 digits, without reset	1.230.300.012	1.230.300.013	1.230.300.064	1.230.300.066
	DC (25 Hz) / 1		1.230.300.032	1.230.300.033		
	AC (18 Hz) / a					

Panel mount with front bezel size no. 3 and 2 mounting holes
6 digits, with reset
Type B 16.31

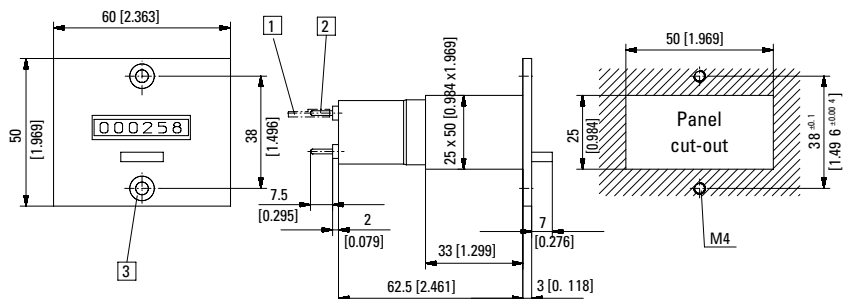

1) Push on connector \varnothing 1.5 [0.059], tinned 2) Round pin \varnothing 1.6 [0.063], tinned 3) Countersinking Bf 4 DIN 74
Color of housing: grey (standard) – black, Art. no. 1.230.111.XXX

Type	Voltage	Display	Art. no.			
			12 V	24 V	115 V	230 V
B 16.31	DC (10 Hz) / 0	6 digits, with reset	1.230.310.012	1.230.310.013	1.230.310.064	1.230.310.066
	DC (25 Hz) / 1		1.230.310.032	1.230.310.033		
	AC (18 Hz) / a					

Dimensions in mm [inch]

1) Stock types.

Pulse counters, electromechanical

Standard counters **6 or 8 digits with/without reset (AC+DC)** **B 16 / B 18**

Without front bezel, rear mounting
8 digits, without reset

Type B 18.00

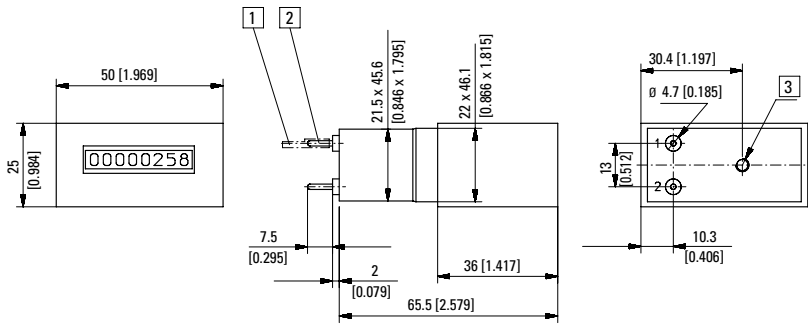

1 Push on connector \varnothing 1.5 [0.059], tinned 2 Round pin \varnothing 1.6 [0.063], tinned 3 M4, 5 [0.20] deep
Color of housing: beige (standard) – black, Art. no. 1.260.XX1.XXX

Type	Voltage	Display	Art. no.			
			12 V	24 V	115 V	230 V
B 18.00	DC (10 Hz) / 0	8 digits, without reset	1.260.002.012	1.260.002.013		
	DC (25 Hz) / 1		1.260.002.032	1.260.002.033 ¹⁾		
	AC (18 Hz) / a			1.260.002.061	1.260.002.064	1.260.002.066

Panel mount with front bezel size no. 1 and 2 mounting holes
8 digits, without reset

Type B 18.10

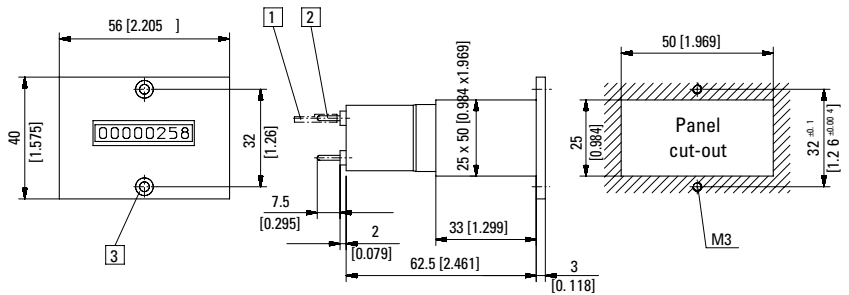
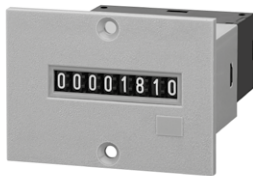

1 Push on connector \varnothing 1.5 [0.059], tinned 2 Round pin \varnothing 1.6 [0.063], tinned 3 Countersinking Af3 DIN 74
Color of housing: grey (standard) – black, Art. no. 1.260.101.XXX

Type	Voltage	Display	Art. no.			
			12 V	24 V	115 V	230 V
B 18.10	DC (10 Hz) / 0	8 digits, without reset	1.260.100.012	1.260.100.013 ¹⁾		
	DC (25 Hz) / 1		1.260.100.032	1.260.100.033		
	AC (18 Hz) / a			1.260.100.061	1.260.100.064	1.260.100.066

Panel mount for clip mounting
8 digits, without reset

Type B 18.20

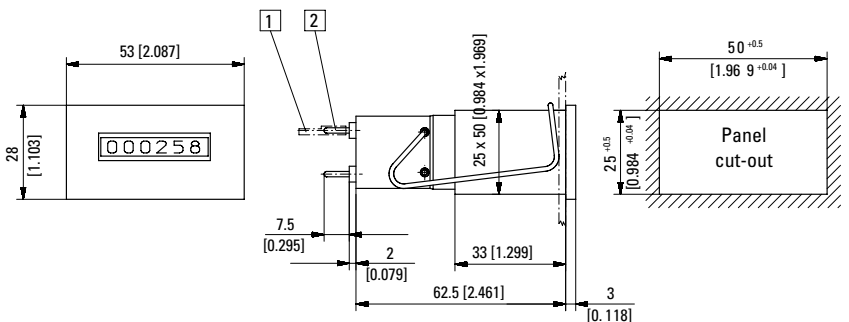

1 Push on connector \varnothing 1.5 [0.059], tinned 2 Round pin \varnothing 1.6 [0.063], tinned
Color of housing: grey (standard) – black, Art. no. 1.260.201.XXX

Type	Voltage	Display	Art. no.				Further stock types:
			12 V	24 V	115 V	230 V	
B 18.20	DC (10 Hz) / 0	8 digits, without reset	1.260.200.012	1.260.200.013 ¹⁾			1.260.201.013
	DC (25 Hz) / 1		1.260.200.032	1.260.200.033 ¹⁾			
	AC (18 Hz) / a			1.260.200.061	1.260.200.064	1.260.200.066 ¹⁾	

Dimensions in mm [inch]

1) Stock types.

Pulse counters, electromechanical

Standard counters **6 or 8 digits with/without reset (AC+DC)** **B 16 / B 18**

**Panel mount with front bezel size no. 3
and 2 mounting holes**
8 digits, without reset
Type B 18.30

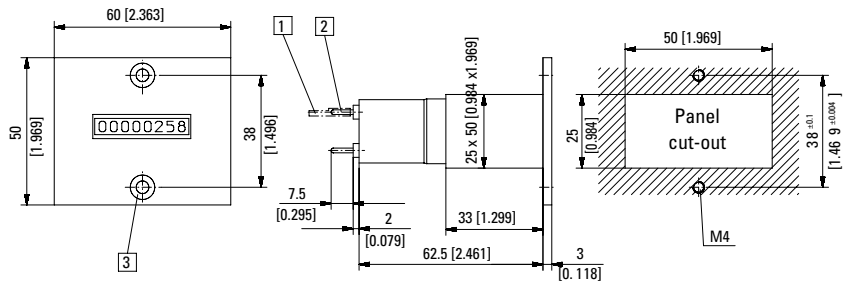

1 Push on connector \varnothing 1.5 [0.059], tinned 2 Round pin \varnothing 1.6 [0.063], tinned 3 Countersinking Am 4 DIN 74
Color of housing: grey (standard) – black, Art. no. 1.260.301.XXX

Type	Voltage	Display	Art. no.			
			12 V	24 V	115 V	230 V
B 18.30	DC (10 Hz) / 0	8 digits, without reset	1.260.300.012	1.260.300.013		
	DC (25 Hz) / 1		1.260.300.032	1.260.300.033		
	AC (18 Hz) / a			1.260.300.061	1.260.300.064	1.260.300.066

Mounting examples for optional accessories

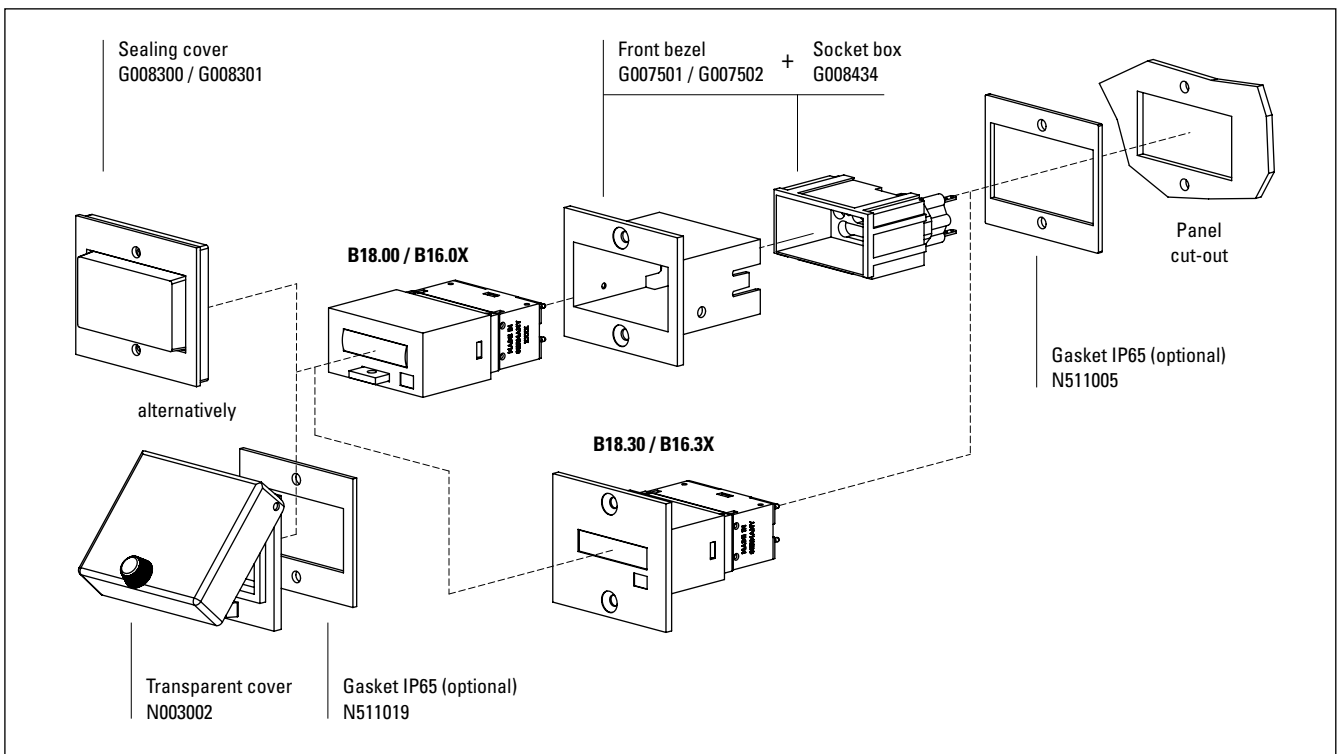

Dimensions in mm [inch]

Product overview
Basics
Pulse counters
Preset counters
Hour meters
Timers
Frequency displays
Tachometers
Position displays
Multifunction devices
Energy meters
Process devices
Temperature devices
Strain-gauge controllers
Accessories
Index

Pulse counters, electromechanical

Standard counters

4 or 6 digits with/without reset, electrical reset (AC+DC)

Mk 14 / Mk 16



The standard totalizers Mk 14 (with manual reset) and Mk 16 (with manual or manual and electrical reset) boast a robust construction.

They are ideal for use in harsh industrial environments.



Characteristics

- 6-digit totalizer without reset.
- 4- or 6-digit totalizer with manual, manual and electrical reset.
- Mk 16 has integrated electrical reset.

Benefits

- Very long service life (200 million pulses).

Applications

Piece counting, event counting, time and charge metering.

Type series

Description	reset	4 digits	6 digits	Order information
Panel mount with front bezel and 2 mounting holes	manual	Mk 14.11	Mk 16.11	<ul style="list-style-type: none"> • Art. no. • For special voltages, please give type, voltage and series e.g.: Mk 16.21, 48 V AC, type a
Panel mount for clip mounting	without	–	Mk 16.20	
	manual	Mk 14.21	Mk 16.21	
	manual and electrical	–	Mk 16.23	

Technical data	
Electrical connection	flat pin 0.8 x 2.8 mm [0.032 x 0.11"] with flat push on connector
Rated voltage	type 0 / 1 / a 12 / 24 / 48 / 60 / 115 / 230 V DC $\pm 10\%$ 24 / 48 / 60 / 115 / 230 V AC $\pm 10\%$
Housing	Makrolon, similar to RAL 7001
Height of figures	4 mm [0.16"]
Color of figures	white on black
Counting mechanism shaft	stainless steel
Mounting position	any
Operating life	approx. 200 x 10 ⁶ pulses
Protection	with reset IP40 (front side) without reset IP41 (front side)
Weight	reset manual Mk 14 – 85 g [3.00 oz] Mk 16 – 100 g [3.53 oz] reset electrical Mk 14 – 145 g [5.12 oz] Mk 16 – 140 g [4.94 oz]
Test voltage	2000 V ~ effective
Vibration resistance	3 g up to 10 Hz 6 g up to 15 Hz independent of position 10 g 20 - 300 Hz
EMC standards	EN 55011 class B EN 61000-6-2, EN 61000-6-3
Device safety	designed to protection class 2 application area EN 61010 part 1 pollution level 2

Options
Extended temperature range

Reset magnet	
Power consumption	DC approx. 9 W AC approx. 12 VA
Rated voltage	12 / 24 / 48 / 60 / 115 / 230 V DC $\pm 10\%$ 24 / 48 / 60 / 115 / 230 V AC $\pm 10\%$
Permissible residual ripple	max. 48 %
Minimum pulse time	0.25 sec, during 0.3 sec no count pulse is allowed
Cycle duration factor	Mk 16 15 %, max. 1.0 min Mk 14 10 %, max. 40 sec

Connection diagram

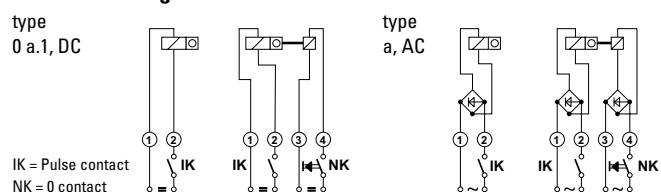

Pulse counters, electromechanical

Standard counters	4 or 6 digits with/without reset, electrical reset (AC+DC)	Mk 14 / Mk 18
--------------------------	---	----------------------

Type / Counting mechanism									
Voltage	Type	Pulse frequency max.	Pulse on time min.	Pulse interval min.	Pulse ratio	On-time	Power consump. approx.	Permi. residual ripple max.	Operating temp. (non-condensing)
V DC	0	10 Hz	64 ms	40 ms	3 : 2	100 %	1 W	48 %	-10°C ... +45°C [+14°F ... +113°F]
V DC	1	25 Hz	24 ms	16 ms	3 : 2	100 %	2 W	48 %	-10°C ... +45°C [+14°F ... +113°F]
V AC	a	18 Hz	22.2 ms	33.3 ms	2 : 3	100 %	2.9 VA	–	-10°C ... +45°C [+14°F ... +113°F]

Panel mount, front bezel with 2 mounting holes
4 digits, manual reset
Type Mk 14.11

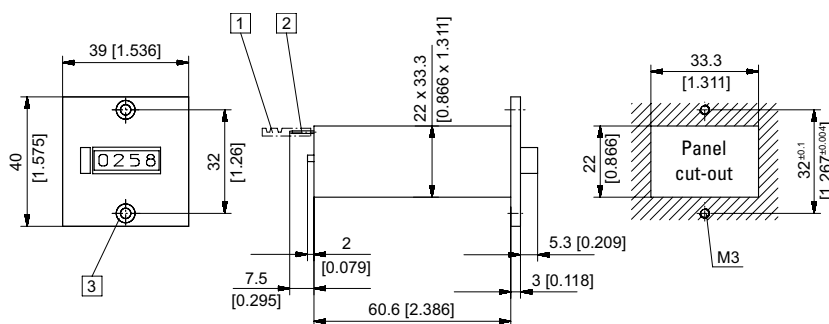

- 1 Flat push on connector 0.8 x 2.8 [0.032 x 0.11], tinned
 - 2 Flat pin 0.8 x 2.8 [0.032 x 0.11], tinned
 - 3 Countersinking Af3 DIN 74
- Color of housing black, Art. no. 1.310.111.XXX

Type	Voltage	Display	Art. no.			
			12 V	24 V	115 V	230 V
Mk 14.11	DC (10 Hz) / 0	4 digits, manual reset	1.310.110.012	1.310.110.013		
	DC (25 Hz) / 1		1.310.110.032	1.310.110.033		
	AC (18 Hz) / a		1.310.110.061	1.310.110.064	1.310.110.066	

Panel mount, for clip mounting
4 digits, manual reset
Type Mk 14.21

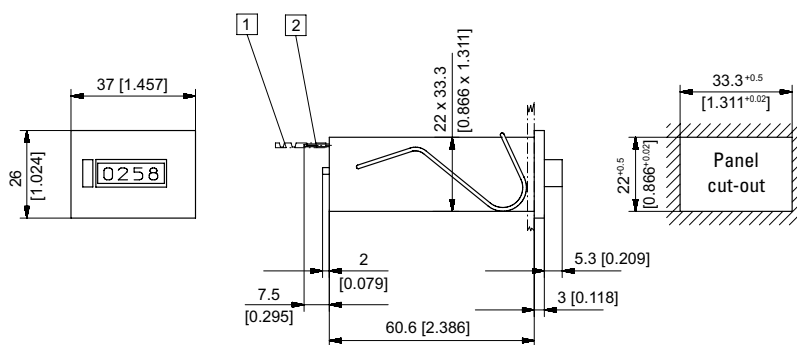

- 1 Flat push on connector 0.8 x 2.8 [0.032 x 0.11], tinned
 - 2 Flat pin 0.8 x 2.8 [0.032 x 0.11], tinned
- Color of housing black, Art. no. 1.310.211.XXX

Type	Voltage	Display	Art. no.			
			12 V	24 V	115 V	230 V
Mk 14.21	DC (10 Hz) / 0	4 digits, manual reset	1.310.210.012	1.310.210.013		
	DC (25 Hz) / 1		1.310.210.032	1.310.210.033		
	AC (18 Hz) / a		1.310.210.061	1.310.210.064	1.310.210.066	

Dimensions in mm [inch]

Product overview
Basics
Pulse counters
Preset counters
Hour meters
Timers
Frequency displays
Tachometers
Position displays
Multifunction devices
Energy meters
Process devices
Temperature devices
Strain-gauge controllers
Accessories
Index

Pulse counters, electromechanical

Standard counters

4 or 6 digits with/without reset, electrical reset (AC+DC)

Mk 14 / Mk 16

Panel mount, front bezel with 2 mounting holes

6 digits, manual reset

Type Mk 16.11

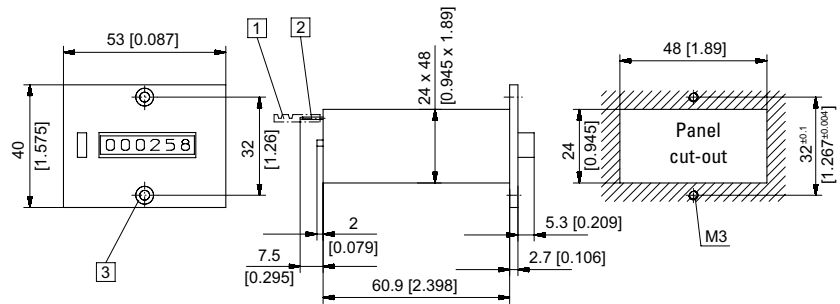
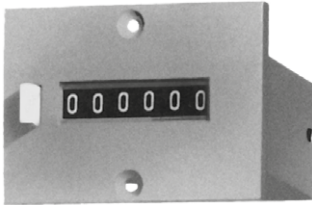

- 1 Flat push on connector 0.8 x 2.8 [0.032 x 0.11], tinned 2 Flat pin 0.8 x 2.8 [0.032 x 0.11], tinned
 3 Countersinking Af3 DIN 74 Color of housing black, Art. no. 1.340.111.XXX

Type	Voltage	Display	Art. no.			
			12 V	24 V	115 V	230 V
Mk 16.11	DC (10 Hz) / 0	6 digits,	1.340.110.012	1.340.110.013		
	DC (25 Hz) / 1	manual reset	1.340.110.032	1.340.110.033		
	AC (18 Hz) / a			1.340.110.061	1.340.110.064	1.340.110.066

Panel mount for clip mounting

6 digits, without reset

Type Mk 16.20

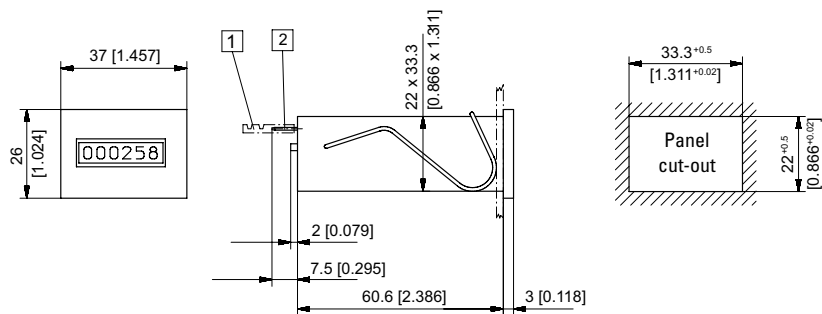

- 1 Flat push on connector 0.8 x 2.8 [0.032 x 0.11], tinned 2 Flat pin 0.8 x 2.8 [0.032 x 0.11], tinned
 Color of housing black, Art. no. 1.330.201.XXX

Type	Voltage	Display	Art. no.			
			12 V	24 V	115 V	230 V
Mk 16.20	DC (10 Hz) / 0	6 digits,	1.330.200.012	1.330.200.013		
	DC (25 Hz) / 1	without reset	1.330.200.032	1.330.200.033		
	AC (18 Hz) / a			1.330.200.061	1.330.200.064	1.330.200.066

Pulse counters, electromechanical

Standard counters **4 or 6 digits with/without reset, electrical reset (AC+DC)** **Mk 14 / Mk 16**

Panel mount for clip mounting
6 digits, manual reset

Type Mk 16.21

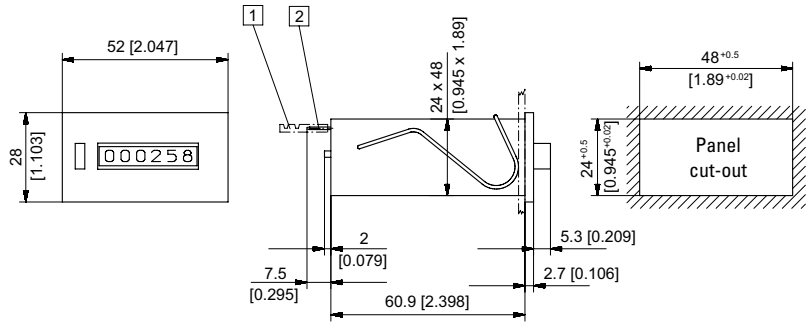

1 Flat push on connector 0.8 x 2.8 [0.032 x 0.11], tinned 2 Flat pin 0.8 x 2.8 [0.032 x 0.11], tinned
Color of housing black, Art. no. 1.340.21 1.XXX

Type	Voltage	Display	Art. no.			
			12 V	24 V	115 V	230 V
Mk 16.21	DC (10 Hz) / 0	6 digits,	1.340.210.012	1.340.210.013		
	DC (25 Hz) / 1	manual reset	1.340.210.032	1.340.210.033		
	AC (18 Hz) / a			1.340.210.061	1.340.210.064	1.340.210.066

Panel mount, for clip mounting
6 digits, manual and electrical reset

Type Mk 16.23

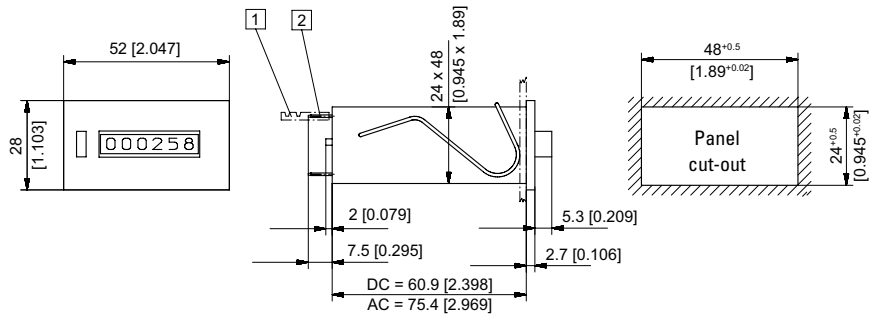

1 Flat push on connector 0.8 x 2.8 [0.032 x 0.11], tinned 2 Flat pin 0.8 x 2.8 [0.032 x 0.11], tinned
Color of housing black, Art. no. 1.340.23 1.XXX

Type	Voltage	Display	Art. no.			
			12 V	24 V	115 V	230 V
Mk 16.23	DC (10 Hz) / 0	6 digits, manual	1.340.230.012	1.340.230.013		
	DC (25 Hz) / 1	and electr. reset	1.340.230.032	1.340.230.033		
	AC (18 Hz) / a			1.340.230.061	1.340.230.064	1.340.230.066

Pulse counters, pneumatic

Pneumatic counters

4 digits with, 6 digits with/without, 8 digits without reset

PMk 14 / PMk 16 / PMk 18



The pneumatic totalizers **PMk 14**, **PMk 16** (with manual reset) and **PMk 18** (without reset) boast a robust construction.

They are ideal for use in harsh industrial environments, where the counters are directly driven by compressed air.

Characteristics

- Economical pneumatical totalizers.
- PMk 14 and PMk 16 with manual reset.
- PMk 18 without reset.
- Counting via armature system with membrane.

Benefits

- No leakage.
- Also available with quick connection system.

Applications

Pneumatically operated devices and equipment.

Type series

Description	reset	4 digits	6 digits	8 digits
Panel mount with front bezel and 2 mounting holes	without	–	–	PMk 18.10
	manual	PMk 14.11	PMk 16.11	–
Panel mount for clip mounting	without	–	–	PMk 18.20
	manual	PMk 14.21	PMk 16.21	–

Technical data

Pneumatic connections	M5 inner thread, 4 mm [0.16"] deep
Air purity	oil free or oil containing, the filter required must eliminate impurities > 40 µm
Mounting position	any
L-signal	1.5 ... 8 bar ±15 %
O-signal	≤ 0.15 bar
Max. safe pressure	9 bar (static)
Max. pulse frequency	at 1.5 bar 50 Hz at 2.5 bar 25 Hz at 6 bar 10 Hz at 8 bar 5 Hz depends on hose length
Pulse ratio	1:1 at max. pulse frequency, depending on the control
Max. Hose length (transmitter - counter, 1.5 bar)	at 50 Hz 0.3 m [11.81"] at 25 Hz 0.4 m [15.75"] at 10 Hz 0.5 m [19.67"]
Height of figures	4 mm [0.16"]
Color of figures	white on black
Connection volume	0.19 m³
Operating temperature	-10°C ... +60°C [+14°F ... +140°F] (non-condensing)
Protection	with reset IP40 (front side) without reset IP41 (front side)

Options

Connector for polyamide hose	ø 4 x ø 6 mm [0.16 x 0.24"] Art. no.: 3.XXX.XXX.063
Quick connection for tube outside diameter 4 mm	QSM-M5-4 N140620 Art. no.: 3.XXX.XXX.064

Pulse counters, pneumatic

Pneumatic counters **4 digits with, 6 digits with/without, 8 digits without reset** **PMk 14 / PMk 16 / PMk 18**

Panel mount with front bezel and 2 mounting holes
4 digits, manual reset
Type PMk 14.11

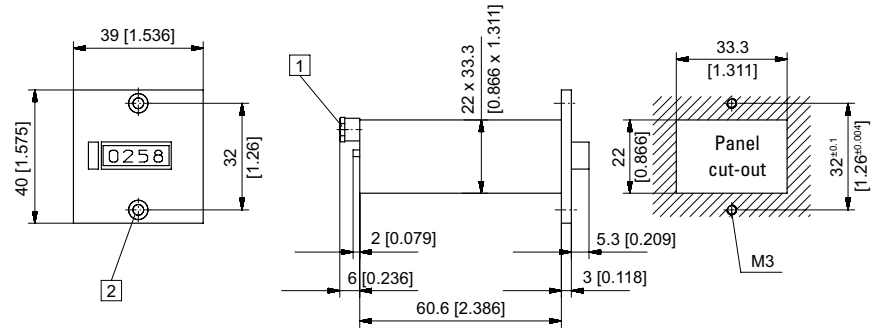
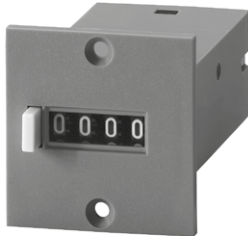

1) Inner thread M5, 4 [0.16] deep 2) Countersinking Af3 DIN 74

Type	Display	Color of housing / Art. no.	
		grey	black
PMk 14.11	4 digits, manual reset	3.802.110	3.802.111

Panel mount for clip mounting
4 digits, manual reset
Type PMk 14.21

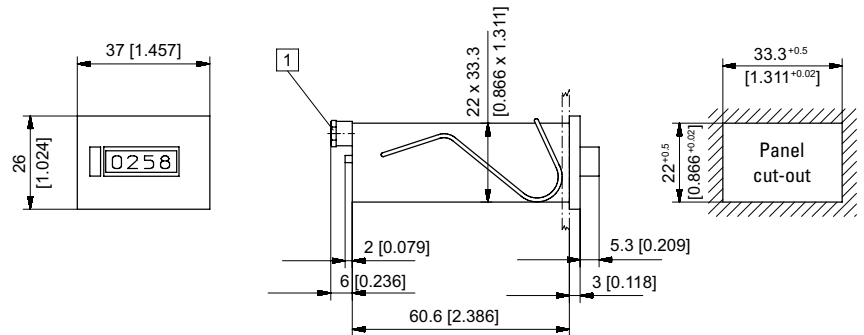

1) Inner thread M5, 4 [0.16] deep

Type	Display	Color of housing / Art. no.	
		grey	black
PMk 14.21	4 digits, manual reset	3.802.210	3.802.211

Panel mount with front bezel and 2 mounting holes
6 digits, manual reset
Type PMk 16.11

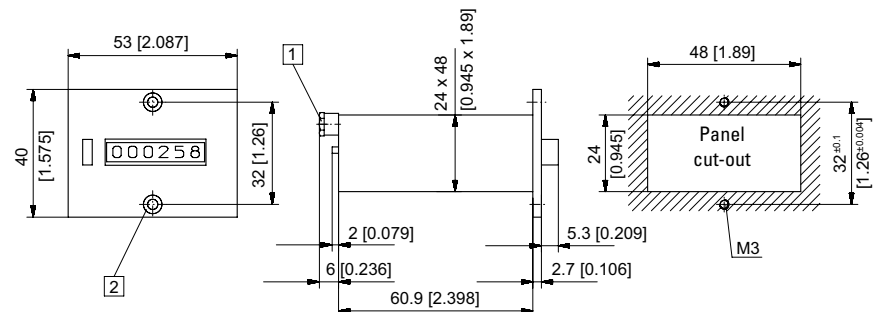

1) Inner thread M5, 4 [0.16] deep 2) Countersinking Af3 DIN 74

Type	Display	Color of housing / Art. no.	
		grey	black
PMk 16.11	6 digits, manual reset	3.804.110 ¹⁾	3.804.111

Dimensions in mm [inch]

1) Stock types.

Pulse counters, pneumatic

Pneumatic counters

4 digits with, 6 digits with/without, 8 digits without reset

PMk 14 / PMk 16 / PMk 18

Panel mount for clip mounting
6 digits, manual reset

Type PMk 16.21

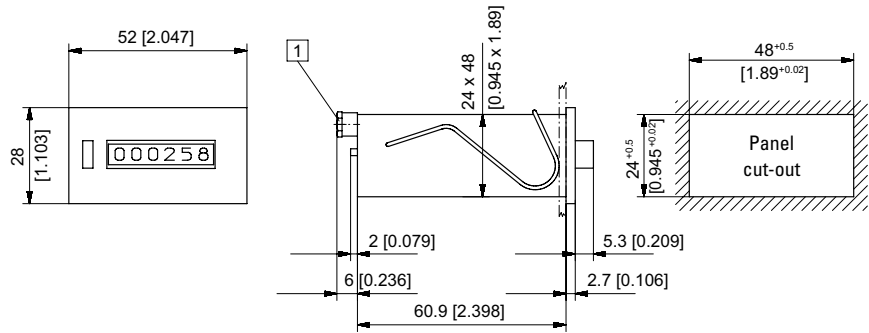

1) Inner thread M5, 4 [0.16] deep

Type	Display	Color of housing / Art. no.	
		grey	black
PMk 16.21	6 digits, manual reset	3.804.210	3.804.211

Panel mount with front bezel and 2 mounting holes
8 digits, without reset

Type PMk 18.10

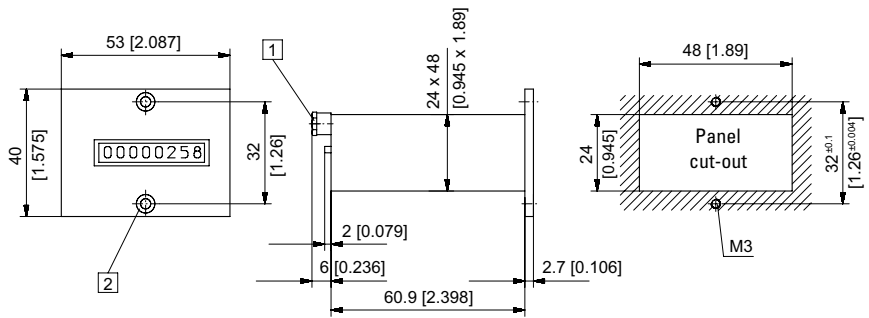

1) Inner thread M5, 4 [0.16] deep 2) Countersinking Af3 DIN 74

Type	Display	Color of housing / Art. no.	
		grey	black
PMk 18.10	8 digits, without reset	3.805.100	3.805.101

Panel mount for clip mounting
8 digits, without reset

Type PMk 18.20

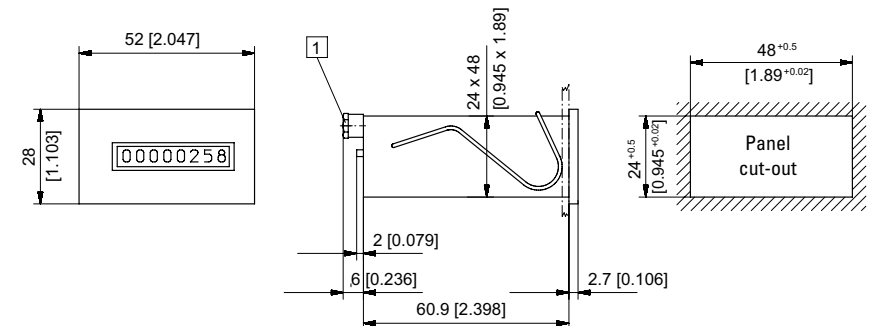

1) Inner thread M5, 4 [0.16] deep

Type	Display	Color of housing / Art. no.	
		grey	black
PMk 18.20	8 digits, without reset	3.805.200	3.805.201

	Product overview Basics
	Pulse counters
	Preset counters
	Hour meters Timers
	Frequency displays Tachometers
	Position displays
	Multifunction devices
	Energy meters
	Process devices
	Temperature devices
	Strain-gauge controllers
	Accessories Index



Product overview
Basics

Pulse counters

Preset counters

Hour meters
Timers

Frequency displays
Tachometers

Position displays

Multifunction
devices

Energy meters

Process devices

Temperature
devices

Strain-gauge
controllers

Accessories
Index

Preset counters

Preset counters, electronic		Type	Page
LCD preset counters	1 preset – pulse, time (battery)	901	120
	1 or 2 presets – pulse, time – 5 kHz (AC+DC)	Codix 907 / 908	124
	Multifunctional – pulse, frequency, time – 1 ... 6 presets (AC+DC)	Codix 923 / 924	127
Time preset counters with multicolor or LED look	Multifunctional – pulse, frequency, time – 1 ... 6 presets (AC+DC)	Codix 923 / 924	127
LCD touch preset counter 	Pulse, frequency, time (also reciprocal) – (AC+DC)	571T	247
LED preset counters	Multifunctional – pulse, frequency, time – 65 kHz, 2 presets (AC+DC)	Codix 560	134
	Dual preset counters with 4 switch outputs and analog output	572	139
LED position preset counter	SSI o. incremental input / 4 switch outputs + analog output	575	142
Preset counters, electromechanical		Type	Page
Standard counters	Adding, 5 digits (AC+DC)	BVa 15	145
	Subtracting, 2 or 3 digits (AC+DC)	MVs 13	150
	Subtracting, 6 digits (AC+DC)	MVs 16	154

Product overview
Basics

Pulse counters

ars
Preset
counters

Hour mete
Timers

Frequency displays
Tachometers

Position displays

Multifunction
devices

Energy meters

Process devices

Temperature
devices

Strain-gauge
controllers

Accessories
Index

LCD preset counters **1 preset – pulse, time (battery)** **901**



Type 901 is a simple battery-powered preset pulse counter/timer with 12 ... 250 V AC/DC count and reset inputs or with NPN input. The 6-digit, 2-line LCD display shows the current count value, the preset value, the relay state and the active time measurement.



Battery powered	Sensor power supply 12...250 V	Max. count frequency 30 Hz	Temperature range -20°...+65°C	High protection level IP65	DIN front bezel DIN 48 x 48	Multifunctional	Plug-in screw terminal	Menu-driven programming	Decade key entry	Relay output 1

Powerful

- Count and reset input electrically separated from the counter: input switching levels 12 ... 250 V AC/DC or NPN input signal.
- 2-line LCD display for count and preset. Displays the switching status of the output and the active time measurement.
- Data retention thanks to exchangeable lithium batteries, battery life approx. 8 years.
- Output: relay, programmable as normally open or normally closed.

Simple

- Easy to programme.
- Simple preset entry; one key per decade.
- Plug-in screw terminals.
- Replacement for electromechanical preset counters.
- No external power supply necessary.
- Clock function.

Order no.

Type of input	Order no.	Delivery specification
12 ... 250 V AC/DC	6.901.010.820 ¹⁾	- Counter 901 - 2 lithium batteries - 1 screw terminal - 1 spring clip - 1 operating instructions
NPN input	6.901.010.850 ¹⁾	- 1 front bezel for screw mounting, panel cut-out 50 x 50 mm [1.97 x 1.97"], T008860 - 1 front bezel for spring clip mount, panel cut-out 50 x 50 mm [1.97 x 1.97"], T008853 - 1 template for panel cut-out

1) Stock types.

Preset counters, electronic

LCD preset counters		1 preset – pulse, time (battery)	901
Accessories	Dimensions in mm [inch]		Order no.
Adapter front bezel, 72 x 72 [2.83 x 2.83]	for cut-out 68 x 68 [2.68 x 2.68] to cut-out 45 x 45 [1.77 x 1.77] (mating clip T009420 must be ordered separately)	black mating clip	T008177 T009420
Adapter front bezel, ø 72 [2.83]	for cut-out ø 60 [2.36] to cut-out 45 x 45 [1.77 x 1.77] with clip mounting for counters 48 x 48 [1.89 x 1.89]	black	N510226
Transparent cover, IP65	for cut-out 50 x 50 [1.97 x 1.97], with screw mounting for counters with cut-out 45 x 45 [1.77 x 1.77] and front bezel 48 x 48 [1.89 x 1.89]	lockable key lockable	G008143 G008153
Sealing cover type K2, IP65	suitable for front bezel 75 x 60 [2.95 x 2.36] with screw mounting	transparent/black	G008303
Mounting frame with cut-out 50 x 50 [2.36 x 2.36] via separate adapter also for 45 x 45 [1.77 x 1.77]	for snap-on mounting on 35 [1.38] top-hat DIN rail, for counters 48 x 48 [1.89 x 1.89], 53 x 53 [2.09 x 2.09] and 55 x 55 [2.17 x 2.17]	chromated	G300003
Gaskets	60 x 75 [2.36 x 2.95] for cut-out 50 x 50 [1.97 x 1.97] 58 x 58 [2.28 x 2.28] for cut-out 50 x 50 [1.97 x 1.97]		N511020 N511004
Replacement parts			Order no.
7-pin connector	1 ... 7, pitch 5.08		N100548

Suitable gaskets, other accessories and installation examples for optional accessories can be found in chapter Accessories or in the Accessories section under: www.kuebler.com/accessories.

Technical data

General technical data	
Display	2 line LCD display, 6 digits 999999; 7 or 4.5 mm [0.28 or 0.18"] high
Operating temperature	-20°C ... +65°C [-4°F ... +149°F] (non-condensing)
Storage temperature	-25°C ... +70°C [-13°F ... +158°F]
Altitude	up to 2000 m [6562']

Electrical characteristics	
Power supply	2 pcs user exchangeable lithium-batteries type 1/2 AA lithium 3.6 V
Data retention	min. 8 years at 5 x 10 ⁶ power operations of the output relay and an operating temperature of 25°C [+104°F]
EMC standards	EN 55011 class B EN 61000-6-2, EN 61000-6-3, EN 61326-1
Device safety	designed to protection class application area EN 61010-1, EN 61010-2-201 2 (front side) pollution level 2
UL approval	file E128604

Mechanical characteristics	
Protection	IP65 (front side)
Weight	approx. 80 g

Inputs	
Inputs	reset, count and key lock inputs
Polarity of the inputs (for reset and count/start input)	12 ... 250 V AC/DC bidirectional optocoupler input NPN NPN input activated by transistor or contact
Keyboard lock input	connected to +3 V DC (terminal 1)
Min. pulse duration of the inputs	reset input 50 ms keyboard lock input 15 ms
Switching levels of the inputs	12 ... 250 V AC/DC LOW: < 1 V AC/DC HIGH: 12 ... 250 V AC/DC NPN LOW: 0 ... 0.8 V DC HIGH: 2.5 ... 5 V DC
Input frequency	max. 30 Hz
Input resistance	110 kΩ

Outputs	
Output	bistable relay with potential free contact (programmable as normally closed or normally opened contact)
Max. switching voltage	250 V AC / 30 V DC
Max. switching current	2 A
Max. switching capacity	60 VA / 30 W
Output response time	< 20 ms, max. 4 Hz
Insulation coordination	basic insulation

Preset counters, electronic

LCD preset counters

1 preset – pulse, time (battery)

901

Programming

The counter is programmed using the keys on the front. The user is guided by plain text on the display.

The following modes are programmable:

1. Function: pulse preset counter or preset timer
2. Count mode (adding or subtracting)
3. Output: permanent signal or timed signal in case of automatic repetition (loop)
4. Output (normally open or normally closed)
5. Timed signal duration (Delay) in case of automatic repetition 0.1 ... 99.9 seconds
6. Decimal point up to max. 5 decimal places (pulse counter) or up to max. 2 decimal places (preset timer)
7. Time range for the preset timer: seconds minutes, hours

Function of the output

- Adding:
Relay is active, when actual value \geq preset
- Subtracting:
Relay is active, when actual value ≤ 0

In case of automatic repetition, the output signal is a timed signal programmable in 100 ms steps from 0.1 to 99.9 seconds.

A colon is displayed on the lower display line when the relay is activated.

An indicator flashes at one-second intervals when timing is active.

Operating the counter

- Setting or resetting:
Press the red SET button or apply a pulse to the reset input to set the counter to zero in the adding mode or to the preset in the subtracting mode.
- Presetting:
The preset value is indicated on the lower row of digits. To set it, use the 6 presetting buttons assigned to each decade. The set value will be accepted with the next set or reset operation.
- Overflow and underflow:
In the adding mode the overflow is 999 999 to 0; in the subtracting mode it is 0 to 999 999. The output signal remains unaffected.
- Lo-bat-indicator:
When the battery charge is too low, Lo-bat appears in the lower display. This flashes on a two second cycle. When lo-bat is indicated, the battery should be changed as soon as possible. If the charge goes on decreasing, the device switches to (noFunc) "no function" mode and must be reprogrammed.
- Changing the battery:
The unit retains the programmed values if the batteries are replaced within 2 minutes. Otherwise, the device must be re-parameterized.
- Counting:
By means of positive pulses (12 ... 250 VAC) or by a NPN input pulse. Time counting remains active as long as the counter input is active (preset timer).

Terminal assignment 12 ... 250 V AC/DC

Pin	Inputs / outputs
1	+3 V DC for terminal 2
2	Keyboard lock-input
3	Relay contact
4	Relay contact
5	AC/DC optocoupler count input
6	AC/DC optocoupler reset input
7	Common AC/DC input for terminal 6 and 5

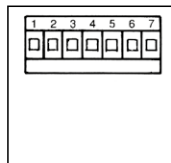

Example of connection 12 ... 250 V AC/DC

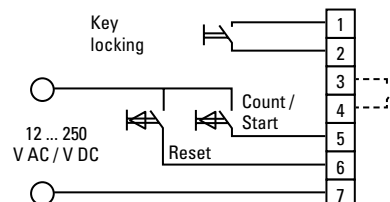

Terminal assignment NPN

Pin	Inputs / outputs
1	+3 V DC for terminal 2
2	Keyboard lock-input
3	Relay contact
4	Relay contact
5	NPN count/start input
6	NPN reset input
7	Common AC/DC input for terminal 6 and 5

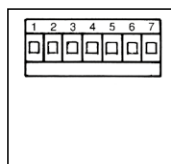

Example of connection NPN

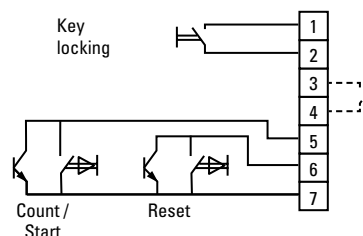

Preset counters, electronic

LCD preset counters	1 preset – pulse, time (battery)	901
----------------------------	---	------------

Dimensions

Dimensions in mm [inch]

Panel cut-out 45 x 45 [1.77 x 1.77]

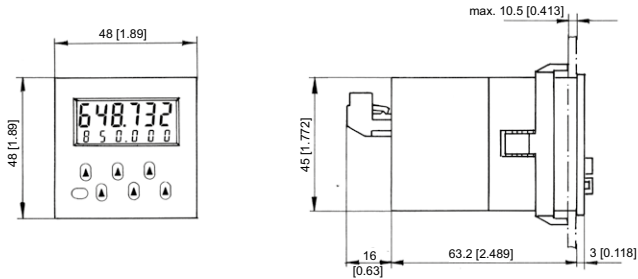

With front bezel 55 x 55 [2.17 x 2.17], panel cut-out 50 x 50 [1.97 x 1.97]

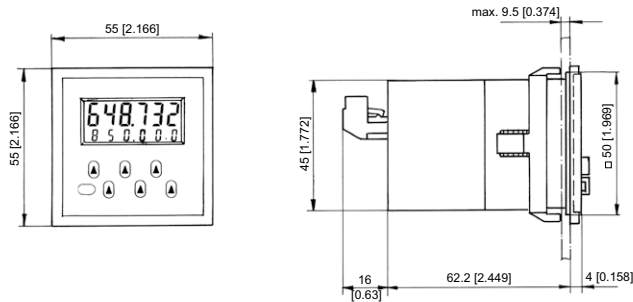

With front bezel 60 x 75 [2.36 x 2.95], panel cut-out 50 x 50 [1.97 x 1.97]

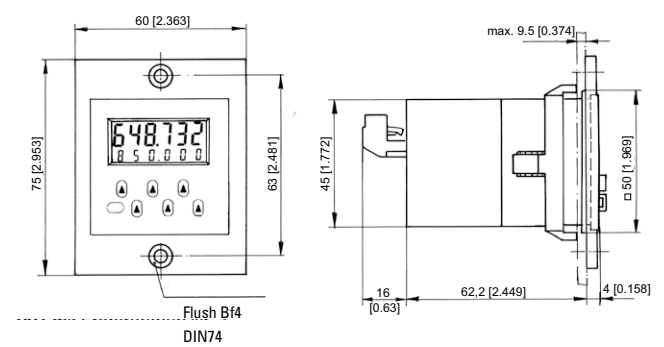

Product overview
Basics

Pulse counters

Preset counters

Hour meters
Timers

Frequency displays
Tachometers

Position displays

Multifunction
devices

Energy meters

Process devices

Temperature
devices

Strain-gauge
controllers

Accessories
Index

Preset counters, electronic

LCD preset counters

1 or 2 presets – pulse, time – 5 kHz (AC+DC)

Codix 907 / 908



The pulse and time preset counters Codix 907 and 908 offer all important counter functions with an unbeatable price/performance ratio.

The counters offer easy, user-friendly installation thanks to their minimal installation depth and plug-in screw terminals; the 2-line LCD display is available with optional backlighting, making it even easier to read with just a quick glance.



 DC 11 ... 30 V Power supply	 AC 115/230V Power supply	 - 10° + 50° Temperature range	 000000 DIN 48 x 48	 P R O G Menu-driven programming	 IP65 High protection level	 max. 5 kHz Count frequency	 Plug-in screw terminal	 1 or 2 Presets 907: 1 / 908: 2	 Multifunctional
 2x6 LCD LCD display	 Multicolor display								

Powerful

- For pulse, time and position.
- Adding or subtracting.
- Automatic reset when preset is reached, or by key-press or electrically.
- Codix 907: 1 preset / Codix 908: 2 presets.
- 2 x 6-digit display and preset annunciators from -999999 to +999999.
- Display with or without backlighting, 2-color.

Simple

- Plug-in screw terminal.
- Simple menu-driven programming.
- Decade keypad, for each digit one key.
- DC or AC powered.
- Minimum installation depth.
- High protection level (IP65) with integrated front bezel gasket.
- With preset annunciators.

Order code

6.90 X . 0 1 0 X . X A 0

a Number of presets

- 7 = 1 preset
- 8 = 2 presets

b Outputs

- 0 = relays

c LCD version

- 0 = no backlighting
- 1 = green backlighting
- 4 = 2-color, negative red / green backlighting

d Power supply

- 0 = 230 V AC
- 1 = 115 V AC
- 3 = 11 ... 30 V DC

e Input trigger level

- A = 4 ... 30 V DC level

Delivery specification

- Preset counter
- Mounting clip
- 8 pin screw terminal
- 7 pin screw terminal
- Operating instructions

Stock types

- 6.907.0100.3A0
- 6.908.0100.3A0
- 6.907.0100.0A0
- 6.908.0100.0A0
- 6.908.0101.0A0

Product overview
Basics

Pulse counters

Preset counters

Hour meters
Timers

Frequency displays
Tachometers

Position displays

Multifunction
devices

Energy meters

Process devices

Temperature
devices

Strain-gauge
controllers

Accessories
Index

Preset counters, electronic

LCD preset counters		1 or 2 presets – pulse, time – 5 kHz (AC+DC)		Codix 907 / 908	
Accessories		Dimensions in mm [inch]		Order no.	
Adapter front bezel, 55 x 55 [2.17 x 2.17]	for cut-out 50 x 50 [1.97 x 1.97] to cut-out 45 x 45 [1.77 x 1.77] with clip mounting for counters 48 x 48 [1.89 x 1.89]	black		T008853	
	Gasket 58 x 58 [2.28 x 2.28], for cut-out 50.2 x 50.2 [1.98 x 1.98]			N511004	
Adapter front bezel, 60 x 75 [2.36 x 2.95]	for cut-out 50 x 50 [1.97 x 1.97] to cut-out 45 x 45 [1.77 x 1.77] with screw mounting for counters 48 x 48 [1.89 x 1.89]	black		T008860	
	Gasket 60 x 75 [2.36 x 2.95] for cut-out 50 x 50 [1.97 x 1.97]			N511020	
Adapter front bezel, 72 x 72 [2.83 x 2.83]	for cut-out 68 x 68 [2.68 x 2.68] to cut-out 45 x 45 [1.77 x 1.77] (Mating clip T009420 must be ordered separately)	black mating clip		T008177	
				T009420	
Sealing cover type K2, IP65	suitable for front bezel 75 x 60 [2.95 x 2.36] with screw mounting	transparent/black		G008303	
Transparent cover, IP65	for cut-out 50 x 50 [1.97 x 1.97], with screw mounting for counters with cut-out 45 x 45 [1.77 x 1.77] and front bezel 48 x 48 [1.89 x 1.89]	lockable key lockable		G008143	
				G008153	
Mounting frame with cut-out 50 x 50 [2.36 x 2.36] via separate adapter also for 45 x 45 [1.77 x 1.77]	for snap-on mounting on 35 [1.38] top-hat DIN rail, for counters 48 x 48 [1.89 x 1.89], 53 x 53 [2.09 x 2.09] and 55 x 55 [2.17 x 2.17]	chromated		G300003	
Replacement parts				Order no.	
8-pin connector	1 ... 8, pitch 3.81			N100498	
7-pin connector	9 ... 15 (for 923 / 924), pitch 5.08			N100548u002	

Suitable gaskets, other accessories and installation examples for optional accessories can be found in chapter Accessories or in the Accessories section under: www.kuebler.com/accessories.

Technical data

General technical data		Electrical characteristics	
Display	2 line 2 x 6 digits LCD display upper line 9 mm [0.35"], lower line 7 mm [0.28"], special sign 2 mm high [0.079"] standard positive green with optional backlighting 2-color upper line: negative, red backlighting lower line: negative, green backlighting	Sensor power supply	AC 115/230 V, ±10 %, 50/60 Hz, max. 6.5 VA DC 11 ... 30 V, max. 4 W
Operating temperature	-10°C ... +50°C [+14°F ... +122°F] (non-condensing)	External fuse protection	230 V AC T 0.1 A 115 V AC T 0.125 A 11 ... 30 V DC T 0.2 A
Storage temperature	-25°C ... +75°C [-13°F ... +167°F]	Data retention	> 10 years, EEPROM
Humidity at +40°C [+104°F]	RH 93 % (non-condensing)	Input modes	pulse counter cnt.dir, up.dn, quad timer FrErun, InpA.InpB., InpB.InpB.
Altitude	up to 2000 m [6562']	Sensor power supply	AC supply 24 V DC -40/+15 %, 50 mA at 230 V AC, 40 mA at 115 V AC DC supply max. 50 mA external power supply is connected through
Mechanical characteristics		EMC standards	EN 55011 class B, EN 61000-6-2, EN 61000-6-3, EN 61326-1
Protection	IP65 (front side)	Device safety	designed to EN 61010 part 1 protection class 2 application area pollution level 2
Weight	AC version approx. 250 g [8.82 oz] DC version approx. 150 g [5.29 oz]		

Preset counters, electronic

LCD preset counters	1 or 2 presets – pulse, time – 5 kHz (AC+DC)	Codix 907 / 908
----------------------------	---	------------------------

Inputs	
Count inputs	A and B (timer: A = Gate)
Polarity of the inputs	programmable for all inputs in common, NPN/PNP
Input resistance	10 kΩ
Count frequency	max. 5 kHz (details see manual) can be damped to 30 Hz (mechanical contacts)
Control / Reset input	Lock, Reset
Min pulse duration of signal and control inputs	statical / 1 ms
Switching levels with AC/DC supply	4 ... 30 V DC: low 0 ... 2 V DC high 3.5 ... 30 V DC
Pulse shape	variable, Schmitt-Trigger characteristics

Outputs	
Switching voltage	max. 250 V AC / 110 V DC
Switching current	max. 3 A AC/DC min. 30 mA DC
Switching capacity	max. 750 VA / 90 W
Output 1	Mech. service life (switching cycles) 2 x 10 ⁷ N° of switching cycles at 3 A / 250 V AC 1 x 10 ⁵ N° of switching cycles at 3 A / 30 V DC 1 x 10 ⁵ Relay with closing contact, progr. normal closed or normal open.
Output 2	Mech. service life (switching cycles) 20 x 10 ⁶ N° of switching cycles at 3 A / 250 V AC 5 x 10 ⁴ N° of switching cycles at 3 A / 30 V DC 5 x 10 ⁴ Relay with changeover contact
Reaction time of the outputs	pulse counter < 15 ms timer < 10 ms

Terminal assignment

Pin	Signal and control inputs
1	Sennsor power supply
2	GND (0 V DC)
3	INP A (Signal input A)
4	INP B (Signal input B)
5	RESET (Reset input)
6	LOCK (Key locking input)
7	n. c.
8	n. c.

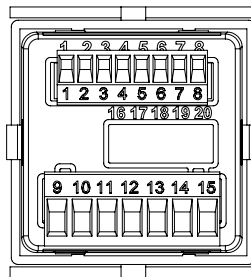

Pin	Version with relays
9	Relay contact C.
10	Relay contact N.O.
11	Relay contact C.
12	Relay contact N.O.
13	Relay contact N.C.
14	AC: 115/230 V AC N~ DC: 11 ... 30 V DC
15	AC: 115/230 V AC L~ DC: GND (0 V DC)

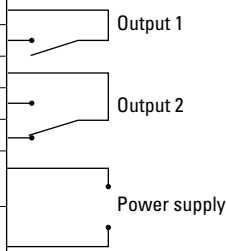

Dimensions

Dimensions in mm [inch]

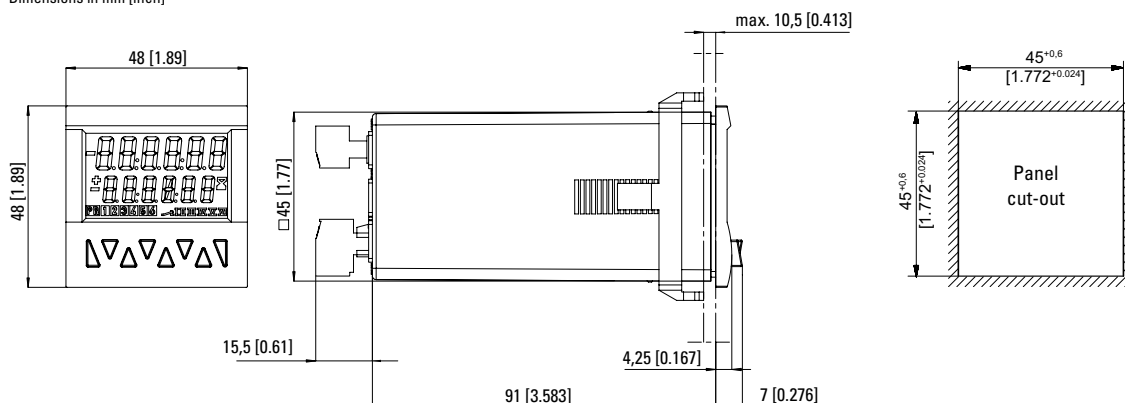

Product overview Basics
Pulse counters
Preset counters
Hour meters Timers
Frequency displays Tachometers
Position displays
Multifunction devices
Energy meters
Process devices
Temperature devices
Strain-gauge controllers
Accessories Index

Preset counters, electronic

LCD preset counters **Multifunctional – pulse, frequency, time – 1...6 presets (AC+DC)** **Codix 923 / 924**



The multifunction preset counters Codix 923 / 924 can be used universally. These preset pulse counters, tachometers or preset timers with up to 6 presets can solve a wide variety of control and monitoring tasks in every application.

With their two-line display in 4 different versions the counters are very easy to read and simple to programme using the clearly laid-out decade keys. Complex control tasks can be carried out using a batch count or total count function.



Product overview
Basics
Pulse counters
Preset counters
Hour meters
Timers
Frequency displays
Tachometers
Position displays
Multifunction devices
Energy meters
Process devices
Temperature devices
Strain-gauge controllers
Accessories
Index

DC 10 ... 30 V Power supply	AC 100 ... 240 V Temperature range	-20° + 65° Temperature range	000000 DIN 48 x 48 DIN front bezel	t/Hz HRA Frequency meter HRA	Prog Menu-driven programming	IP65 High protection level	max. 65 kHz Count frequency	Plug-in screw terminal Plug-in screw terminal	1 ... 6 Presets	Multifunctional Multifunctional
2x6 LCD LCD display	Multicolor display Multicolor display	POSITION Position display	Batch Batch counter	Σ Totalizer						

Multifunctional

- Counter, tachometer and timer in one device.
- Can be used a preset counter, batch counter, totalizer or position display with tracking preset.
- Presets: 923: 1, 924: 2, 924-4: 4, 924-6: 6.
- Relay or optocoupler outputs.
- Many different count modes for pulse inputs, time and frequency.
- Scalable input using multiplication and division factor
- Set value.
- Averaging, start delay (tachometer).
- Step or tracking presets (eliminate the need for reprogramming of the pre-signal).
- Multi-range power supply.

Fast and user-friendly

- Direct input of the presets via the front keys or via the Teach-In input.
- Fast installation thanks to plug-in screw terminals.
- Max. count frequency 65 kHz.
- Simultaneous display of the actual and of the preset value, or of the actual value and of the batch / totalizing counter.
- Annunciators for the displayed preset and for the output status.
- 3 predefined parameter settings.
- Direct entry into the programming.
- Minimal installation depth.
- 4-stage RESET modes.
- 3-stage key lockout.
- Multicolor display for improved differentiation.

Order code

6.92 X . 0 1 X X . X X X
a b c d e f

a Number of presets

- 3 = 1 preset
- 4 = 2, 4 or 6 presets

b Output

- 0 = relays
- 1 = optocouplers (only a = 4)²⁾

c LCD options

- 0 = no backlighting
- 1 = green backlighting¹⁾
- 2 = LED look, negative, red backlighting¹⁾
- 3 = multicolor, negative red/green backlighting

d Power supply

- 0 = 100 ... 240 V AC, ±10 %
- 2 = 24 V AC, ±10 %
- 3 = 10 ... 30 V DC

e Input trigger level

- 0 = standard level (HTL)
- A = 4 ... 30 V DC level¹⁾

f Version

- 0 = standard 923/924
- B = 6 optocoupler outputs²⁾
- 924-6 (only b = 1)
- C = 4 relay outputs²⁾
- 924-4 (only b = 0)

Delivery specification

- Preset counter
- Mounting clip
- 8 pin screw terminal
- 7 pin screw terminal
- Operating instructions

Stock types

6.923.0100.000	6.924.0100.000
6.923.0100.300	6.924.0100.300
6.923.0101.000	6.924.0101.000
6.923.0101.300	6.924.0101.300
6.923.0102.000	6.924.0102.000
6.923.0102.300	6.924.0102.300
6.923.0103.000	6.924.0103.000
6.923.0103.300	6.924.0103.300
	6.924.0100.00C
	6.924.0100.30C
	6.924.0113.00B
	6.924.0113.30B

Additional inputs, outputs or interface types on request

1) 24 V AC on request

2) Not possible in 24 V AC.

Preset counters, electronic

LCD preset counters		Multifunctional – pulse, frequency, time – 1...6 presets (AC+DC)		Codix 923 / 924
Accessories	Dimensions in mm [inch]		Order no.	
Adapter front bezel, 55 x 55 [2.17 x 2.17]	for cut-out 50 x 50 [1.97 x 1.97] to cut-out 45 x 45 [1.77 x 1.77] with clip mounting for counters 48 x 48 [1.89 x 1.89]	black	T008853	
	Gasket 58 x 58 [2.28 x 2.28], for cut-out 50.2 x 50.2 [1.98 x 1.98]		N511004	
Adapter front bezel, 60 x 75 [2.36 x 2.95]	for cut-out 50 x 50 [1.97 x 1.97] to cut-out 45 x 45 [1.77 x 1.77] with screw mounting for counters 48 x 48 [1.89 x 1.89]	black	T008860	
	gasket 60 x 75 [2.36 x 2.95] for cut-out 50 x 50 [1.97 x 1.97]		N511020	
Adapter front bezel, 72 x 72 mm [2.83 x 2.83]	for cut-out 68 x 68 [2.68 x 2.68] to cut-out 45 x 45 [1.77 x 1.77] (mating clip T009420 must be ordered separately)	black	T008177	
	mating clip		T009420	
Sealing cover type K2, IP65	suitable for front bezel 75 x 60 [2.95 x 2.36] with screw mounting	transparent/black	G008303	
Transparent cover, IP65	for cut-out 50 x 50 [1.97 x 1.97], with screw mounting for counters with cut-out 45 x 45 [1.77 x 1.77] and front bezel 48 x 48 [1.89 x 1.89]	lockable key lockable	G008143 G008153	
Mounting frame with cut-out 50 x 50 [2.36 x 2.36] via separate adapter also for 45 x 45 [1.77 x 1.77]	for snap-on mounting on 35 [1.38] top-hat DIN rail, for counters 48 x 48 m [1.89 x 1.89], 53 x 53 [2.09 x 2.09] and 55 x 55 [2.17 x 2.17]	chromated	G300003	
Replacement parts			Order no.	
8-pin connector	1 ... 8, pitch 3.81		N100498	
7-pin connector	9 ... 15 (for 923 / 924), pitch 5.08		N100548u002	
	9 ... 15 (for 924-4 / 924-6), pitch 5.08		N100400u002	
5-pin connector	16 ... 20, pitch 3.81		N100399u002	

Suitable gaskets, other accessories and installation examples for optional accessories can be found in chapter Accessories or in the Accessories section under: www.kuebler.com/accessories.

Technical data	
General technical data	
Display	2 line 2 x 6 digits LCD display standard positive green with optional backlighting LED look negative red backlighting multicolor upper line negative, red backlighting lower line negative, red or green backlighting (programmable)
Operating temperature	-20°C ... +65°C [-4°F ... +149°F] (non-condensing)
Storage temperature	-25°C ... +75°C [-13°F ... +167°F]
Humidity at +40°C [+104°F]	RH 93 % (non-condensing)
Altitude	up to 2000 m [6562']
Mechanical characteristics	
Protection	IP65 (front side)
Weight	approx. 125 g [4.41 oz]
Electrical characteristics	
Sensor power supply	AC (50/60 Hz) 100 ... 240 V AC, ±10 %, max. 9.5 VA 24 V AC ±10 %, max. 6 VA DC 10 ... 30 V, max. 5.5 W
External fuse protection	100 ... 240 V AC T 0.1 A 24 V AC T 0.315 A 10 ... 30 V DC T 0.2 A
Data retention	> 10 years, EEPROM
Input modes	pulse counters: Count direction (cnt.dir), Difference (up.dn), Addition A+B (up.up), phase discriminator x1, x2, x4 (quad, quad x2, quad x4), Ratio (A/B), Ratio in % ((A-B)/A x 100%) frequency meter: A, A-B, A+B quad, A/B, (A-B)/A x 100 % timer: 4 Start modes: FrErun, Auto, InpA.InpB., InpB.InpB.
Sensor power supply	AC supply 24 V DC ±15 %, 80 mA DC supply max. 80 mA, external power supply is connected through
EMC standards	EN55011 class B, EN 61000-6-2, EN 61000-6-3
Device safety	designed to EN61010 part 1 protection class 2 application area pollution level 2
UL approval	file E128604

Preset counters, electronic

LCD preset counters Multifunctional – pulse, frequency, time – 1...6 presets (AC+DC) Codix 923 / 924

Inputs													
Count inputs	A and B												
Polarity of the inputs	programmable for all inputs in common NPN/PNP												
Input resistance	5 kΩ												
Count frequency	pulse counters max. 55 kHz tachometers max. 65 kHz (details see manual) can be damped to 30 Hz (mechanical contacts)												
Control / Reset input	MPI, Lock, Gate, Reset												
Min pulse duration of signal and control inputs	10 ms / 1 ms												
Switching levels with AC supply	<table border="0"> <tr> <td>HTL level:</td> <td>LOW</td> <td>0 ... 4 V DC</td> </tr> <tr> <td></td> <td>HIGH</td> <td>12 ... 30 V DC</td> </tr> <tr> <td>4 ... 30 V DC:</td> <td>LOW</td> <td>0 ... 2 V DC</td> </tr> <tr> <td></td> <td>HIGH</td> <td>3.5 ... 30 V DC</td> </tr> </table>	HTL level:	LOW	0 ... 4 V DC		HIGH	12 ... 30 V DC	4 ... 30 V DC:	LOW	0 ... 2 V DC		HIGH	3.5 ... 30 V DC
HTL level:	LOW	0 ... 4 V DC											
	HIGH	12 ... 30 V DC											
4 ... 30 V DC:	LOW	0 ... 2 V DC											
	HIGH	3.5 ... 30 V DC											
Switching levels with DC supply	<table border="0"> <tr> <td>HTL level:</td> <td>LOW</td> <td>0 ... 0.2 x U_B</td> </tr> <tr> <td></td> <td>HIGH</td> <td>0.6 x U_B ... 30 V DC</td> </tr> <tr> <td>4 ... 30 V DC:</td> <td>LOW</td> <td>0 ... 2 V DC</td> </tr> <tr> <td></td> <td>HIGH</td> <td>3.5 ... 30 V DC</td> </tr> </table>	HTL level:	LOW	0 ... 0.2 x U _B		HIGH	0.6 x U _B ... 30 V DC	4 ... 30 V DC:	LOW	0 ... 2 V DC		HIGH	3.5 ... 30 V DC
HTL level:	LOW	0 ... 0.2 x U _B											
	HIGH	0.6 x U _B ... 30 V DC											
4 ... 30 V DC:	LOW	0 ... 2 V DC											
	HIGH	3.5 ... 30 V DC											
Pulse shape	variable, Schmitt-Trigger characteristics												

Outputs					
Outputs relay version (1 changeover contact with 923)					
Switching voltage	max. 250 V AC / 110 V DC				
Switching current	max. 3 A AC/DC min. 30 mA DC				
Switching capacity	max. 750 VA / 90 W				
Output 1 (Relay closing contact, programmable as normally open (NO) or normally closed (NC))					
Mech. service life (switching cycles)	2 x 10 ⁷				
N° of switching cycles at 3 A / 250 V AC	1 x 10 ⁵				
N° of switching cycles at 3 A / 30 V DC	1 x 10 ⁵				
Output 2 (Relay with changeover contact)					
Mech. service life (switching cycles)	2 x 10 ⁷				
N° of switching cycles at 3 A / 250 V AC	5 x 10 ⁴				
N° of switching cycles at 3 A / 30 V DC	5 x 10 ⁴				
Outputs optocoupler version					
Output 1 and 2 (npn optocoupler) switching power					
U _{CESAT} at IC = 10 mA	30 V DC / 10 mA				
U _{CESAT} at IC = 5 mA	max. 2.0 V				
	max. 0.4 V				
Reaction time of the outputs (pulse / time)	<table border="0"> <tr> <td>relay</td> <td>approx. 13 ms</td> </tr> <tr> <td>optocoupler</td> <td>approx. 1 ms</td> </tr> </table> Details see instruction manual	relay	approx. 13 ms	optocoupler	approx. 1 ms
relay	approx. 13 ms				
optocoupler	approx. 1 ms				
Response time of the frequency meter	100/600 ms details see instruction manual				

Codix 924-4 and 924-6

The preset counters 924-4 and 924-6 vary from the standard counters 923 and 924 as follows:

- Relay version: 924-4, 4 presets, 2 additional relays
- Optocoupler version: 924-6: 6 presets, 4 additional optocoupler outputs
- No tracking presets
- Presets 1 and 4 affect the batch or total counter
- Presets 2, 3, 5 and 6 (Type: 924-6) or presets 2 and 3 (Type 924-4) affect the main counter
- Preset 2 is the main preset; it triggers the automatic reset
- Preset 2 is likewise the main preset for all further counting modes (the other presets are pre-signals)

Additional technical data Codix 924-4	
Output 3	
Relay with closing contact (programmable as normally closed NC or normally open NO)	
Switching voltage	max. 125 V AC / 110 V DC
Switching current	max. 1 A AC / 1 A DC min. 1 mA AC/DC
Switching capacity	max. 62.5 VA / 30 W
Mech. service life (switching cycles)	5 x 10 ⁷
N° of switching cycles at 0.5 A / 125 V AC	1 x 10 ⁵
N° of switching cycles at 1 A / 30 V DC	1 x 10 ⁵
Output 4	
Relay with changeover contact	
Switching voltage	max. 125 V AC / 110 V DC
Switching current	max. 1 A AC / 1 A DC min. 1 mA AC/DC
Switching capacity	max. 62.5 VA / 30 W
Mech. service life (switching cycles)	5 x 10 ⁷
N° of switching cycles at 1 A / 110 V AC	1x10 ⁵
N° of switching cycles at 1 A / 30 V DC	1x10 ⁵
Reaction time of the outputs, Relay	< 7 ms (only impulse and time counter)
Max. count frequency	50 kHz
Operating temperature	-20°C ... +55°C [-4°F ... +131°F]

Additional technical data Codix 924-6	
Output 1 ... 6	
NPN optocouplers	
Switching capacity	30 V DC / 10 mA
U _{CESAT} at IC = 10 mA	max. 2.0 V
U _{CESAT} at IC = 5 mA	max. 0.4 V
output 3, 4, 5 and 6 with common emitter	
Reaction time of the outputs, optocouplers (only impulse and time counter)	
Add/Sub/	< 1 ms
with auto repeat	< 1 ms
A/B; (A-B)/A	< 23 ms
Max. count frequency	50 kHz

Preset counters, electronic

LCD preset counters

Multifunctional – pulse, frequency, time – 1...6 presets (AC+DC)

Codix 923 / 924

Terminal assignment

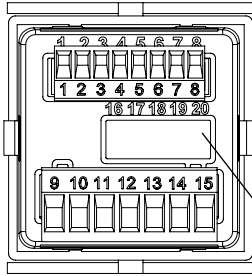

Pin	Signal and control inputs
1	Sensor power supply AC: 24 V DC / 80 mA DC: U_B interconnected
2	GND (0 V DC)
3	INP A (Signal input A)
4	INP B (Signal input B)
5	RESET (Reset input)
6	LOCK (Key locking input)
7	GATE (Gate input)
8	MPI (User input)

Pin	Version with relays/optocouplers
9	Relay contact C. / Kollektor
10	Relay contact N.O. / Emitter
11	Relay contact C. / Emitter
12	Relay contact N.O. / not assigned
13	Relay contact N.C. / Collector
14	AC: 24 V AC, 100 ... 240 VAC, $\pm 10\%$ N~ DC: 10 ... 30 V DC
15	AC: 24 V AC, 100 ... 240 VAC, $\pm 10\%$ L~ DC: GND (0 VDC)

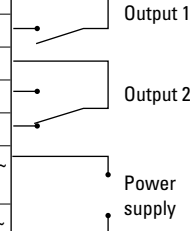

Pin	Additional connections 924-4
16	Relay contact N.C.4 output 4
17	Relay contact C.4 output 4
18	Relay contact N.O.4 output 4
19	Relay contact N.O.3 output 3
20	Relay contact C.3 output 3

Pin	Additional connections 924-6
16	Common-Emitter output 3 to 6
17	Collector 6 output 6
18	Collector 5 output 5
19	Collector 4 output 4
20	Collector 3 output 3

Dimensions

Dimensions in mm [inch]

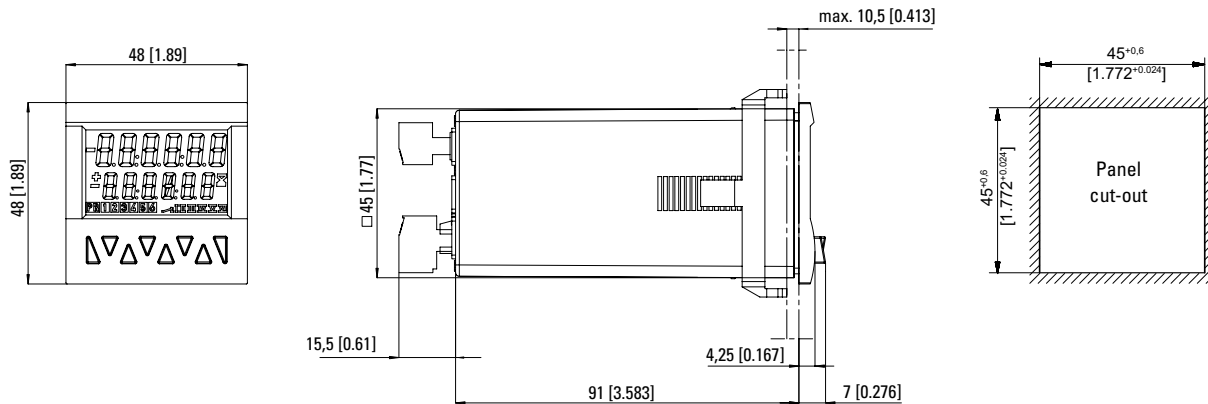

Product overview
Basics

Pulse counters

Preset counters

Hour meters
Timers

Frequency displays
Tachometers

Position displays

Multifunction
devices

Energy meters

Process devices

Temperature
devices

Strain-gauge
controllers

Accessories
Index

Preset counters, electronic

LCD preset counters **Multifunctional – pulse, frequency, time – 1...6 presets (AC+DC)** **Codix 923 / 924**

Product overview
Basics
Pulse counters
Preset counters
Hour meters
Timers
Frequency displays
Tachometers
Position displays
Multifunction devices
Energy meters
Process devices
Temperature devices
Strain-gauge controllers
Accessories
Index

Pulse counter

Functions / count modes:

- Count with direction mode
- Difference mode
- Quadrature mode quad/quad2/quad4
- Add, Sub, automatic reset
- 2-input adding mode A+B
- Ratio measurement A/B
- Percentage difference measurement $(A-B)/A \times 100 \%$
- Batch counting
- Totalizer (overall total)
- Multiplication and division factor (up to 99.9999)
- Set value
- Step or tracking preset

Application examples

CountDir + Add

Roller shutter door with automatic shut-off

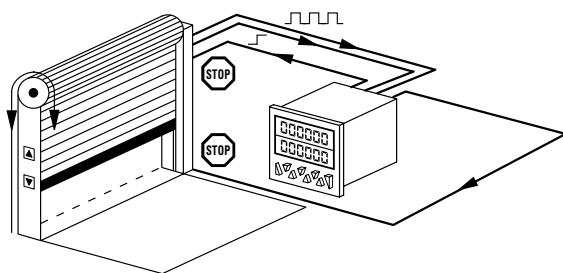

Quad + Add

Running direction and position on milling machines, Limit switch monitoring

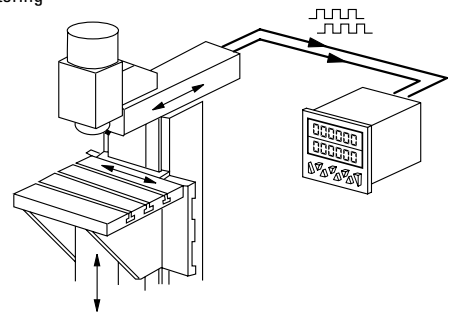

UpDown + Add

Automatic subtraction of faulty or reject parts from the total piece count

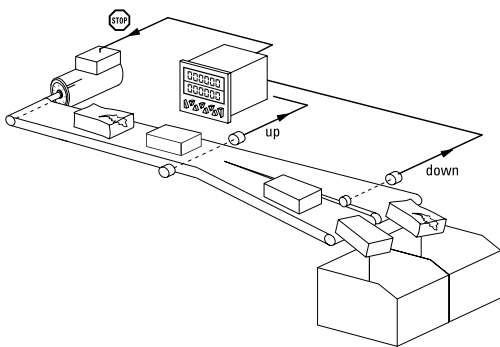

CountDir + Batch

Logging of piece numbers and packing units plus control of replenishment of packing cartons

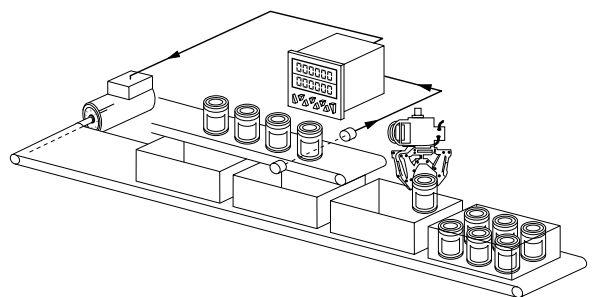

UpUp + Add

Adding up of two parallel or staggered production lines

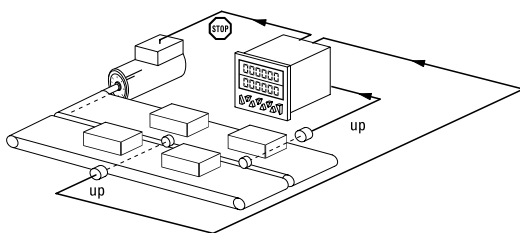

Quad + Add tot

Cut-to-length with overall total count and control of the machine

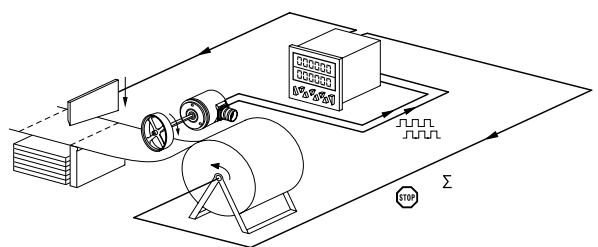

LCD preset counters

Multifunctional – pulse, frequency, time – 1...6 presets (AC+DC)

Codix 923 / 924

Frequency meter (tachometer)

Functions / count modes:

- A
- A - B
- A + B
- A / B
- $(A - B) / A \times 100\%$ (percentage display)
- Quad (phase discriminator with recognition of direction)
- Averaging
- Start delay
- 2nd tacho input
- Gate input
- Multiplication and division factor (up to 99.9999)

Application examples

A - B

Synchro monitoring and control of two conveyor belts

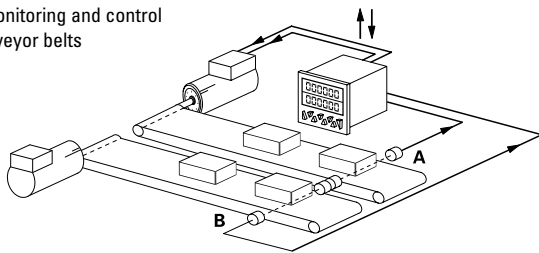

Quad

Speed regulation with indication of direction

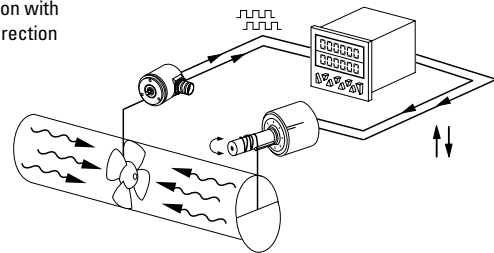

A/B

Ratio measurement

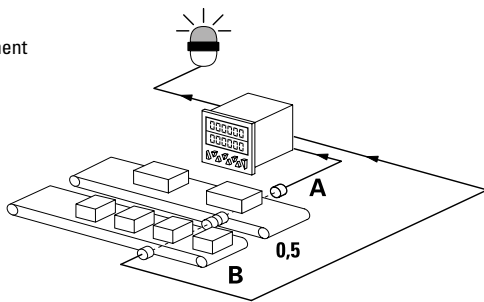

(A-B)/A [%]

Ratio measurement, e.g. for speed alignment

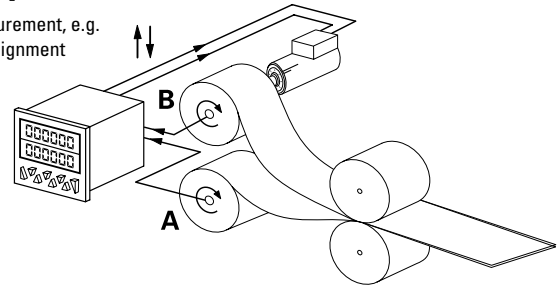

Time and Hours-run meter (timer)

Functions / count modes:

- FrErUn (control via gate input)
- Auto (start via reset, stop at preset)
- InpB.InpB (start with first edge at InpB., stop with second edge InpB.)
- InpA. InpB (start with InpA., stop with InpB.)
- Totalizer (overall total)
- Batch counting
- Set value
- Step or tracking preset

Application examples

InpB. InpB

Interval measurement

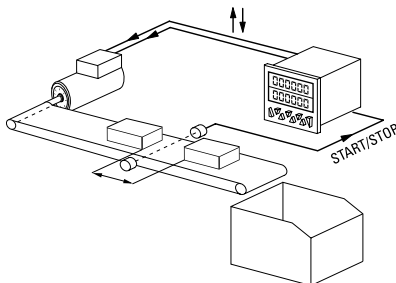

FrErUn

Measurement of overall time from switching on the conveyor belt till switching off

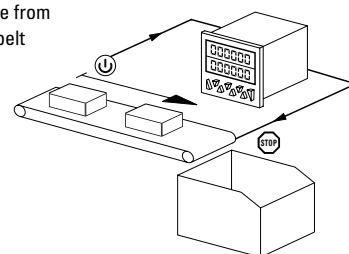

InpA. InpB

Run-time measurement

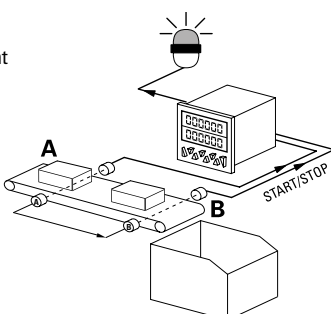

Auto

Time-controlled production line

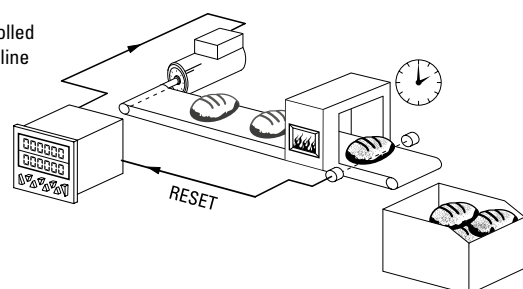

Preset counters, electronic

LCD preset counters	Multifunctional – pulse, frequency, time – 1...6 presets (AC+DC)	Codix 923 / 924
----------------------------	---	------------------------

Expandable hardware

Expandable on request via modules:

- 4 additional inputs
- Or 4 additional optocoupler outputs
- Or 2 additional relay outputs
- Or RS232/485 communications interfaces

Application examples

- Limit switch monitoring
- Special functions/PLC function
- Initiation of fixed program sequences
- Control of several processes
- Special protocols
- Print commands for logging

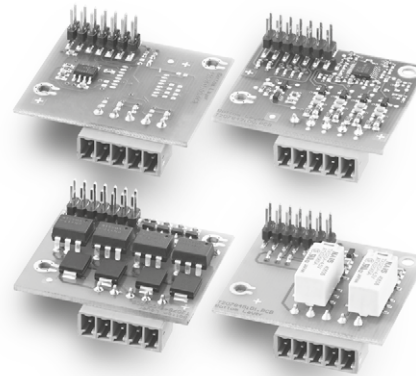

Customizable software

Individual customization of software to your application.

For example:

- Separate inputs for total counter and preset counter
- Separate scaling of input A and B
- Programmable measuring period for the tachometer
- Measurement of rotary speeds based on time
- Processing time, measurement of time based on frequency
- With the Multicolor version, the display color changes when reaching the preset, or blinking display with all versions



Product overview
Basics

Pulse counters

Preset counters

Hour meters
Timers

Frequency displays
Tachometers

Position displays

Multifunction
devices

Energy meters

Process devices

Temperature
devices

Strain-gauge
controllers

Accessories
Index

LED preset counters

Multifunctional – pulse, frequency, time – 65 kHz, 2 presets (AC+DC)

Codix 560



With its automatic help texts, clearly and legibly displayed on 14 LED segments, the Codix 560 preset counter takes the user effortlessly through the programming. The large user-friendly front keys can be operated even when wearing gloves.

The 14 mm high LED display ensures easy reading even from a long distance and in poor lighting conditions.

Now available also with RS232/RS485 interface and MODBUS and CR/LF protocol



DC 10 ... 30V Power supply	AC 100 ... 240V Power supply	-20° + 65° Temperature range	000000 DIN 96 x 48	PROG Menu-driven programming	IP65 High protection level	max. 65 kHz High count frequency	Hz Multifunctional	t/Hz HRA Frequency display with HRA	POSITION Position display	A..Z* LEDs 14 segment LED	
Batch Batch counter	Σ Total counter	RS 232 485 Optional interface									

Multifunctional

- Counter, tachometer, timer and position display in one device.
- Can be used as preset counter, batch counter or total counter.
- 2 relays (change-over).
- Many different count modes.
- Scalable display.
- Set value, step or tracking preset.
- Multi-range power supply for AC or DC.
- Readable or configurable via RS232/485 interface via MODBUS or CR/LF protocol.
- Allows direct connection of a large display or printer.

User-friendly

- Automatic help texts, displayed in German and English.
- 14-segment LED for improved text representation.
- Status display of the presets.
- 3 predefined parameters.
- Tracking presets eliminate the need for reprogramming of the pre-signal.
- Minimum installation depth.
- 4-stage RESET modes.
- 3-stage keypad locking.
- Suitable for installation in mosaic systems.

Order code

6.560 . 010 . XXX
a b c

a Power supply

0 = 100 ... 240 V AC, ±10 %¹⁾
3 = 10 ... 30 V DC¹⁾

b Input trigger levels

0 = Standard level (HTL)¹⁾
A = 4...30 V DC level

c Interface (optional)

0 = None¹⁾
5 = RS232 (MODBUS or CR/LF)
7 = RS485 (MODBUS or CR/LF)

Delivery specification

• Preset counter
• Mounting clip
• Instruction manual

Accessories

Dimensions in mm [inch]

Order no.

Mounting frame

with cut-out 92 x 45 [3.62 x 1.77]

for snap-on mounting on 35 [1.38] top-hat DIN rail,
for counters 96 x 48 [3.78 x 1.89]

grey

G300005

Suitable gaskets as well as further accessories can be found in the accessories section or in the accessories area of our website at: www.kuebler.com/accessories.

1) Stock types

Product overview
Basics

Pulse counters

Preset counters

Hour meters
Timers

Frequency displays
Tachometers

Position displays

Multifunction
devices

Energy meters

Process devices

Temperature
devices

Strain-gauge
controllers

Accessories
Index

Preset counters, electronic

LED preset counters Multifunctional – pulse, frequency, time – 65 kHz, 2 presets (AC+DC) Codix 560

Technical data

General technical data	
Display	6-digit red 14 segment LED display, 14 mm [0.55] high
Operating temperature	-20°C ... +65°C [-4°F ... +149°F] (non-condensing)
Storage temperature	-25°C ... +75°C [-13°F ... +167°F]
Relative humidity at +40°C [+104°F]	RH 93 % (non-condensing)
Altitude	up to 2000 m [6562']

Electrical characteristics	
Power supply	AC 100 ... 240 V AC, ±10 % max. 11 VA, 50/60 Hz DC 10 ... 30 V, max. 5.5 W
External fuse protection	230 V AC T 0.1 A 10 ... 30 V DC T 0.25 A
Data retention	> 10 years, EEPROM
Response time of the frequency meter	100 / 600 ms (details s. instruction manual)
Input modes	<p>pulse counters count direction (cnt.dir), difference (up.dn), addition A+B (up.up), phase discriminator x1, x2, x4 (quad, quad x2, quad x4), ratio (A/B), ratio in % ((A-B)/A x 100 %)</p> <p>frequency meter A, A-B, A+B quad, A/B, (A-B)/A x 100 %</p> <p>timer 4 start modes: FrErun, Auto, InpA.InpB., InpB.InpB.</p>
Sensor power supply	AC supply 24 V DC ±15 %, 80 mA DC supply max. 80 mA, external power supply is connected through
EMC standards	EN 55011 class B, EN 61000-6-2, EN 61000-6-3
Device safety	designed to protection class 2 application area EN 61010 part 1 2 pollution level 2
UL approval	file E128604

Mechanical characteristics	
Protection	IP65 (from the front)
Weight	approx. 180 g [6.35 oz]

Inputs	
Count inputs	A and B
Polarity of the inputs	programmable for all inputs in common, NPN/PNP
Input resistance	5 kΩ
Count frequency	<p>pulse counters max. 55 kHz</p> <p>tachometers max. 65 kHz</p> <p>can be damped to 30 Hz (mechanical contacts) (details s. instruction manual)</p>
Control / Reset input	MPI 1 and MPI 2, Lock, Gate, Reset
Min pulse duration of the inputs	10 ms / 1 ms
Switching levels with AC supply	<p>HTL-level: LOW: 0 ... 4 V DC HIGH: 12 ... 30 V DC</p> <p>4 ... 30 V DC: LOW: 0 ... 2 V DC HIGH: 3.5 ... 30 V DC</p>
Switching levels with DC supply	<p>HTL-level: LOW: 0 ... 0.2 x U_B HIGH: 0.6 x U_B ... 30 V DC</p> <p>4 ... 30 V DC: LOW: 0 ... 2 V DC HIGH: 3.5 ... 30 V DC</p>
Pulse shape	variable, Schmitt-Trigger characteristics

Outputs	
Switching voltage	max. 250 V AC / 150 V DC
Switching current	max. 3 A AC / DC min. 30 mA DC
Switching capacity	max. 750 VA / 90 W
Output 1 + 2	<p>mech. service life (switching cycles) 2 x 10⁷</p> <p>N° of switching cycles at 3 A / 250 V AC 5 x 10⁴</p> <p>N° of switching cycles at 3 A / 30 V DC 5 x 10⁴</p> <p>relay with changeover contact</p>
Reaction time of the outputs (pulse / time)	13 ms (details s. instruction manual)

Optional interface MODBUS and CR/LF	
Count frequency	max. 45 kHz (details s. instruction manual)
Interface	RS232, RS485
Baud rate	9600
Device address	1 ... 99, programmable

Terminal assignment

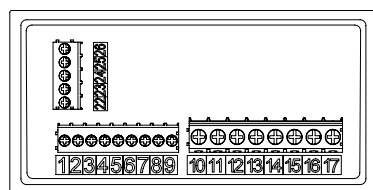

Pin	RS232 (optional)	Pin	RS485 (optional)
22	GND	22	-
23	RXD	23	DO
24	TXD	24	DI
25	-	25	-
26	-	26	-

Pin	Signal and control inputs
1	INP A (Signal input A)
2	INP B (Signal input B)
3	RESET (Reset input)
4	LOCK (Keypad lock)
5	GATE (Gate input)
6	MPI 1 (User input 1)
7	MPI 2 (User input 2)
8	Sensor power supply AC: 24 V DC/80 mA DC: U _B connected through
9	Shared connection for signal and control inputs GND (0 VDC)

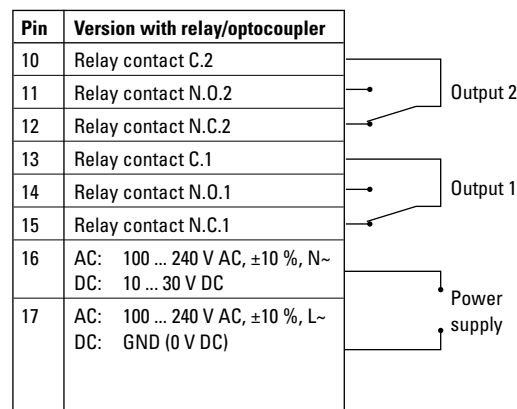

Preset counters, electronic

LED preset counters

Multifunctional – pulse, frequency, time – 65 kHz, 2 presets (AC+DC)

Codix 560

Pulse counter

Functions / count modes

- Count with direction mode
- Difference mode
- Quadrature mode quad / quad2 / quad4
- Add, Sub, automatic reset
- 2-input adding mode A+B
- Ratio measurement A/B
- Multi-range power supply for AC or DC
- Percentage difference measurement (A-B)/A x 100 %
- Batch counting
- Totalizer (Overall total)
- Multiplication and division factor (up to 99.9999)
- Set value
- Step or tracking preset

Application examples

CountDir + Add

Roller shutter door with automatic shut-off

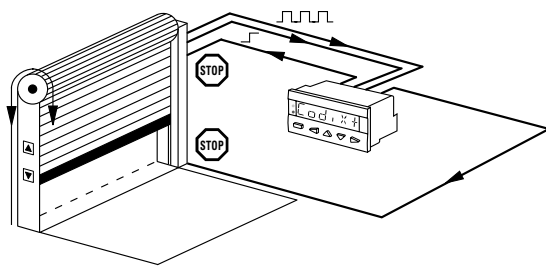

Quad + Add

Running direction and position on milling machines, Limit switch monitoring

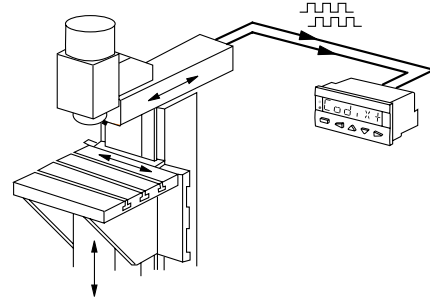

UpDown + Add

Automatic subtraction of faulty or reject parts from the total piece count

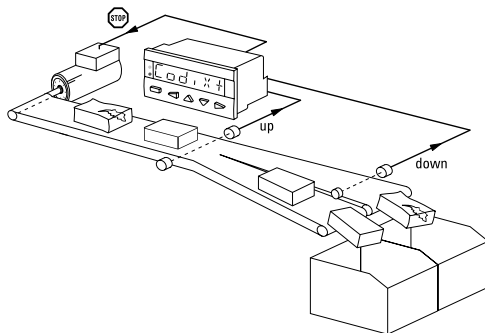

CountDir + Batch

Logging of piece numbers and packing units plus control of replenishment of packing cartons

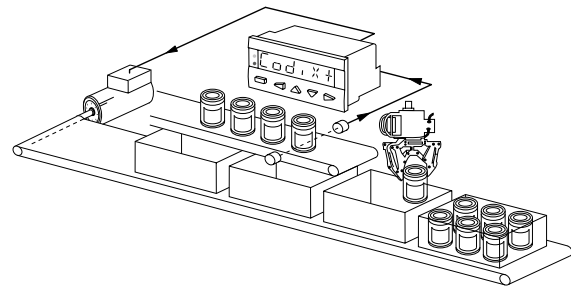

UpUp + Add

Adding up of two parallel or staggered production lines

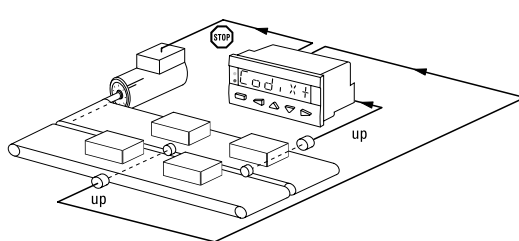

Quad + Add tot

Cut-to-length with overall total count and control of the machine

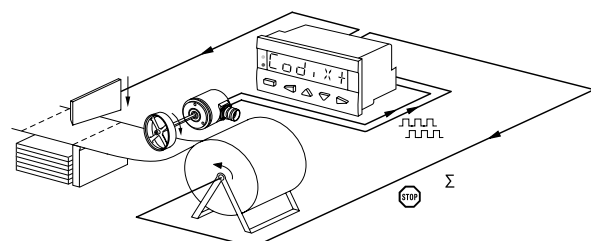

Product overview
Basics

Pulse counters

Preset counters

Hour meters
Timers

Frequency displays
Tachometers

Position displays

Multifunction
devices

Energy meters

Process devices

Temperature
devices

Strain-gauge
controllers

Accessories
Index

Preset counters, electronic

LED preset counters **Multifunctional – pulse, frequency, time – 65 kHz, 2 presets (AC+DC)** **Codix 560**

Product overview
Basics

Pulse counters

Preset counters

Hour meters
Timers

Frequency displays
Tachometers

Position displays

Multifunction
devices

Energy meters

Process devices

Temperature
devices

Strain-gauge
controllers

Accessories
Index

Frequency meter (tachometer)

Functions / count modes

- A
- A – B
- A + B
- A / B
- $(A - B) / A \times 100\%$ (percentage display)
- Quad (phase discriminator with recognition of direction)
- Averaging
- Start delay
- 2nd tachometer input
- Gate input
- Multiplication and division factor (up to 99.9999)

Application examples

A – B

Synchro monitoring and control of two conveyor belts

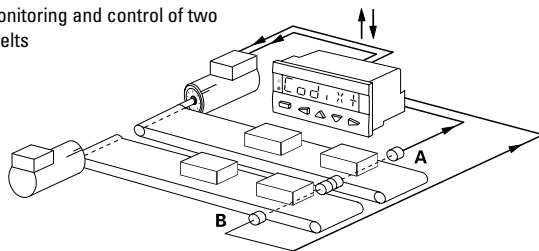

Quad

Speed regulation with indication of direction

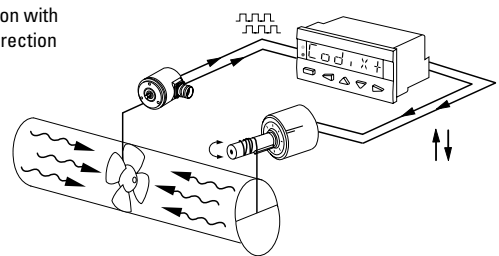

A/B

Ratio measurement

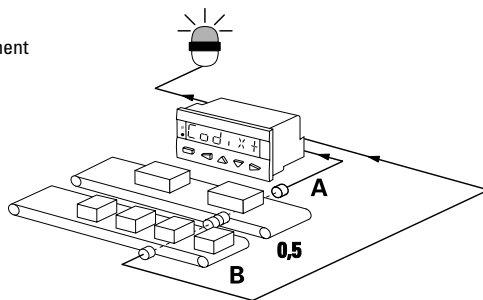

$(A-B)/A$ [%]

Ratio measurement, e.g. for speed alignment

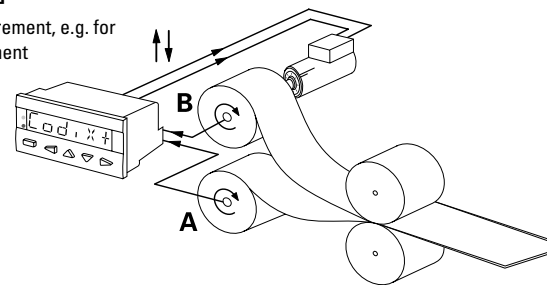

Time and hours-run meter (timer)

Functions / count modes

- FrErun (control via gate input)
- Auto (start via reset, stop at preset)
- InpB.InpB (start with first edge at InpB., stop with second edge InpB.)
- InpA. InpB (start with InpA., stop with InpB.)
- Totalizer (overall total)
- Batch counting
- Set value
- Step or tracking preset

Application examples

InpB. InpB

Interval measurement

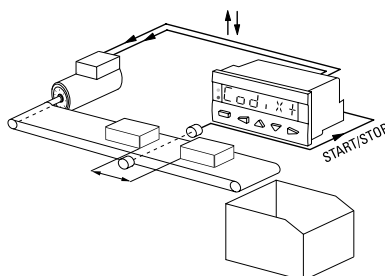

FrErun

Measurement of overall time from switching on the conveyor belt till switching off

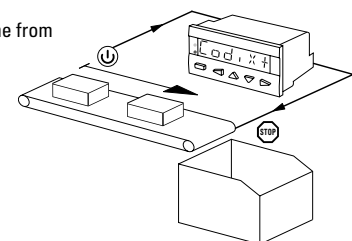

InpA. InpB

Run-time measurement

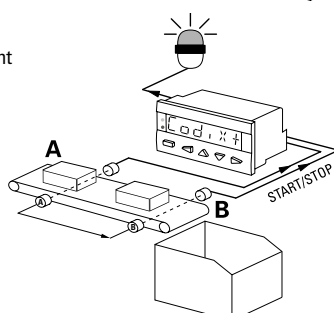

Auto

Time-controlled production line

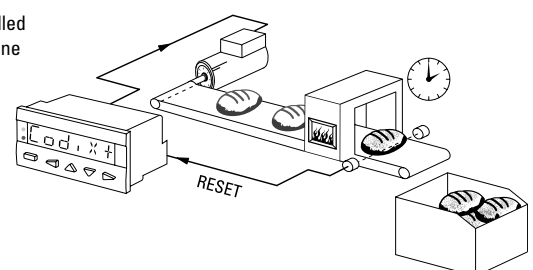

Preset counters, electronic

LED preset counters

Multifunctional – pulse, frequency, time – 65 kHz, 2 presets (AC+DC)

Codix 560

RS232 / RS485 interface (optional)

For connecting the counter to a PC, a PLC, a large display or a printer – for reading-out data or configuring the device.

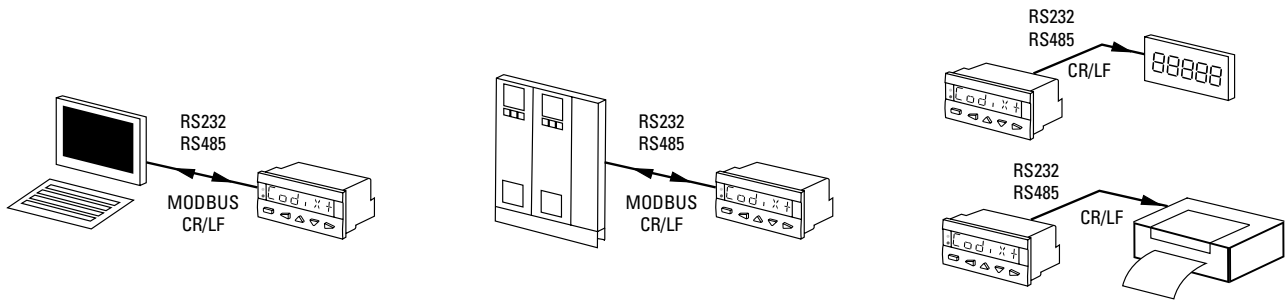

Dimensions

Dimensions in mm [inch]

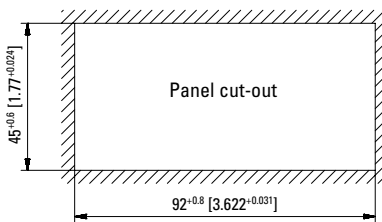
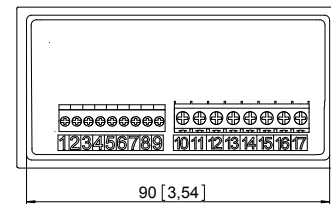
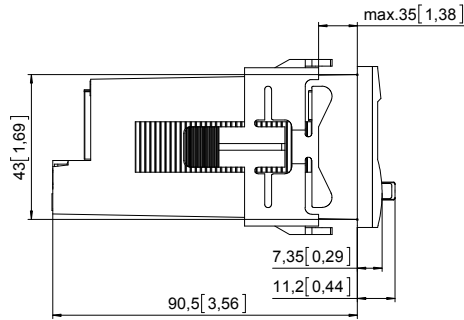
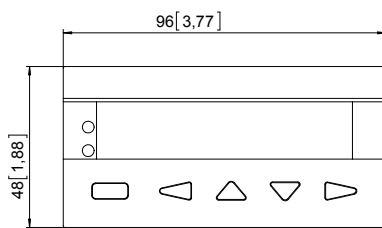

Product overview
Basics

Pulse counters

Preset counters

Hour meters
Timers

Frequency displays
Tachometers

Position displays

Multifunction
devices

Energy meters

Process devices

Temperature
devices

Strain-gauge
controllers

Accessories
Index

LED preset counters **Dual preset counters with 4 switch outputs and analog output** **572**



Counter series for demanding applications with two individually scalable encoder inputs, each A, /A, B, /B, for count frequencies up to 1 MHz per channel.

Programmable operating modes include position or event counter, totalizer, difference counter, cut-to-length display, diameter calculation and many more.



AC/DC 24/17...30V Power supply	000000 DIN 96 x 48 DIN front bezel	IP65 High protection level	max. 1 MHz 2 inputs	Operation with gloves	TTL, HTL and RS422 input	6/8 LED LED display	DC OUT 5 / 24 V 2 x sensor power supply	mA, V Analog output optional	4 Transistor output	RS 232 485 Interface
---	---	--------------------------------------	----------------------------------	------------------------------	---------------------------------	-------------------------------	--	--	-------------------------------	--------------------------------

Innovative

- 3 display values: counter 1, 2 as well as calculation-based display.
- 2 separate freely scalable count inputs: HTL or TTL (also with inverted inputs) max. input frequency 1 MHz/channel.
- Very bright LED display, 15 mm (6-digit) and 10 mm (8-digit) high.
- 4 freely programmable fast solid-state outputs, each with 350 mA output current.
- Step or tracking presets.
- Simple programming – with function codes, dependent on the operating mode selected.
- With 8 different fixed count functions, such as simple count, difference count and total count of both inputs, batch counter etc.

Compact and multifunctional

- One device caters for AC and DC power supplies.
- Simple programming with 4 keys and programmable dual functions.
- Can be used as counter or position display with limit values, where 2 values are monitored or calculated with respect to each other.
- 4 fast, programmable inputs with various functions, such as reset, gate, display memory (store), reference input or switching between the display values.
- Scalable analog output 0/4 ... 20 mA, ±10 V or 0 ... 10 V.
- RS232 interface as standard (RS485 optional), for parameter setting, readout of values or for modifications during operation.
- 2 auxiliary power supplies for sensors: 5.2 V DC and 24 V DC.

Order specifications

4 fast switch outputs and serial interface (RS232)

	Order no.
6 digits	6.572.0116.D05¹⁾
6 digits, RS485	6.572.0116.D75
6 digits, scalable analog outputs	6.572.0116.D95¹⁾
8 digits	6.572.0118.D05¹⁾
8 digits, RS485	6.572.0118.D75
8 digits, scalable analog outputs	6.572.0118.D95¹⁾

Delivery specification

- Controller 572
- Gasket
- Fastening set
- Instruction manual German/English

1) Stock types

Preset counters, electronic

LED preset counters Dual preset counters with 4 switch outputs and analog output **572**

Accessories	Dimensions in mm [inch]	Order no.
Mounting frame with cut-out 92 x 45 [3.62 x 1.77]	for snap-on mounting on 35 [1.38] top-hat DIN rail, for counters 96 x 48 [3.78 x 1.89]	grey G300005
OS6.0 software for parameter setting can be downloaded at www.kuebler.com		



Suitable gaskets as well as further accessories can be found in the accessories section or in the accessories area of our website at: www.kuebler.com/accessories.

Technical data

General technical data		
Display	6 digits	LED display, 15 mm mm [0.59"]high
	8 digits	LED display, 10 mm mm [0.39"]high
Operating temperature	0°C ... +45°C [+32°F ... +113°F] (non-condensing)	
Storage temperature	-25°C ... +70°C [-13°F ... +158°F]	

Electrical characteristics		
Power supply	24 V AC, + 10 % 24 (17 ... 30) V DC	
Current consumption DC	100 mA + current consumption encoder	
Connected load AC	15 VA	
Auxiliary power supply output for sensors	2 x 5.2 V DC, each 150 mA 2 x 24 V DC, each 120 mA	
EMC standards	EN 55011 class B, EN 61000-6-2, EN 61000-6-3, EN 61326-3-2	
Device safety	designed to protection class 2 application area	EN 61010 part 1 pollution level 2

Mechanical characteristics		
Housing	Noryl UL94-V-0	
Screw terminal	cable cross-section	max. 1.5 mm ² [AWG 25]
Protection	IP65 (front side)	
Weight	approx. 250 g [8.82 oz]	

Inputs		
Universal incremental encoder inputs		
Count frequency (per encoder)	RS422 and TTL with Inv. HTL asymmetric TTL asymmetric	2 1 MHz 200 kHz 200 kHz
Control inputs HTL		
Input resistor		4 3.3 kOhm
Switching level	LOW HIGH	< 2.5 V > 10 V
Min. pulse duration		50 µs

Outputs		
Switch outputs		
4 fast power transistors		5 ... 30 V DC, 350 mA
Reaction time		< 1ms ¹⁾
Inductive loads require a freewheeling diode		
Serial interface		
2400 ... 38400 Baud	RS232 RS485 (6.572.011X.D75)	
Analog outputs		
Current		0 / 4 ... 20 mA
Load		max. 270 Ohm
Voltage		0 ... +10 V (max. 2 mA)
Resolution		14 bit
Precision		0.1 %
Reaction time		< 1 m

Dimensions

Dimensions in mm [inch]

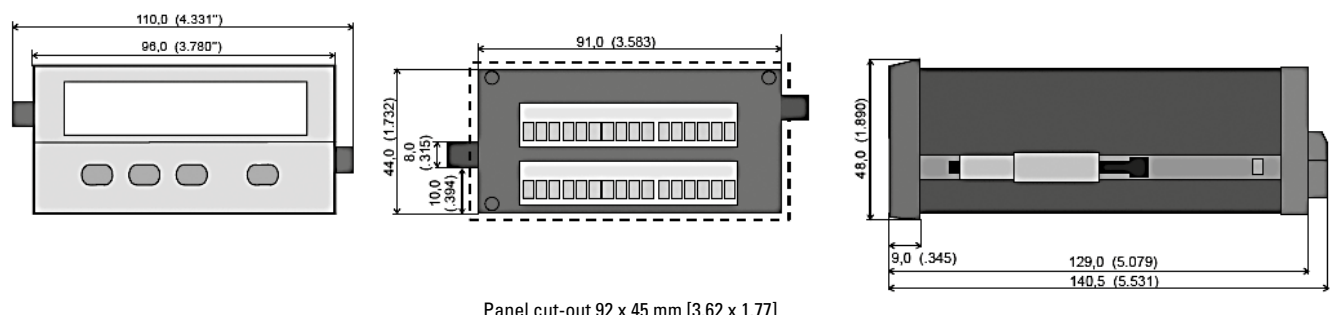

Panel cut-out 92 x 45 mm [3.62 x 1.77]

1) Intensive serial communication can temporarily prolong the reaction time

Product overview
 Basics
 Pulse counters
 Preset counters
 Hour meters
 Timers
 Frequency displays
 Tachometers
 Position displays
 Multifunction devices
 Energy meters
 Process devices
 Temperature devices
 Strain-gauge controllers
 Accessories
 Index

Preset counters, electronic

LED preset counters **Dual preset counters with 4 switch outputs and analog output** **572**

Application examples

Total position display

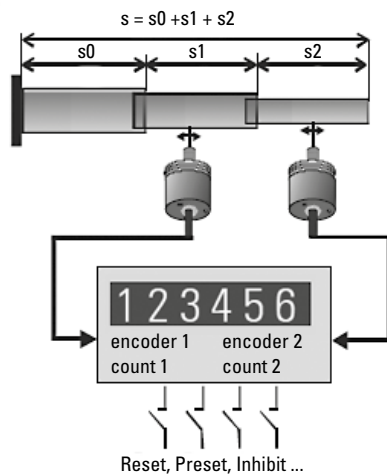

Difference position display

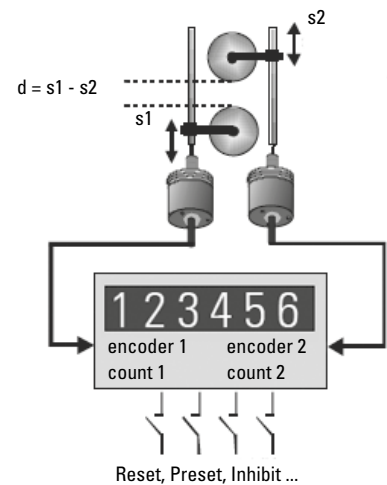

Measurement of the effective cut amount

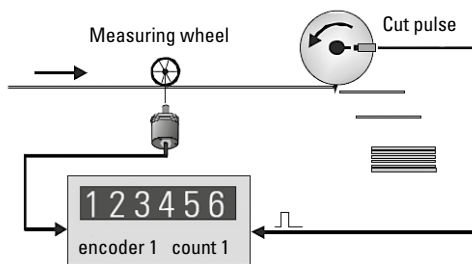

Monitoring of torsion, shafts or gear breakage

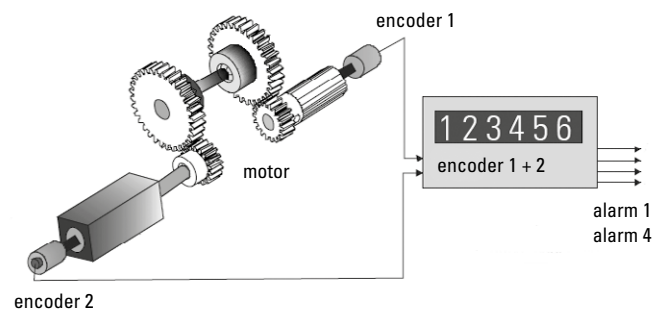

Terminal assignment

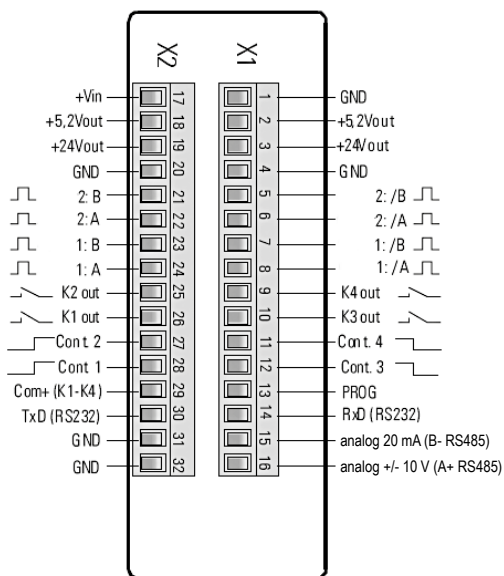

Connection examples

Example shows encoder with 5 V-supply and TTL / RS422-output

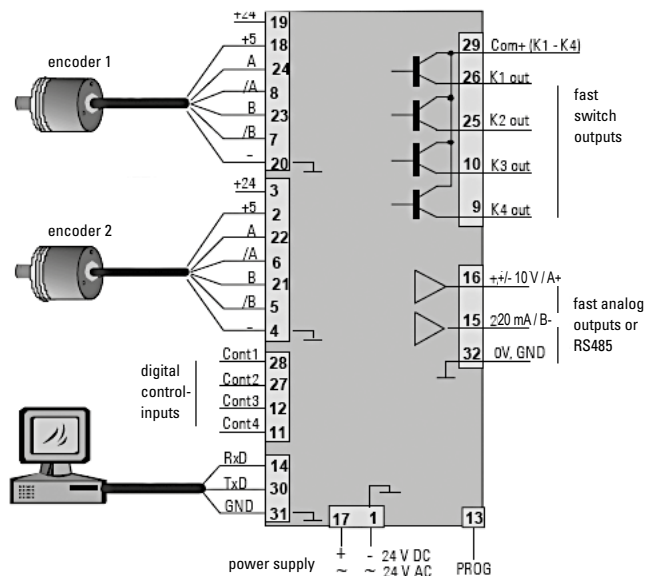

Preset counters, electronic

LED position preset counters

SSI o. incremental inputs / 4 switch outputs + analog output

575



Counter series for demanding applications with two individually scalable encoder inputs, each SSI master / SSI slave or A, /A, B, /B, for count frequencies up to 1 MHz per channel.

Programmable operating modes include position or event counter, totalizer, difference counter.



Power supply



DIN front bezel



High protection level

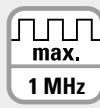

2 inputs



SSI input

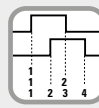

TTL, HTL and RS422 input



LED display

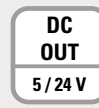

2 x sensor power supply

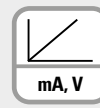

Analog output optional

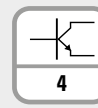

Transistor output



Interface

Innovative

- 3 display values: counter 1, 2 as well as calculation-based display.
- 2 separate freely scalable count inputs: SSI master, SSI slave or TTL incremental (also with inverted inputs) max. input frequency 1 MHz/channel.
- Very bright LED display, 15 mm (6-digit) and 10 mm (8-digit) high.
- 4 freely programmable fast solid-state outputs, each with 350 mA output current.
- Step or tracking presets.
- Simple programming – with function codes, dependent on the operating mode selected.
- With 8 different fixed count functions, such as simple count, difference count and total count of both inputs, separate display of the inputs.

Compact and multifunctional

- One device caters for AC and DC power supplies.
- Simple programming with 4 keys and programmable dual functions.
- Can be used as counter or position display with limit values, where 2 values are monitored or calculated with respect to each other.
- 4 fast, programmable inputs with various functions, such as reset, gate, display memory (store), reference input or switching between the display values.
- Scalable analog output 0/4 ... 20 mA, ± 10 V or 0 ... 10 V.
- RS232 interface as standard, for parameter setting, readout of values or for modifications during operation.
- 2 auxiliary power supplies for sensors: 5.2 V DC and 24 V DC.

Order specifications

4 fast switch outputs and serial interface (RS232)

- 6 digits
- 6 digits, scalable analog outputs
- 8 digits
- 8 digits, scalable analog outputs

Order no.

- 6.575.0116.D05**
- 6.575.0116.D95**
- 6.575.0118.D05**
- 6.575.0118.D95**

Delivery specification

- Controller 575
- Gasket
- Fastening set
- Instruction manual German/English

Accessories

Mounting frame

with cut-out 92 x 45 [3.62 x 1.77]

Dimensions in mm [inch]

for snap-on mounting on 35 [1.38] top-hat DIN rail,
for counters 96 x 48 [3.78 x 1.89]

grey

Order No.

G300005



OS6.0 software for parameter setting

can be downloaded at www.kuebler.com

Suitable gaskets as well as further accessories can be found in the accessories section or in the accessories area of our website at: www.kuebler.com/accessories.

Preset counters, electronic

LED position preset counters SSI o. incremental inputs / 4 switch outputs + analog output 575

Technical data

General technical data		
Display	6 digits	LED display, 15 mm [0.59"] high
	8 digits	LED display, 10 mm [0.39"] high
Operating temperature	0°C ... +45°C [+32°F ... +113°F] (non-condensing)	
Storage temperature	-25°C ... +70°C [-13°F ... +158°F]	

Electrical characteristics		
Power supply	24 V AC, + 10 % 24 (17 ... 30) V DC	
Current consumption DC	100 mA + current consumption encoder	
Connected load AC	15 VA	
Auxiliary power supply output for sensors	2 x 5.2 V DC, each 150 mA 2 x 24 V DC, each 120 mA	
EMC standards	EN 55011 class B, EN 61000-6-2, EN 61000-6-3, EN 61326-3-2	
Device safety	designed to protection class 2 application area	EN 61010 part 1 pollution level 2

Mechanical characteristics		
Housing	Noryl UL94-V-0	
Screw terminal	cable cross-section	max. 1.5 mm ² [AWG 25]
Protection	IP65 (front side)	
Weight	approx. 250 g [8.82 oz]	

Inputs		
Universal SSI incremental encoder inputs		
Number	2 SSI or 1 SSI + 1 incremental	
Count frequency (per encoder)	RS422 and TTL with Inv. 1 MHz	
	SSI master	1 MHz (max. 32 bit)
	SSI slave	1 MHz (max. 32 bit)
Control inputs HTL		
Number	4	
Input resistor	3.3 kOhm	
Switching level	LOW	< 2.5 V
	HIGH	> 10 V
Min. pulse duration	50 µs	

Outputs		
Switch outputs		
4 fast power transistors	5 ... 30 V DC, 350 mA	
Reaction time	< 1ms ¹⁾	
Inductive loads require a freewheeling diode		
Serial interface	RS232, 2400 ... 38400 Baud	
Analog outputs		
Current	0 / 4 ... 20 mA	
Load	max. 270 Ohm	
Voltage	0 ... +10 V (max. 3 mA)	
Resolution	14 bit	
Precision	0.1 %	
Reaction time	< 1 m	

Application examples

Total position display

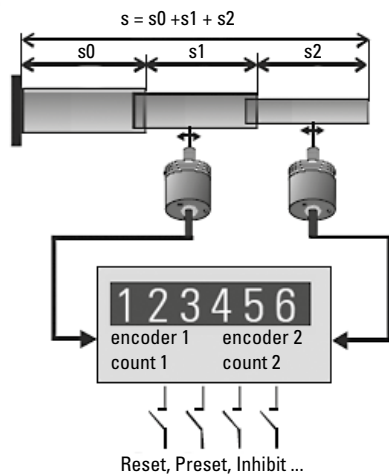

Difference position display

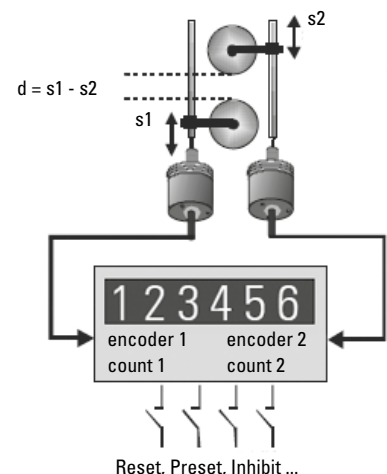

Independent individual operation

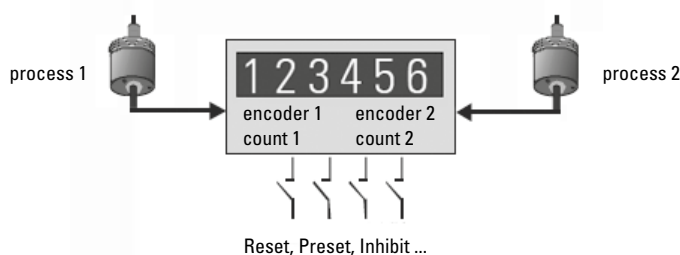

1) Intensive serial communication can temporarily prolong the reaction time

Product overview
Basics
Pulse counters
Preset counters
Hour meters
Timers
Frequency displays
Tachometers
Position displays
Multifunction devices
Energy meters
Process devices
Temperature devices
Strain-gauge controllers
Accessories
Index

LED position preset counters **SSI o. incremental inputs / 4 switch outputs + analog output** **575**

Terminal assignment

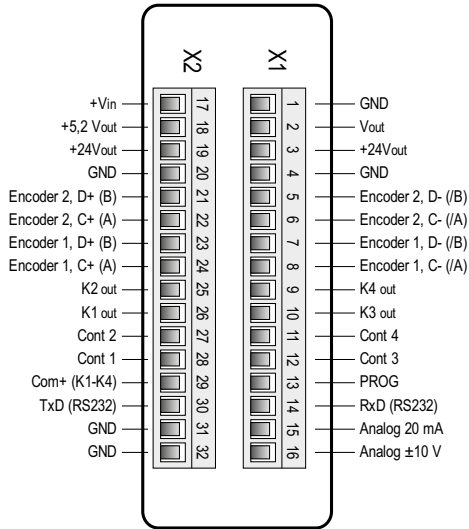

Connection examples

Example shows encoder with 5 V-supply and TTL / RS422-output

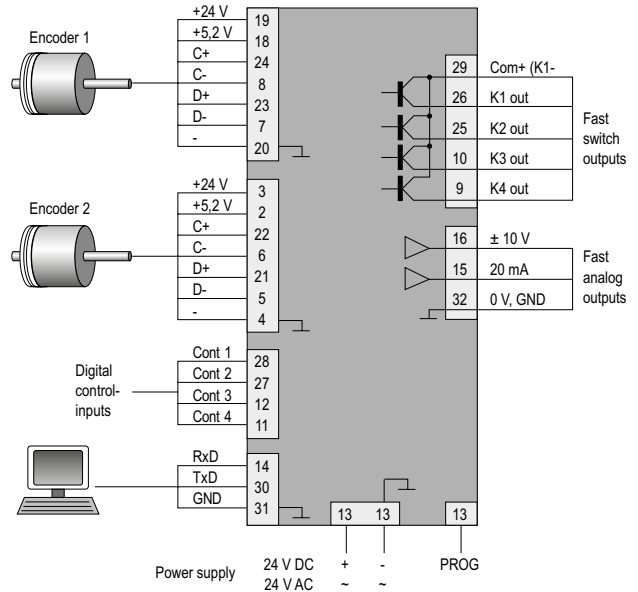

Dimensions

Dimensions in mm [inch]

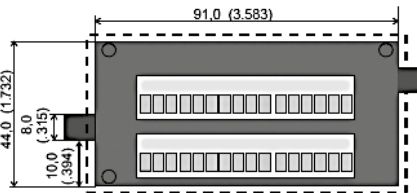
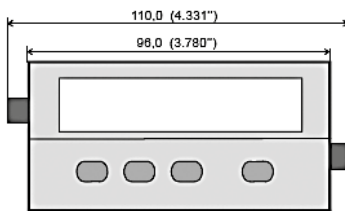

Panel cut-out 92 x 45 mm [3.62 x 1.77]

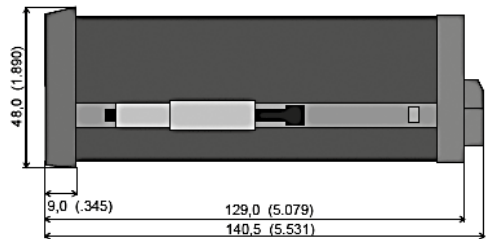

Preset counters, electromechanical

Standard counters	Adding, 5 digits (AC+DC)	BVa 15
-------------------	--------------------------	--------



The electromechanical preset counters BVa 15 (with manual reset) boast a robust construction. They are ideal for use in harsh industrial environments as stand-alone counters or as plug-in variants in combination with additional B, BVa, HB or HVA counters.

Display shows actual count and preset value.

Product overview
Basics

Pulse counters

Preset counters

Hour meters
Timers

Frequency displays
Tachometers

Position displays

Multifunction
devices

Energy meters

Process devices

Temperature
devices

Strain-gauge
controllers

Accessories
Index

Characteristics

- 5-digit adding preset counter with stationary preset value.
- Manual reset to zero.
- Potential free changeover contact (microswitch) on reaching the preset.
- Contact switches when preset value is reached and remains switched until reset to zero.
- Counters without front bezel fit into bezel F2B and can be combined in RM 50 x 50 mm.

Benefits

- Can be combined with counters of the B, BVa, HB and HVA series using the socket boxes of the pluggable versions.
- Count value and preset constantly visible.
- Versions with transparent cover, sealing cover, zero reset key-lock.

Applications

Piece counting, automation.

Type series

Description

(Reset manual)

Without front bezel, plugs into socket box

Front bezel 1, mounting holes

Mounting clip

Front bezel 3, mounting holes

Type

BVa 15.01

BVa 15.11

BVa 15.21

BVa 15.31

Delivery specification

Counter complete with socket box

Order information

- Art. no.

- For special voltages, please give type, voltage and series e.g.: BVa 15.31, 12 V DC ...

Further versions, fully assembled (on request)

Counter with lockable reset

BVa 15.21 vs



Counter with transparent cover

Dv BVa 15.31 lockable



Dvs BVa 15.31 key lockable



Type / Counting mechanism

Voltage	Type max.	Pulse frequency min.	Pulse on time min.	Pulse interval	Pulse ratio	On-time approx.	Power consump. ripple max.	Permi. residual (non-condensing)	Operating temp.
V DC	1	25 Hz	24 ms	16 ms	3 : 2	100 %	3 W	48 %	-10°C ... +60°C [+14°F ... +140°F]
V AC	a	18 Hz	27.7 ms	27.7 ms	1 : 1	100 %	3 VA	-	-10°C ... +55°C [+14°F ... +131°F]

Preset counters, electromechanical

Standard counters	Adding, 5 digits (AC+DC)	BVa 15	
Accessories		Dimensions in mm [inch]	Order no.
Front bezel type F2B	for cut-out 54 x 54 [2.13 x 2.13], with screw mounting for plug-in counters BVa 15.0x in socket box type 946.1	beige black	G007503 G007504
Socket box type 946.1	for counters BVa 15.01, can be used for plug-in connections, in front bezel F2B	black	G008439
Sealing cover type K2, IP65	for front bezel 75 x 60 [2.95 x 2.36] with screw mounting, for elektrom. counters and via adapter front bezel T008860 for counters 48 x 48 [1.89 x 1.89]	grey black	G008302 G008303
Mounting frame with cut-out 50 x 50 [2.36 x 2.36] via separate adapter also for 45 x 45 [1.77 x 1.77]	for snap-on mounting on 35 [1.38] top-hat DIN rail, for counters 48 x 48 [1.89 x 1.89], 53 x 53 [2.09 x 2.09] and 55 x 55 [2.17 x 2.17]	chromated	G300003
DIN rail mount SR 3	for snap-on mounting on 35 [1.38] top-hat DIN rail		G300002
Replacement parts			Order no.
Transparent cover, IP65	type 2 Dv, suitable for Dv BVa 15 and Dv HVa 15 type 2 Dvs, suitable for Dvs BVa 15 and Dvs HVa 15	lockable key lockable	G008141 G008151
Key for key-locking zero reset			G050265

Suitable gaskets, other accessories and installation examples for optional accessories can be found in chapter Accessories or in the Accessories section under: www.kuebler.com/accessories.

Technical data	
Electrical connection	counter: tinned tabs \varnothing 1.6 mm [0.063"] with push-on connectors socket box: tinned plated tabs 0.8 x 2.8 mm [0.032 x 0.11"]
Rated voltages	counting mechanism: 12 / 24 / 48 / 115 V DC \pm 10 % 24 / 48 / 115 / 230 V AC \pm 10 %
Height of figures	counter: 4.5 mm [0.18"] preset: 4 mm [0.16"]
Color of housing	grey: Art. no. x.xxx.xx0.xxx black: Art. no. x.xxx.xx1.xxx
Color of figures	counter: white on black preset: yellow on black
Counting mechanism shaft	stainless steel
Mounting position	any
Service life	approx. 100×10^6 pulses
Protection	IP40 (front side)
Weight	approx. 130 g [4.59 oz]
EMC standards	EN 55011 class B, EN 61000-6-2, EN 61000-6-3,
Device safety	designed to protection class 2 application area: pollution level 2
Test voltage	2000 V, effective
Switching contact	1 change over contact (micro switch), release in 2nd half-step on the preset number
Loading (max) (with resistive Load.)	AC : 250 V AC 2.0 A DC : 24 V DC 2.0 A 60 V DC 0.7 A 115 V DC 0.4 A 230 V DC 0.2 A
Suitable spark quenching is required with inductive load, reducing the max. current to 60 %	

Options	
Key-locking zero reset	housing grey: Art. no.: 2.1X0.XX6.XXX housing black: Art. no.: 2.1X0.XX7.XXX
Lockable transparent cover (IP65)	Dv BVa counter with front bezel 3 Art. no.: 2.1X0.7XX.XXX
Key lockable transparent cover (IP65)	Dvs BVa counter with front bezel 3 Art. no.: 2.1X0.8XX.XXX
Flexible sealing cover K2 (IP54)	K2 BVa counter with front bezel 3 Art. no.: 2.1X0.6XX.XXX
Screw terminal connection	Art. no.: 2.XXX.XXX.XXX.023
Flat pin connection 2.8 x 0.8 mm (on request)	Art. no.: 2.XX7.XXX.XXX

Connection diagrams

DC

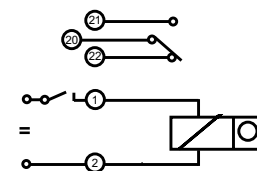

AC

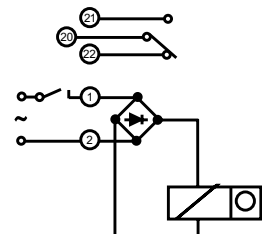

Preset counters, electromechanical

Standard counters **Adding, 5 digits (AC+DC)** **BVa 15**

Without front bezel,
plugs into socket box type 946.1
Type BVa 15.01

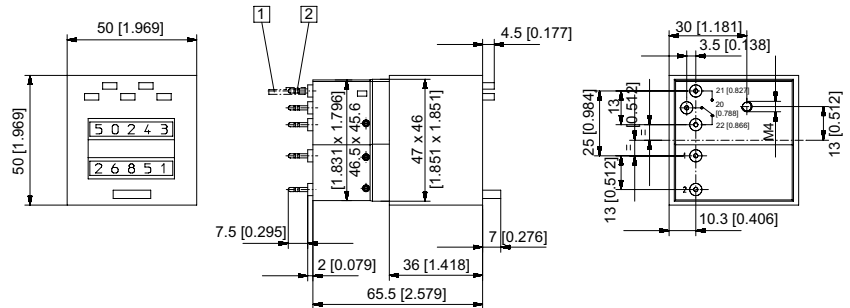

1 Push-on connector \varnothing 1.5 [0.059] tinned 2 Round pin \varnothing 1.6 [0.063] tinned
Color of housing grey (standard)

Type	Voltage	Display	Art. no.		
			24 V	115 V	230 V
BVa 15.01	DC (25 Hz)	5 digits	2.100.010.033	–	–
	AC (18 Hz)		2.100.010.061	2.100.010.064	2.100.010.066

Color of housing black: Art. no. 2.1X0.011.XXX

Front bezel 1,
with mounting holes
Type BVa 15.11

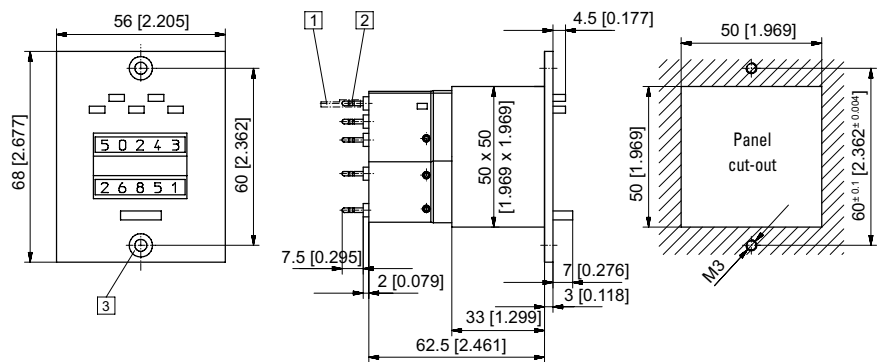

1 Push-on connector \varnothing 1.5 [0.059] tinned 2 Round pin \varnothing 1.6 [0.063] tinned 3 Countersinking Af3 DIN 74
Color of housing grey (standard)

Type	Voltage	Display	Art. no.		
			24 V	115 V	230 V
BVa 15.11	DC (25 Hz)	5 digits	2.100.110.033	–	–
	AC (18 Hz)		2.100.110.061	2.100.110.064	2.100.110.066

Color of housing black: Art. no. 2.1X0.111.XXX

Preset counters, electromechanical

Standard counters Adding, 5 digits (AC+DC) BVa 15

With mounting clips
Type BVa 15.21

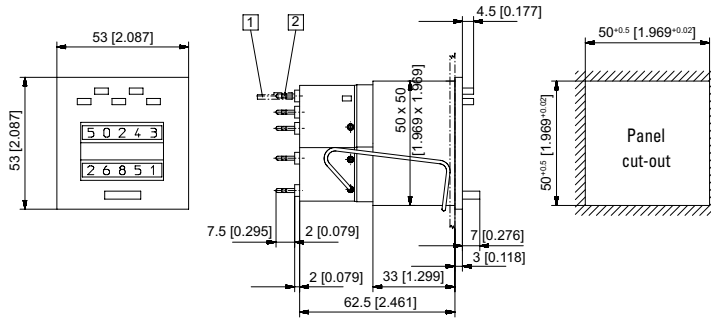

1 Push-on connector \varnothing 1.5 [0.059] tinned 2 Round pin \varnothing 1.6 [0.063] tinned
Color of housing grey (standard)

Type	Voltage	Display	Art. no.		
			24 V	115 V	230 V
BVa 15.21	DC (25 Hz)	5 digits	2.100.210.033 ¹⁾	-	-
	AC (18 Hz)		2.100.210.061	2.100.210.064	2.100.210.066 ¹⁾
Color of housing black: Art. no. 2.1X0.211.XXX			Further stock types: Art. no. 2.100.211.033		

Front bezel 3,
with mounting holes
Type BVa 15.31

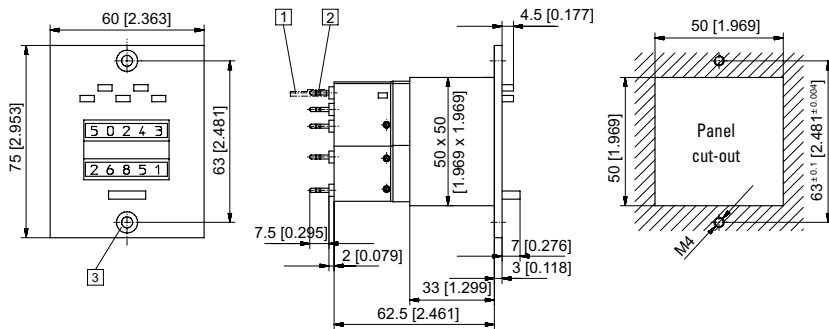

1 Push-on connector \varnothing 1.5 [0.059] tinned 2 Round pin \varnothing 1.6 [0.063] tinned 3 Countersinking Af3 DIN 74
Color of housing grey (standard)

Type	Voltage	Display	Art. no.		
			24 V	115 V	230 V
BVa 15.31	DC (25 Hz)	5 digits	2.100.310.033	-	-
	AC (18 Hz)		2.100.310.061	2.100.310.064	2.100.310.066
Color of housing black: Art. no. 2.1X0.311.XXX			Further stock types: BVa 15.31.4sw 24 V DC / Art. no. 2.107.311.013		

Standard counters **Adding, 5 digits (AC+DC)** **BVa 15**

Mounting examples for optional accessories

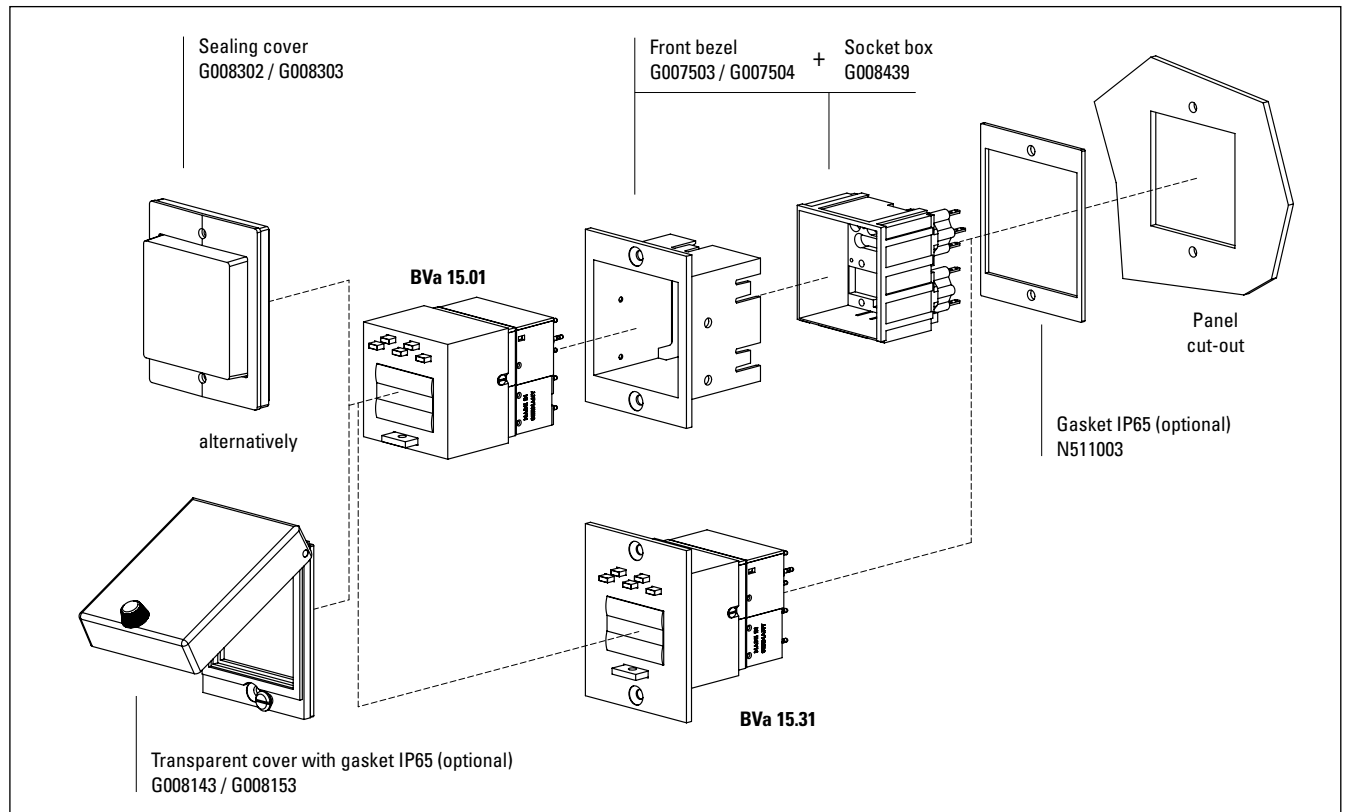

- Product overview
- Basics
- Pulse counters
- Preset counters
- Hour meters
- Timers
- Frequency displays
- Tachometers
- Position displays
- Multifunction devices
- Energy meters
- Process devices
- Temperature devices
- Strain-gauge controllers
- Accessories
- Index

Preset counters, electromechanical

Standard counters

Subtracting, 2 or 3 digits (AC+DC)

MVs 13



The electromechanical preset counters MVs 13 (with manual and manual/electrical reset) boast a robust construction with very small dimensions.

They are ideal for use in harsh industrial environments. The subtracting counters are set to a value via the front keys, the signal occurs when the count value reaches 0.

Characteristics

- 2- or 3-digit subtracting preset counter.
- Manual or manual and electrical reset.
- Potential free changeover contact (microswitch) on reaching zero.
- Contact switches for "0" count position and remains unswitched until reset to zero.

Benefits

- Delivery complete with push-on connectors.
- Very small dimensions.
- Versions with sealing cover on request.

Applications

Piece counting, batch quantities and automation.

Type series

	3 digits manual reset	3 digits manual and electr. reset	2 digits manual reset	2 digits manual and electr. reset
Front bezel with mounting holes	MVs 13.11	MVs 13.13	MVs 13.11/2	MVs 13.13/2
Front bezel with mounting clip	MVs 13.21	MVs 13.23	MVs 13.21/2	MVs 13.23/2

Accessories

	Dimensions in mm [inch]	Order no.
Sealing cover type KV3, IP65	for front bezel 39 x 68 [1.54 x 2.68] , with screw mounting	transparent, grey transparent, black
		G008310 G008311

Suitable gaskets as well as further accessories can be found in the accessories section or in the accessories area of our website at: www.kuebler.com/accessories.

Product overview
Basics

Pulse counters

Preset counters

Hour meters
Timers

Frequency displays
Tachometers

Position displays

Multifunction
devices

Energy meters

Process devices

Temperature
devices

Strain-gauge
controllers

Accessories
Index

Preset counters, electromechanical

Standard counters	Subtracting, 2 or 3 digits (AC+DC)	MVs 13
--------------------------	---	---------------

Technical data	
Electrical connection	tinned flat pins 0.8 x 2.8 mm [0.032 x 0.11"] (with push on connectors)
Rated voltages	count mechanism 12 / 24 / 48 / 115 / 230 V DC ±10 % 24 / 48 / 115 / 230 V AC ±10 % reset magnet 24 / 48 / 115 / 230 V DC ±10 % 24 / 48 / 115 / 230 V AC ±10 %
Height of figures	4 mm [0.16"]
Color of housing	similar to RAL 7001
Color of figures	white on black
Counting mechanism shaft	stainless steel
Mounting position	any
Service life	approx. 100 x 10 ⁶ pulses
Protection	IP40 (front side)
Weight	approx. 150 g [5.29 oz], with electrical reset approx. 190 g [6.70 oz]
EMC standards	EN 55011 class B, EN 61000-6-2, EN 61000-6-3
Device safety	designed to EN 61010 part 1 protection class 2 application area pollution level 2
Test voltage	2000 V, effective
Switching contact	1 change over contact (micro switch), release in 2nd half-step exactly at zero
Load (max.) (with resistive load)	AC 250 V AC 2.0 A DC 24 V DC 2.0 A 60 V DC 0.7 A 115 V DC 0.4 A 230 V DC 0.2 A
With inductive: suitable spark quenching is required on inductive load, reducing the max. current to approx. 60 %	
Electrical reset	on time 10 % max. 40 seconds minimum pulse time 0.25 sec. power consumption 12 W at DC, 14 VA at AC

Options
Electrical reset only

Connection diagrams

Manual reset

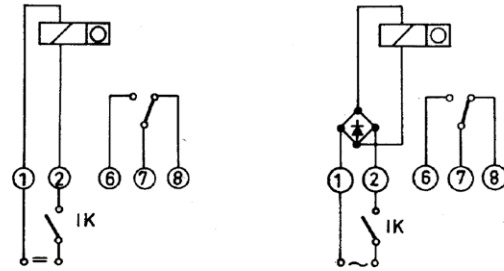

Manual and electrical reset

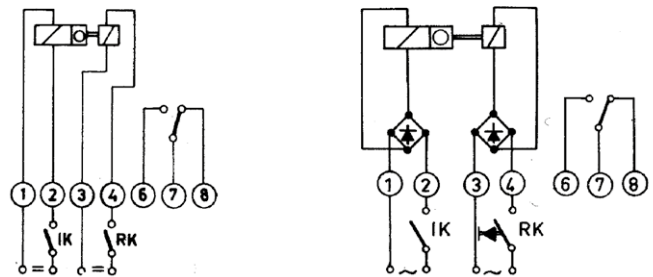

Type / Counting mechanism									
Voltage	Type	Pulse frequency max.	Pulse on time min.	Pulse interval min.	Pulse ratio	On-time	Power consump. approx.	Permi. residual ripple max.	Operating temp. (non-condensing)
V DC	1	25 Hz	24 ms	16 ms	3 : 2	100 %	4 W	48 %	-10°C ... +45°C [+14°F ... +113°F]
V AC	a	18 Hz	22.2 ms	33.3 ms	2 : 3	100 %	4.5 VA	—	-10°C ... +45°C [+14°F ... +113°F]

Preset counters, electromechanical

Standard counters

Subtracting, 2 or 3 digits (AC+DC)

MVs 13

Front bezel with mounting holes,
manual reset

Type MVs 13.11, MVs 13.11/2

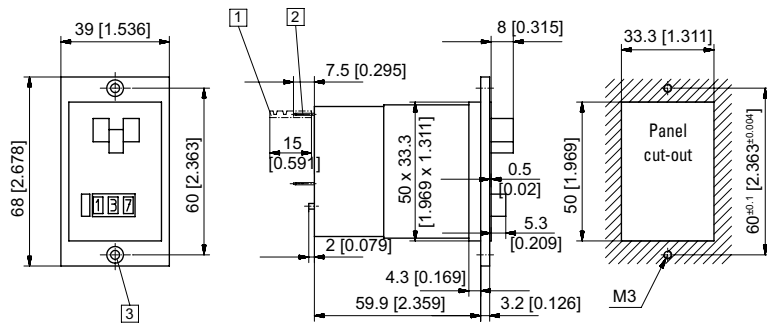

- 1 Push-on connector 0.8 x 2.8 [0.032 x 0.11] tinned 2 Flat pin 0.8 x 2.8 [0.032 x 0.11] tinned
3 Countersinking Af3 DIN 74 Color of housing grey (standard)

Voltage	Type / Art. no.	MVs 13.11 (display 3 digits)			MVs 13.11/2 (display 2 digits)		
		24 V	115 V	230 V	24 V	115 V	230 V
DC (25 Hz)		2.300.110.033	–	–	2.310.110.033	–	–
AC (18 Hz)		2.300.110.061	2.300.110.064	2.300.110.066	2.310.110.061	2.310.110.064	2.310.110.066

Front bezel with mounting holes,
manual and electrical reset

Type MVs 13.13, MVs 13.13/2

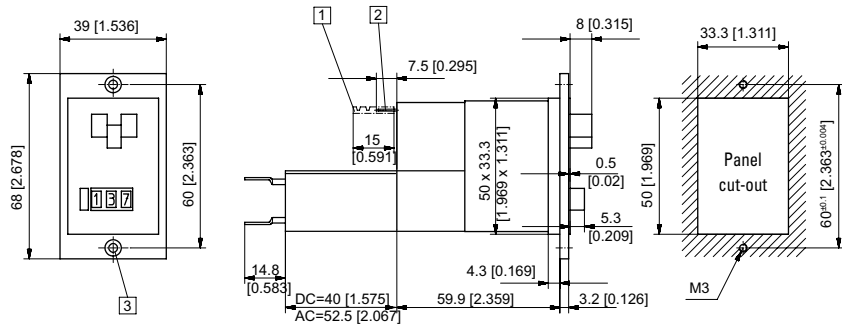

- 1 Push-on connector 0.8 x 2.8 [0.032 x 0.11] tinned 2 Flat pin 0.8 x 2.8 [0.032 x 0.11] tinned
3 Countersinking Af3 DIN 74 Color of housing grey (standard)

Voltage	Type / Art. no.	MVs 13.13 (display 3 digits)			MVs 13.13/2 (display 2 digits)		
		24 V	115 V	230 V	24 V	115 V	230 V
DC (25 Hz)		2.300.130.033	–	–	2.310.130.033	–	–
AC (18 Hz)		2.300.130.061	2.300.130.064	2.300.130.066	2.310.130.061	2.310.130.064	2.310.130.066

Preset counters, electromechanical

Standard counters **Subtracting, 2 or 3 digits (AC+DC)** **MVs 13**

Front bezel with clip mounting, manual reset

Type MVs 13.21, MVs 13.21/2

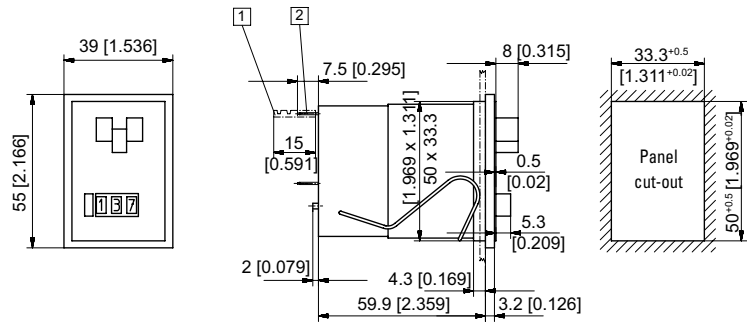

1 Push-on connector 0.8 x 2.8 [0.032 x 0.11] tinned 2 Flat pin 0.8 x 2.8 [0.032 x 0.11] tinned
Color of housing grey (standard)

Voltage	Type / Art. no.	MVs 13.21 (display 3 digits)			MVs 13.21/2 (display 2 digits)		
		24 V	115 V	230 V	24 V	115 V	230 V
DC (25 Hz)		2.300.210.033	–	–	2.310.210.033	–	–
AC (18 Hz)		2.300.210.061	2.300.210.064	2.300.210.066	2.310.210.061	2.310.210.064	2.310.210.066

Color of housing black: Art. no. 2.3X0.211.XXX

Front bezel with clip mounting, manual and electrical reset

Type MVs 13.23, MVs 13.23/2

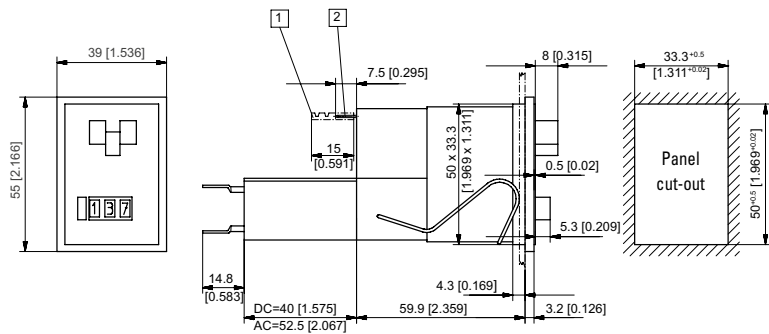

1 Push-on connector 0.8 x 2.8 [0.032 x 0.11] tinned 2 Flat pin 0.8 x 2.8 [0.032 x 0.11] tinned
Color of housing grey (standard)

Voltage	Type / Art. no.	MVs 13.23 (display 3 digits)			MVs 13.23/2 (display 2 digits)		
		24 V	115 V	230 V	24 V	115 V	230 V
DC (25 Hz)		2.300.230.033	–	–	2.310.230.033	–	–
AC (18 Hz)		2.300.230.061	2.300.230.064	2.300.230.066	2.310.230.061	2.310.230.064	2.310.230.066

Color of housing black: Art. no. 2.3X0.231.XXX

Product overview
Basics
Pulse counters
Preset counters
Hour meters
Timers
Frequency displays
Tachometers
Position displays
Multifunction devices
Energy meters
Process devices
Temperature devices
Strain-gauge controllers
Accessories
Index

Preset counters, electromechanical

Standard counters

Subtracting, 6 digits (AC+DC)

MVs 16

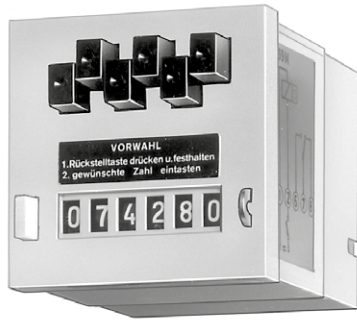

The electromechanical preset counters MVs 16 (with manual and electrical reset) boast a robust construction. They are ideal for use in harsh industrial environments. The subtracting counters are set to a value via the keys on the front, the signal occurs when the count value reaches 0.

Characteristics

- 6-digit subtracting preset counter.
- Manual and electrical reset.
- Potential free changeover (microswitch) on reaching zero.
- Contact switches for "0" count position and remains unswitched until reset to zero.

Benefits

- Delivery complete with push-on connectors.
- Versions with transparent cover or sealing cover on request.

Applications

Piece counting, batch quantities and automation.

Type series

Description	Type
Front bezel 2 with mounting clip	MVs 16.23

Accessories	Dimensions in mm [inch]	Order no.
Socket box, type 926.1	for counters MVs 16 for plug-in connections	transparent G008433
Mounting frame with cut-out 50 x 50 [2.36 x 2.36] via separate adapter also for 45 x 45 [1.77 x 1.77]	for snap-on mounting on 35 [1.38] top-hat DIN rail, for counters 48 x 48 [1.89 x 1.89], 53 x 53 [2.09 x 2.09] and 55 x 55 [2.17 x 2.17]	chromated G300003

Suitable gaskets as well as further accessories can be found in the accessories section or in the accessories area of our website at: www.kuebler.com/accessories.

Type / Counting mechanism									
Voltage	Type max.	Pulse frequency min.	Pulse on time min.	Pulse interval	Pulse ratio	On-time approx.	Power consump. ripple max.	Permi. residual (non-condensing)	Operating temp.
V DC	1	25 Hz	24 ms	16 ms	3 : 2	100 %	4 W	48 %	-10°C ... +45°C [+14°F ... +113°F]
V AC	a	18 Hz	22.2 ms	33.3 ms	2 : 3	100 %	4.5 VA	–	-10°C ... +45°C [+14°F ... +113°F]

Product overview
Basics
Pulse counters
Preset counters
Hour meters
Timers
Frequency displays
Tachometers
Position displays
Multifunction devices
Energy meters
Process devices
Temperature devices
Strain-gauge controllers
Accessories
Index

Preset counters, electromechanical

Standard counters Subtracting, 6 digits (AC+DC) MVs 16

Technical data	
Electrical connection	tinned flat pins 0.8 x 2.8 mm [0.032 x 0.11"] (with push-on connectors) socket box 0.3 x 2.8 mm [0.012 x 0.11"]
Rated voltages	counting mechanism 12 / 24 / 48 / 115 V DC ±10 % 24 / 48 / 115 / 230 V AC ±10 % reset magnet 24 / 48 / 115 V DC ±10 % 24 / 48 / 115 / 230 V AC ±10 %
High of figures	4 mm
Color of housing	similar to RAL 7001
Color of figures	white on black
Counting mechanism shaft	stainless steel
Mounting position	any
Service life	approx. 100 x 10 ⁶ pulses
Protection	IP40 (front side)
Weight	approx. 170 g [6.00 oz], with electrical reset approx. 210 g [7.41 oz]
EMC standards	EN 55011 class B, EN 61000-6-2, EN 61000-6-3
Device safety	designed to protection class 2 application area pollution level 2
Test voltage	2000 V AC, effective
Switching contact	1 change over contact (micro switch), contact making in 2nd half step at zero
Load (max.) (at resistive load)	AC 250 V AC 2.0 A DC 24 V DC 2.0 A 60 V DC 0.7 A 115 V DC 0.4 A 230 V DC 0.2 A
At inductive load: suitable spark quenching is required on inductive load, reducing the max. current to approx. 60%	

Options	
Electrical reset	on time 20 % max. 1 minute minimum pulse time 0.25 sec. power consumption 10 W at DC, 14 VA at AC

Connection diagrams

Manual and electrical reset

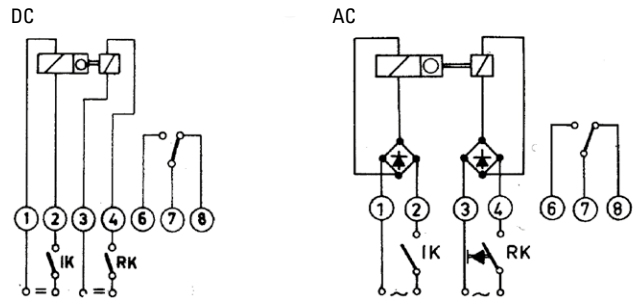

Front bezel 2 with mounting clips, manual and electrical reset Type MVs 16.23

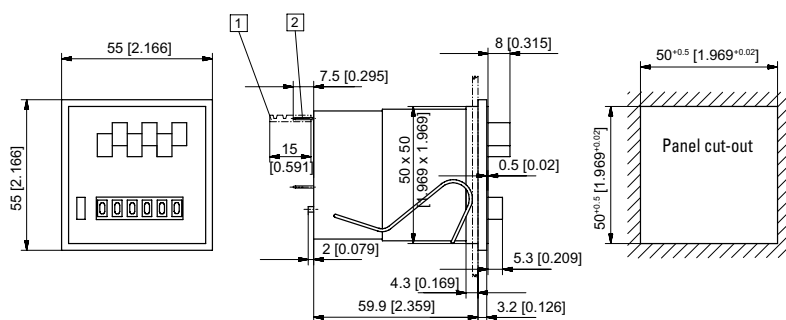

1 Push-on connector 0.8 x 2.8 tinned [0.032 x 0.11] 2 Flat pin 0.8 x 2.8 [0.032 x 0.11] tinned
Color of housing grey (standard)

Type	Voltage	Display	Art. no.		
			24 V	115 V	230 V
MVs 16.23	DC (25 Hz)	6-digits	2.320.230.033	—	—
	AC (18 Hz)	6-digits	2.320.230.061	2.320.230.064	2.320.230.066



Product overview
Basics

Pulse counters

Preset counters

Hour meters
Timers

Frequency displays
Tachometers

Position displays

Multifunction
devices

Energy meters

Process devices

Temperature
devices

Strain-gauge
controllers

Accessories
Index

Hour meters / Timers

Hour meters / timers, electronic		Type	Page
LCD hour meters	Max. time range 99999 h 59 min or 99999.99 h (battery)	Codix 134	158
	Max. time range 9999 h 59 min 59 sec or 9999999.9 sec (battery)	Codix 135	161
	Adding counter, 99999.99 h (DC)	Codix 141	164
LCD service timer	Service timer, 99999.99 h (DC)	Codix 143	164
LED timers	h, min, sec or hh.mm.ss (DC)	Codix 523	167
	Multifunctional – pulse, frequency, time (DC)	Codix 524	240
	Universal with dual functions 4 combinations (DC)	Codix 52U	250
	h, min, sec or hh.mm.ss (AC+DC)	Codix 543	170
	Multifunctional – pulse, frequency, time (AC+DC)	Codix 544	244
	Universal with dual functions 4 combinations (AC+DC)	Codix 54U	258
LCD time modules	Max. time range 9999.99 h (DC)	194	173
	Max. time range 99999.9 h (DC)	198	175
Hour meters / timers, electromechanical		Type	Page
Micro timers	High shock resistance (DC)	HK 47	177
	Many different installation options (DC)	HK 07 / AHK 07	179
Timers with DIN dimensions	Small format (AC+DC)	HK 17	182
	DIN counter for panel mount, 48 x 24 mm (AC+DC)	H 37	185
	DIN counter for panel mount, 48 x 48 mm (AC+DC)	H 57	189
Timers for DIN rail mounting	DIN rail housing, 48 x 48 mm (AC+DC)	AH 57	189
	Micro DIN rail housing (AC+DC)	SHK 07.1	192
	DIN rail housing, 2 modules wide (AC+DC)	SH 17	194
Timers, round design	With LED run indicator (AC+DC)	HR 47	196
	High protection rating (AC+DC)	HR 76	198
Standard timers	9999.99 h / 99999.9 h with reset (AC+DC)	HB 26	200
	999999.9 h / 99999.99 h without reset (AC+DC)	HB 27	204
Dual function counters	Pulse + time / 2 x time (AC+DC)	HC 77	208
	Pulse + time for DIN rail (AC+DC)	SHC 77	211
	Energy + time (AC)	HW 66 / HW 66 M	266
Time preset counters, electronic		Type	Page
LCD time preset counters	1 preset – pulse, time (battery)	Codix 901	120
	1 or 2 presets – pulse, time – 5 kHz (AC+DC)	Codix 907 / 908	124
	Multifunctional – pulse, frequency, time – 1 ... 6 presets (AC+DC)	Codix 923 / 924	127
Time preset counters with multicolor or LED look	Multifunctional – pulse, frequency, time – 1 ... 6 presets (AC+DC)	Codix 923 / 924	127
LED time preset counter	Multifunctional – pulse, frequency, time – 65 kHz, 2 presets (AC+DC)	Codix 560	134
LCD touch time preset counter	 Pulse, frequency, time (also reciprocal) – (AC+DC)	571T	247
Time preset counter, electromechanical		Type	Page
Standard time preset counter	Adding with mechanical reset (AC+DC)	HVa 15	213

Product overview
Basics
Pulse counters
Preset counters
Hour meters
Timers
Frequency displays
Tachometers
Position displays
Multifunction devices
Energy meters
Process devices
Temperature devices
Strain-gauge controllers
Accessories
Index

Hour meters / timers, electronic

LCD hour meters	Max. time range 99999 h 59 min or 99999.99 h	Codix 134
------------------------	---	------------------



The Codix 134 is a simple battery-powered hour meter for PNP, NPN and high voltage applications. Its 7-digit LCD display with optional backlighting can display various time ranges.



Battery powered	Timer	Input type	Pulse voltage	Pulse voltage	Temperature range	High protection level	DIN front bezel	LCD display	Lockable reset

Powerful

- High quality LCD display with 8 mm high figures – optional display backlighting.
- Time range hours with minutes or industry minutes
1 pulse = 36 sec programmable via control input.
- Battery lifetime 8 years.
- High voltage versions for 10 ... 260 V AC/DC voltage pulses, thus to be connected directly via contactors, relays and motors.
- Very high accuracy: 100 ppm.

Simple

- Screw terminals, RM 5 mm.
- Reset key lockable via the input 'Reset Enable'.
- According to version for PNP, NPN switching level or high voltage version for 10 ... 260 V AC/DC switching voltage.
- Accumulated time is always readable thanks to battery powering.
- High protection level IP65.

Order code 6.134 . 012 . 8XX

a Backlighting
5 = without ¹⁾
6 = with

b Input type: operating hours counting

Input type	INP A		INP B	
0 = adding ¹⁾	–		0 ... 0.7 V DC	NPN
1 = adding ¹⁾	–		4 ... 30 V DC	PNP
3 = adding ¹⁾	10 ... 260 V AC/DC	AC/DC	10 ... 260 V AC/DC	AC/DC

Delivery specification

- Timer
- Mounting clip
- Front bezel for screw mounting (T008181) 56 x 40 mm [2.20 x 1.57"], panel cut-out 50 x 25 mm [1.97 x 0.98"]
- Front bezel for clip mounting (T008180) 53 x 28 mm [2.09 x 1.10"], panel cut-out 50 x 25 mm [1.97 x 0.98"]
- Gasket
- Instruction manual, multilingual

¹⁾ Stock types

Hour meters / timers, electronic

LCD hour meters	Max. time range 99999 h 59 min or 99999.99 h	Codix 134
------------------------	---	------------------

Accessories	Dimensions in mm [inch]	Order no.
Adapter front bezel, 72 x 36 [2.83 x 1.42]	for cut-out 68 x 33 [2.68 x 1.30] to cut-out 45 x 22.2 [1.77 x 0.87], for counters 48 x 24 [1.89 x 0.94], as set	black and silver anodised 162704 Set
Adapter front bezel, 48 x 48 [1.89 x 1.89]	for cut-out 45 x 45 [1.77 x 1.77] to cut-out 45 x 22.2 [1.77 x 0.87], with clip mounting for counters 48 x 24 [1.89 x 0.94]	black T008883
Adapter front bezel, 60 x 50 [2.36 x 1.97]	for cut-out 54 x 29 [2.13 x 1.14] to cut-out 45 x 22.2 [1.77 x 0.87], with screw mounting and gasket for counters 48 x 24 [1.89 x 0.94]	black N003001
Transparent cover, lockable, IP65	for cut-out 54 x 29 [2.13 x 1.14], for screw mounting to front bezel F1B or adapter front bezel N003001, for counters with cut-out 50 x 25 [1.97 x 0.98] or 45 x 22.2 [1.77 x 0.87]	N003002
Sealing cover type K1, IP65	suitable for front bezel 60 x 50 [2.36 x 1.97], for screw mounting of electromech. counters and via adapter front bezel N003001 for counters 48 x 24 [1.89 x 0.94]	G008301
Mounting frame with cut-out 50 x 25 [2.36 x 1.97] via separate adapter also for 45 x 22.2 [1.77 x 0.87]	for snap-on mounting on 35 [1.38] top-hat DIN rail, for counters 53 x 28 [2.09 x 1.10] and via separate adapter (T008180) for counters 48 x 24 [1.89 x 0.94]	chromated G300004

Suitable gaskets, other accessories and installation examples for optional accessories can be found in chapter accessories or in the accessories section under: www.kuebler.com/accessories.

Technical data

General technical data	
Display	LCD, 7 digits, 8 mm [0.31"] high
Backlighting	external electrical source 24 V DC $\pm 20\%$, 50 mA
Modes	adding
Display range	see next page
Reset	manual and electrical
Working temperature	-10°C ... +55°C [+14°F ... +131°F] (non-condensing)
Operating temperature	-10°C ... +60°C [+14°F ... +140°F] (non-condensing)
Storage temperature	-20°C ... +70°C [-4°F ... +158°F]
Altitude	up to 2000 m [6562']

Electrical characteristics	
Power supply	internal lithium battery approx. 8 years at 20°C [68°F]
EMC standards	EN 55011 class B EN 61000-6-2, EN 61000-6-3
Device safety	designed to protection class application area EN 61010 part 1 2 pollution level 2
UL approval	file E128604
Measuring error	per Start/Stop cycle a maximum error in the order of the smallest measuring time selected can occur

Mechanical characteristics	
Housing	dark grey RAL 7021
Protection	IP65 (front side)
Weight	approx. 50 g [1.76 oz]

Count input	
A. Timer inputs DC versions (max. 30 V DC) INP B	
Timer input	NPN or PNP depending on the type (see table)
Switching level	NPN LOW: 0 ... 0.7 V DC HIGH: 3 ... 30 V DC PNP LOW: 0 ... 0.7 V DC HIGH: 4 ... 30 V DC
Counting start	NPN for LOW signal at the timer input PNP for HIGH signal at the timer input
B. Timer inputs high voltage versions (10 ... 260 V DC/V AC) INP A	
Timer input	optocoupler input
Min. pulse time	16 ms
Switching level	LOW: 0 ... 2 V DC/V AC HIGH: 10 ... 260 V DC/V AC
Counting start	for HIGH signal at the timer input
C. Time range change (Mode)	
Contact input	open collector (switching at 0 V) NPN LOW 0 ... 0.7 V DC HIGH 3 ... 5 V DC
Time range	depending on the circuit (s. order inform.)
D. Reset input for DC (reset) and High voltage (INPB)	
Min. pulse time	DC 50 ms High voltage 16 ms
Contact input DC	NPN LOW 0 ... 0.7 V DC HIGH 3 ... 30 V DC
High voltage input	10 ... 260 V AC/DC
E. Reset locking input (for DC and AC)	
Electrical reset key locking	
Input not active	reset key locked
Contact input	open collector NPN (switching at 0 V)
Switching level	NPN LOW 0 ... 0.7 V DC HIGH 3 ... 5 V DC

Hour meters / timers, electronic

LCD hour meters

Max. time range 99999 h 59 min or 99999.99 h

Codix 134

Terminal assignment

DC type: 6.134.012.8x0

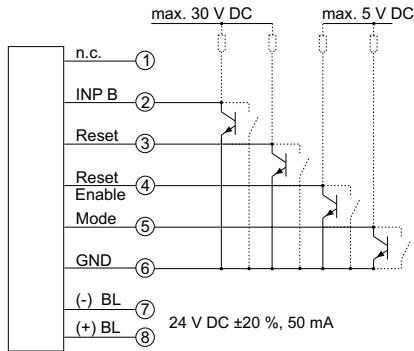

DC type: 6.134.012.8x1

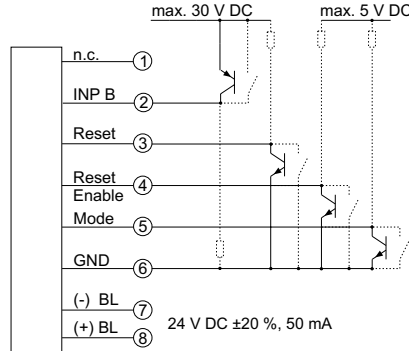

AC type: 6.134.012.8x3

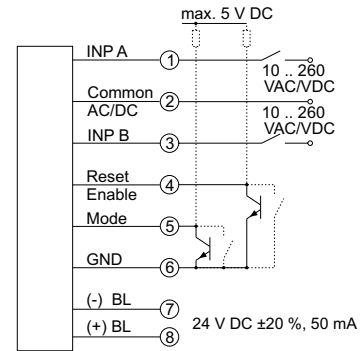

BL = backlighting

Display and time ranges

time range	display
99999 h 59 m	99999 - 59
99999.99 h	99999 - 99

Dimensions

Dimensions in mm [inch]

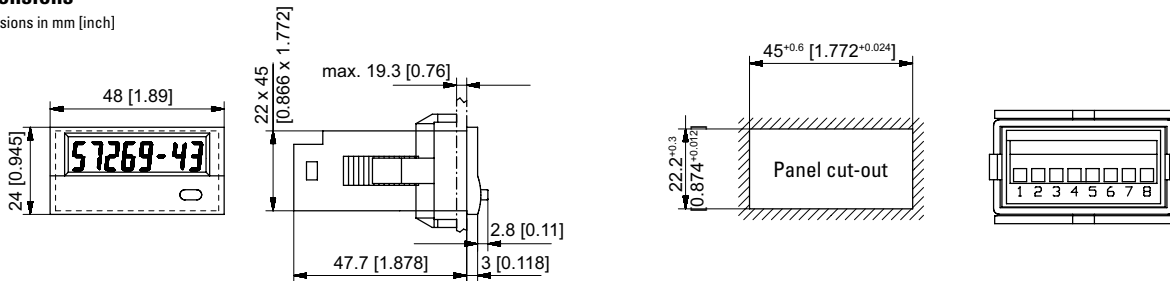

Front bezel for clip mounting (included in delivery)

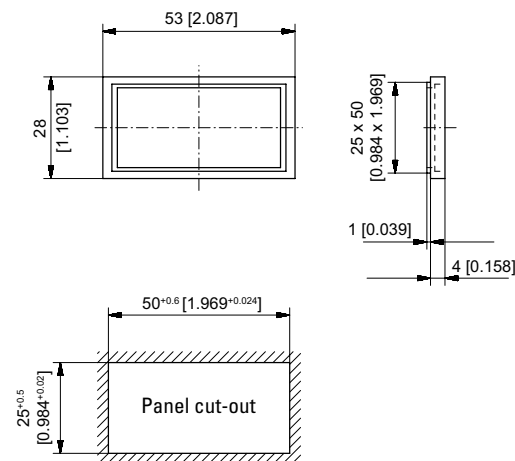

Front bezel for screw mounting (included in delivery)

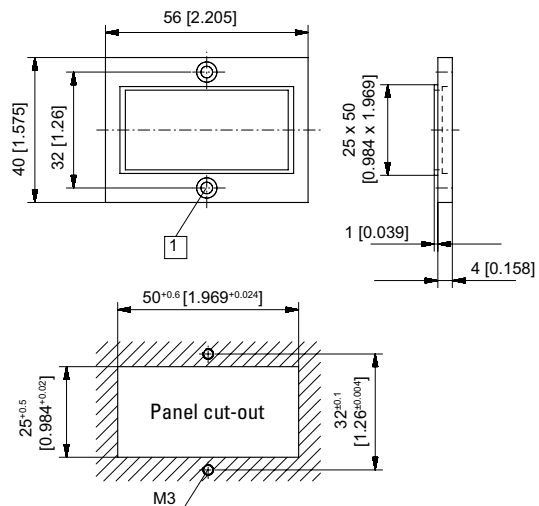

1 Countersinking Af3, DIN 74

LCD hour meters	Max. time range 9999 h 59 min 59 sec or 9999999.9 sec	Codix 135
------------------------	--	------------------



The Codix 135 is a simple battery-powered hour meter for PNP, NPN and high-voltage applications.

Its 8-digit LCD display with optional backlighting can display various time ranges.



Battery powered	Timer	Input type	Pulse voltage 4 ... 30 V	Pulse voltage 10 ... 260 V	Temperature range - 10° + 60°	High protection level IP65	DIN front bezel DIN 48 x 24	LCD display 8 LCDs	Lockable reset

Powerful

- High quality LCD display with 8 mm high figures - optional display backlighting.
- Time range up to 9999999.9 seconds or 9999h99m99s programmable via control input.
- Battery lifetime 8 years.
- High voltage versions for 10 ... 260 V AC/DC voltage pulses, thus to be connected directly via contactors, relays and motors.
- Very high accuracy: 100 ppm.

Simple

- Screw terminals, RM 5 mm.
- Reset key lockable via the input 'Reset Enable'.
- According to version for PNP, NPN switching level or high voltage version for 10 ... 260 V AC/DC switching voltage.
- Accumulated time is always readable thanks to battery powering.
- High protection level IP65.

Order code

6.135 . 012 . 8XX
a b

a Backlighting

- 5 = without ¹⁾
- 6 = with

b Input type: measurement of short times

Input type	INP A		INP B	
0 = adding ¹⁾	-		0 ... 0.7 V DC	NPN
1 = adding ¹⁾	-		4 ... 30 V DC	PNP
3 = adding ¹⁾	10 ... 260 V AC/DC	AC/DC	10 ... 260 V AC/DC	AC/DC

Delivery specification

- Timer
- Mounting clip
- Front bezel for screw mounting (T008181) 56 x 40 mm [2.20 x 1.57"], panel cut-out 50 x 25 mm [1.97 x 0.98"]
- Front bezel for clip mounting (T008180) 53 x 28 mm [2.09 x 1.10"], panel cut-out 50 x 25 mm [1.97 x 0.98"]
- Gasket
- Instruction manual, multilingual

1) Stock types

Hour meters / timers, electronic

LCD hour meters	Max. time range 9999 h 59 min 59 sec or 9999999.9 sec	Codix 135
------------------------	--	------------------

Accessories	Dimensions in mm [inch]	Order no.
Adapter front bezel, 72 x 36 [2.83 x 1.42]	For cut-out 68 x 33 [2.68 x 1.30] to cut-out 45 x 22.2 [1.77 x 0.87], for counters 48 x 24 [1.89 x 0.94], as set black and silver anodised	162704 Set
Adapter front bezel, 48 x 48 [1.89 x 1.89]	For cut-out 45 x 45 [1.77 x 1.77] to cut-out 45 x 22.2 [1.77 x 0.87], with clip mounting for counters 48 x 24 [1.89 x 0.94] black	T008883
Adapter front bezel, 60 x 50 [2.36 x 1.97]	For cut-out 54 x 29 [2.13 x 1.14] to cut-out 45 x 22.2 [1.77 x 0.87], with screw mounting and gasket for counters 48 x 24 [1.89 x 0.94] black	N003001
Transparent cover, lockable, IP65	For cut-out 54 x 29 [2.13 x 1.14], for screw mounting to front bezel F1B or adapter front bezel N003001, for counters with cut-out 50 x 25 [1.97 x 0.98] or 45 x 22.2 [1.77 x 0.87]	N003002
Sealing cover type K1, IP65	Suitable for front bezel 60 x 50 [2.36 x 1.97], for screw mounting of electromech. counters and via adapter front bezel N003001 for counters 48 x 24 [1.89 x 0.94]	G008301
Mounting frame with cut-out 50 x 25 [2.36 x 1.97] via separate adapter also for 45 x 22.2 [1.77 x 0.87]	For snap-on mounting on 35 [1.38] top-hat DIN rail, for counters 53 x 28 [2.09 x 1.10] and via separate adapter (T008180) for counters 48 x 24 [1.89 x 0.94] chromated	G300004

Suitable gaskets, other accessories and installation examples for optional accessories can be found in chapter accessories or in the accessories section under: www.kuebler.com/accessories.

Technical data

General technical data	
Display	LCD, 8-digits, 8 mm [0.31"] high
Backlighting	external electrical source 24 V DC $\pm 20\%$, 50 mA
Counting direction	adding
Display range	see next page
Reset	manual and electrical
Working temperature	-10°C ... +55°C [+14°F ... +131°F] (non-condensing)
Operating temperature	-10°C ... +60°C [+14°F ... +140°F] (non-condensing)
Storage temperature	-20°C ... +70°C [-4°F ... +158°F]
Altitude	up to 2000 m

Electrical characteristics	
Power supply	internal lithium battery approx. 8 years at 20°C [68°F]
EMC standards	EN 55011 class B EN 61000-6-2, EN 61000-6-3
Device safety	Designed to EN 61010 part 1 Protection class 2 Application area pollution level 2
UL approval	file E128604

Mechanical characteristics	
Housing	dark grey RAL 7021
Protection	IP65 (front side)
Weight	approx. 50 g [1.76 oz]

Count input		
A. Timer inputs DC versions (max. 30 V DC) INP B		
Timer input	NPN or PNP	depending on the type (see table)
Switching level	NPN	LOW: 0 ... 0.7 V DC HIGH: 3 ... 30 V DC
	PNP	LOW: 0 ... 0.7 V DC HIGH: 4 ... 30 V DC
Counting start	NPN	for LOW signal at the timer input
	PNP	for HIGH signal at the timer input
B. Timer inputs high voltage versions (10 ... 260 V DC/V AC) INP A		
Timer input		optocoupler input
Min. pulse time		16 ms
Switching level		LOW: 0 ... 2 V DC/V AC HIGH: 10 ... 260 V DC/V AC
Counting start		for HIGH signal at the timer input
C. Time range change (Mode)		
Contact input	NPN	open collector (switching at 0 V) LOW 0 ... 0.7 V DC HIGH 3 ... 5 V DC
Time range		depending on the circuit (s. order inform.)
D. Reset input for DC and high voltage		
Min. pulse time	DC	50 ms
	High voltage	16 ms
Contact input DC	NPN	LOW 0 ... 0.7 V DC HIGH 3 ... 30 V DC
High voltage input		10 ... 260 V AC/DC
E. Reset locking input (for DC and AC)		
Electrical reset key locking		
Input not active		reset key locked
Contact input		open collector NPN (switching at 0 V)
Switching level	NPN	LOW 0 ... 0.7 V DC HIGH 3 ... 5 V DC

Product overview
Basics
Pulse counters
Preset counters
Hour meters
Timers
Frequency displays
Tachometers
Position displays
Multifunction devices
Energy meters
Process devices
Temperature devices
Strain-gauge controllers
Accessories
Index

Hour meters / timers, electronic

LCD hour meters	Max. time range 9999 h 59 min 59 sec or 9999999.9 sec	Codix 135
------------------------	--	------------------

Terminal assignment

DC type: 6.135.012.8x0

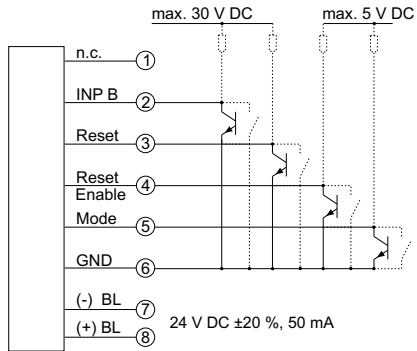

DC type: 6.135.012.8x1

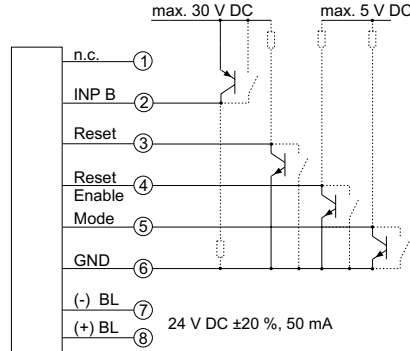

AC type: 6.135.012.8x3

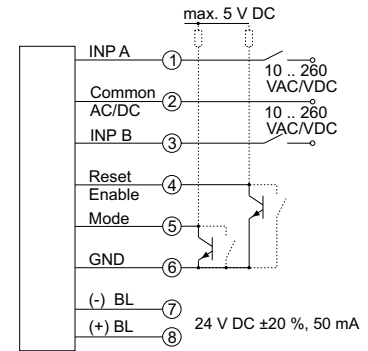

BL = backlighting

Display and time ranges

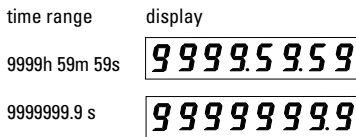

Dimensions

Dimensions in mm [inch]

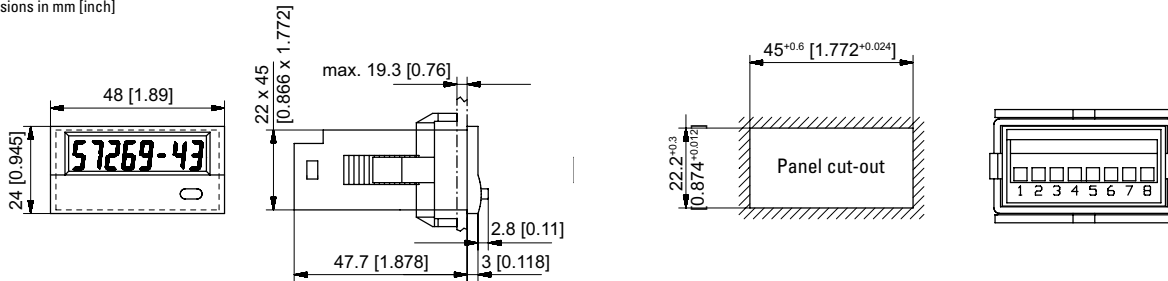

Front bezel for clip mounting (included in delivery)

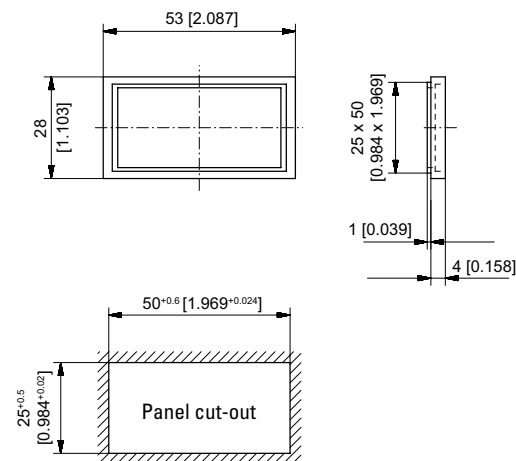

Front bezel for screw mounting (included in delivery)

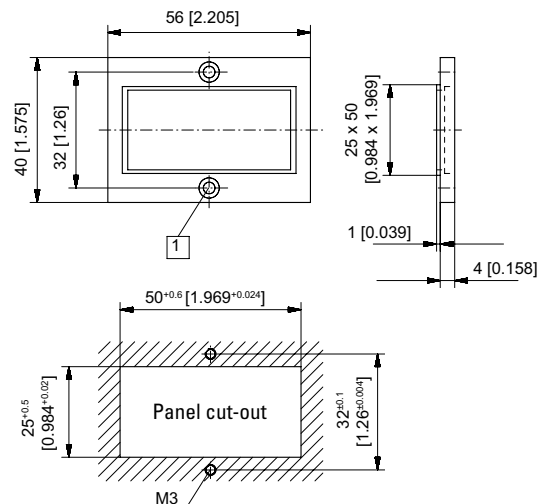

1 Countersinking Af3, DIN 74

Product overview Basics
Pulse counters
Preset counters
Hour meters Timers
Frequency displays Tachometers
Position displays
Multifunction devices
Energy meters
Process devices
Temperature devices
Strain-gauge controllers
Accessories Index

Hour meters / timers, electronic

LCD hour meters

Adding counter / service timer, 99999.99 h (DC)

Codix 141 / 143



The Codix 141 / 143 is a simple externally powered hour meter with 7-digit LCD display for PNP, NPN input signals, optionally factory-programmable.

Codix 141: Standard timer
Codix 143: Service timer



DC 10 ... 30V	PNP/NPN	Timer	-20° + 65°	IP65	DIN 48 x 24	7 LCDs	Lockable reset	Transistor output (143)
Power supply	Input type	Timer	Temperature range	High protection level	DIN front bezel	LCD display	Lockable reset	Transistor output (143)

Functional

- Direct display of the total time.
- Pressing the key displays the preset service value and its pre-signal.
- Preset value output as a text on the display and on the transistor output.
- Pre-signal for the service intervals as a text on the display.
- Manual or electrical reset of the display or of the service intervals.
- Fast PNP or damped NPN control via separate inputs.

User-friendly

- Power supply 10 ... 30 V DC.
- Values stored in EEPROM.
- Fixed pre-programmed service intervals, e.g.: service at 5000.00 h (service), pre-signal at 4900.00 h (pre-service), blinking text message on the display (service or pre-service).
- Multifunction reset key, lockable via a separate input.
- Can also be reset to its delivery condition.
- Factory programmable.

Order code
Standard timer 6.141 . 012 . 300

Stock types:
 6.141.012.300

Order code
Service timer 6.143 . 011 . 300 . **XXXX** . **XX**

Stock types:
 6.143.011.300.005K.00

a Option 2¹⁾
005K = Service range 5000.00 h

b Option 1¹⁾
00 = Pre-warning at 100.00 before the preset service value
 Display shows text PrESErV with pre-warning and text SErVICE with preset service value

Delivery specification Codix 141 and 143

- Counter
- Mounting clip
- Gasket
- Instruction manual, multilingual

1) Options 1 and 2 can be individually programmed at the factory according to customer's requirements. Please note: The min. order quantity for custom versions is 10 pcs. with an extra charge, or 200+ pcs. with no extra charge.

Hour meters / timers, electronic

LCD hour meters	Adding counter / service timer, 99999.99 h (DC)		Codix 141 / 143
Accessories	Dimensions in mm [inch]		Order no.
Adapter front bezel, 53 x 28 [2.09 x 1.10]	For cut-out 50 x 25 [1.97 x 0.98] to cut-out 45 x 22.2 [1.77 x 0.87], with clip mounting for counters 48 x 24 [1.89 x 0.94]	anthracite	T008180
Adapter front bezel, 56 x 40 [2.20 x 1.57]	For cut-out 50 x 25 [1.97 x 0.98] to cut-out 45 x 22.2 [1.77 x 0.87], with screw mounting for counters 48 x 24 [1.89 x 0.94]	anthracite	T008181
Adapter front bezel, 72 x 36 [2.83 x 1.42]	For cut-out 68 x 33 [2.68 x 1.30] to cut-out 45 x 22.2 [1.77 x 0.87], for counters 48 x 24 [1.89 x 0.94], as set	black and silver anodised	162704 Set
Adapter front bezel, 48 x 48 [1.89 x 1.89]	For cut-out 45 x 45 [1.77 x 1.77] to cut-out 45 x 22.2 [1.77 x 0.87], with clip mounting for counters 48 x 24 [1.89 x 0.94]	black	T008883
Adapter front bezel, 60 x 50 [2.36 x 1.97]	For cut-out 54 x 29 [2.13 x 1.14] to cut-out 45 x 22.2 [1.77 x 0.87], with screw mounting and gasket for counters 48 x 24 [1.89 x 0.94]	black	N003001
Transparent cover, lockable, IP65	For cut-out 54 x 29 [2.13 x 1.14], for screw mounting to front bezel F1B or adapter front bezel N003001, for counters with cut-out 50 x 25 [1.97 x 0.98] or 45 x 22.2 [1.77 x 0.87]		N003002
Sealing cover type K1, IP65	Suitable for front bezel 60 x 50 [2.36 x 1.97], for screw mounting of electromech. counters and via adapter front bezel N003001 for counters 48 x 24 [1.89 x 0.94]		G008301
Mounting frame with cut-out 50 x 25 [2.36 x 1.97] via separate adapter also for 45 x 22.2 [1.77 x 0.87]	For snap-on mounting on 35 [1.38] top-hat DIN rail, for counters 53 x 28 [2.09 x 1.10] and via separate adapter (T008180) for counters 48 x 24 [1.89 x 0.94]	chromated	G300004

Suitable gaskets, other accessories and installation examples for optional accessories can be found in chapter accessories or in the accessories section under: www.kuebler.com/accessories.

Technical data	
General technical data	
Display	LCD, 7 digits, 8 mm [0.31"] high
Undervoltage	display for $U_B < 8$ V: PO-FAIL and data backup
Counting range	0 ... 99999.99 h decimal point 0.00
Data backup	EEPROM
Operating temperature	-20°C ... +65°C [-4°F ... +149°F] (non-condensing)
Storage temperature	-25°C ... +75°C [-13°F ... +167°F]
Mechanical characteristics	
Housing	front panel mount, DIN 43700 48 x 24 mm [1.89 x 0.94"] dark grey Ral 7021
Connections	8-pole screw terminals, pitch 5.08 mm [2.00"]
Cleaning	the front side should be cleaned using only a soft cloth moistened with water
Weight	40 g [1.41 oz]
Protection	IP65 (front side) IP20 (rear side)
Vibration resistance acc. to EN 60068-2-6	10 ... 55 Hz / 1 mm [0.04"] / 30 min
Shock resistance acc. to EN 60068-2-27	100 G: 2 ms 10 G: 6 ms
Electrical characteristics	
Power supply	10 ... 30 V DC, max. 25 mA
Start delay	500 ms
EMC standards	EN 55011 class B, EN 61000-6-2, EN 61000-6-3 EN 61326-1
Inputs	
Input A	static PNP input
Input B	static NPN input
Reset key enable input	static NPN input
Reset	edge-triggered NPN input (min. 20 ms)
Input resistance	10 kOhm
Switching level	LOW 0 ... 2 V DC HIGH 3.5 ... 30 V DC
Switching threshold	approx. 2.7 V DC
Additional data for Codix 143 (service timer)	
Output	NPN transistor output, open collector
Output voltage	max. 30 V DC
Output current	max. 50 mA

Hour meters / timers, electronic

LCD hour meters Adding counter / service timer, 99999.99 h (DC) Codix 141 / 143

Display and inquiry mode service timer

If the reset key is not released by means of the activation input of pin 6, pressing the key makes the following functions available to the user.

Press 1x: The text "SErVICE" is displayed

Press 2x: The following service value is displayed

Press 3x: The text „PRESErV" is displayed

Press 4x: The following preservice value is displayed

Press 5x: The current value is displayed

For the service timers, the values counted remain stored, the service values are incremented by the stored preset value when resetting. E.g. service value 5000.00 h, counter count when resetting 5100.00 h, new service value 10100.00 h.

Applications

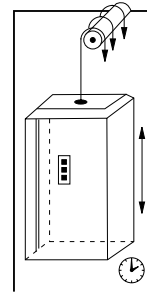

Operating time and service interval

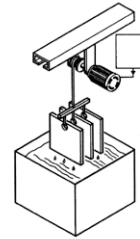

Total time and service interval

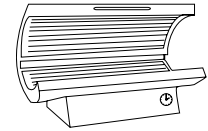

Service interval and total time of the UV lamps

Terminal assignment

PIN	Description	Standard timer	Service timer
Power supply			
1	+U _B	10 ... 30 V DC	10 ... 30 V DC
2	0 V DC, GND	GND	GND
Inputs			
3	0 V DC, GND	GND	GND
4	Fast counting input	INP PNP	INP PNP
5	Slow counting input	INP NPN	INP NPN
6	Reset enable input	RESET MANUAL ENABLE	RESET MANUAL ENABLE
7	Reset input	RESET	RESET
Output			
8	NPN output	n.c.	OUT

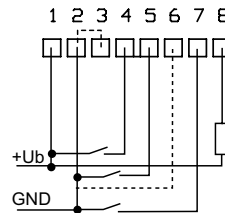

Output 8 is only used with Codix 143 as a NPN output

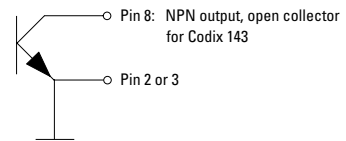

Dimensions

Dimensions in mm [inch]

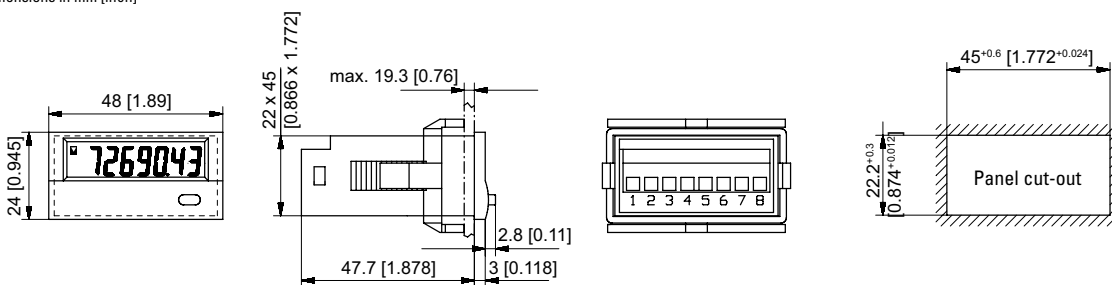

LED timers	h, min, sec or hh.mm.ss (DC)	Codix 523
-------------------	-------------------------------------	------------------



The Codix 523 is an externally powered timer, hour meter or short-time meter with 4 start input types and individually adjustable time base.

The 6-digit LED display shows the NPN, PNP input signals used for pulse width or time interval measurement.



Product overview
Basics
Pulse counters
Preset counters
Hour meters
Timers
Frequency displays
Tachometers
Position displays
Multifunction devices
Energy meters
Process devices
Temperature devices
Strain-gauge controllers
Accessories
Index

DC 10 ... 30 V Power supply	000000 DIN 48 x 24 DIN front bezel	-20° + 65° Temperature range	IP65 High protection level	Prog Menu-driven programming	Timer	≥ 1 ms Resolution
--	---	--	--------------------------------------	--	--------------	-----------------------------

Powerful

- High accuracy thanks to quartz time base.
- Robust housing – IP65 protected.
- Very bright LED display, 8 mm high.
- Time base can be set individually
 - hours, minutes or seconds, the decimal point allows setting it even more accurately, up to max. 3 decimal places.
 - smallest achievable resolution: milliseconds.
 - time base hours (minutes and seconds as real-time display).
- Short start-up time – detects incoming pulses already 16 ms after having been switched on => no loss of pulses in case of a simultaneous motor start.
- Individually adjustable Start/Stop function
2 Start/Stop inputs allow achieving 4 different measuring principles such as, for example, active or passive pulse width measurement, time interval measurement with one single input or with separate inputs.

User-friendly and universal

- Large keys – pressing either of the keys switches between displays (can also be operated wearing gloves).
- Programming
 - simple uniform menu-driven programming and operation.
 - possibility to enter the programming mode also during operation with an authentication query.
- Manual or electrical reset
Tamper-proof thanks to lockable reset function.
- Freely programmable setpoint
Start time at which time counting begins.
- As an alternative to the HTL inputs, devices with a 4 ... 30 V DC input level are available, for use as parallel displays for PLCs.
- Optional output: 1 Hz clock pulse in case of active time measurement.

Order code

6.523 . 01 X . 3 X 0

- | | |
|-----------------------------|----------------------------------|
| a Output | b Input switch level |
| 1 = Optocoupler | 0 = Standard (HTL) ¹⁾ |
| 2 = No output ¹⁾ | A = 4 ... 30 V DC |

Delivery specification

- Timer
- Mounting clip
- Gasket
- Instruction manual, multilingual
- Front bezel for screw mounting (T008181) 56 x 40 mm [2.20 x 1.57"], panel cut-out 50 x 25 mm [1.97 x 0.98"]
- Front bezel for clip mounting (T008180) 53 x 28 mm [2.09 x 1.10"], panel cut-out 50 x 25 mm [1.97 x 0.98"]

1) Stock types

Hour meters / timers, electronic

LED timers	h, min, sec or hh.mm.ss (DC)	Codix 523
Accessories	Dimensions in mm [inch]	Order no.
Adapter front bezel, 72 x 36 [2.83 x 1.42]	For cut-out 68 x 33 [2.68 x 1.30] to cut-out 45 x 22.2 [1.77 x 0.87], for counters 48 x 24 [1.89 x 0.94], as set black and silver anodised	162704 Set
Adapter front bezel, 48 x 48 [1.89 x 1.89]	For cut-out 45 x 45 [1.77 x 1.77] to cut-out 45 x 22.2 [1.77 x 0.87], with clip mounting for counters 48 x 24 [1.89 x 0.94]	black T008883
Adapter front bezel, 60 x 50 [2.36 x 1.97]	For cut-out 54 x 29 [2.13 x 1.14] to cut-out 45 x 22.2 [1.77 x 0.87], with screw mounting and gasket for counters 48 x 24 [1.89 x 0.94]	black N003001
Transparent cover, lockable, IP65	For cut-out 54 x 29 [2.13 x 1.14], for screw mounting to front bezel F1B or adapter front bezel N003001, for counters with cut-out 50 x 25 [1.97 x 0.98] or 45 x 22.2 [1.77 x 0.87]	N003002
Sealing cover type K1, IP65	Suitable for front bezel 60 x 50 [2.36 x 1.97], for screw mounting of electromech. counters and via adapter front bezel N003001 for counters 48 x 24 [1.89 x 0.94]	G008301
Mounting frame with cut-out 50 x 25 [2.36 x 1.97] via separate adapter also for 45 x 22.2 [1.77 x 0.87]	For snap-on mounting on 35 [1.38] top-hat DIN rail, for counters 53 x 28 [2.09 x 1.10] and via separate adapter (T008180) for counters 48 x 24 [1.89 x 0.94]	chromated G300004

Suitable gaskets, other accessories and installation examples for optional accessories can be found in chapter accessories or in the accessories section under: www.kuebler.com/accessories.

Technical data

General technical data	
Display	6 digits, red 7 segment LED display; 8 mm [0.31"] high
Data backup	EEPROM
Operating temperature	10 ... 26 V DC -20°C ... +65°C [-4°F ... +149°F] > 26 ... 30 V DC -20°C ... +55°C [-4°F ... +131°F] (non-condensing)
Storage temperature	-25°C ... +70°C [-13°F ... +158°F]

Mechanical characteristics	
Housing	front panel mount 48 x 24 mm [1.89 x 0.94"] acc. to DIN 43700; RAL 7021, dark grey
Protection	IP65 (front side)
Weight	approx. 50 g [1.76 oz]
Vibration resistance acc. to EN 60068-2-6	10 ... 55 Hz / 1 mm [0.04"] / 30 min
Shock resistance acc. to EN 60068-2-27	100 G: 2 ms 10 G: 6 ms

Outputs (optional)	
Output power optocoupler	max. 30 V, 10 mA

Electrical characteristics	
Power supply	10...30 V DC, with integrated reverse polarity protection
Current consumption	max. 55 mA
EMC standards	EN 55011 class B, EN 61000-6-2, EN 61000-6-3 EN 61326-1
UL-Zulassung	File E128604

Inputs	
Polarity of inputs	programmable, NPN or PNP for all inputs
Input resistance	approx. 5 kΩ
Resolution	up to 0.001 s
Minimum pulse duration of the reset input	5 ms
Input switching level standard version (HTL)	LOW 0 ... 0.2 x U _B [V DC] HIGH 0.6 x U _B ... 30 V DC
Input switching level at 4 ... 30 V DC	LOW 0 ... 2 V DC HIGH 4 ... 30 V DC
Accuracy	< 50 ppm

Applications for time and hour meters, short-time meters

- Time measurements such as hours run recording on all machines and plant, e.g. compressors, solariums, special lights and lamps
- Accessories, OEM equipment or retrofitting to production machine
- Measurement of short times on processes and procedures, time recording (stopwatch function) at sporting events
- Hours run recording for motor vehicles and time monitoring for rally vehicles

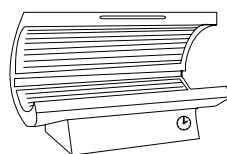

Hours run of UV lamps

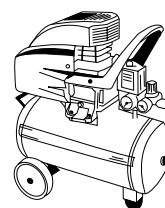

Operating hours

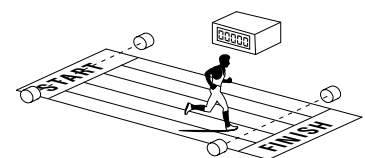

Short time measurement > 1 ms

Hour meters / timers, electronic

LED timers	h, min, sec or hh.mm.ss (DC)	Codix 523
-------------------	-------------------------------------	------------------

Block diagram

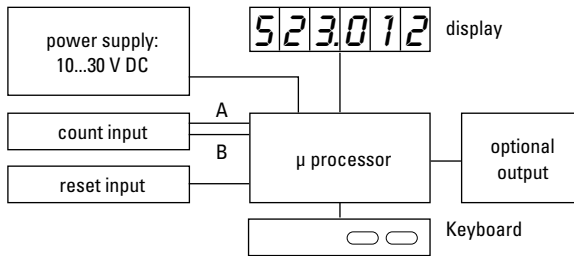

Terminal assignment

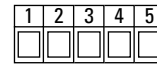

PIN	without optocoupler
1	10 ... 30 V DC
2	0 V GND
3	INP A
4	INP B
5	reset

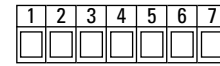

PIN	with optocoupler (NPN)
1	10 ... 30 V DC
2	0 V GND
3	INP A
4	INP B
5	reset
6	emitter
7	collector

Dimensions

Dimensions in mm [inch]

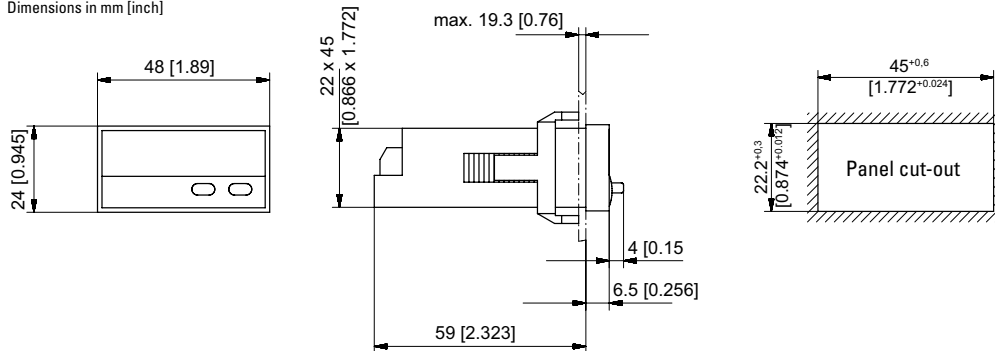

Front bezel for clip mounting (included in delivery)

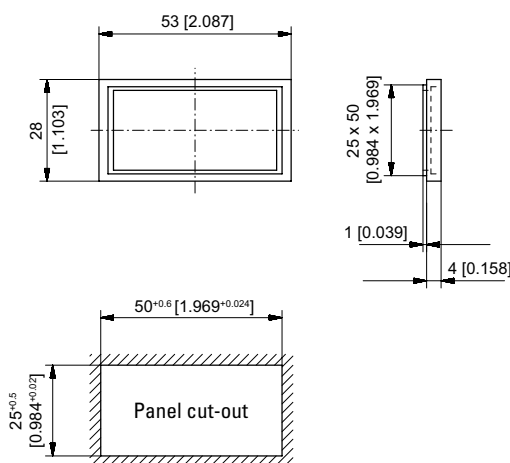

Front bezel for screw mounting (included in delivery)

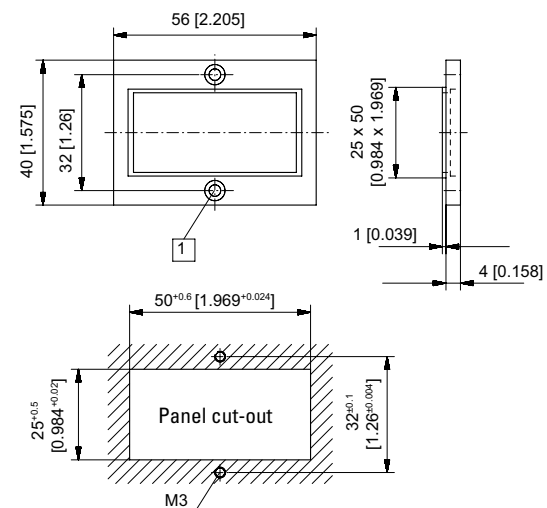

1 Countersinking Af3, DIN 74

Product overview Basics
Pulse counters
Preset counters
Hour meters Timers
Frequency displays Tachometers
Position displays
Multifunction devices
Energy meters
Process devices
Temperature devices
Strain-gauge controllers
Accessories Index

LED timers

h, min, sec or hh.mm.ss (AC+DC)

Codix 543



The Codix 543 is an externally powered timer, hour meter or short-time meter with 4 start input types and individually adjustable time base.

The 6-digit LED display shows the NPN, PNP input signals used for pulse width or time interval measurement.



DC 10 ... 30V	AC 100 ... 240V	000000 DIN 96 x 48	-20° + 65° Temperature range	IP65 High protection level	Plug-in screw terminal	Prog Menu-driven programming	Timer	≥ 1 ms Resolution
-------------------------	---------------------------	------------------------------	--	--------------------------------------	-------------------------------	--	--------------	-----------------------------

Powerful

- High accuracy thanks to quartz time base.
- Robust housing – IP65 protection.
- Very bright LED display 14 mm high.
- Time base can be set individually
 - hours, minutes or seconds, the decimal point allows setting it even more accurately, up to max. 3 decimal places.
 - smallest achievable resolution: milliseconds.
 - time base hours (minutes and seconds as real-time display).
- Short start-up time – detects incoming pulses already 16 ms after having been switched on => no loss of pulses in case of a simultaneous motor start.
- Individually adjustable Start/Stop function
 - 2 Start/Stop inputs allow achieving 4 different measuring principles such as, for example, active or passive pulse width measurement, time interval measurement with one single input or with separate inputs.

User-friendly and universal

- Large keys – pressing either of the keys switches between displays (utilisable même avec des gants).
- Programming
 - Simple and unified programming and operation thanks to menu-driven programming.
 - possibility to enter the programming mode also during operation with an authentication query.
- Manual or electrical reset
 - Tamper-proof thanks to lockable reset function.
- Freely programmable setpoint
 - Start time at which time counting begins.
- AC or DC power supply with sensor power supply.
- As an alternative to the HTL inputs, devices with a 5 V DC input level are available, for use as parallel displays for PLCs.
- Optional output: 1 Hz clock pulse in case of active time measurement.

Order code

6.543 . 01 X . XX 0

a Output

- 1 = Optocoupler
- 2 = No output ¹⁾

c Input switch level

- 0 = Standard (HTL) ¹⁾
- A = 4 ... 30 V DC

Delivery specification

- Digital display
- Mounting clip
- Gasket
- 2 screw terminals
- Instruction manual, multilingual

Replacement parts

- 7 pin screw terminal RM 3.81 1 ... 7: N100387
- 2 pin screw terminal RM 5.08 1 ... 2: N100133

b Power supply

- 0 = 100 ... 240 V AC, ±10 % ¹⁾
- 3 = 10 ... 30 V DC ¹⁾

Accessories

Dimensions in mm [inch]

Order no.

Mounting frame

with cut-out 92 x 45 [3.62 x 1.77]

for snap-on mounting on 35 [1.38] top-hat DIN rail,
for counters 96 x 48 [3.74 x 1.89]

grey

G300005

Suitable gaskets as well as further accessories can be found in the accessories section or in the accessories area of our website at: www.kuebler.com/accessories.

1) Stock types

Product overview
Basics

Pulse counters

Preset counters

Hour meters
Timers

Frequency displays
Tachometers

Position displays

Multifunction
devices

Energy meters

Process devices

Temperature
devices

Strain-gauge
controllers

Accessories
Index

Hour meters / timers, electronic

LED timers	h, min, sec or hh.mm.ss (AC+DC)	Codix 543
-------------------	--	------------------

Technical data

General technical data	
Display	6 digit, red 7 segment LED display; 14 mm [0.55"] high
Data backup	EEPROM
Operating temperature	-20°C ... +60°C [-4°F ... +140°F] (non-condensing)
Storage temperature	-20°C ... +70°C [-4°F ... +158°F]
Altitude	up to 2000 m [6562']

Electrical characteristics	
Power supply	10 ... 30 VDC, with reverse polarity protection 100 ... 240 V AC, ±10 %
Current consumption	max. 50 mA, 6 VA
EMC standards	EN 55011 class B, EN 61000-6-2, EN 61000-6-3
Device safety	designed to protection class 2 application area EN 61010 part 1 pollution level 2

Mechanical characteristics	
Housing	front panel mount 96 x 48 mm [3.74 x 1.89"] acc. to DIN 43700; RAL 7021, dark grey
Protection	IP65 (front side)
Weight	approx. 150 g [5.29 oz]

Inputs	
Polarity of inputs	programmable, NPN or PNP for all inputs
Input resistance	approx. 5 kΩ
Resolution	up to 0.001 s
Minimum pulse duration of the reset input	5 ms
Input switching level standard version (HTL)	
DC power supply	LOW 0 ... 0.2 x U _B [V DC] HIGH 0.6 x U _B ... 30 V DC
AC power supply	LOW 0 ... 4 V DC HIGH 12 ... 30 V DC
Input switching level at 4 ... 30 V DC	LOW 0 ... 2 V DC HIGH 4 ... 30 V DC
Accuracy	< 50 ppm

Outputs	
Sensors power supply (AC version)	24 V DC ±15 %/100 mA
Output power optocoupler	max. 30 V DC, 10 mA

Applications for time and hour meters, short-time meters

- Time measurements such as hours run recording on all machines and plant, e.g. compressors, solariums, special lights and lamps
- Accessories, OEM equipment or retrofitting to production machine
- Measurement of short times on processes and procedures, time recording (stopwatch function) at sporting events
- Hours run recording for motor vehicles and time monitoring for rally vehicles

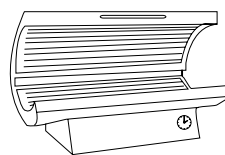

Hours run of UV lamps

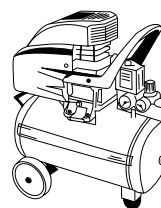

Operating hours

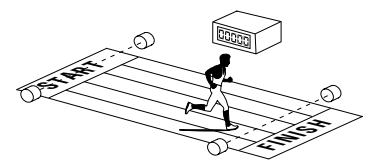

Short time measurement > 1 ms

Block diagram

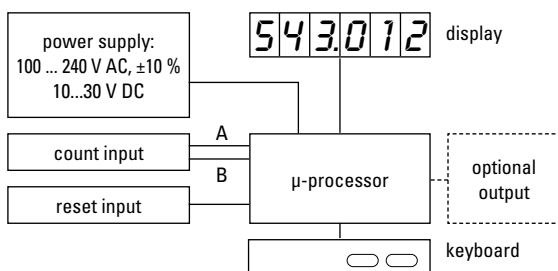

Hour meters / timers, electronic

LED timers	h, min, sec or hh.mm.ss (AC+DC)	Codix 543
-------------------	--	------------------

Terminal assignment

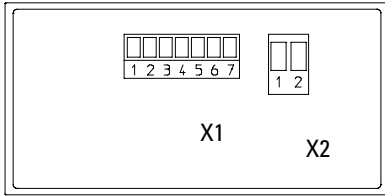

Connection X1

PIN	AC version	DC version
1	Optocoupler output	emitter
2	Optocoupler output	collector
3	Reset	
4	INP B	
5	INP A	
6	GND out	n.c.
7	+24 V out	n.c.

Connection X2

PIN	AC version	DC version
1	100 ... 240 V AC, ±10 %	0 V DC (GND)
2	100 ... 240 V AC, ±10 %	10 ... 30 V DC

Dimensions

Dimensions in mm [inch]

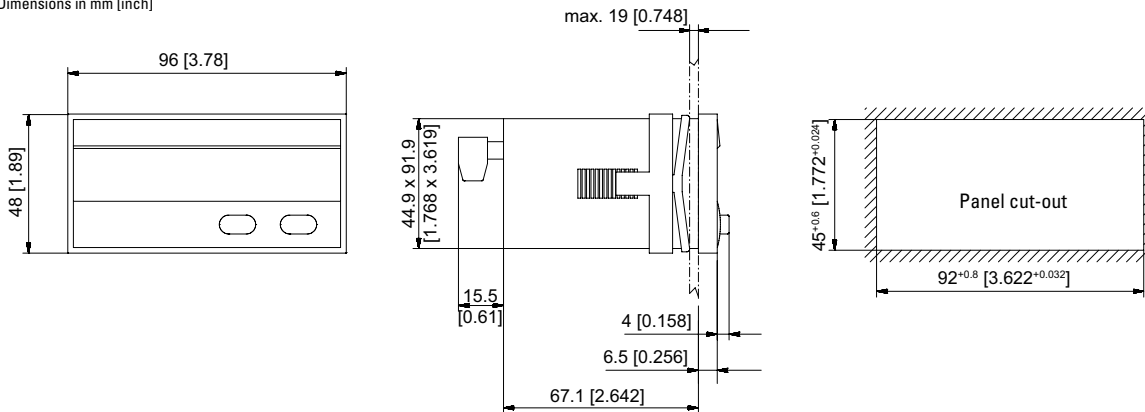

Product overview
Basics

Pulse counters

Preset counters

Hour meters
Timers

Frequency displays
Tachometers

Position displays

Multifunction
devices

Energy meters

Process devices

Temperature
devices

Strain-gauge
controllers

Accessories
Index

Hour meters / timers, electronic

LCD time modules	Max. time range 9999.99 h (DC)	194
-------------------------	---------------------------------------	------------



The timer module of the type 194 for PCB mount features a 6-digit LCD display and 2 voltage ranges (4.75...15 V DC and 9...60 V DC).

It is extremely robust and suitable for many different applications thanks to its wide temperature range.



Timer	DC 4.75...60V Power supply	PNP Input type	High shock resistance	-40° + 80° Temperature range	PCB mount	6 LCDs LCD display	Electrical reset
-------	---	-------------------	-----------------------	---------------------------------	-----------	-----------------------	------------------

Powerful

- Display range up to 9999-99 hours.
- 6-digit LCD display, 6 mm high.
- Low power consumption.
- Wide voltage and temperature range.
- Very high shock and vibration resistance.

Simple

- Non-volatile memory (no battery).
- Counting starts as soon as power supply is applied.
- Electrical reset.
- Very high reliability.
- Small size and low cost.

Order specifications			
<i>Power supply</i>	<i>Order no.</i>	<i>Art.-No.</i>	<i>Delivery specification</i>
4.75 ... 15 V DC	6.194.012.F00	162 137	· LCD hour meter module type 194
9 ... 60 V DC	6.194.012.G00	162 138	· Operating instructions

- Product overview Basics
- Pulse counters
- Preset counters
- Hour meters Timers
- Frequency displays Tachometers
- Position displays
- Multifunction devices
- Energy meters
- Process devices
- Temperature devices
- Strain-gauge controllers
- Accessories Index

Hour meters / timers, electronic

LCD time modules	Max. time range 9999.99 h (DC)	194
-------------------------	---------------------------------------	------------

Technical data

General technical data	
Display	6 digits, LCD display, figure height 6 mm [0.24"]
Display range	9999.99 h
Data backup	CMOS EEPROM non-volatile memory up to 10 years
Operating temperature	-40°C ... +85°C [-40°F ... +185°F] (non-condensing)
Working temperature	-20°C ... +80°C [-4°F ... +176°F] (non-condensing)
Storage temperature	-50°C ... +90°C [-58°F ... +194°F]

Electrical characteristics	
Power supply	...F00 4.75 ... 15 V DC, with reverse polarity protection ...G00 9 ... 60 V DC
Current consumption	...F00 8 mA at 4.75 ... 15 V DC ...G00 6 mA at 9 ... 60 V DC
EMC standards	EN 55011 class B EN 61000-6-2, EN 61000-6-3 EN 61326-1

The module must be protected against inductive voltage spikes and high energy noise interference.

Mechanical characteristics	
Housing	color black
Weight	approx. 8 g [0.28 oz]
Shock resistance acc. to DIN-IEC 68-2-27	550 m/s ² , 11 ms
Vibration resistance acc. to DIN-IEC 68-2-6	50 ... 200 m/s ² , 10 ... 80 Hz

Inputs	
Reset input	HIGH 4 ... 60 V DC LOW 0 ... 0.7 V DC pulse length min. 1 ms, edge triggered (rising)
Measuring error	a max. error of 36 sec. occur per Start/Stop cycle
Accuracy (Quarz)	max. 200 ppm 25°C [+77°F]

Terminal assignment

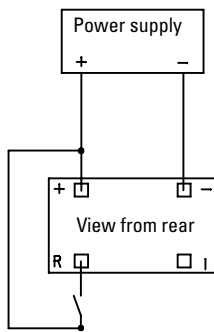

Dimensions

Dimensions in mm [inch]

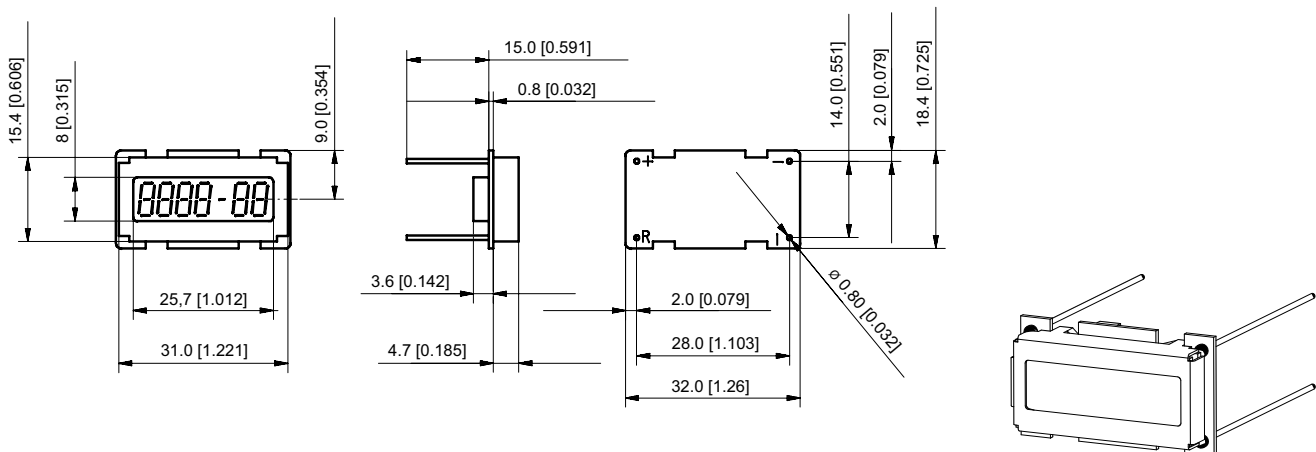

Product overview
Basics
Pulse counters
Preset counters
Hour meters
Timers
Frequency displays
Tachometers
Position displays
Multifunction devices
Energy meters
Process devices
Temperature devices
Strain-gauge controllers
Accessories
Index

Hour meters / timers, electronic

LCD time modules	Max. time range 99999.9 h (DC)	198
-------------------------	---------------------------------------	------------



The timer module of the type 198 with 6-digit LCD display for PCB mounting features a wide voltage range from 8 to 28 V DC.

It is extremely robust and suitable for many different applications thanks to its wide temperature range.



Timer	DC 8 ... 28 V	PNP	High shock resistance	Temperature range - 40° + 85°	PCB mount	6 LCDs	Electrical reset
-------	------------------	-----	-----------------------	----------------------------------	-----------	--------	------------------

Powerful

- Display range up to 99999.9 hours.
- 6-digit LCD display, 5 mm high.
- Low power consumption.
- Wide voltage and temperature range.
- Very high shock and vibration resistance.

Simple

- Non-volatile memory (no battery).
- Start/Stop input.
- Electrical reset.
- Very high reliability.
- Small size and low cost.

Order specifications		
<i>Power supply</i>	<i>Order no.</i>	<i>Delivery specification</i>
8 ... 28 V DC	6.198.012.H00 ¹⁾	<ul style="list-style-type: none"> • LCD counter module type 198 • Operating instructions

1) Stock types

- Product overview Basics
- Pulse counters
- Preset counters
- Hour meters Timers
- Frequency displays Tachometers
- Position displays
- Multifunction devices
- Energy meters
- Process devices
- Temperature devices
- Strain-gauge controllers
- Accessories Index

Hour meters / timers, electronic

LCD time modules	Max. time range 99999.9 h (DC)	198
-------------------------	---------------------------------------	------------

Technical data

General technical data	
Display	6 digits, LCD display, figure height 5 mm [0.20"]
Display range	99999.9 h
Data backup	CMOS EEPROM non-volatile memory up to 10 years (without battery)
Operating / working / storage temperature	-40°C ... +80°C [-40°F ... +185°F] (non-condensing)
Humidity	95 % RH at +32°C [+90°F] for max. 2 hours

Mechanical characteristics	
Housing	dimensions 18.4 x 32.4 mm [0.72 x 1.28"] color black
Weight	approx. 8 g [0.28 oz]
Vibration resistance acc. to DIN-IEC 68-2-6	10 ... 80 m/s ² , 10 ... 75 Hz

Electrical characteristics	
Power supply	8 ... 28 V DC
Current consumption	3 mA max. at 4.5 V DC 10 mA at 28 V DC
EMC standards	EN 55011 class B EN 61000-6-2, EN 61000-6-3 EN 61326-1, EN 61326-3-1

The module must be protected against inductive voltage spikes and high energy noise interference.

Inputs	
Start/Stop input (Enable input timer) On-times smaller than 16 sec will not be counted	8 ... 28 V DC
Reset input	8 ... 28 V DC pulse length min. 500 ms

Terminal assignment

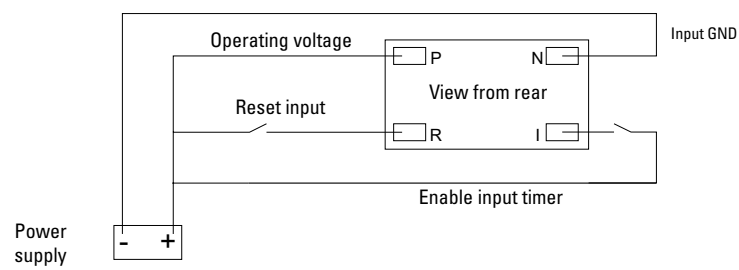

Dimensions

Dimensions in mm [inch]

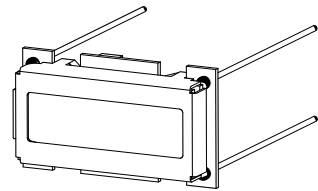
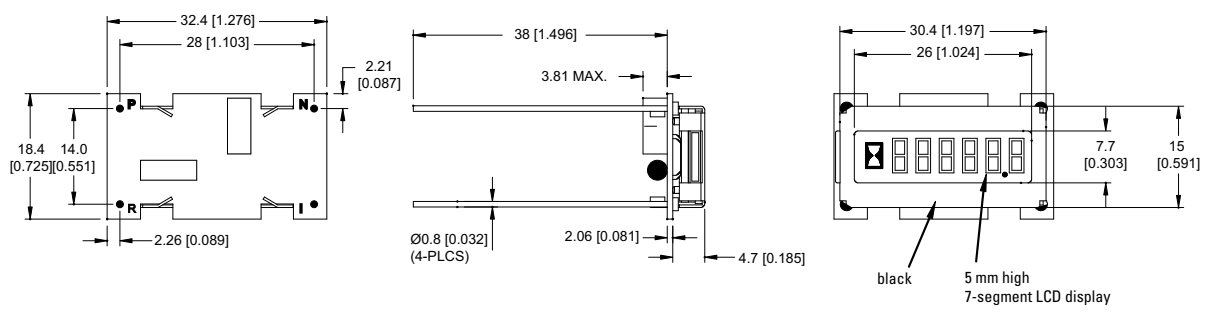

Product overview
Basics
Pulse counters
Preset counters
Hour meters
Timers
Frequency displays
Tachometers
Position displays
Multifunction devices
Energy meters
Process devices
Temperature devices
Strain-gauge controllers
Accessories
Index

Hour meters / timers, electromechanical

Micro timers	High shock resistance (DC)	HK 47
---------------------	-----------------------------------	--------------

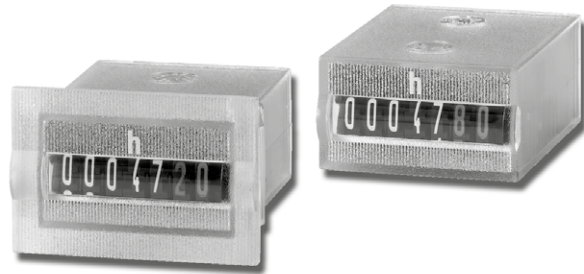

The micro timers HK 47 have a very high shock resistance.

Available as panel and PCB mount versions, they can be used in many different fields of application. Thanks to their encapsulated housing, these non-resettable counters are extremely tamper-proof.

Product overview
Basics

Pulse counters

Preset counters

Hour meters
Timers

Frequency displays
Tachometers

Position displays

Multifunction
devices

Energy meters

Process devices

Temperature
devices

Strain-gauge
controllers

Accessories
Index

Characteristics

- 7-digit micro hour meter.
- Low cost.
- High shock resistance.
- Small dimensions.
- Magnified large figures.
- Different reading possibilities.
- Panel-mount counter with integrated spring clip (HK 47.20).
- PCB mount counter (HK 47.80).

Benefits

- Low power consumption; suitable for battery operation.
- Solderable and wash-proof (HK 47.80).
- Data retention in case of power failure.
- Long service life.

Applications

Time registration, maintenance intervals for measuring instruments (respiration units, oxygen, dialysis), small appliances, UV lamps, display panels.

Type series

Fig.	Mounting options	Display	Protection	El. connection	Type
1)	Panel mount with latch	front side	IP65, front side	flying leads	HK 47.20
2)	PCB mount, upright	front side	IP65, front side/on rear	solder pins	HK 47.80

Mounting options and position of the display

1) Panel mount
display front side

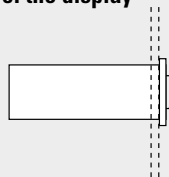

2) PCB mount, upright
display front side

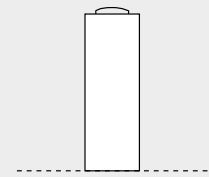

Technical data	
Drive	pulse-driven, precision crystal controller via electronic divider circuit
Pulse duration	32 ms; every 36 s = 0.01 h power on times < 36 s are not counted
Electrical connection	HK 47.20 flying leads AWG 22, approx. 150 mm [5.91"] long (red +, black -) HK 47.80 solder pins \varnothing 0.64 mm [0.025"]
Display	99999.99 h
Counting drum	figures white on black, decimal place red on black
Rated Voltage	4.5 ... 35 V DC
Residual ripple	< 1 %
Current consumption	< 1.5 mA (average)
Power consumption	(count pulses every 36 s with a pulse duration of 32 ms)
	at $U_B = 5$ V DC typ. 82 mW
	at $U_B = 12$ V DC typ. 135 mW
	at $U_B = 24$ V DC typ. 135 mW
	max. 170 mW

Accuracy	22.5 ppm at 25°C [77°F]
Height of figures	4 x 1.25 mm [0.16 x 0.049"]
Reset	no reset
Operating temperature	-10°C ... +60°C [+14°F ... +140°F] (non-condensing)
Storage temperature	-20°C ... +70°C [-4°F ... +158°F]
Mounting position	horizontal (other on request)
Solderable and wash proof version	HK 47.80
Soldering temperature	265°C [+509°F], 3 s
Protection	HK 47.80 IP65
(acc. to EN 60529)	HK 47.20 IP65 (front side)
EMC standards	EN 55011 class B EN 61000-6-2, EN 61000-6-3
Housing	PC transparent; HK 47.80 fully sealed (potted)
Weight	13 ... 15 g [0.46 ... 0.53 oz]

Hour meters / timers, electromechanical

Micro timers	High shock resistance (DC)	HK 47
---------------------	-----------------------------------	--------------

Options	
HK 47.20, HK 47.80	flat pin 0.8 x 2.8 mm [0.031 x 0.11"] and push-on connectors
HK 47.20	solder pins \varnothing 0.64 x 1.2 mm [0.025 x 0.047"]
HK 47.80	flying leads AWG 22 approx. 150 mm [5.91"] long

**Panel mount
with injection-moulded spring-clips
Type HK 47.20**

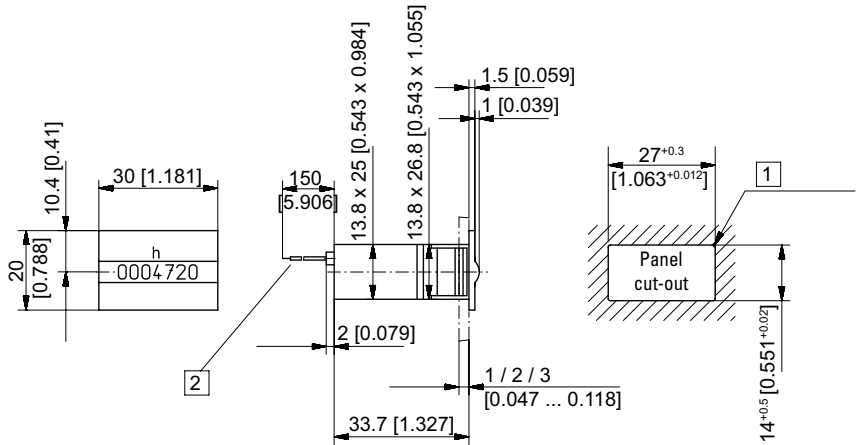
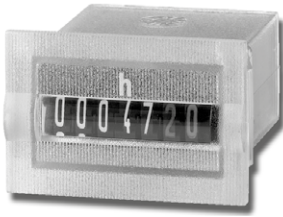

1) R_{max} 0.5 2) Flying leads AWG 22 (red+ / black-)

Type	Display	Art. no. 4.5 ... 35 V DC
HK 47.20	99999.99 h	3.060.200.383 ¹⁾

**PCB mount
Type HK 47.80**

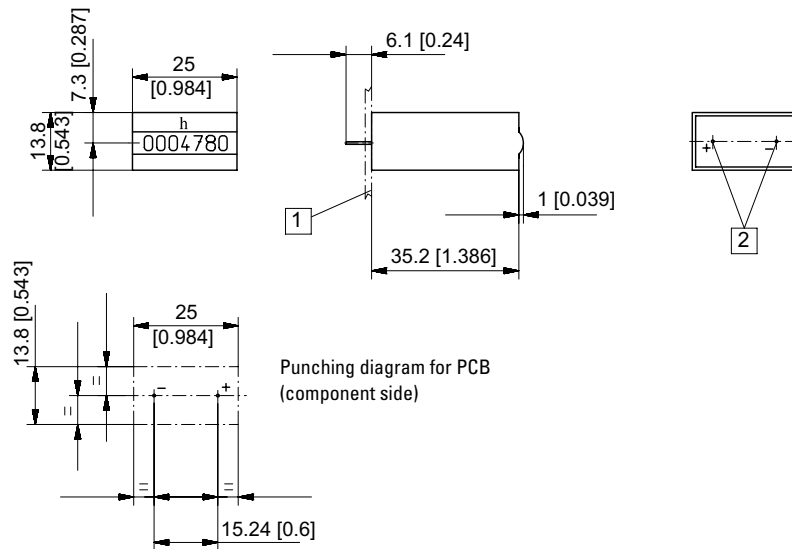

1) PCB 2) Solder pins \varnothing 0.64 [0.025]

Type	Display	Art. no. 4.5 ... 35 V DC
HK 47.80	99999.99 h	3.060.800.383

Hour meters / timers, electromechanical

Micro timers	Many different installation options (DC)	HK 07 / AHK 07
---------------------	---	-----------------------



The micro timers of the HK 07 and AHK 07 families offer a particularly large number of variants and can be used in many different applications thanks to their wide voltage range from 4.5 to 35 V DC.

Available as panel, base and PCB mount versions, they can be used in many different fields of application. Thanks to their encapsulated housing, these non-resettable counters are extremely tamper-proof.

Product overview
Basics

Pulse counters

Preset counters

Hour meters
Timers

Frequency displays
Tachometers

Position displays

Multifunction
devices

Energy meters

Process devices

Temperature
devices

Strain-gauge
controllers

Accessories
Index

Characteristics

- 7-digit micro hour meter.
- High shock and impact resistance.
- Low power consumption; suitable for battery operation.
- Small dimensions – magnified large figures.
- Panel-mount counter with integrated spring clip.
- PCB-mount counter.
- Machine-solderable and wash-proof.
- Protection IP65.

Benefits

- Wide voltage range 4.5 ... 35 V DC.
- Count retention in case of power failure.
- Long service life.

Applications

General time measurement, maintenance intervals for measuring instruments (respiration units, oxygen, dialysis), small appliances, UV lamps, display panels in vehicles.

Type series

Fig.	Mounting options	Display	Protection	El. connection	Housing	Height of fig.	Type
1)	Panel mount with latch	front side	IP65, front side	flying leads	plastic	4 mm [0.16"]	HK 07.20
2)	PCB mount, lying	on the top	IP65, front side/on rear	solder pins	plastic	4 mm [0.16"]	HK 07.90
4)	PCB mount, upright	front side	IP65, front side/on rear	solder pins	plastic	4 mm [0.16"]	HK 07.92
5)	Base mount, upright	front side	IP40	flying leads	plastic	4 mm [0.16"]	AHK 07.00

Mounting options and position of the display

1) Panel mount
display front side

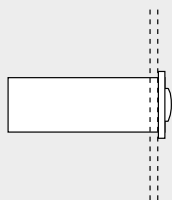

2) PCB mount, lying
display on the top



3) PCB mount, upright
display front side

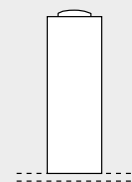

4) Base mount, upright
display front side

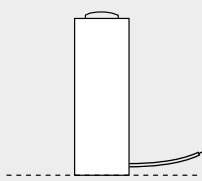

Optional: PCB mount, hanging
display front side

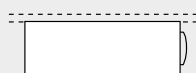

Accessories	Dimensions in mm [inch]	Order no.
Gasket 32 x 15 [1.26 x 0.59]	for cut-out 27 x 13 [1.06 x 0.51], suitable for HK 07.20	N511058

Hour meters / timers, electromechanical

Micro timers	Many different installation options (DC)	HK 07 / AHK 07
---------------------	---	-----------------------

Technical data		
Electrical connection	panel mount	flying leads, AWG 22 (red +, black -) approx. 150 mm [5.91"], 6 mm [0.24"] stripped wire ends, tinned
	PCB mount	solder pins 0.4 x 1.2 mm [0.016 x 0.047"], tinned
Power consumption (every 36 s with a pulse length of 32 ms)		
	at $U_B = 5\text{ V DC}$	typ. 82 mW
	at $U_B = 12\text{ V DC}$	typ. 135 mW
	at $U_B = 24\text{ V DC}$	typ. 135 mW max. 170 mW
Rated voltage	4.5 ... 35 V DC	
Residual ripple	< 1 %	
Current consumption	< 1.5 mA (average)	
On time	100 %	
Pulse duration	32 ms; every 36 s = 0.01 h On-times < 36 s will not be counted	
Number of digits	7: 99999.99 h	
Accuracy	22.5 ppm at 25°C [77°F]	

Height of figures	1.2 x 4.0 mm [0.047 x 0.16"]
Color of figures	white and red on black
Reset	no reset
Operating temperature	-10°C ... +60°C [+14°F ... +140°F] (non-condensing)
Mounting position	horizontal, other on request
Solderable and washproof versions	HK 07.90, HK 07.91, HK 07.92
Soldering temperature	265°C [+509°F], 3 s
Protection	up to IP65 depending on kind of type
EMC standards	EN 55011 class B EN 61000-6-2, EN 61000-6-3
Housing	plastic PC (Polycarbonate)
Weight	15 ... 18 g [0.53 ... 0.63 oz]

Options
HK 07.20 flat pin 0.8 x 2.8 mm [0.031 x 0.11"] (others on request)

Panel mount with latch / display front side
Type HK 07.20

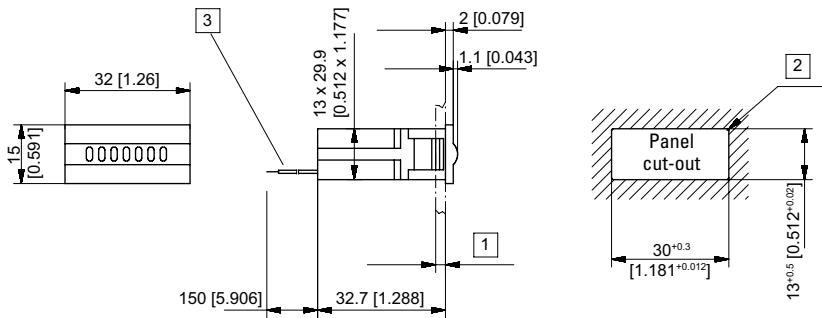

1) 1.2 ... 3 [0.047 x 0.12"] 2) $R_{max} 0.5$ 3) Flying leads (red+ / black-)

Type	Display	Art. no.
		4.5 ... 35 V DC
HK 07.20	7 digits	3.100.200.383 ¹⁾
HK 07.20.35 with flat pins	7 digits	3.107.200.383 ¹⁾

PCB mount, lying / display on the top
Type HK 07.90

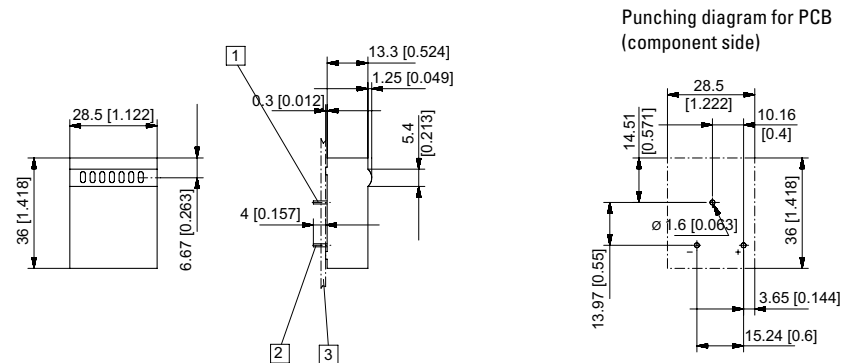
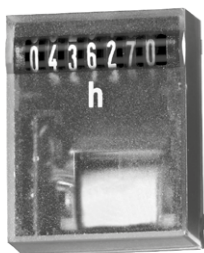

1) Mounting pin without el. function 0.4 x 1.2 [0.016 x 0.047]
2) Electrical connection 0.4 x 1.2 [0.016 x 0.047] 3) PCB

Type	Display	Art. no.
		4.5 ... 35 V DC
HK 07.90	7 digits	3.100.900.383

Hour meters / timers, electromechanical

Micro timers **Many different installation options (DC)** **HK 07 / AHK 07**

PCB mount, upright / display front side
Type HK 07.92

Punching diagram for PCB
(component side)

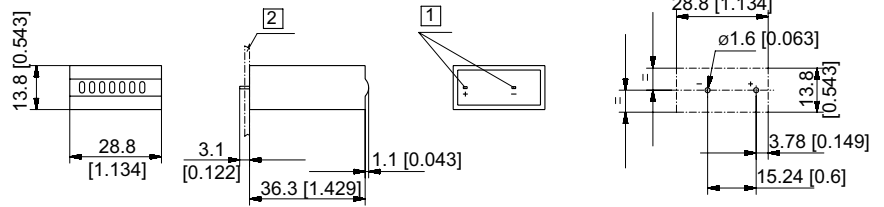

1) Electrical connection 0.4 x 1.2 [0.016 x 0.047] 2) PCB

Type	Display	Art. no.
HK 07.92	7 digits	3.100.920.383

Base mount, upright / display front side
Type AHK 07.00

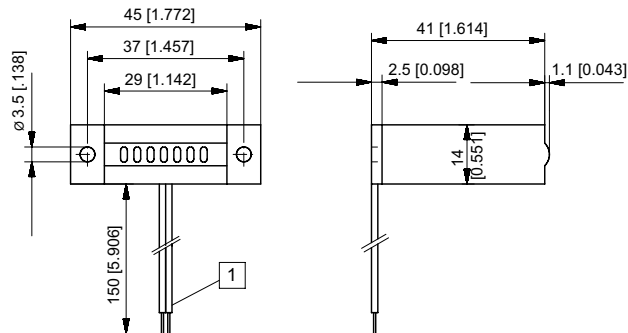

1) Flying leads (red+ / black-)

Type	Display	Art. no.
AHK 07.00	7 digits	3.100.000.383 ¹⁾

Product overview
Basics
Pulse counters
Preset counters
Hour meters
Timers
Frequency displays
Tachometers
Position displays
Multifunction devices
Energy meters
Process devices
Temperature devices
Strain-gauge controllers
Accessories
Index

Timers with DIN dimensions

Small format (AC+DC)

HK 17



The hour meters HK 17 feature a very high shock resistance.

These panel-mount counters are available in many panel sizes. They can be used in many different fields of application. These non-resettable counters are extremely tamper-proof.

Characteristics

- 7 or 8-digit hour meter.
- Without reset.
- High shock resistance.
- Small dimensions.
- Magnified large figures.
- Protection IP65 on the front side.
- UL-approved.

Benefits

- Many different front panel sizes and cut-outs.
- Data retention in case of power failure.
- Long service life.

Applications

General time measurement, maintenance intervals for medical equipment (respiration units, oxygen, dialysis), small appliances, UV lamps, display panels in vehicles.

Order code

HK17 . **a** **b** **c** **d** . **e** **f** . 56¹⁾

a Front bezel

- 0 = without front bezel (through housing)
- 2 = small front bezel with clip
- 4 = front bezel with holes at the side

b Type of housing

- 5 = housing black with welded viewing window

c Color

- 1 = black

d Electrical connection

- 11 = flat pin 0.8 x 6.3 mm [0.031 x 0.25"] (en option)
- 39 = screw terminal (standard) with flat pin 0.8 x 6.3 mm [0.031 x 0.25"]

Suitable gaskets as well as further accessories can be found in the accessories section or in the accessories area of our website at: www.kuebler.com/accessories.

Technical data

Electrical connection	flat pins 0.8 x 6.3 mm [0.031 x 0.25"] with screw terminals (max. tightening torque 0.8 Nm) or flat pins 0.8 x 6.3 mm [0.031 x 0.25"]																
Power consumption	<table border="0"> <tr> <td>10 ... 30 V DC</td> <td>approx. 500 mW</td> </tr> <tr> <td>36 ... 80 V DC</td> <td>approx. 900 mW</td> </tr> <tr> <td>100 ... 130 V DC</td> <td>approx. 750 mW</td> </tr> <tr> <td>20 ... 30 V AC, 50 Hz</td> <td>approx. 0.3 VA</td> </tr> <tr> <td>42 ... 48 V AC, 50 Hz</td> <td>approx. 0.25 VA</td> </tr> <tr> <td>100 ... 130 V AC, 50 Hz</td> <td>approx. 0.6 VA</td> </tr> <tr> <td>187 ... 264 V AC, 50 Hz</td> <td>approx. 1.2 VA</td> </tr> <tr> <td>360 ... 440 V AC, 50 Hz</td> <td>approx. 1.65 VA</td> </tr> </table>	10 ... 30 V DC	approx. 500 mW	36 ... 80 V DC	approx. 900 mW	100 ... 130 V DC	approx. 750 mW	20 ... 30 V AC, 50 Hz	approx. 0.3 VA	42 ... 48 V AC, 50 Hz	approx. 0.25 VA	100 ... 130 V AC, 50 Hz	approx. 0.6 VA	187 ... 264 V AC, 50 Hz	approx. 1.2 VA	360 ... 440 V AC, 50 Hz	approx. 1.65 VA
10 ... 30 V DC	approx. 500 mW																
36 ... 80 V DC	approx. 900 mW																
100 ... 130 V DC	approx. 750 mW																
20 ... 30 V AC, 50 Hz	approx. 0.3 VA																
42 ... 48 V AC, 50 Hz	approx. 0.25 VA																
100 ... 130 V AC, 50 Hz	approx. 0.6 VA																
187 ... 264 V AC, 50 Hz	approx. 1.2 VA																
360 ... 440 V AC, 50 Hz	approx. 1.65 VA																
Rated voltages	<table border="0"> <tr> <td>AC (50 or 60 Hz)</td> <td>20 ... 30 V, 42 ... 48 V, 100 ... 130 V, 187 ... 264 V, 360 ... 440 V</td> </tr> <tr> <td>DC</td> <td>10 ... 30 V, 36 ... 80 V, 100 ... 130 V</td> </tr> </table>	AC (50 or 60 Hz)	20 ... 30 V, 42 ... 48 V, 100 ... 130 V, 187 ... 264 V, 360 ... 440 V	DC	10 ... 30 V, 36 ... 80 V, 100 ... 130 V												
AC (50 or 60 Hz)	20 ... 30 V, 42 ... 48 V, 100 ... 130 V, 187 ... 264 V, 360 ... 440 V																
DC	10 ... 30 V, 36 ... 80 V, 100 ... 130 V																
Number of digits	<table border="0"> <tr> <td>7 at AC</td> <td>99999.99 h</td> </tr> <tr> <td>8 at DC</td> <td>999999.99 h</td> </tr> </table>	7 at AC	99999.99 h	8 at DC	999999.99 h												
7 at AC	99999.99 h																
8 at DC	999999.99 h																
Accuracy	<table border="0"> <tr> <td>AC</td> <td>supply frequency + 30 ms</td> </tr> <tr> <td>DC</td> <td><0.003 % (at 24 h)</td> </tr> </table>	AC	supply frequency + 30 ms	DC	<0.003 % (at 24 h)												
AC	supply frequency + 30 ms																
DC	<0.003 % (at 24 h)																

1) 56 for front bezel 36 x 24 mm [1.42 x 0.94"]

2) The version 360 ... 440 V AC is not UL listed

Height of figures	3.8 x 1.7 mm [0.15 x 0.067"] optical				
Color of figures	white and red on black				
Operating temperature	-15°C ... +50°C [+5°F ... +122°F] (non-condensing)				
Storage temperature	-40°C ... +85°C [-40°F ... +185°F]				
Mounting position	any				
Protection	IP65 (front side)				
EMC standards	EN 55011 class B EN 61000-6-2, EN 61000-6-3				
Device safety	<table border="0"> <tr> <td>designed to protection class</td> <td>EN 61010 part 1</td> </tr> <tr> <td>application area</td> <td>2 pollution level 2</td> </tr> </table>	designed to protection class	EN 61010 part 1	application area	2 pollution level 2
designed to protection class	EN 61010 part 1				
application area	2 pollution level 2				
UL approval	file E128604 ²⁾				
Housing	plastic PC (Polycarbonate) types with protection IP65 are sealed				
Weight	approx. 40 g [1.41 oz]				

Options

Counter with flat pin 0.8 x 6.3 mm [0.031 x 0.25"] Art. no. 3.138.X51.XXX

Hour meters / timers, electromechanical

Timers with DIN dimensions **Small format (AC+DC)** **HK 17**

Panel mount with mounting clip
Type HK 17.251.39

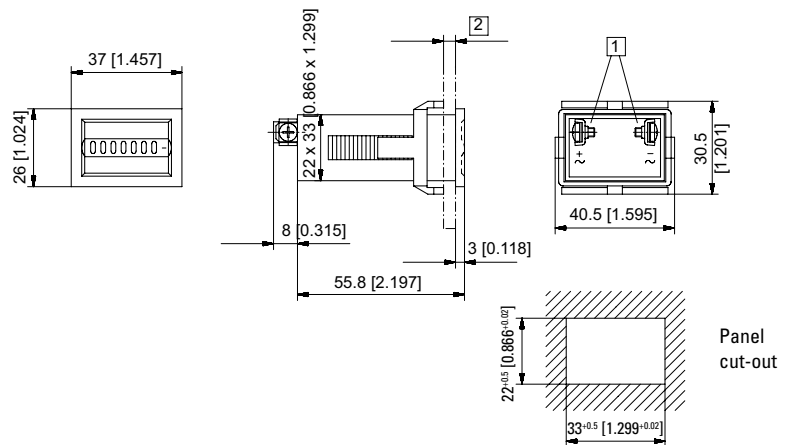

1) Screw terminal with flat pin 0.8 x 6.3 [0.031 x 0.25] 2) max. 26 [1.02]

Type	Display	Voltage	Art. no.						
			10 ... 30 V	20 ... 30 V	36 ... 80 V	42 ... 48 V	100 ... 130 V	187 ... 264 V	360 ... 440 V
HK 17.251.39	7 digits	AC (50 Hz)		3.130.251.071		3.130.251.072	3.130.251.074	3.130.251.075 ¹⁾	3.130.251.079
	7 digits	AC (60 Hz)		3.130.251.081		3.130.251.082	3.130.251.084	3.130.251.085	3.130.251.089
	8 digits	DC	3.130.251.351 ¹⁾		3.130.251.353		3.130.251.381		

Panel mount with mounting clips
Type HK 17.251.39.56

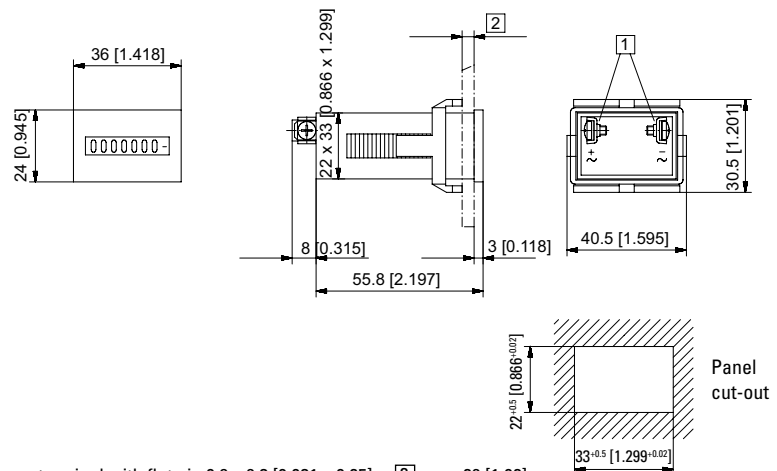
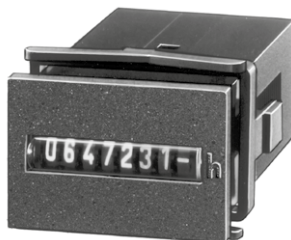

1) Screw terminal with flat pin 0.8 x 6.3 [0.031 x 0.25] 2) max. 26 [1.02]

Type	Display	Voltage	Art. no.						
			10 ... 30 V	20 ... 30 V	36 ... 80 V	42 ... 48 V	100 ... 130 V	187 ... 264 V	360 ... 440 V
HK 17.251.39.56	7 digits	AC (50 Hz)		3.130.251.071.056		3.130.251.072.056	3.130.251.074.056	3.130.251.075.056 ¹⁾	3.130.251.079.056
	7 digits	AC (60 Hz)		3.130.251.081.056		3.130.251.082.056	3.130.251.084.056	3.130.251.085.056	3.130.251.089.056
	8 digits	DC	3.130.251.351.056 ¹⁾		3.130.251.353.056		3.130.251.381.056		

Hour meters / timers, electromechanical

Timers with DIN dimensions **Small format (AC+DC)** **HK 17**

Base mount with central fixing on rear
Type HK 17.051.39

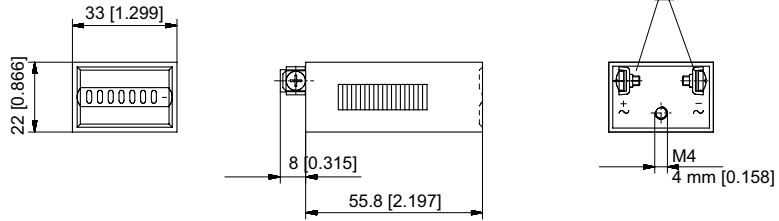

1) Screw terminal with flat pin 0.8 x 6.3 [0.031 x 0.25]

Type	Display	Voltage	Art. no.						
			10 ... 30 V	20 ... 30 V	36 ... 80 V	42 ... 48 V	100 ... 130 V	187 ... 264 V	360 ... 440 V
HK 17.051.39	7 digits	AC (50 Hz)		3.130.051.071		3.130.051.072	3.130.051.074	3.130.051.075	3.130.051.079
	7 digits	AC (60 Hz)		3.130.051.081		3.130.051.082	3.130.051.084	3.130.051.085	3.130.051.089
	8 digits	DC	3.130.051.351		3.130.051.353		3.130.051.381		

Panel mount with 2 holes at the side
Type HK 17.451.39

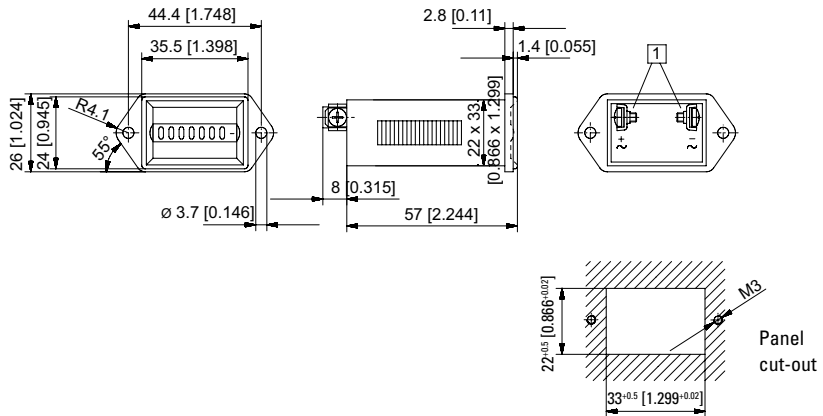
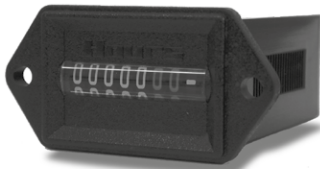

1) Screw terminal with flat pin 0.8 x 6.3 [0.031 x 0.25]

Type	Display	Voltage	Art. no.						
			10 ... 30 V	20 ... 30 V	36 ... 80 V	42 ... 48 V	100 ... 130 V	187 ... 264 V	360 ... 440 V
HK 17.451.39	7 digits	AC (50 Hz)		3.130.451.071		3.130.451.072	3.130.451.074	3.130.451.075 ¹⁾	3.130.451.079
	7 digits	AC (60 Hz)		3.130.451.081		3.130.451.082	3.130.451.084	3.130.451.085	3.130.451.089
	8 digits	DC	3.130.451.351		3.130.451.353		3.130.451.381		

Hour meters / timers, electromechanical

Timers with DIN dimensions **DIN counters for panel mount, 48 x 24 mm (AC+DC)** **H 37**



The hour meters H 37 feature a very high shock resistance. These panel mount counters with standard DIN dimensions can be used in many different fields of application. These non-resettable counters are extremely tamper-proof.

Product overview Basics
Pulse counters
Preset counters
Hour meters Timers
Frequency displays Tachometers
Position displays
Multifunction devices
Energy meters
Process devices
Temperature devices
Strain-gauge controllers
Accessories Index

Characteristics

- 7- or 8-digit hour meter.
- Without reset, high shock resistance.
- Small dimensions, magnified large figures.
- Protection IP65 on the front side.
- Panel mount counter with integrated spring clip (H 37.4).
- UL-approved.

Benefits

- 5 years guarantee. ¹⁾
- High reliability: for a better sale of your final product.
- Data retention in case of power failure.
- Long service life.

Applications

General time measurement, maintenance intervals for measuring instruments (respiration units, oxygen, dialysis), small appliances, UV lamps, display panels in vehicles.

Type series

Description	Mounting	Panel cut-out	Type
Standard DIN counter for panel mount	mounting clip, on rear	45 x 22 [1.77 x 0.91"]	H 37
Standard DIN counter for panel mount	2 mounting holes	50 x 25 [1.97 x 0.98"]	H 37.1
Standard DIN counter for panel mount	mounting clip, on rear	50 x 25 [1.97 x 0.98"]	H 37.2
Standard DIN counter for panel mount	mounting clip, on rear	45 x 22 [1.77 x 0.91"]	H 37.5

Dual function timer
48 x 48 mm [1.89 x 1.89"] on request



1) When used as specified in the technical data

Hour meters / timers, electromechanical

Timers with DIN dimensions	DIN counters for panel mount, 48 x 24 mm (AC+DC)	H 37	
Accessories	Dimensions in mm [inch]		Order no.
Adapter front bezel, 72 x 36 [2.83 x 1.42]	for cut-out 68 x 33 [2.68 x 1.30] to cut-out 45 x 22.2 [1.77 x 0.87], for counters 48 x 24 [1.89 x 0.94], as set	black and silver anodised	162704 Set
Adapter front bezel, 48 x 48 [1.89 x 1.89]	for cut-out 45 x 45 [1.77 x 1.77] to cut-out 45 x 22.2 [1.77 x 0.87], with clip mounting for counters 48 x 24 [1.89 x 0.94]	black	T008883
Adapter front bezel, 60 x 50 [2.36 x 1.97]	for cut-out 54 x 29 [2.13 x 1.14] to cut-out 45 x 22.2 [1.77 x 0.87], with screw mounting and gasket for counters 48 x 24 [1.89 x 0.94]	black	N003001
Adapter front bezel, 56 x 40 [2.20 x 1.57]	for cut-out 50 x 25 [1.97 x 0.98] to cut-out 45 x 22.2 [1.77 x 0.87], with screw mounting for counters 48 x 24 [1.89 x 0.94]	black	T008161
Adapter front bezel, 53 x 28 [2.09 x 1.10]	for cut-out 54 x 29 [2.13 x 1.14] to cut-out 45 x 22.2 [1.77 x 0.87], with clip mounting for counters 48 x 24 [1.89 x 0.94]	grey black	T008164 T008165
Transparent cover, lockable, IP65	for cut-out 54 x 29 [2.13 x 1.14], for screw mounting to front bezel F1B or adapter front bezel N003001, for counters with cut-out 50 x 25 [1.97 x 0.98] or 45 x 22.2 [1.77 x 0.87]		N003002
Sealing cover type K1, IP65	suitable for front bezel 60 x 50 [2.36 x 1.97], for screw mounting of electromech. counters and via adapter front bezel N003001 for counters 48 x 24 [1.89 x 0.94]		G008301
Mounting frame with cut-out 50 x 25 [1.97 x 1.97] via separate adapter also for 45 x 22.2 [1.77 x 0.87]	for snap-on mounting on 35 [1.38] top-hat DIN rail, for counters 53 x 28 [2.09 x 1.10] and via separate adapter (T008180) for counters 48 x 24 [1.89 x 0.94]	chromated	G300004
Gasket 53 x 28 [2.09 x 1.10]	for cut-out 50 x 25 [1.97 x 0.98], suitable for H 37.2 and H 37.4	black	N511015
Gasket 48 x 24 [1.89 x 0.94]	for cut-out 45 x 22.2 [1.77 x 0.87], suitable for H 37 and H 37.5	black	N511029
Terminal cover type KA 37	for H 37 counters (2 pcs. per counter required)	transparent	T051687

Suitable gaskets, other accessories and installation examples for optional accessories can be found in chapter accessories or in the accessories section under: www.kuebler.com/accessories.

Technical data	
Electrical connection	screw terminals (tightening torque max. 0.8 Nm)
Power consumption	10 ... 30 V DC approx. 500 mW 36 ... 80 V DC approx. 900 mW 100 ... 130 V DC approx. 750 mW 20 ... 30 V AC, 50 Hz approx. 0.3 VA 42 ... 48 V AC, 50 Hz approx. 0.25 VA 100 ... 130 V AC, 50 Hz approx. 0.6 VA 187 ... 264 V AC, 50 Hz approx. 1.2 VA
Rated voltages	AC (50 or 60 Hz) 20 ... 30 V, 42 ... 48 V, 100 ... 130 V, 187 ... 264 V DC 10 ... 30 V, 36 ... 80 V, 100 ... 130 V
On time	100 %
Number of digits	AC 7 – 99999.99 h DC 8 – 999999.99 h
Resolution	0.01 h equals 36 s
Height of figures	4 mm [0.16"]
Color of figures	white and red on black
Reset	no reset
Operating temperature	-15°C ... +50°C [+5°F ... +122°F] (non-condensing)
Storage temperature	-40°C ... +85°C [-40°F ... +185°F]
Relativ humidity	< 95 % (non-condensing)
Mounting position	any

Protection	IP65 (front side) built in with gasket, (order gasket separately)
EMC standards	EN 55011 class B EN 61000-6-2, EN 61000-6-3
Device safety	designed to EN 61010 part 1 protection class 2 application area pollution level 2
UL approval	file E128604
Housing	plastic PC (Polycarbonate) types with IP65 protection are sealed (potted)
Accuracy	AC supply frequency + 30 ms DC < 0.003 % (at 24 h)
Weight	H 37 approx. 50 g [1.76 oz] slip on bezel 37.1 6 g [0.21 oz] slip on bezel 37.2 2 g [0.07 oz]
Options	
Color of housing	grey Art. no. 3.130.X50.XXX
Electrical connection	flat pin 0.8 x 6.3 mm [0.031 x 0.25"] Art.-No.: 3.24X.20X.XXX.011 screw terminal with terminal cover Art.-No.: 3.24X.20X.XXX.456 spring-type terminal on request
360 - 440 V AC	on request

Hour meters / timers, electromechanical

Timers with DIN dimensions DIN counters for panel mount, 48 x 24 mm (AC+DC) H 37

Mounting clip, on rear,
panel mount dimensions 45 x 22 [1.77 x 0.91]
Type H 37

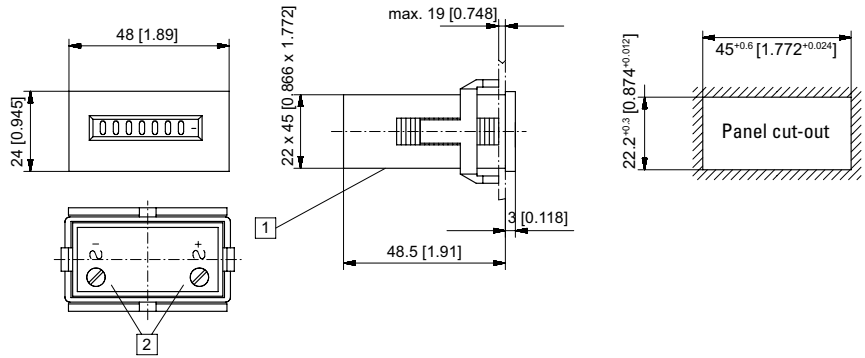

1 Wire entry 2 Screw terminal with flat pin 0.8 x 6.3 [0.031 x 0.25]

Type	Display	Voltage	Art. no.					
			10 ... 30 V	20 ... 30 V	36 ... 80 V	42 ... 48 V	100 ... 130 V	187 ... 264 V
H 37	7 digits	AC (50 Hz)		3.240.201.071		3.240.201.072	3.240.201.074 ¹⁾	3.240.201.075 ¹⁾
	7 digits	AC (60 Hz)		3.240.201.081		3.240.201.082	3.240.201.084	3.240.201.085
	8 digits	DC	3.240.201.351 ¹⁾	3.240.201.353		3.240.201.381		

2 mounting holes,
panel mount dimensions 50 x 25 [1.97 x 0.98"]
Type H 37.1

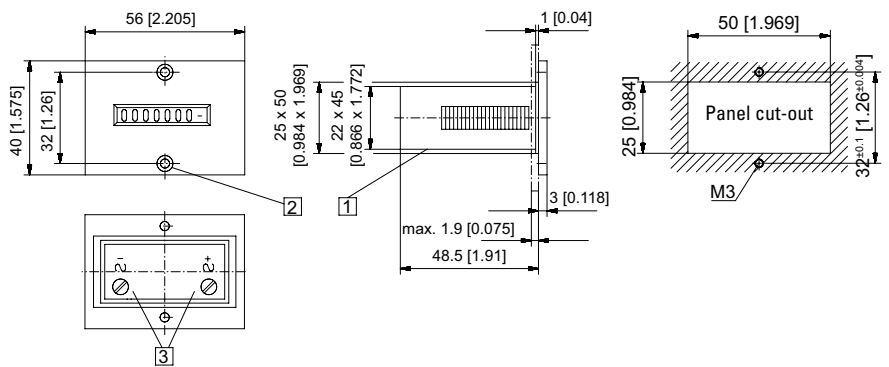

1 Wire entry 2 Countersinking Af3, DIN 74 3 Screw terminal with flat pin 0.8 x 6.3 [0.031 x 0.25]

Type	Display	Voltage	Art. no.					
			10 ... 30 V	20 ... 30 V	36 ... 80 V	42 ... 48 V	100 ... 130 V	187 ... 264 V
H 37.1	7 digits	AC (50 Hz)		3.241.201.071		3.241.201.072	3.241.201.074	3.241.201.075
	7 digits	AC (60 Hz)		3.241.201.081		3.241.201.082	3.241.201.084	3.241.201.085
	8 digits	DC	3.241.201.351 ¹⁾	3.241.201.353		3.241.201.381		

Mounting clip, on rear,
panel mount dimensions 50 x 25 [1.97 x 0.98"]
Type H 37.2

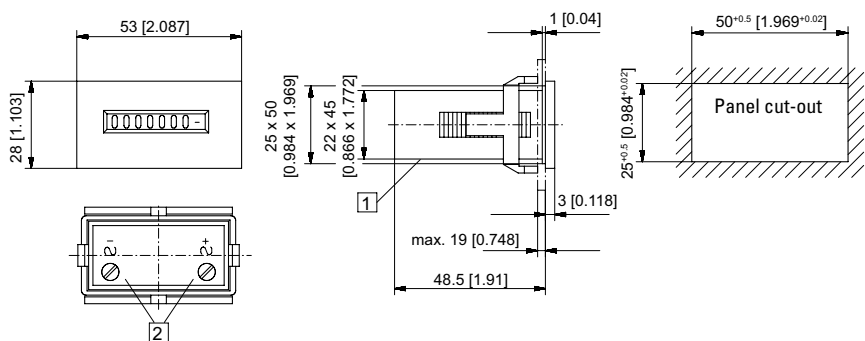

1 Wire entry 2 Screw terminal with flat pin 0.8 x 6.3 [0.031 x 0.25]

Type	Display	Voltage	Art. no.					
			10 ... 30 V	20 ... 30 V	36 ... 80 V	42 ... 48 V	100 ... 130 V	187 ... 264 V
H 37.2	7 digits	AC (50 Hz)		3.242.201.071		3.242.201.072	3.242.201.074	3.242.201.075 ¹⁾
	7 digits	AC (60 Hz)		3.242.201.081		3.242.201.082	3.242.201.084	3.242.201.085
	8 digits	DC	3.242.201.351 ¹⁾	3.242.201.353		3.242.201.381		

Dimensions in mm [inch]

1) Stock types

Product overview
Basics
Pulse counters
Preset counters
Hour meters
Timers
Frequency displays
Tachometers
Position displays
Multifunction devices
Energy meters
Process devices
Temperature devices
Strain-gauge controllers
Accessories
Index

Hour meters / timers, electromechanical

Timers with DIN dimensions **DIN counters for panel mount, 48 x 24 mm (AC+DC)** **H 37**

DIN counter for panel mount mounting clip, on rear, panel mount dimensions 45 x 22 [1.77 x 0.91] Type H 37.5

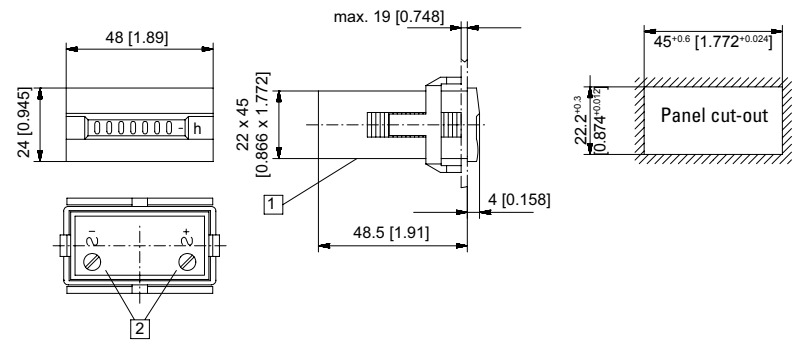

1 Wire entry 2 Screw terminal with flat pin 0.8 x 6.3 [0.031 x 0.25]

Type	Display	Voltage	Art. no.						
			10 ... 30 V	20 ... 30 V	36 ... 80 V	42 ... 48 V	100 ... 130 V	187 ... 264 V	
H 37.5	7 digits	AC (50 Hz)		3.245.201.071		3.245.201.072	3.245.201.074	3.245.201.075 ¹⁾	
	7 digits	AC (60 Hz)		3.245.201.081		3.245.201.082	3.245.201.084	3.245.201.085	
	8 digits	DC	3.245.201.351 ¹⁾		3.245.201.353		3.245.201.381		

- Product overview Basics
- Pulse counters
- Preset counters
- Hour meters Timers
- Frequency displays Tachometers
- Position displays
- Multifunction devices
- Energy meters
- Process devices
- Temperature devices
- Strain-gauge controllers
- Accessories Index

Dimensions in mm [inch]

1) Stock types

Hour meters / timers, electromechanical

Timers with DIN dimensions **DIN counter for panel mount / DIN rail housing, 48 x 48 mm** **H 57 / AH 57**



The hour meters H 57, H 57.55, H 57.72 and AH 57 feature a very high shock resistance. These panel / DIN rail mount counters have a reduced mounting depth. They can be used in many different fields of application. These non-resettable counters are extremely tamper-proof.

Product overview
Basics
Pulse counters
Preset counters
Hour meters
Timers
Frequency displays
Tachometers
Position displays
Multifunction devices
Energy meters
Process devices
Temperature devices
Strain-gauge controllers
Accessories
Index

<h3>Characteristics</h3> <ul style="list-style-type: none"> • 7 or 8-digit hour meter. • High shock and impact resistance. • Without reset, small mounting depth. • Magnified large figures. • Protection IP52 (optional IP65), suitable for any mounting position. • UL-approved. • Various front bezel sizes <ul style="list-style-type: none"> - H 57 48 x 48 mm - H 57.55 55 x 55 mm - H 57.72 72 x 72 mm - AH 57 48 x 48 mm for DIN rail 	<h3>Benefits</h3> <ul style="list-style-type: none"> • 5 years guarantee. ¹⁾ • High reliability: for a better sale of your final product. • Data retention in case of power failure. • Long service life. <h3>Applications</h3> <p>General time measurement, maintenance intervals for measuring instruments (respiration units, oxygen, dialysis), small appliances, UV lamps, display panels in vehicles</p>
--	---

Type series			
Description	Mounting	Front bezel	Type
Standard DIN timer	clip mounting, on rear	48 x 48 mm [1.89 x 1.89"]	H 57
Standard DIN timer	clip mounting, on rear	55 x 55 mm [1.97 x 1.97"]	H 57.55
Standard DIN timer	clip mounting, on rear	72 x 72 mm [2.83 x 2.83"]	H 57.72
Base mount timer	DIN rail 35 mm [1.38"] acc. to DIN EN 50022		AH 57

Accessories	Dimensions in mm [inch]	Order no.
Adapter front bezel, 55 x 55 [2.17 x 2.17]	for cut-out 50 x 50 [1.97 x 1.97] or ø 50.5 [2.17] to cut-out 45 x 45 [1.77 x 1.77], with clip mounting for counters 48 x 48 [1.89 x 1.89]	T008171
Adapter front bezel, 60 x 75 [2.36 x 2.95]	for cut-out 50 x 50 [1.97 x 1.97] to cut-out 45 x 45 [1.77 x 1.77] with screw mounting for counters 48 x 48 [1.89 x 1.89]	T008860
Adapter front bezel, 72 x 72 [2.83 x 2.83]	for cut-out 68 x 68 [2.68 x 2.68] to cut-out 45 x 45 [1.77 x 1.77] (Mating clip T009420 must be ordered separately)	T008177
Adapter front bezel, ø 72 [2.83]	for cut-out ø 60 [2.36] to 45 x 45 [1.77 x 1.77], with clip mounting for counters 48 x 48 [1.89 x 1.89]	N510226
Base-mount socket	for H 57	G008040

Suitable gaskets, other accessories and installation examples for optional accessories can be found in chapter accessories or in the accessories section under: www.kuebler.com/accessories.

1) When used as specified in the technical data

Hour meters / timers, electromechanical

Timers with DIN dimensions **DIN counter for panel mount / DIN rail housing, 48 x 48 mm** **H 57 / AH 57**

Technical data	
Electrical connection	screw terminals (tightening torque max. 0.8 Nm) wire entry from behind, for \varnothing 2.5 mm ² [AWG13]
Power consumption	10 ... 30 V DC approx. 500 mW 100 ... 130 V DC approx. 750 mW 20 ... 30 V AC, 50 Hz approx. 0.3 VA 42 ... 48 V AC, 50 Hz approx. 0.25 VA 100 ... 130 V AC, 50 Hz approx. 0.6 VA 187 ... 264 V AC, 50 Hz approx. 1.2 VA 360 ... 440 V AC, 50 Hz approx. 1.65 VA
Rated voltages	AC (50 or 60 Hz) 20 ... 30 V, 42 ... 48 V, 100 ... 130 V, 187 ... 264 V, 360 ... 440 V DC 10 ... 30 V, 36 ... 80 V, 100 ... 130 V
On time	100 %
Number of digits	7 at AC 99999.99 h 8 at DC 999999.99 h
Count mode	adding
Height of figures	4 mm [0.16"]
Color of figures	white and red on black
Operating temperature	-15°C ... +50°C [+5°F ... +122°F] (non-condensing)
Storage temperature	-40°C ... +85°C [-40°F ... +185°F]
Relative humidity	< 95 % (non-condensing)
Mounting position	any
Protection	IP52, DIN 40050 (front side)
EMC standards	EN 55011 class B EN 61000-6-2, EN 61000-6-3
Device safety	designed to EN 61010 part 1 protection class 2 application area pollution level 2
UL approval	file E128604 the version 360 ... 440 V AC is not UL listed
Housing	plastic PC (Polycarbonate)
Accuracy	AC supply frequency + 30 ms DC < 0.003 % (at 24 h)
Weight	H 57 approx. 48 g [1.69 oz] base mount socket no. 48 36 g [1.27 oz] slip-on bezel 55 8 g [0.28 oz] slip-on bezel 72 13 g [0.46 oz]
Operating indicator of the running time meter	AC fast rotating wheel with red dashes DC 1/100 h display turns continuously by 1 digit in 36 s
Test voltage	2000 V AC, 50 Hz for AC counters

Options	
Color of housing	grey Art. no. 3.22X.400.XXX
Timer H 57.55 mounted with adapter front bezel 55 x 55 mm [2.17 x 2.17"]	Art. no. 3.221.XXX.XXX
Timer H 57.72 montiert mit Adapter-Frontrahmen 72 x 72 mm [2.83 x 2.83"]	Art. no. 3.222.XXX.XXX
Electrical connection	flat pin 0.8 x 6.3 mm [0.031 x 0.25"] Art.-No.: 3.228.401.XXX
IP65 version, welded front cover	H 57 Art. no. 3.220.XXX.XXX.422 H 57.55 Art. no. 3.221.XXX.XXX.423 H 57.72 Art. no. 3.222.XXX.XXX.424
Required gaskets	between the counter and the bezel H 57 N511018
Gasket set	H 57.55 N511018 + N511017 H 57.72 N511018 + N511016
(with the IP65 version, the gasket is included in the delivery)	
Further voltages on request	
Counter with cable inlet from underneath, screw fixing from rear Art. no. 3.220.401.XXX.044	

Product overview Basics
Pulse counters
Preset counters
Hour meters Timers
Frequency displays Tachometers
Position displays
Multifunction devices
Energy meters
Process devices
Temperature devices
Strain-gauge controllers
Accessories Index

Hour meters / timers, electromechanical

Timers with DIN dimensions **DIN counter for panel mount / DIN rail housing, 48 x 48 mm** **H 57 / AH 57**

Standard DIN timer
clip mounting, on rear
Type H 57

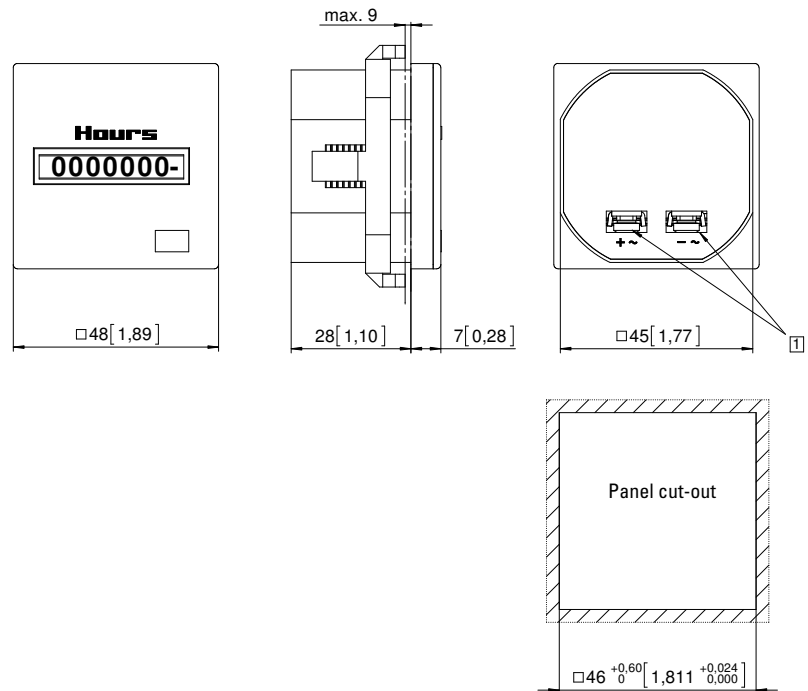

1) Screw terminal with flat pin x 6.3 [0.031 x 0.25]

Type	Display	Voltage	Art. no.					
			10 ... 30 V	20 ... 30 V	42 ... 48 V	100 ... 130 V	187 ... 264 V	360 ... 440 V
H 57	7 digits	AC (50 Hz)		3.220.401.071 ¹⁾	3.220.401.072	3.220.401.074 ¹⁾	3.220.401.075 ¹⁾	3.220.401.079
	7 digits	AC (60 Hz)		3.220.401.081 ¹⁾	3.220.401.082	3.220.401.084 ¹⁾	3.220.401.085 ¹⁾	3.220.401.089
	8 digits	DC	3.220.401.351 ¹⁾			3.220.401.381		
Further stock types:			3.220.401.075.422	187... 264 V AC, IP65				
			3.220.401.351.422	10 ... 30 V DC, IP65				

Base mount timer
DIN rail mount 35 [1.38] acc. to DIN EN 50022
Type AH 57

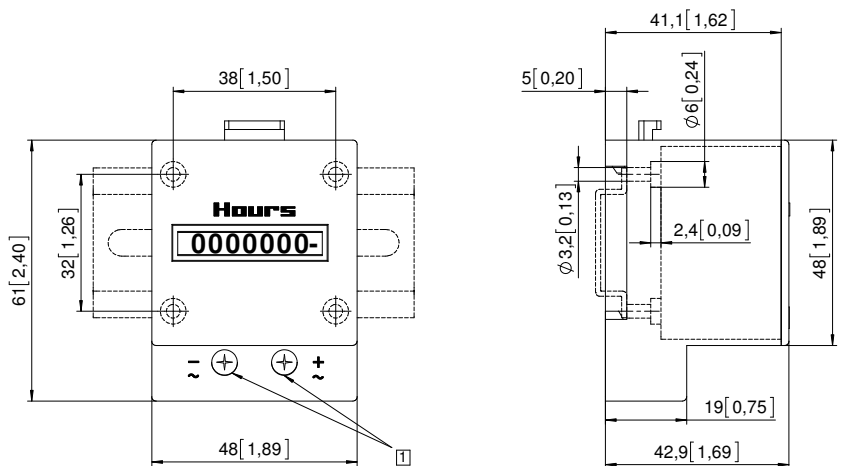

1) Screw terminals

Type	Display	Voltage	Art. no.					
			10 ... 30 V	20 ... 30 V	42 ... 48 V	100 ... 130 V	187 ... 264 V	360 ... 440 V
AH 57	7 digits	AC (50 Hz)		3.223.401.071	3.223.401.072	3.223.401.074 ¹⁾	3.223.401.075 ¹⁾	3.223.401.079
	7 digits	AC (60 Hz)		3.223.401.081	3.223.401.082	3.223.401.084 ¹⁾	3.223.401.085 ¹⁾	3.223.401.089
	8 digits	DC	3.223.401.351 ¹⁾			3.223.401.381		

Product overview
Basics
Pulse counters
Preset counters
Hour meters
Timers
Frequency displays
Tachometers
Position displays
Multifunction devices
Energy meters
Process devices
Temperature devices
Strain-gauge controllers
Accessories
Index

Timers for DIN rail mounting

Micro DIN rail housing (AC+DC)

SHK 07.1

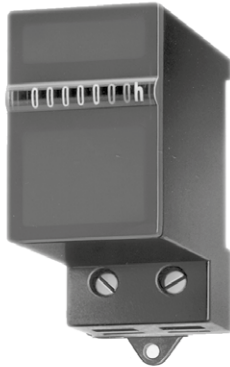

The micro timers SHK 07.1 feature a very high shock resistance.

These base and DIN rail mount counters can be used in many different fields of application. These non-resettable counters are extremely tamper-proof.

Characteristics

- 7-digit micro hour meter.
- DIN rail mount according to EN 50022.
- Base mount counter.
- High shock resistance.
- Low power consumption.
- Small dimensions.
- Magnified large figures.
- Display range 99999.99 h.

Benefits

- Wide voltage range 4.5 ...35 V DC, 20 ...264 V AC.
- Data retention in case of power failure.
- Long service life.

Applications

General time measurement, integration in control cabinets.

Type series

Description	Mounting	Type
Timer	DIN rail 35 mm [1.38"] acc. to DIN EN 50022	SHK 07.1

Technical data

Electrical connection	clamp terminal	up to 2.5 mm ² [AWG13]
	tightening torque max.	0.8 Nm
Power consumption (count pulses every 36 s with a pulse duration of 32 ms)	at U _B = 5 V DC	typ. 82 mW
	at U _B = 12 V DC	typ. 135 mW
	at U _B = 24 V DC	typ. 135 mW
	at U _B = 22 ... 32 V DC	typ. 170 mW
	20 ... 30 V AC	approx. 0.43 VA
100 ... 130 V AC	approx. 0.82 VA	
	187 ... 264 V AC	approx. 1.8 VA
On time	100 %	
Number of digits	7 (99999.99 h)	
Accuracy	22.5 ppm at 25°C [77°F]	
EMC standards	EN 55011 class B EN 61000-6-2, EN 61000-6-3	
Device safety	designed to protection class application area	EN 61010 part 1 2 pollution level 2

Height of figures	1.2 x 4 mm [0.047 x 0.016"]	
Color of figures	white and red on black	
Operating temperature	AC	-10°C ... +50°C [-40°F ... +122°F] (non-condensing)
	DC	-10°C ... +60°C [+14°F ... +140°F] (non-condensing)
Mounting position	horizontal, other on request	
Protection	up to IP52 depends on version	
Housing	plastic PC (Polycarbonate)	
Weight	approx. 55 g [1.94 oz]	

Options

Color of housing	grey
Temperature range	-30°C ... +85°C [-22°F ... +185°F]
Version with 6 digits width of figures	1.7 mm [0.067"]

Product overview
Basics

Pulse counters

Preset counters

Hour meters
Timers

Frequency displays
Tachometers

Position displays

Multifunction
devices

Energy meters

Process devices

Temperature
devices

Strain-gauge
controllers

Accessories
Index

Hour meters / timers, electromechanical

Timers for DIN rail mounting **Micro DIN rail housing (AC+DC)** **SHK 07.1**

Timer for DIN rail mount
Type SHK 07.1

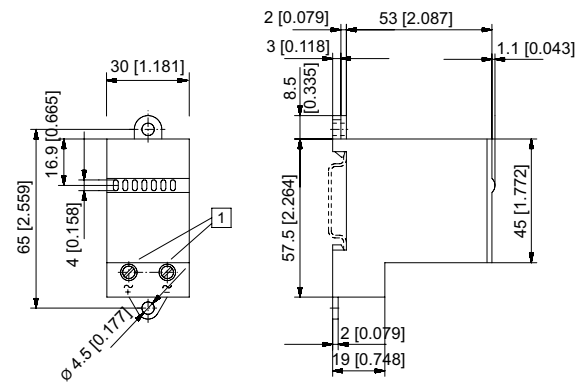

1) Electrical connection

Type	Display	Voltage	Art. no.			
			4.5 ... 35 V	20 ... 30 V	100 ... 130 V	187 ... 264 V
SHK 07.1	7 digits	AC (50...60 Hz)		3.102.101.310	3.102.101.312	3.102.101.313 ¹⁾
	7 digits	DC	3.102.101.383 ¹⁾			

Dimensions in mm [inch]

1) Stock types

- Product overview
- Basics
- Pulse counters
- Preset counters
- Hour meters
- Timers
- Frequency displays
- Tachometers
- Position displays
- Multifunction devices
- Energy meters
- Process devices
- Temperature devices
- Strain-gauge controllers
- Accessories
- Index

Timers for DIN rail mounting **DIN rail housing, 2 modules wide (AC+DC)** **SH 17**



The hour meters SH 17 feature a very high shock resistance.

These DIN rail mount counters can be used in many different fields of application. These non-resettable counters are extremely tamper-proof.

Characteristics

- 7-digit hour meter.
- DIN rail-mount housing, width 2 modules.
- High shock and impact resistance.
- Without reset.
- Magnified large figures.
- Protection IP65 on the front side.

Benefits

- Easy mounting.
- Data retention in case of power failure.
- Long service life.

Applications

General time measurement, maintenance intervals for measuring instruments, small appliances, UV lamps, integration in control cabinets.

Type series

Description	Mounting	Type
Standard timer	DIN rail 35 mm [1.38"] acc. to DIN EN 50022	SH 17

Technical data

Electrical connection		screw terminals
	finely-stranded	0 ... 2.5 mm ² [AWG13]
	single-wires	0 ... 4 mm ² [AWG11]
	tightening torque max.	0.5 Nm
Power consumption	DC	approx. 1 W
	AC	approx. 2.5 VA
Rated voltages		24, 115, 230 V AC ±10 %, 50Hz
		115 V AC ±10 %, 60Hz
		10 ... 27 V DC
On time		100 %
Number of digits		7: 99999.99 h
Height of figures		1.8 x 3.6 mm [0.071 x 0.14"]
Color of figures		white on black
Decimal figures		black on white
Housing		plastic PC (Polycarbonate)
Weight		approx. 60 g [2.12 oz]
Color of housing		grey, Ral 7035

Reset		no reset
Operating temperature	AC/DC	-10°C ... +70°C [+14°F ... +158°F] (non-condensing)
Storage temperature	AC/DC	-40°C ... +80°C [-40°F ... +176°F]
Mounting position		any
Protection acc. to EN 60529		IP65 (front side)
	screw terminal	IP20
Vibration resistance		1 g (10 ... 500 Hz) acc. to EN 60028-2-34
Shock resistance		30 g (18 ms) acc. to EN 60068-2-27
		25 g (6 ms) acc. to EN 60068-2-29
EMC standards		EN 55011 class B
		EN 61000-6-2, EN 61000-6-3
Device safety	designed to	EN 61010 part 1
	protection class	2
	application area	pollution level 2
Accuracy		< 0.01%, for all versions

Product overview
Basics

Pulse counters

Preset counters

Hour meters
Timers

Frequency displays
Tachometers

Position displays

Multifunction
devices

Energy meters

Process devices

Temperature
devices

Strain-gauge
controllers

Accessories
Index

Hour meters / timers, electromechanical

Timers for DIN rail mounting **DIN rail housing, 2 modules wide (AC+DC)** **SH 17**

Standard timer
Type SH 17

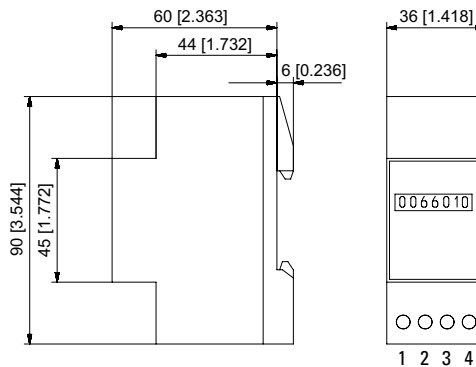

Terminal assignment

PIN	DC	AC
1	n.c.	n.c.
2	+	~
3	-	~
4	n.c.	n.c.

Type	Display	Voltage	Art. no.			
			24 V	115 V	230 V	10 ... 27 V DC
SH 17	7 digits	AC (50 Hz)	0.170.000.071	0.170.000.284	0.170.000.075 ¹⁾	
	7 digits	AC (60 Hz)		0.170.000.287		
	7 digits	DC				0.170.000.351 ¹⁾

Dimensions in mm [inch]

1) Stock types

- Product overview Basics
- Pulse counters
- Preset counters
- Hour meters Timers
- Frequency displays Tachometers
- Position displays
- Multifunction devices
- Energy meters
- Process devices
- Temperature devices
- Strain-gauge controllers
- Accessories Index

Hour meters / timers, electromechanical

Timers, round design	With LED run indicator (AC+DC)	HR 47
-----------------------------	---------------------------------------	--------------



The hour meter HR 47 with run indicator feature a very high shock resistance.

These panel-mount counters for round panel cut-outs can be used in many different fields of application. These non-resettable counters are very robust and extremely tamper-proof.

Characteristics

- 7-digit hour meter.
- For voltage ranges 10 ... 80 V DC, 100 ... 130 V AC and 187 ... 264 V AC.
- Magnified large figures.
- Protection IP65 on the front and rear sides.
- Suitable for any mounting position.
- Without reset, and thus tamper-proof.
- High shock and impact resistance.

Benefits

- With run indicator (AC version), optional LED (DC version).
- For panel cut-out \varnothing 50.5 mm with front panel dimensions \varnothing 58 mm.
- Simple and secure mounting with screwed clamping clip.

Applications

General time measurement, construction machinery and industrial trucks, small appliances, UV lamps, display panels in vehicles, compressors, air-conditioning equipment, etc..

Type series

Description	Mounting	Type
Timer, round	Clamping clip fixing, screw-on	HR 47

Accessories	Dimensions in mm [inch]	Order no.
Counter mounting fixture	for round counters with cut-out \varnothing 53 [2.09"]	black N510199
Gasket, \varnothing 58 [2.28"]	for cut-out \varnothing 50 [1.97"]	black N511182
Adapter and anti-vibration set	for HR 47, \varnothing 80 [3.15"] for cut-out \varnothing 71 [2.80"]	black 255319

Suitable gaskets as well as further accessories can be found in the accessories section or in the accessories area of our website at: www.kuebler.com/accessories.

Product overview
Basics

Pulse counters

Preset counters

Hour meters
Timers

Frequency displays
Tachometers

Position displays

Multifunction
devices

Energy meters

Process devices

Temperature
devices

Strain-gauge
controllers

Accessories
Index

Hour meters / timers, electromechanical

Timers, round design With LED run indicator (AC+DC) HR 47

Technical data	
Electrical connection	screw terminal for flat pin 6.3 x 0.8 mm [0.25 x 0.031"]
Power consumption	10 ... 80 V DC max. 720 mW 100 ... 130 V AC, 60 Hz max. 1.1 VA 187 ... 264 V AC, 50 Hz approx. 1.2 VA
Rated voltages	AC (50 or 60 Hz) 100 ... 130/187 ... 264 V AC, DC 10 ... 80 V DC
On time	100 %
Number of digits	AC 7: 99999.99 h DC 7: 999999.9 h
Resolution	AC 0.01 h equals 36 s DC 0.1 h equals 6 min
Count mode	adding
Height of figures	4 mm [0.16"]
Color of figures	hours white on black decimal position 50 Hz - red on black 60 Hz - red on white
Count position at delivery	1.00 - 1.02
Operating temperature	AC -25°C ... +80°C [-13°F ... +176°F] (non-condensing) DC -20°C ... +70°C [-4°F ... +158°F] (non-condensing)
Relative humidity	< 95 % (non-condensing)

Mounting position	any
Protection	IP65, EN 60529 (except the connections)
Housing	plastic PC (Polycarbonate)
Accuracy	AC ±0.02 % DC ±0.002 %
Weight	approx. 50 g [1.76 oz]
Run indicator	AC fast rotating wheel in viewing window DC optional LED
Test voltage	2000 V AC, 50 Hz for AC version
EMC standards	EN 55011 class B EN 61000-6-2, EN 61000-6-3
Device safety	designed to EN 61010 part 1 protection class 2 application area pollution level 2

Options	
Counter for ø 52 mm [0.20"] with screwed clamping bracket or screw thread on request	

Timer, round Type HR 47

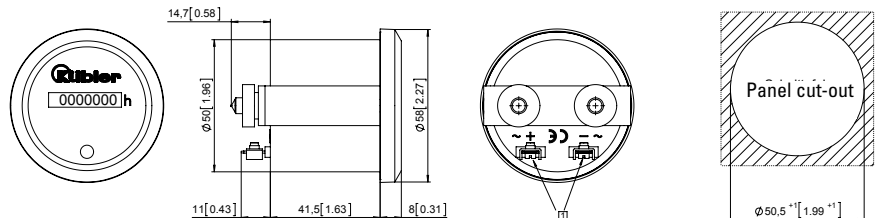

1) Electrical connection: +/~ left, -/~ right (rear view)

Front bezel thickness max. 6 [0.24] without having to shorten the clamping bracket

Type	Display	Voltage	Art. no.			
			10 ... 80 V DC	100 ... 130 V 60 Hz	187 ... 264 V 50 Hz	
HR 47	7 digits	V AC, with run indicator		3.474.901.084 ¹⁾	3.474.901.075 ¹⁾	further types on request
	7 digits	V DC, without run indicator	3.474.901.373 ¹⁾			
	7 digits	V DC, with run indicator	3.474.911.373 ¹⁾			

Hour meters / timers, electromechanical

Timers, round design	High protection rating (AC+DC)	HR 76
-----------------------------	---------------------------------------	--------------



The hour meter HR 76 feature a very high shock resistance.

These panel-mount counters for round panel cut-outs can be used in many different fields of application. These non-resettable counters are very robust and extremely tamper-proof.

Characteristics

- 6-digit hour meter.
- Low cost.
- High shock resistance.
- Low energy consumption.
- Magnified large figures.
- Protection IP65.
- Data retention in case of power failure.
- Long service life.

Benefits

- 50/60 Hz in the same device.
- Small mounting depth.
- Waterproof on the front and on the rear.

Applications

Operating hours measurement with construction and agricultural machinery, compressors, power units.

Type series

Description	Mounting	Type
Timer, round	screw mounting front side	HR 76.1
Timer, round	clip mounting	HR 76.2

Accessories	Dimensions in mm [inch]	Order no.
Counter mounting fixture	for round counters with cut-out \varnothing 53 [2.09"]	black N510199

Suitable gaskets as well as further accessories can be found in the accessories section or in the accessories area of our website at: www.kuebler.com/accessories.

Technical data	
Electrical connection	flat pin 0.8 x 6.3 mm [0.031 x 0.25"]
Power consumption	AC max. 0.4 VA 12 V DC max. 0.08 W 48 V DC max. 0.7 W
Rated voltages	AC (50 or 60 Hz) 115/230 V AC, \pm 10 %, 50/60 Hz DC 10 ... 80 V DC
On time	100 %
Number of digits	6: 99999.9 h
Count mode	adding
Height of figures	3.5 mm [0.14"] heigh
Color of figures	white on black
Reset	no reset

Operating temperature	-30°C ... +65°C [-22°F ... +185°F] (non-condensing)
Storage temperature	-40°C ... +85°C [-40°F ... +149°F]
Mounting position	any
Protection	IP65 (except the connections)
Housing	plastic PC (Polycarbonate)
Accuracy	< 0.02 % over the full range
Weight	HR 76.1 56 g [1.98 oz] HR 76.2 54 g [1.91 oz]
EMC standards	EN 55011 class B EN 61000-6-2, EN 61000-6-3 EN 61326-1
Device safety	designed to EN 61010 part 1 protection class 2 application area pollution level 2
UL approval	file E128604

Hour meters / timers, electromechanical

Timers, round design **High protection rating (AC+DC)** **HR 76**

Timer, round screw mounting front side
Type HR 76.1

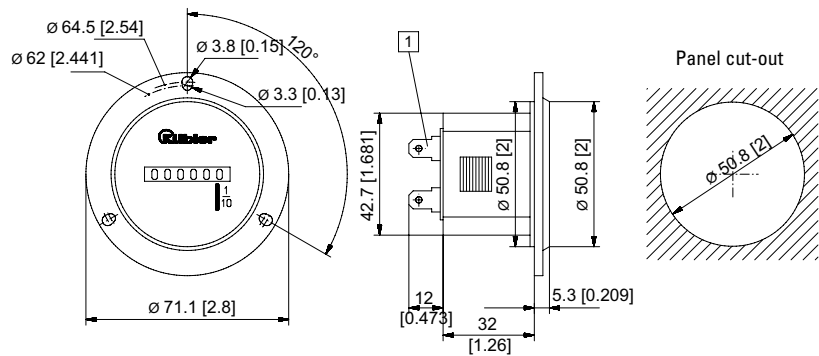

1) Electrical connection: flat pin 0.8 x 6.3 [0.031 x 0.25]

Type	Display	Voltage	Art. no.			
			10 ... 80 V DC	115 V	230 V	
HR 76.1	6 digits	AC (50/60 Hz)		0.135.100.301 ¹⁾	0.135.100.302 ¹⁾	Gasket for front bezel N511150 not included in delivery
	6 digits	DC	0.135.100.373 ¹⁾			

Timer, round clip mounting
Type HR 76.2

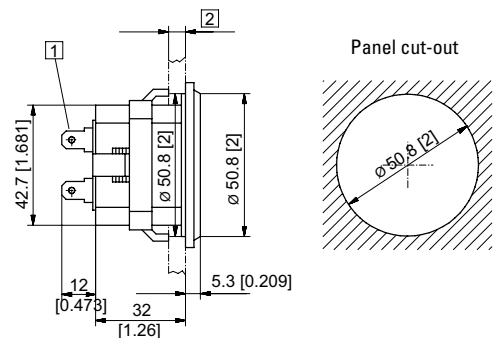
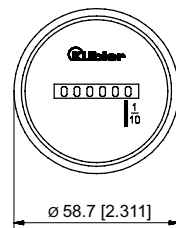

For mounting the counter onto a flat plate, see accessories chapter
Art. no.: N510199

1) Electrical connection: flat pin 0.8 x 6.3 [0.031 x 0.25] 2) max. 9 [035]

Type	Display	Voltage	Art. no.			
			10 ... 80 V DC	115 V	230 V	
HR 76.2	6 digits	AC (50/60 Hz)		0.135.200.301 ¹⁾	0.135.200.302 ¹⁾	Gasket integrated in counter
	6 digits	DC	0.135.200.373 ¹⁾			

Hour meters / timers, electromechanical

Standard timers	9999.99 h / 99999.9 h with reset (AC+DC)	HB 26
------------------------	---	--------------



The timer HB 26 with reset measure time ranges up to max. 99999.9 h or 9999.99 h.

These panel-mount counters can be used in many different fields of application.

Characteristics

- 6-digit hour meter without reset.
- High shock and impact resistance.
- Magnified large figures; height 4.5 mm.
- Data retention in case of power failure.
- Long service life.
- Plug-in versions.
- Counter without front bezel for mounting in front bezel F1B and F2B and for combination in 50 x 25 mm size with socket box 945.2.

Benefits

- Can be combined with preset counters BVa and HVa, and with pulse counter B.
- Can be equipped with various sealing covers to protect the counter against dust, dirt and moisture.
- Key-locking 0-reset.

Applications

General time measurement, maintenance intervals for measuring instruments (respiration units, oxygen, dialysis), small appliances, UV lamps, display panels in vehicles.

Type series

Description

- Screw mounting, 56 x 40 mm [2.20 x 1.57"]
- Clip mounting, 53 x 28 mm [2.09 x 1.10"]
- Plug-in for socket box 945.2 and front bezel F1B

Type

- HB 26.11**
- HB 26.21**
- HB 26.01.3**

Options

- Different voltages
- Extended temperature range on request
- Flat pin 0.8 x 6.3 mm [0.031 x 0.25"] without flat push on connectors: Art.-Nr. 3.168.X11.XXX
- Flat pin 0.8 x 2.8 mm [0.031 x 0.11"] with flat push on connectors: Art.-Nr. 3.167.X11.XXX
- Lockable 0-reset: Art.-Nr. 3.160.XX7.XXX
The button can be unlocked by means of the key



Product overview
Basics

Pulse counters

Preset counters

Hour meters
Timers

Frequency displays
Tachometers

Position displays

Multifunction
devices

Energy meters

Process devices

Temperature
devices

Strain-gauge
controllers

Accessories
Index

Hour meters / timers, electromechanical

Standard timers	9999.99 h / 99999.9 h with reset (AC+DC)	HB 26	
Accessories	Dimensions in mm [inch]		Order no.
Front bezel, type F1B plastic	for cut-out 54 x 49 [2.13 x 1.93], for screw mounting, for plug-in counters B1x.0x and HB2x.0x in socket box type 945.2	beige black	G007501 G007502
Socket box, type 945.2	for counters B1x.0x and HB2x.0x, can be used for plug-in connections in front bezel F1B	black	G008434
Sealing cover, type K1, IP65	for front bezel 60 x 50 [2.36 x 1.97], with screw mounting, for electromechanical counters and via adapter front bezel N003001 for counters 48 x 24 [1.89 x 0.94]	transparent / grey transparent / black	G008300 G008301
Transparent cover, lockable, IP65	for cut-out 54 x 29 [2.13 x 1.14], for screw mounting to front bezel F1B or adapter front bezel N003001, for counters with cut-out 50 x 25 [1.97 x 0.98] or 45 x 22.2 [1.77 x 0.87]		N003002
Blind enclosure, 53 x 28 [2.07 x 1.10]	for cut-out 50 x 25 [1.97 x 0.98], for counters 53 x 28 [2.09 x 1.10]	black	T005753
Mounting frame with cut-out 50 x 25 [2.36 x 1.97] via separate adapter also for 45 x 22.2 [1.77 x 0.87]	for snap-on mounting on 35 [1.38] top-hat DIN rail, for counters 53 x 28 [2.09 x 1.10] and via separate adapter (T008180) for counters 48 x 24 [1.89 x 0.94]	chromated	G300004
Mounting rail frame SR	for B and HB counters for snap-on mounting on 35 [1.38] top-hat DIN rail	SR 1 for 1x3 B counters SR 2 for 2x3 B counters	G300000 G300001

Suitable gaskets, other accessories and installation examples for optional accessories can be found in chapter accessories or in the accessories section under: www.kuebler.com/accessories.

Technical data

Electrical characteristics		General technical data	
Electrical connection	cable 2 x 0.5 mm ² [AWG20], NYFAZ, 0.5 m [1.64'] long AC: grey/grey, DC: red +, black - type HB 26.01.3 round pins ø 1.6 mm [0.063"] (plugs into socket box type 945.2)	Display	number of digits 6, AC: 9999.99 h, DC: 99999.9 h height of figures 4.5 mm [0.17"] color of figures white and red on black
Power consumption	10 ... 30 V DC approx. 500 mW 36 ... 80 V DC approx. 900 mW 100 ... 130 V DC approx. 750 mW 20 ... 30 V AC approx. 0.3 VA 42 ... 48 V AC approx. 0.25 VA 100 ... 130 V AC approx. 0.6 VA 187 ... 264 V AC approx. 1.2 VA 360 ... 440 V AC approx. 1.65 VA	Operating temperature	-15°C ... +50°C [+5°F ... +122°F] (non-condensing)
Rated voltages	AC (50 or 60 Hz) 20 ... 30 / 42 ... 48 / 100 ... 130 / 187 ... 264 / 360 ... 440 V AC DC 10 ... 30 / 36 ... 80 / 100 ... 130 V DC	Mounting position	any
Accuracy	AC supply frequency + 30 ms DC < 0.003 % (at 24 h)	Mechanical characteristics	
EMC standards	EN 55011 class B EN 61000-6-2, EN 61000-6-3	Housing	plastic PC (Polycarbonate)
Device safety	designed to EN 61010 part 1 protection class 2 application area pollution level 2	Protection	IP41 (front side) with flexible sealing cover K1 IP54 (front side) with transparent cover Dv., Dvs IP55 (front side)
		Weight	approx. 45 g [1.59 oz]
		Options	
		Different voltages and extended temperature range on request	
		Flat pin 0.8 x 6.3 mm [0.031 x 0.25"] without flat push on connectors	Art. no. 3.168.X11.XXX
		Flat pin 0.8 x 2.8 mm [0.031 x 0.11"] with flat push on connectors	Art. no. 3.167.X11.XXX
		Key-locking 0-reset	Art. no. 3.160.XX7.XXX

Hour meters / timers, electromechanical

Standard timers **9999.99 h / 99999.9 h with reset (AC+DC)** **HB 26**

Screw mounting, 56 x 40 [2.20 x 1.57]
Type HB 26.11

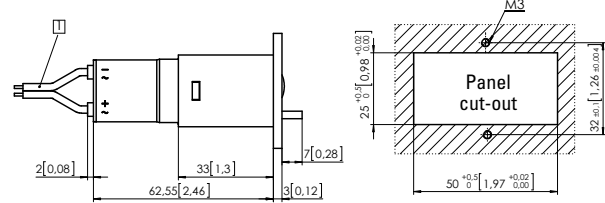
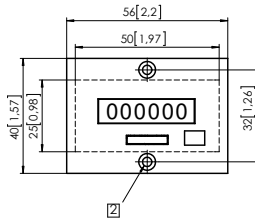

1) Connection cable, 2 x 0.5 mm² [AWG20], NYFAZ, 0.5 m [1.64'] long 2) Countersinking Af3, DIN 74

Type	Display	Voltage	Art. no.						
			10 ... 30 V	20 ... 30 V	36 ... 80 V	42 ... 48 V	100 ... 130 V	187 ... 264 V	360 ... 440 V
HB 26.11	6 digits	AC (50 Hz)		3.160.111.071		3.160.111.072	3.160.111.074	3.160.111.075 ¹⁾	3.160.111.079
	6 digits	AC (60 Hz)		3.160.111.081		3.160.111.082	3.160.111.084	3.160.111.085	3.160.111.089
	6 digits	DC	3.160.111.351 ¹⁾		3.160.111.353		3.160.111.381		

Clip mounting, 53 x 28 [2.09 x 1.10]
Type HB 26.21

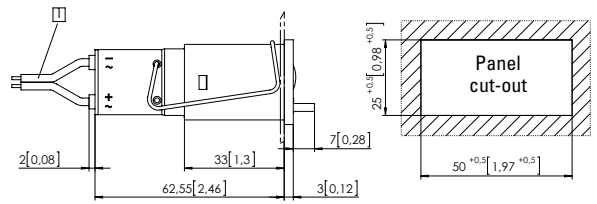
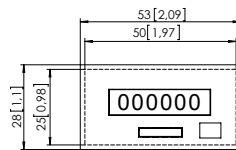

1) Connection cable, 2 x 0.5 mm² [AWG20], NYFAZ, 0.5 m [1.64'] long

Type	Display	Voltage	Art. no.						
			10 ... 30 V	20 ... 30 V	36 ... 80 V	42 ... 48 V	100 ... 130 V	187 ... 264 V	360 ... 440 V
HB 26.21	6 digits	AC (50 Hz)		3.160.211.071		3.160.211.072	3.160.211.074	3.160.211.075 ¹⁾	3.160.211.079
	6 digits	AC (60 Hz)		3.160.211.081		3.160.211.082	3.160.211.084	3.160.211.085	3.160.211.089
	6 digits	DC	3.160.211.351 ¹⁾		3.160.211.353		3.160.211.381		
Further stock types:			187... 264 V AC, key lockable reset			3.160.217.075			
			187... 264 V AC, flat pin 0.8 x 2.8 mm [0.031 x 0.11"]			3.167.211.075			
			10 ... 30 V DC, flat pin 0.8 x 2.8 mm [0.031 x 0.11"]			3.167.211.351			

Hour meters / timers, electromechanical

Standard timers	9999.99 h / 99999.9 h with reset (AC+DC)	HB 26
------------------------	---	--------------

Plug-in for socket box 945.2 and front bezel F1B
Type HB 26.01.3

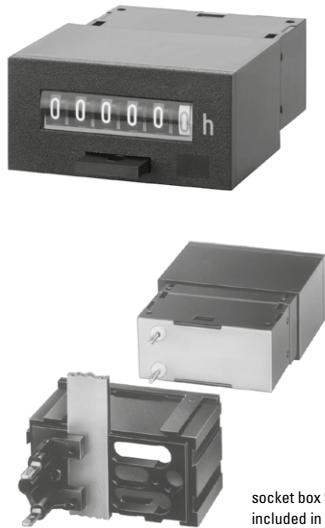

socket box 945.2 not included in delivery

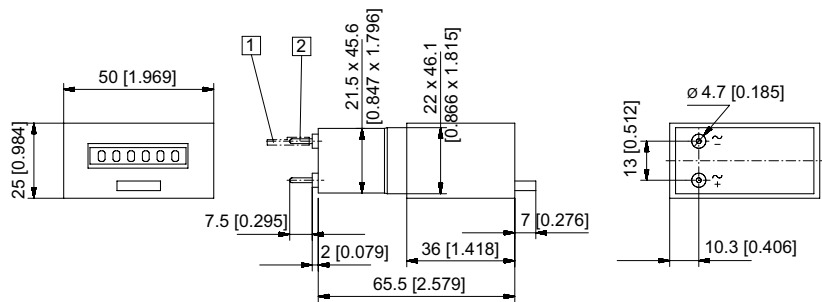

- 1 Push on connector \varnothing 1.5 [0.059] tinned 2 Round pin \varnothing 1.6 [0.063] tinned

Type	Display	Voltage	Art. no.						
			10 ... 30 V	20 ... 30 V	36 ... 80 V	42 ... 48 V	100 ... 130 V	187 ... 264 V	360 ... 440 V
HB 26.01.3	6 digits	AC (50 Hz)		3.165.011.071		3.165.011.072	3.165.011.074	3.165.011.075	3.165.011.079
	6 digits	AC (60 Hz)		3.165.011.081		3.165.011.082	3.165.011.084	3.165.011.085	3.165.011.089
	6 digits	DC	3.165.011.351		3.165.011.353		3.165.011.381		

Mounting examples for optional accessories

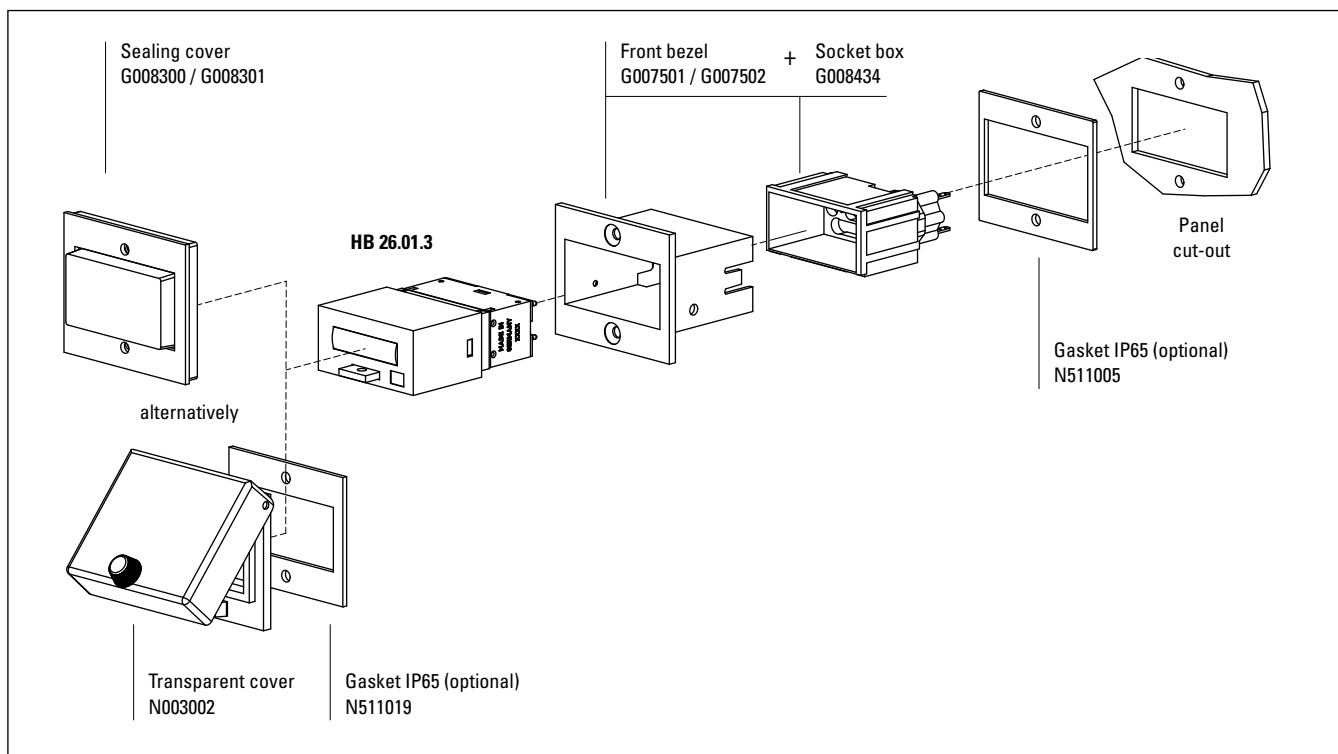

Dimensions in mm [inch]

Product overview
Basics
Pulse counters
Preset counters
Hour meters
Timers
Frequency displays
Tachometers
Position displays
Multifunction devices
Energy meters
Process devices
Temperature devices
Strain-gauge controllers
Accessories
Index

Hour meters / timers, electromechanical

Standard timers	99999.99 h (AC) / 999999.9 h (DC) without reset	HB 27
------------------------	--	--------------



The timers HB 27 without reset measure time ranges up to max. 99999.99 h (AC) or 999999.9 h (DC).

These panel mount counters can be used in many different fields of application.

Characteristics

- 7-digit hour meter without reset.
- High shock and impact resistance.
- Magnified large figures; height 4.5 mm.
- Data retention in case of power failure.
- Long service life.
- Plug-in versions.
- Counter without front bezel for mounting in front bezel F1B and F2B and for combination in 50 x 25 mm size with socket box 945.2.

Benefits

- Can be combined with preset counters BVa and HVa, and with pulse counter B.
- Can be equipped with various sealing covers to protect the counter against dust, dirt and moisture.
- Tamper-proof.

Applications

General time measurement, maintenance intervals for measuring instruments (respiration units, oxygen, dialysis), small appliances, UV lamps, display panels in vehicles.

Type series

Description	Type	Options
Plug-in for socket box 945.2 945.2 and front bezel F1B	HB 27.00.3	<ul style="list-style-type: none"> • Different voltages / extended temperature range on request • Flat pin 0.8 x 6.3 mm [0.031 x 0.25"] without flat push on connectors: Art. no. 3.208.X11.XXX • Flat pin 0.8 x 2.8 mm [0.031 x 0.11"] with flat push on connectors: Art. no. 3.207.X01.XXX • Round pins ø 1.5 mm (tinned) with push on connectors Art. no. 3.205.X01.XX
Screw mounting 56 x 40 mm [2.20 x 1.57"]	HB 27.10	
Clip mounting 53 x 28 mm [2.09 x 1.10"]	HB 27.20	

Accessories	Dimensions in mm [inch]	Order no.
Front bezel, type F1B plastic	For cut-out 54 x 49 [2.13 x 1.93], with screw mounting, for plug-in counters B1x.0x and HB2x.0x in socket box type 945.2	beige black G007501 G007502
Socket box, type 945.2	For counters B1x.0x and HB2x.0x, can be used for plug-in connections in front bezel F1B	black G008434
Sealing cover, type K1, IP65	For front bezel 60 x 50 [2.36 x 1.97], with screw mounting, for electromechanical counters and via adapter front bezel N003001 for counters 48 x 24 [1.89 x 0.94]	transparent / grey transparent / black G008300 G008301
Transparent cover, lockable, IP65	For cut-out 54 x 29 [2.13 x 1.14], with screw mounting to front bezel F1B or adapter front bezel N003001, for counters with cut-out 50 x 25 [1.97 x 0.98"] or 45 x 22.2 [1.77 x 0.87]	transparent / black N003002
Blind enclosure, 53 x 28 [2.09 x 1.10]	For cut-out 50 x 25 [1.97 x 0.98], for counters 53 x 28 [2.09 x 1.10]	black T005753
Mounting frame with cut-out 50 x 25 [1.97 x 1.97] via separate adapter also for 45 x 22.2 [1.77 x 0.87]	For snap-on mounting on 35 [1.38] top-hat DIN rail, for counters 53 x 28 [2.09 x 1.10] and via separate adapter (T008180) for counters 48 x 24 [1.89 x 0.94]	chromated G300004
Mounting rail frame SR	For B and HB counters for snap-on mounting on 35 [1.38] top-hat DIN rail	SR 1 for 1x3 B counters SR 2 for 2x3 B counters G300000 G300001

Suitable gaskets, other accessories and installation examples for optional accessories can be found in chapter accessories or in the accessories section under: www.kuebler.com/accessories.

Hour meters / timers, electromechanical

Standard timers	99999.99 h (AC) / 999999.9 h (DC) without reset	HB 27
------------------------	--	--------------

Technical data

General technical data	
Display	7 digits AC 99999.99 h DC 999999.9 h
Height of figures	4.5 mm [0.17"]
Color of figures	white and red on black
Operating temperature	-15°C ... +50°C [+5°F ... +122°F] (non-condensing)
Mounting position	any

Mechanical characteristics	
Protection	up to IP51 (front side) with sealing cover K1 IP54 (front side) with transparent cover Dv, Dvs IP55 (front side)
Housing	plastic PC (Polycarbonate)
Weight	approx. 45 g [1.59 oz]

Electrical characteristics		
Electrical connection	cable	2 x 0.5 mm ² [AWG20], NYFAZ, 0.5 m [1.64'] long AC: grey/grey DC: red +, black - type HB 27.00.3 round pins ø 1.6 mm [0.063"] (plugs into socket box type 945.2)
Test voltage		2000 V AC, 50 Hz for AC counters
Power consumption	10 ... 30 V DC 36 ... 80 V DC 100 ... 130 V DC 20 ... 30 V AC 42 ... 48 V AC 100 ... 130 V AC 187 ... 264 V AC 360 ... 440 V AC	approx. 500 mW approx. 900 mW approx. 750 mW approx. 0.3 VA approx. 0.25 VA approx. 0.6 VA approx. 1.2 VA approx. 1.65 VA
Rated voltages	AC (50 or 60 Hz) DC	20 ... 30 / 42 ... 48 / 100 ... 130 / 187 ... 264 / 360 ... 440 V AC 10 ... 30 / 36 ... 80 / 100 ... 130 V DC
Accuracy	AC DC	supply frequency + 30 ms < 0.003 % (at 24 h)
EMC standards		EN 55011 class B EN 61000-6-2, EN 61000-6-3
Device safety	designed to protection class application area	EN 61010 part 1 2 pollution level 2

Plug-in for socket box 945.2 and front bezel F1B
Type HB 27.00.3

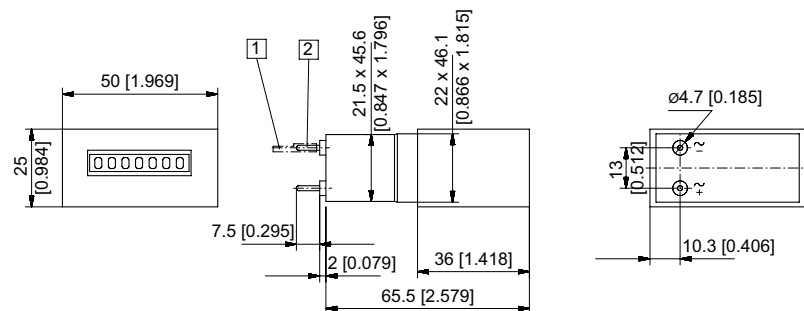

1 Push on connector ø 1.5 [0.059] tinned 2 Round pin ø 1.6 [0.063] tinned

Type	Display	Voltage	Art. no.						
			10 ... 30 V	20 ... 30 V	36 ... 80 V	42 ... 48 V	100 ... 130 V	187 ... 264 V	360 ... 440 V
HB 27.00.3	7 digits	AC (50 Hz)		3.205.001.071		3.205.001.072	3.205.001.074	3.205.001.075	3.205.001.079
	7 digits	AC (60 Hz)		3.205.001.081		3.205.001.082	3.205.001.084	3.205.001.085	3.205.001.089
	7 digits	DC	3.205.001.351		3.205.001.353		3.205.001.381		

Hour meters / timers, electromechanical

Standard timers **99999.99 h (AC) / 999999.9 h (DC) without reset** **HB 27**

Screw mounting 56 x 40 [2.20 x 1.57]
Type HB 27.10

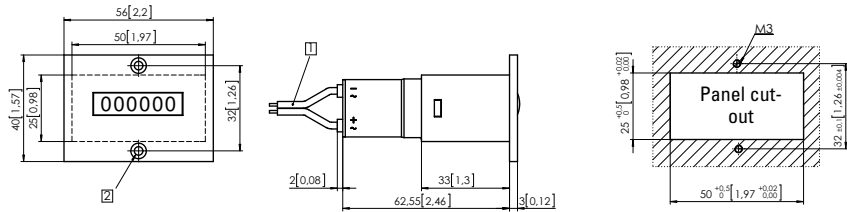
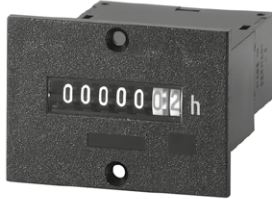

1) Connection cable, 2 x 0.5 mm² [AWG20], NYFAZ, 0.5 m [1.64'] long 2) Countersinking Af3, DIN 74

Type	Display	Voltage	Art. no.						
			10 ... 30 V	20 ... 30 V	36 ... 80 V	42 ... 48 V	100 ... 130 V	187 ... 264 V	360 ... 440 V
HB 27.10	7 digits	AC (50 Hz)		3.200.101.071		3.200.101.072	3.200.101.074	3.200.101.075	3.200.101.079
	7 digits	AC (60 Hz)		3.200.101.081		3.200.101.082	3.200.101.084	3.200.101.085	3.200.101.089
	7 digits	DC	3.200.101.351		3.200.101.353		3.200.101.381		

Clip mounting 53 x 28 [2.09 x 1.10]
Type HB 27.20

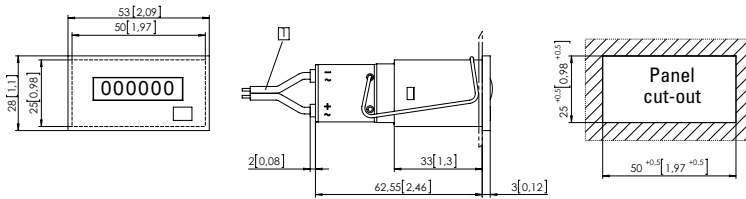

1) Connection cable, 2 x 0.5 mm² [AWG20], NYFAZ, 0.5 m [1.64'] long

Type	Display	Voltage	Art. no.						
			10 ... 30 V	20 ... 30 V	36 ... 80 V	42 ... 48 V	100 ... 130 V	187 ... 264 V	360 ... 440 V
HB 27.20	7 digits	AC (50 Hz)		3.200.201.071		3.200.201.072	3.200.201.074	3.200.201.075	3.200.201.079
	7 digits	AC (60 Hz)		3.200.201.081		3.200.201.082	3.200.201.084	3.200.201.085	3.200.201.089
	7 digits	DC	3.200.201.351		3.200.201.353		3.200.201.381		
Further stock types:			187... 264 V AC, flat pin 0.8 x 2.8 mm [0.031 x 0.11"]			3.207.201.075			

Hour meters / timers, electromechanical

Standard timers **99999.99 h (AC) / 999999.9 h (DC) without reset** **HB 27**

Mounting examples for optional accessories

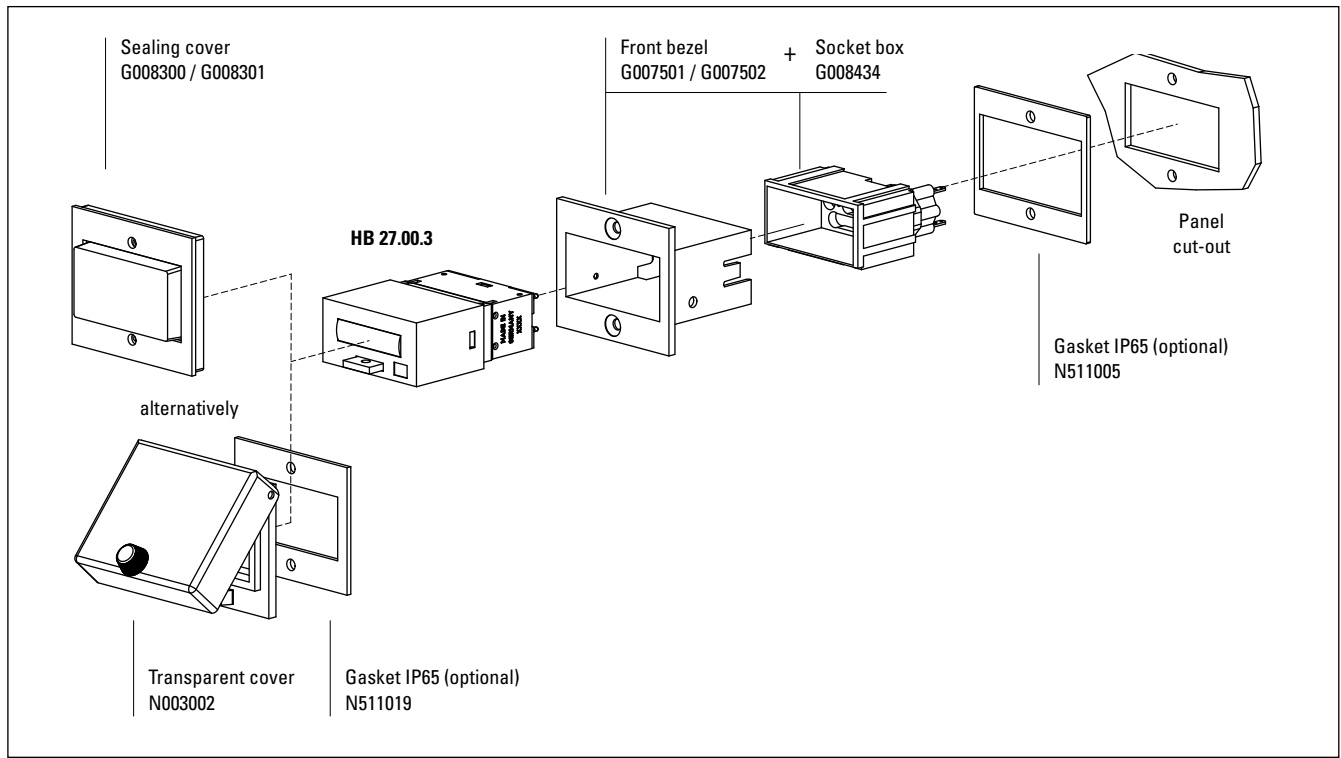

- Product overview
- Basics
- Pulse counters
- Preset counters
- Hour meters
- Timers
- Frequency displays
- Tachometers
- Position displays
- Multifunction devices
- Energy meters
- Process devices
- Temperature devices
- Strain-gauge controllers
- Accessories
- Index

Dual function counters

Pulse + time / 2 x time (AC+DC)

HC 77



The counter combinations HC 77 and HC 77.55 comprise an hour meter and a totalizer. They can be controlled both simultaneously and separately.

These panel mount counters have a reduced mounting depth. They can be used in many different fields of application.

Optionally with 2 hour meters on request.

Characteristics

- Hour meter and totalizer in one single device.
- Without reset.
- High shock resistance.
- Magnified large figures.
- Protection IP52 front side (optional IP65).
- Data retention in case of power failure.
- UL-approved.

Benefits

- Long service life.
- Optional: counters controlled separately.

Applications

General time measurement, maintenance intervals for measuring instruments (respiration units, oxygen, dialysis), small appliances, UV lamps, display panels in vehicles, lifts, heating burners.

Type series

Description	Type	Options
Dual function counter 48 x 48 mm [1.89 x 1.89"]	HC 77	<ul style="list-style-type: none"> - Color of housing grey Art. no. 3.55X.400.XXX - Flat pin 0.8 x 6.3 mm [0.031 x 0.25"] Art.-No.: 3.55X.40X.XXX.011
With adapter front bezel 55 x 55 mm [2.17 x 2.17"]	HC 77.55	<ul style="list-style-type: none"> - Separate connections for running time meter and adding counter. This model is available for AC or DC (not mixed) - Adding counter max. 10 Hz - Electrical connection: 2 x cable 2 x 0.5 mm² [AWG20], NYFAZ, 0.5 m [1.64'] (hour meter cable red/black, adding counter grey cable) Art. no. 3.55X.40X.XXX.060 - Sealed window (IP65 front side) with: <ul style="list-style-type: none"> - Screw terminal Art. no. 3.55X.40X.XXX.419 - Flat pin 0.8 x 6.3 mm [0.031 x 0.25"] Art. no. 3.55X.40X.XXX.062 - Separated connections (cable) Art. no. 3.55X.40X.XXX.061 - Counter combination with 2 hour meters 10 ... 30 V DC <ul style="list-style-type: none"> - 2 x cable 2 x 0.5 mm² [AWG20] Art. no. 3.554.401.351.060 - Spring-type terminal on request

Accessories

Accessories	Dimensions in mm [inch]	Order no.
Adapter front bezel, 55 x 55 [2.17 x 2.17"]	for cut-out 50 x 50 [1.97 x 1.97] to cut-out ø 50.5 [1.99], with clip mounting for counters 48 x 48 [1.89 x 1.89]	black T008171
Adapter front bezel, 60 x 75 [2.36 x 2.95"]	for cut-out 50 x 50 [1.97 x 1.97] to cut-out 45 x 45 [1.7 x 1.77], with screw mounting for counters 48 x 48 [1.89 x 1.89]	black T008860
Adapter front bezel, 72 x 72 [2.83 x 2.83"]	for cut-out 68 x 68 [2.68 x 2.68] to cut-out 45 x 45 [1.7 x 1.77], (Mating clip T009420 must be ordered separately)	black T008177
Adapter front bezel, ø 72 [2.83"]	for cut-out ø 60 [2.36] to 45 x 45 [1.77 x 1.77], with clip mounting for counters 48 x 48 [1.89 x 1.89]	black N510226

Suitable gaskets as well as further accessories can be found in the accessories section or in the accessories area of our website at: www.kuebler.com/accessories.

Hour meters / timers, electromechanical

Dual function counters	Pulse + time / 2 x time (AC+DC)	HC 77
-------------------------------	--	--------------

Technical data

General technical data		
Operating indicator of the running time meter	AC	fast rotating wheel with red dashes: 99999.99 h
	DC	1/100 h display turns continuously by 1 digit in 36 s: 999999.99 h
Height of figures	4 x 1.7 mm [0.16 x 0.067"] optical	
Color of figures	hour meter	hour: white on black decimal: red on black
	pulse counter	white on black
Operating temperature	-15°C ... +50°C [+5°F ... +122°F] (non-condensing)	
Mounting position	any	

Mechanical characteristics		
Protection	IP52 (front side) when built in	
Color of housing	black (standard)	
Weight	HC 77	65 g [2.29 oz]
	plug in frame 55	8 g [0.28 oz]
	plug in frame 72	13 g [0.46 oz]

Electrical characteristics		
Electrical connection	screw terminal (tightening torque max. 0.8 Nm)	
Power consumption	10 ... 30 V DC	approx. 1 W
	36 ... 80 V DC	approx. 1.65 W
	100 ... 130 V DC	approx. 1.75 W
	20 ... 30 V AC, 50 Hz	approx. 0.53 VA
	42 ... 48 V AC, 50 Hz	approx. 0.53 VA
	100 ... 130 V AC, 50 Hz	approx. 1.43 VA
Rated voltages	AC (50 or 60 Hz)	20 ... 30/42 ... 48/100 ... 130/187 ... 264 V
	DC	10 ... 30/36 ... 80/100 ... 130 V
On time	100 %	
Count mode	adding	
Accuracy	AC	supply frequency + 30 ms
	DC	< 0.003 % (at 24 h)
Reset	no reset	
EMC standards	EN 55011 class B EN 61000-6-2, EN 61000-6-3	
Device safety	designed to protection class	EN 61010 part 1
	application area	2 pollution level 2
UL approval	file E128604	

Terminal assignment

Counter with separate connections (rear view)

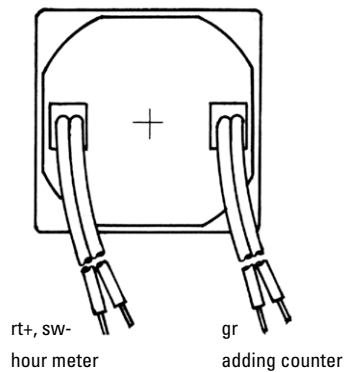

Hour meters / timers, electromechanical

Dual function counters

Pulse + time / 2 x time (AC+DC)

HC 77

Dual function counter 48 x 48 [1.89 x 1.89"]

Type HC 77

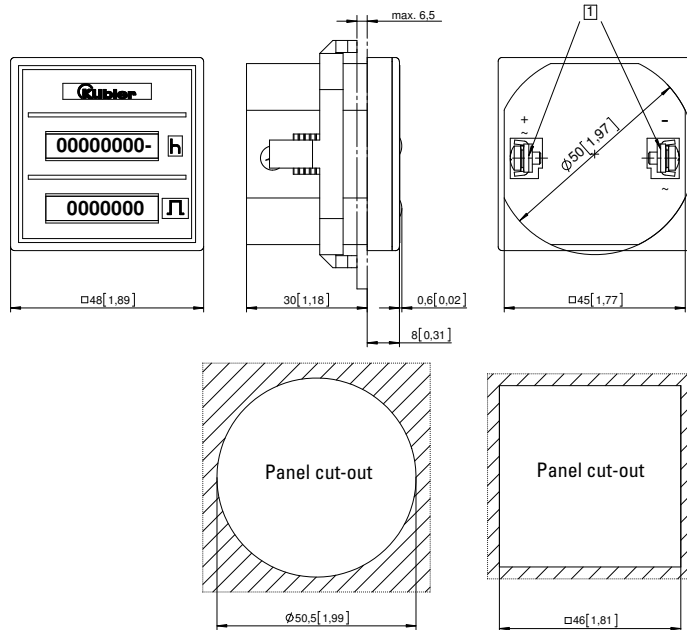

1 Screw terminal with flat pin
0.8 x 6.3 [0.031 x 0.25]

Type	Display	Voltage	Art. no.					
			10 ... 30 V	20 ... 30 V	36 ... 80 V	42 ... 48 V	100 ... 130 V	187 ... 264 V
HC 77	7/8 digits	AC (50 Hz)		3.550.401.071		3.550.401.072	3.550.401.074 ¹⁾	3.550.401.075 ¹⁾
	7/8 digits	AC (60 Hz)		3.550.401.081		3.550.401.082	3.550.401.084	3.550.401.085
	7/8 digits	DC	3.550.401.351 ¹⁾		3.550.401.353		3.550.401.381	
Color of housing grey:			Art. no.		3.550.400.XXX			

Dual function counter 48 x 48 [1.89 x 1.89"] with adapter front bezel 55 x 55 [2.17 x 2.17"]

Type HC 77.55

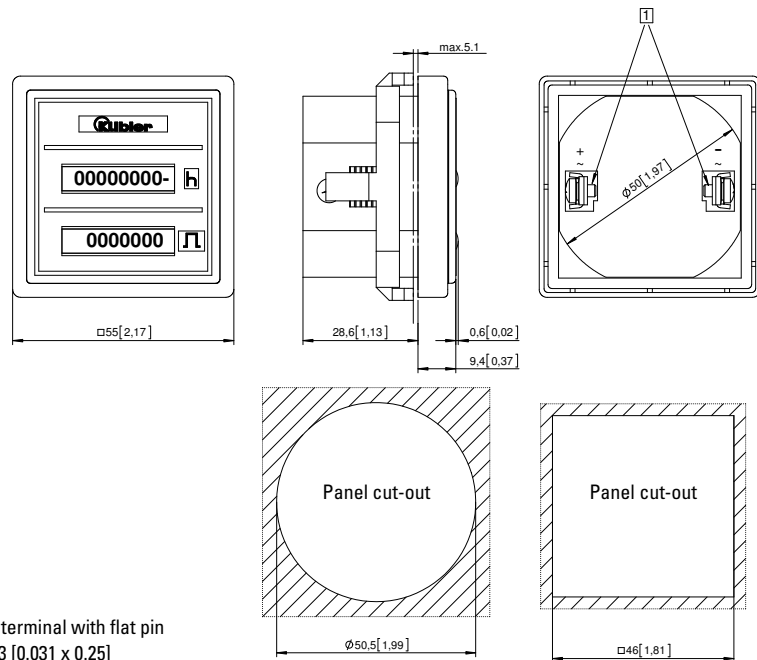

1 Screw terminal with flat pin
0.8 x 6.3 [0.031 x 0.25]

Type	Display	Voltage	Art. no.					
			10 ... 30 V	20 ... 30 V	36 ... 80 V	42 ... 48 V	100 ... 130 V	187 ... 264 V
HC 77.55	7-/8 digits	AC (50 Hz)		3.551.401.071		3.551.401.072	3.551.401.074	3.551.401.075
	7/8 digits	AC (60 Hz)		3.551.401.081		3.551.401.082	3.551.401.084	3.551.401.085
	7/8 digits	DC	3.551.401.351		on request		3.551.401.381	
Color of housing grey:			Art. no.		3.551.400.XXX			

Dimensions in mm [inch]

1) Stock types

Dual function counters **Pulse + time for DIN rail (AC+DC)** **SHC 77**



The counter combinations SHC 77 comprise an hour meter and a totalizer. They can be controlled both simultaneously and separately.

These DIN rail mount counters have a reduced mounting depth. They can be used in many different fields of application.

Product overview
Basics

Pulse counters

Preset counters

Hour meters
Timers

Frequency displays
Tachometers

Position displays

Multifunction
devices

Energy meters

Process devices

Temperature
devices

Strain-gauge
controllers

Accessories
Index

Characteristics

- Hour meter and totalizer in one single device optional: counters controlled separately.
- Without reset.
- High shock resistance.
- Magnified large figures.
- Protection IP52 (on the front side).
- Data retention in case of power failure.

- Long service life.
- UL-approved.

Applications

General counting, alarm systems, pay stations, electricity meters, vending and gaming machines, copying machines, medical equipment, car washes, lifts, heating burners.

Type series

Description	Type	Options
Dual function counter, common connections	SHC 77	SHC 77: The two meters are connected in parallel, this means, that the adding counter registers the total number of events and the time meter the total operating time of the device.
Dual function counter, separate connections	SHC 77.60	SHC 77.60: Hour meter and adding counter have two separate connections. This version is available for either AC or DC version (not mixed).
Order information: Art. no. (for special voltages etc. indicate exact counter types, voltage and frequency e.g. SHC 77, 120 V AC, 60 Hz)		

General technical data

Operating indicator of the hour meter	AC	fast rotating wheels with red dashes: 99999.99 h
	DC	1/100 h display turns continuously by 1 digit per 36 s: 999999.99 h
Height of figures	4 x 1.7 mm [0.16 x 0.067"] optical	
Color of figures	hour meter	hours: white figures on black
	1/10 u. 1/100 h adding counter	red figures on black white figures on black
Operating temperature	-15°C ... +50°C [+5°F ... +122°F] (non-condensing)	
Mounting position	any	

Mechanical characteristics

Protection	IP52 (front side) when built-in	
Color of housing	black (standard)	
Weight	SHC 77	85 g [3.00 oz]
	SHC 77.60	105 g [1.70 oz]

Electrical characteristics

Electrical connection	SHC 77	screw terminal (tightening torque max. 0.8 Nm)
	SHC 77.60	2 x cable – 2 x 0.5 mm ² [AWG20] NYFAZ, 0.5 m [1.64'] hour meter red/black adding counter grey
Power consumption	10 ... 30 V DC	approx. 1 W
	36 ... 80 V DC	approx. 1.65 W
	100 ... 130 V DC	approx. 1.75 W
	20 ... 30 V AC, 50 Hz	approx. 0.53 VA
	42 ... 48 V AC, 50 Hz	approx. 0.53 VA
	100 ... 130 V AC, 50 Hz 187 ... 264 V AC, 50 Hz	approx. 1.43 VA approx. 3.0 VA
Rated voltages	AC (50 or 60 Hz)	20 ... 30/42 ... 48/100 ... 130/187 ... 264 V DC 10 ... 30/36 ... 80/100 ... 130 V
On time	100 %	
Count mode	adding	
Accuracy	AC	supply frequency + 30 ms
	DC	< 0.003 % (at 24 h)
Reset	no reset	
Test voltage	2500 V AC, 50 Hz	
EMC standards	EN 55011 class B EN 61000-6-2, EN 61000-6-3	
Device safety	designed to protection class	EN 61010 part 1
	application area	2 pollution level 2
UL approval	file E128604	

Hour meters / timers, electromechanical

Dual function counters

Pulse + time for DIN rail (AC+DC)

SHC 77

Dual function counter
with common connections

Type SHC 77

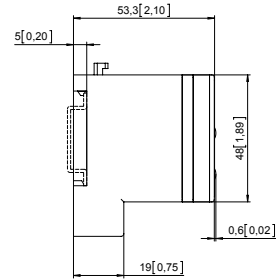
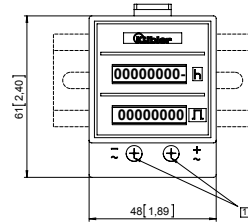

1 screw terminal

Type	Display	Voltage	Art. no.					
			10 ... 30 V	20 ... 30 V	36 ... 80 V	42 ... 48 V	100 ... 130 V	187 ... 264 V
SHC 77	7/8 digits	AC (50 Hz)		3.553.401.071		3.553.401.072	3.553.401.074	3.553.401.075
	7/8 digits	AC (60 Hz)		3.553.401.081		3.553.401.082	3.553.401.084	3.553.401.085
	7/8 digits	DC	3.553.401.351		3.553.401.353		3.553.401.381	

Dual function counter
with separate connections

Type SHC 77.60

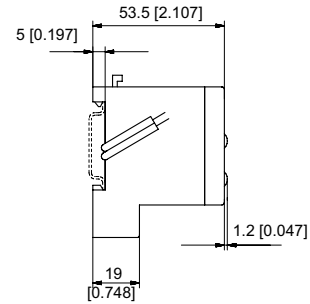
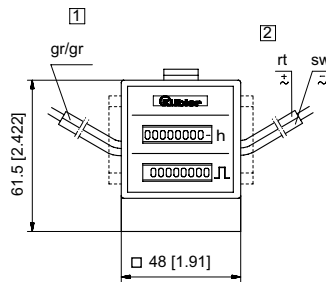

1 adding counter

2 hour meter

Type	Display	Voltage	Art. no.					
			10 ... 30 V	20 ... 30 V	36 ... 80 V	42 ... 48 V	100 ... 130 V	187 ... 264 V
SHC 77.60	7/8 digits	AC (50 Hz)		3.553.401.071.060		3.553.401.072.060	3.553.401.074.060	3.553.401.075.060
	7/8 digits	AC (60 Hz)		3.553.401.081.060		3.553.401.082.060	3.553.401.084.060	3.553.401.085.060
	7/8 digits	DC	3.553.401.351.060		on request		3.553.401.381.060	

Time preset counters, electromechanical

Standard time preset counters	Adding with mechanical reset (AC+DC)	HVa 15
-------------------------------	--------------------------------------	--------



The time preset counters HVa 15 (with manual reset) have a robust construction.

They are used in harsh industrial environments as single counters or in combination, as a plug-in version, with other B, BVa, HB or HVa counters. They display the current counter value and the preset value.

Product overview
Basics

Pulse counters

Preset counters

Hour meters
Timers

Frequency displays
Tachometers

Position displays

Multifunction
devices

Energy meters

Process devices

Temperature
devices

Strain-gauge
controllers

Accessories
Index

Characteristics	<ul style="list-style-type: none"> 5-digit adding time preset counter with stationary preset. Manual reset. Potential-free changeover contact (microswitch) when the preset time is reached. Contact remains switched until reset occurs. Counter without front bezel, for mounting in front bezel F2B; can be combined in 50 x 50 mm size. 	Benefits	<ul style="list-style-type: none"> Can be combined with the counters of the B, BVa, HB and HVa series. Counter value and preset value are constantly displayed. Versions with transparent cover, sealing cover, lockable zero reset.
Applications	Time control, automation.		

Type series			
Description	Type	Options	
Mounting clip	HVa 15.21	· Lockable 0-reset	
Front bezel 3, with mounting holes	HVa 15.31	<ul style="list-style-type: none"> Housing: black (standard) Art. no. 3.30X.X17.XXX grey Art. no. 3.30X.X16.XXX HVa 15.01 (without front bezel) <ul style="list-style-type: none"> - plugs into socket box 946.1 - DIN Rail mount SR 3 Housing black (standard) Art. no. 3.300.011.XXX grey Art. no. 3.300.010.XXX 	

Accessories	Dimensions in mm [inch]	Order no.
Socket box, type 946.1	for HVa 15 for plug-in connections in front bezel F2B	black G008439
Sealing cover type K2, IP65	suitable for front bezel 75 x 60 [2.95 x 2.36] with screw mounting	grey G008302
		black G008303
Mounting frame with cut-out 50 x 50 [1.97 x 1.97] via separate adapter also for 45 x 45 [1.77 x 1.77]	for snap-on mounting on 35 [1.38] top-hat DIN rail, for counters 48 x 48 [1.89 x 1.89], 53 x 28 [2.09 x 2.09] and 55 x 55 [2.17 x 2.17]	chromated G300003
DIN rail mount SR 3	for snap-on mounting on 35 [1.38] top-hat DIN rail	G300002

Suitable gaskets, other accessories and installation examples for optional accessories can be found in chapter accessories or in the accessories section under: www.kuebler.com/accessories.

Time preset counters, electromechanical

Standard time preset counters Adding with mechanical reset (AC+DC) HVa 15

Technical data

General technical data		
Color of figures	hours	figures white on black
	1/10 and 1/100 h	figures red on white
preset	hours	figures yellow on black
	1/10 and 1/100 h	figures red on white (approx. 4 mm [0.16"] high)
Reset	manual	
Mounting position	any	
Operating temperature	-15°C ... +50°C [+5°F ... +122°F] (non-condensing)	
Gasket	oil and gasoline-resistant synthetic rubber, particularly suitable for use with acids and alkalis, very good age stability	

Mechanical characteristics		
Protection	sealing cover K1	IP42 (front side)
	transparent cover Dv and Dvs	IP65 (front side)
Color of housing	black (standard)	
EMC standards	EN 55011 class B EN 61000-6-2, EN 61000-6-3	
Device safety	designed to protection class	EN 61010 part 1 2
	application area	pollution level 2

Electrical characteristics		
Switching contact	1 changeover contact (micro switch) release at the preset time	
	loading capacity at AC	max. 250 V, max. 2 A
	loading capacity at DC (ohmic load)	24 V max. 2.0 A 60 V max. 0.7 A 115 V max. 0.4 A 230 V max. 0.2 A
	With inductive load, spark quenching is required reducing the max. current to 60 %	
Test voltage	2000 V AC, 50 Hz for AC counter	
Electrical connection	tinned round pins \varnothing 1.6 mm [0.063"], with push on connectors	
Power consumption	10 ... 30 V DC	approx. 0.5 W
	36 ... 80 V DC	approx. 0.9 W
	100 ... 130 V DC	approx. 0.75 W
	20 ... 30 V AC, 50 Hz	approx. 0.3 VA
	42 ... 48 V AC, 50 Hz	approx. 0.25 VA
	100 ... 130 V AC, 50 Hz	approx. 0.6 VA
	187 ... 264 V AC, 50 Hz	approx. 1.2 VA
360 ... 440 V AC, 50 Hz	approx. 1.65 VA	
Rated voltages	AC (50 or 60 Hz)	20 ... 30/42 ... 48/100 ... 130/187 ... 264, 360 ... 440 V
	DC	10 ... 30/36 ... 80/100 ... 130
On time	100 %	
Count mode	adding	
Count range	AC	999.99 h
	DC	9999.9 h

Terminal assignment

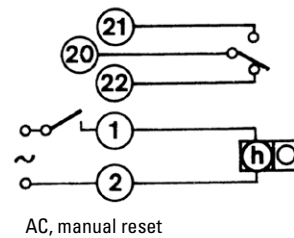
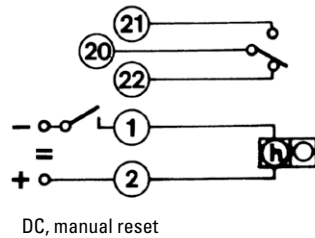

Mounting clip Type HVa 15.21

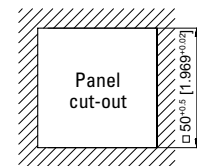
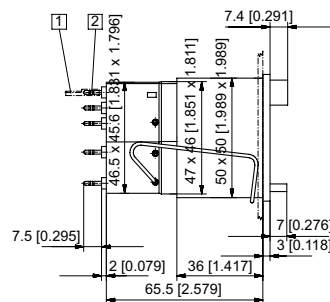
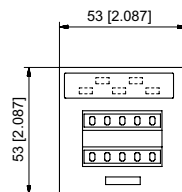

1 Push on connector \varnothing 1.5 [0.059] tinned 2 Round pin \varnothing 1.6 [0.063] tinned

Type	Voltage	Art. no.					
		10 ... 30 V	20 ... 30 V	42 ... 48 V	100 ... 130 V	187 ... 264 V	360 ... 440 V
HVa 15.21	AC (50 Hz)		3.300.211.071	3.300.211.072	3.300.211.074	3.300.211.075	on request
	AC (60 Hz)		3.300.211.081	3.300.211.082	3.300.211.084	3.300.211.085	on request
	DC	3.300.211.351					

Time preset counters, electromechanical

Standard time preset counters **Adding with mechanical reset (AC+DC)** **HVa 15**

Front bezel 3, with mounting holes
Type HVa 15.31

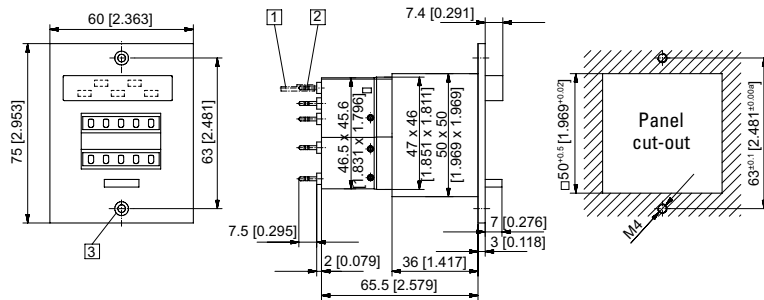

1 Push on connector \varnothing 1.5 [0.059] tinned 2 Round pin \varnothing 1.6 [0.063] tinned 3 Countersinking Af4, DIN 74

Type	Voltage	Art. no.					
		10 ... 30 V	20 ... 30 V	42 ... 48 V	100 ... 130 V	187 ... 264 V	360 ... 440 V
HVa 15.31	AC (50 Hz)		3.300.311.071	3.300.311.072	3.300.311.074	3.300.311.075	on request
	AC (60 Hz)		3.300.311.081	3.300.311.082	3.300.311.084	3.300.311.085	on request
	DC	3.300.311.351					

Mounting examples for optional accessories

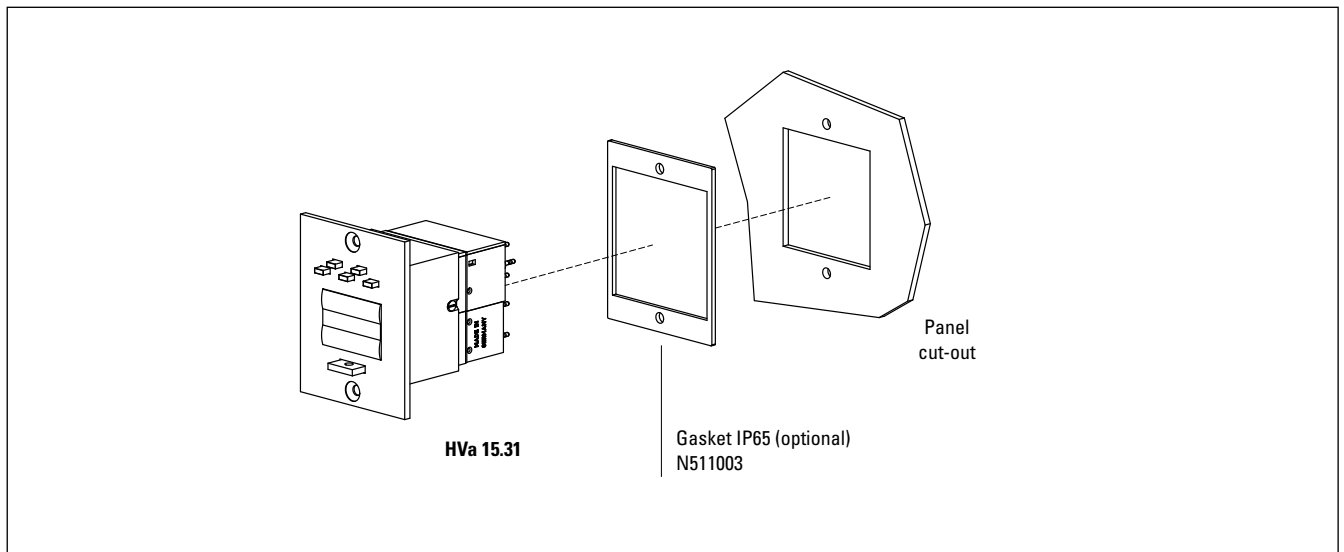

Dimensions in mm [inch]

Product overview
Basics
Pulse counters
Preset counters
Hour meters
Timers
Frequency displays
Tachometers
Position displays
Multifunction devices
Energy meters
Process devices
Temperature devices
Strain-gauge controllers
Accessories
Index

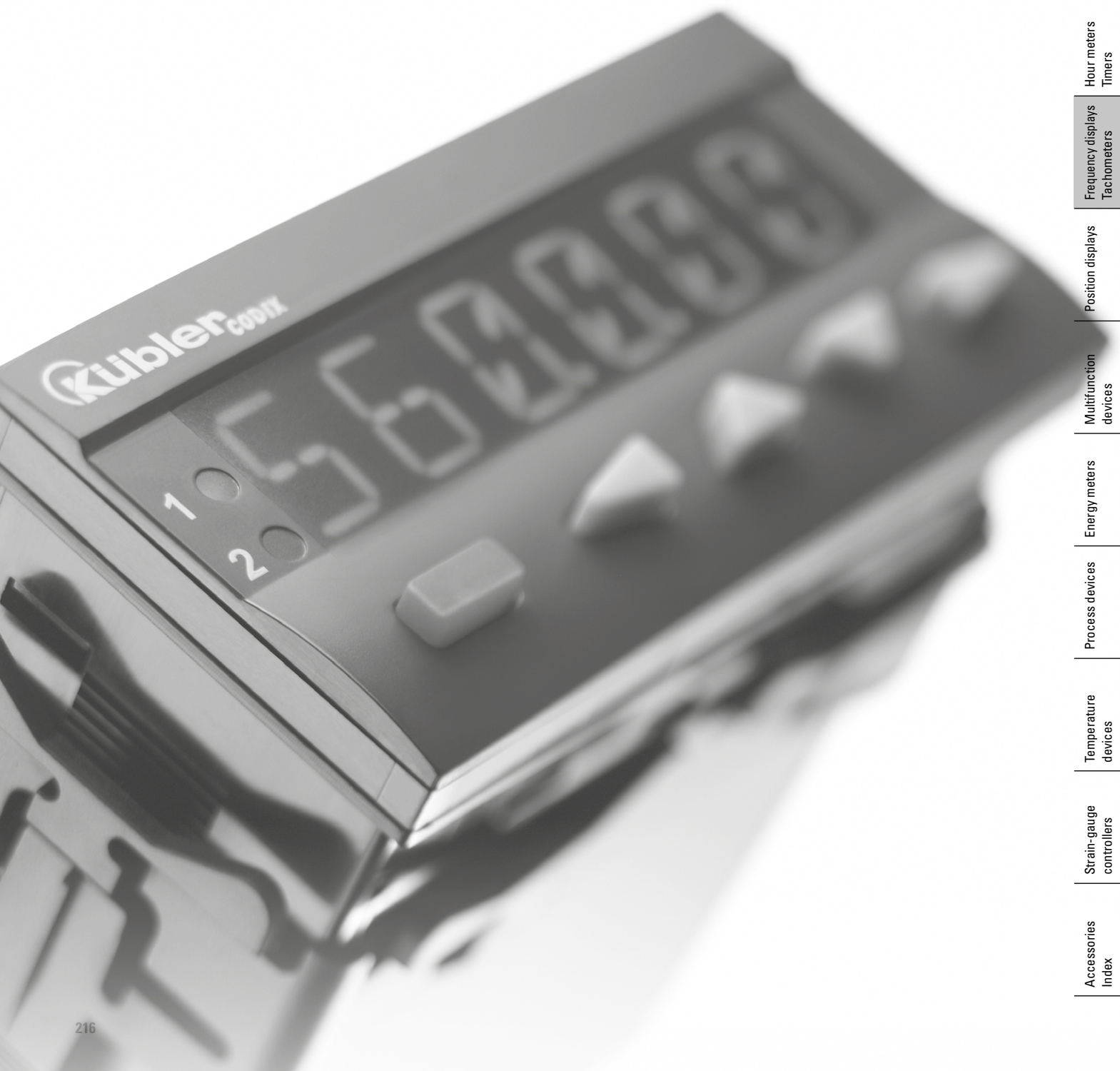

Product overview
Basics

Pulse counters

Preset counters

Hour meters
Timers

Frequency displays
Tachometers

Position displays

Multifunction
devices

Energy meters

Process devices

Temperature
devices

Strain-gauge
controllers

Accessories
Index

Frequency displays / tachometers

Frequency displays / tachometers		Type	Page
LCD frequency display	Measuring in Hz (battery)	Codix 136	218
LED frequency displays	Measuring range 1/min or 1/sec HRA-measurement (DC)	Codix 522	221
	Multifunctional – pulse, frequency, time (DC)	Codix 524	240
	Universal with dual functions 4 combinations (DC)	Codix 52U	250
	6 count modes with tachometer (DC)	Codix 52P	254
	Measuring range 1/min or 1/sec HRA-measurement (AC+DC)	Codix 542	224
	Multifunctional – pulse, frequency, time (AC+DC)	Codix 544	244
	Universal with dual functions 4 combinations (AC+DC)	Codix 54U	258
	6 count modes with tachometer (AC+DC)	Codix 54P	261
Frequency displays / tachometers with limits		Type	Page
LCD tachometer	Multifunctional – pulse, frequency, time – 1 ... 6 presets (AC+DC)	Codix 923 / 924	127
Tachometer with multicolor, LED look	Multifunctional – pulse, frequency, time – 1 ... 6 presets (AC+DC)	Codix 923 / 924	127
LED tachometers	Multifunctional – pulse, frequency, time – 65 kHz, 2 presets (AC+DC)	Codix 560	134
	Pulse, frequency, time (also reciprocal), with analog output (AC+DC)	574	227
LCD touch tachometer	 Pulse, frequency, time (also reciprocal) – (AC+DC)	571T	247

Product overview
Basics
Pulse counters
Preset counters
Hour meters
Timers
Frequency displays
Tachometers
Position displays
Multifunction devices
Energy meters
Process devices
Temperature devices
Strain-gauge controllers
Accessories
Index

Frequency displays / tachometers

LCD frequency displays	Measuring range in Hz (battery)	Codix 136
-------------------------------	--	------------------



The Codix 136 is a simple battery powered frequency display / tachometer for NPN, PNP pulses.
Fast and slow count pulses are displayed directly in Hz via the 8-digit LCD display with its optional backlighting.



Battery powered	Frequency display/Tachometer	PNP/NPN	Pulse voltage 4 ... 30 V	Max. count frequency 12 kHz	Temperature range -10°... +60°C	High protection level IP65	DIN front bezel DIN 48 x 24	LCD display 8 LCDs	Lockable reset

Powerful

- Input frequency range from 1 Hz ... 12 kHz – gate measuring method, gate time 1 second.
- Battery life approx. 8 years.
- Filter function for bounce-free counting with mechanical contacts .
- Count frequency max. 12 kHz – accuracy 0.05 %.
- High protection level IP65.

Simple

- Screw terminals, RM 5 mm.
- For positive or negative edges, depending on version.
- Large 8-digit LCD display with 8 mm high figures and optional backlighting.
- Display directly in Hz.

Order code 6.136 . 012 . 8XX

a Backlighting
5 = without¹⁾
6 = with

b Count input

Mode	INP A			INP B		
0 = Tacho	0 ... 0.7 V DC	NPN	7 kHz	0 ... 0.7 V DC	NPN	30 Hz
1 ¹⁾ = Tacho	4 ... 30 V DC	PNP	12 kHz	0 ... 0.7 V DC	PNP	30 Hz

Delivery specification

- Pulse counter
- Mounting clip
- Front bezel for screw mounting (T008181) 56 x 40 mm [2.20 x 1.57"], panel cut-out 50 x 25 mm [1.97 x 0.98"]
- Front bezel for clip mounting (T008180) 53 x 28 mm [2.09 x 1.10"], panel cut-out 50 x 25 mm [1.97 x 0.98"]
- Gasket
- Instruction manual, multilingual

1) Stock types

Frequency displays / tachometers

LCD frequency displays	Measuring range in Hz (battery)	Codix 136
Accessories	Dimensions in mm [inch]	Order no.
Adapter front bezel, 72 x 36 [2.83 x 1.42]	For cut-out 68 x 33 [2.68 x 1.30] to cut-out 45 x 22.2 [1.77 x 0.87], for counters 48 x 24 [1.89 x 0.94], as set black and silver anodised	162704 Set
Adapter front bezel, 48 x 48 [1.89 x 1.89]	For cut-out 45 x 45 [1.77 x 1.77] to cut-out 45 x 22.2 [1.77 x 0.87], with clip mounting for counters 48 x 24 [1.89 x 0.94] black	T008883
Adapter front bezel, 60 x 50 [2.36 x 1.97]	For cut-out 54 x 29 [2.13 x 1.14] to cut-out 45 x 22.2 [1.77 x 0.87], with screw mounting and gasket for counters 48 x 24 [1.89 x 0.94] black	N003001
Transparent cover, lockable, IP65	For cut-out 54 x 29 [2.13 x 1.14], for screw mounting to front bezel F1B or adapter front bezel N003001, for counters with cut-out 50 x 25 [1.97 x 0.98] or 45 x 22.2 [1.77 x 0.87]	N003002
Sealing cover type K1, IP65	Suitable for front bezel 60 x 50 [2.36 x 1.97], for screw mounting of electromech. counters and via adapter front bezel N003001 for counters 48 x 24 [1.89 x 0.94]	G008301
Mounting frame with cut-out 50 x 25 [2.36 x 1.97] via separate adapter also for 45 x 22.2 [1.77 x 0.87]	For snap-on mounting on 35 [1.38] top-hat DIN rail, for counters 53 x 28 [2.09 x 1.10] and via separate adapter (T008180) for counters 48 x 24 [1.89 x 0.94] chromated	G300004

Suitable gaskets, other accessories and installation examples for optional accessories can be found in chapter accessories or in the accessories section under: www.kuebler.com/accessories.

Technical data

General technical data	
Display	LCD, 8 digits, 8 mm [0.32"] high
Backlighting	external electrical source 24 V DC $\pm 20\%$, 50 mA
Display range	0 ... 99999999
Resolution	1/sec (1 Hz)
Working temperature	-10°C ... +55°C [+14°F ... +131°F] (non-condensing)
Operating temperature	-10°C ... +60°C [+14°F ... +140°F] (non-condensing)
Storage temperature	-20°C ... +70°C [-4°F ... +158°F]

Electrical characteristics	
Power supply	internal lithium battery approx. 8 years at 20°C [68°F]
EMC standards	EN 55011 class B, EN 61000-6-2, EN 61000-6-3
Device safety	designed to protection class 2 application area pollution level 2 EN 61010 part 1
UL approval	file E128604

Mechanical characteristics	
Housing	dark grey RAL 7021
Protection	IP65 (front side)
Weight	approx. 50 g [1.76 oz]

Counting inputs		
Counting input of the DC-versions (max. 30 V DC)		
slow counting input	max.	30 Hz NPN or PNP
fast counting input	max.	12 kHz (PNP), 7 kHz (NPN)
switching level NPN	LOW	0 ... 0.7 V DC
	HIGH	3 ... 30 V DC
switching level PNP	LOW	0 ... 0.7 V DC
	HIGH	4 ... 30 V DC

Frequency displays / tachometers

LCD frequency displays Measuring range in Hz (battery) Codix 136

Terminal assignment

DC type: 6.136.012.8x0

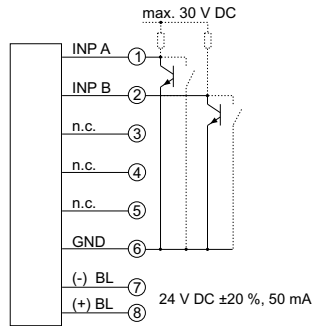

BL = backlighting

DC type: 6.136.012.8x1

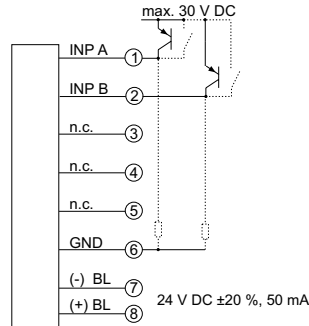

BL = backlighting

Dimensions

Dimensions in mm [inch]

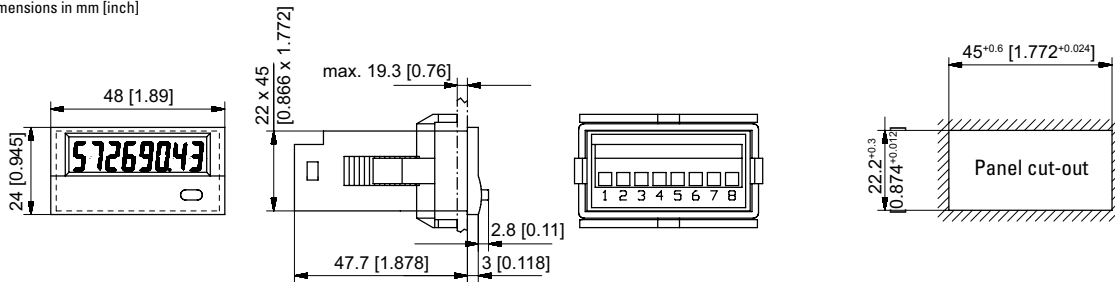

Front bezel for clip mounting (included in delivery)

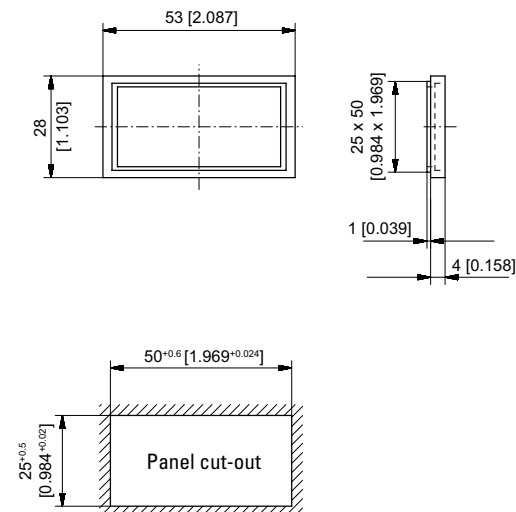

Front bezel for screw mounting (included in delivery)

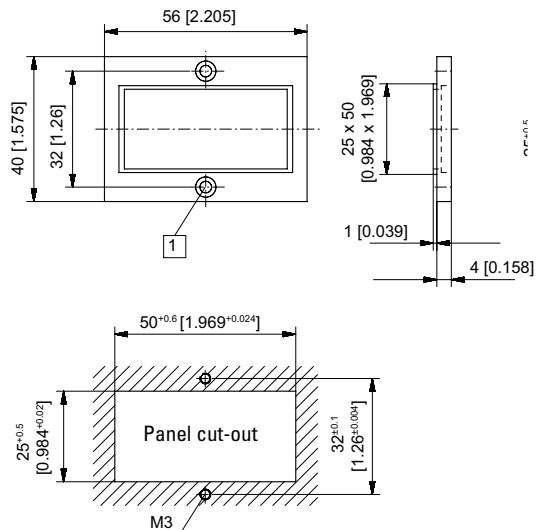

1 Countersinking Af3, DIN 74

LED frequency displays

Measuring range 1/min or 1/sec HRA-measurement (DC)

Codix 522



The Codix 522 is a simple voltage powered frequency display / tachometer.

Display in 1/min or 1/sec, freely scalable, for fast and slow count pulses, with 6-digit LED display for NPN, PNP input signals, with fast HRA measurement system (High Rate Accuracy).



DC 10 ... 30 V Power supply	000000 DIN 48 x 24 DIN front bezel	-20...+65°C Temperature range	IP65 High protection level	Prog Menu-driven programming	1/sec 1/min Frequency display/ Tachometer	t / Hz HRA Frequency display with HRA
--	---	---	--------------------------------------	--	---	--

Powerful

- Very bright LED display, 8 mm high.
- Fast count input – input frequency max. 60 kHz.
- Robust housing – IP65 protected.
- Very accurate precise frequency measurement principle (HRA - High Rate Accuracy System)
Frequencies up to 38 Hz are calculated using time-interval (period duration) measurement. Frequencies > 38 Hz are calculated using a special time base (gate time) measurement. A very high accuracy of < 0.1 % is achieved, even with very short gate times. The resulting measurement is available after a max. of 50 ms.

User-friendly and universal

- Large keys – can also be operated when wearing gloves.
- Simple uniform menu-driven programming and operation. Possible to enter the programming also during operation with a confirmation prompt.
- Individually programmable scaling – multiplication and division factor (0.0001 to 99.9999), to display corresponding engineering units, e.g. frequency in Hz and speed in RPM.
- Programmable decimal point, can be set from 0.0 to 0.000 (this determines the resolution).
- Programmable delay until 0 is displayed.
- Display in 1/min or 1/sec.
- As an alternative to the HTL inputs, devices with a 4 ... 30 V DC input level are available.
- Optional output for zero-speed monitoring.

Order code

6.522 . 01 X . 3 X 0

a Output

- 1 = optocoupler output
- 2 = no output ¹⁾

b Input switching level

- 0 = Standard (HTL) ¹⁾
- A = 4 ... 30 V DC level

Delivery specification

- Pulse counter
- Mounting clip
- Front bezel for screw mounting (T008181) 56 x 40 mm [2.20 x 1.57"], panel cut-out 50 x 25 mm [1.97 x 0.98"]
- Front bezel for clip mounting (T008180) 53 x 28 mm [2.09 x 1.10"], panel cut-out 50 x 25 mm [1.97 x 0.98"]
- Gasket
- Instruction manual, multilingual

1) Stock types

Frequency displays / tachometers

LED frequency displays Measuring range 1/min or 1/sec HRA-measurement (DC) Codix 522

Accessories	Dimensions in mm [inch]	Order no.
Adapter front bezel, 72 x 36 [2.83 x 1.42]	for cut-out 68 x 33 [2.68 x 1.30] to cut-out 45 x 22.2 [1.77 x 0.87], for counters 48 x 24 [1.89 x 0.94], as set black and silver anodised	162704 Set
Adapter front bezel, 48 x 48 [1.89 x 1.89]	for cut-out 45 x 45 [1.77 x 1.77] to cut-out 45 x 22.2 [1.77 x 0.87], with clip mounting for counters 48 x 24 [1.89 x 0.94] black	T008883
Adapter front bezel, 60 x 50 [2.36 x 1.97]	for cut-out 54 x 29 [2.13 x 1.14] to cut-out 45 x 22.2 [1.77 x 0.87], with screw mounting and gasket for counters 48 x 24 [1.89 x 0.94] black	N003001
Transparent cover, lockable, IP65	for cut-out 54 x 29 [2.13 x 1.14], for screw mounting to front bezel F1B or adapter front bezel N003001, for counters with cut-out 50 x 25 [1.97 x 0.98] or 45 x 22.2 [1.77 x 0.87]	N003002
Sealing cover type K1, IP65	suitable for front bezel 60 x 50 [2.36 x 1.97], for screw mounting of electromech. counters and via adapter front bezel N003001 for counters 48 x 24 [1.89 x 0.94]	G008301
Mounting frame with cut-out 50 x 25 [2.36 x 1.97] via separate adapter also for 45 x 22.2 [1.77 x 0.87]	for snap-on mounting on 35 [1.38] top-hat DIN rail, for counters 53 x 28 [2.09 x 1.10] and via separate adapter (T008180) for counters 48 x 24 [1.89 x 0.94] chromated	G300004

Suitable gaskets, other accessories and installation examples for optional accessories can be found in chapter accessories or in the accessories section under: www.kuebler.com/accessories.

Technical data

General technical data	
Display	6 digits, red 7 segment LED display; 8 mm [0.32"] high
Data backup	EEPROM
Operating temperature	10 ... 26 V DC -20°C ... +65°C [-4°F ... +149°F] > 26 ... 30 V DC -20°C ... +55°C [-4°F ... +131°F] (non-condensing)
Storage temperature	-25°C ... +70°C [-13°F ... +158°F]
Mechanical characteristics	
Housing	front panel mount 8 x 24 mm [1.89 x 0.94"] acc. to DIN 43700; RAL 7021, dark grey
Protection	IP65 (front side)
Weight	approx. 50 g [1.76 oz]
Vibration resistance acc. to EN 60068-2-6	10 ... 55 Hz / 1 mm [0.04"] / 30 min
Shock resistance acc. to EN 60068-2-27	100 G: 2 ms 10 G: 6 ms
Outputs (optional)	
Optocoupler output	max. 30 V DC, 10 mA

Electrical characteristics	
Power supply	10 ... 30 V DC, with integrated reverse polarity protection
Current consumption	max. 50 mA
EMC standards	EN 55011 class B, EN 61000-6-2, EN 61000-6-3 EN 61326-1
UL approval	file E128604
Inputs	
Polarity of inputs	programmable, NPN or PNP
Input resistance	approx. 5 kΩ
Counting frequency	max. 60 kHz, can be damped to 30 Hz
Measurement principle / Accuracy	Gate and/or time interval (period duration) measurement, with high accuracy <0.1 % (HRA)
Input switching level (HTL)	LOW 0 ... 0.2 x U _B [V DC] HIGH 0.6 x U _B ... 30 V DC
Input switching level at 4 ... 30 V DC	LOW 0 ... 2 V DC HIGH 4 ... 30 V DC

Applications for speed and frequency displays

- Rotary speed applications, e.g. OEM equipment or retrofitting to drilling machines
- OEM equipment for flow rate measuring, e.g. current flow rate; production data such as volume/time
- Speed applications on motors, turbines, machines; feed-rate measurement
- Recording of production rates
- Frequency measurement

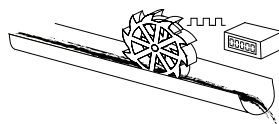

Mass flow rate

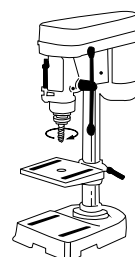

Drilling machine head, rotary speed

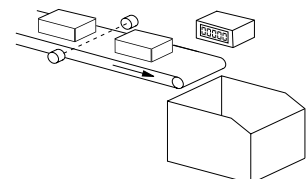

Production rate

Frequency displays / tachometers

LED frequency displays Measuring range 1/min or 1/sec HRA-measurement (DC) Codix 522

Block diagram

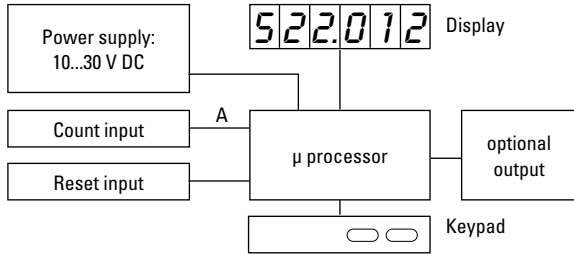

Terminal assignment

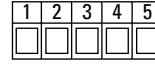

PIN	without optocoupler
1	10 ... 30 V DC
2	0 V GND
3	INP
4	-
5	-

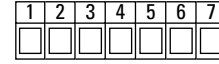

PIN	with optocoupler (NPN)
1	10 ... 30 V DC
2	0 V GND
3	INP
4	-
5	-
6	Emitter
7	Collector

Dimensions

Dimensions in mm [inch]

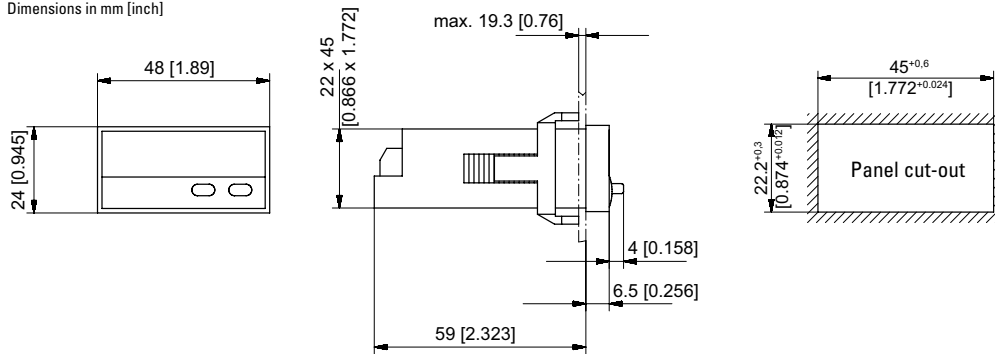

Front bezel for clip mounting (included in delivery)

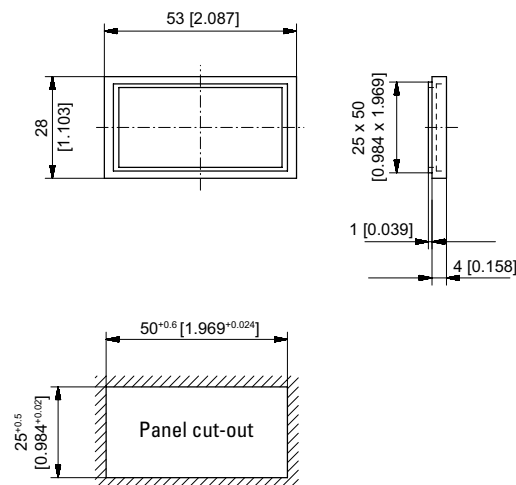

Front bezel for screw mounting (included in delivery)

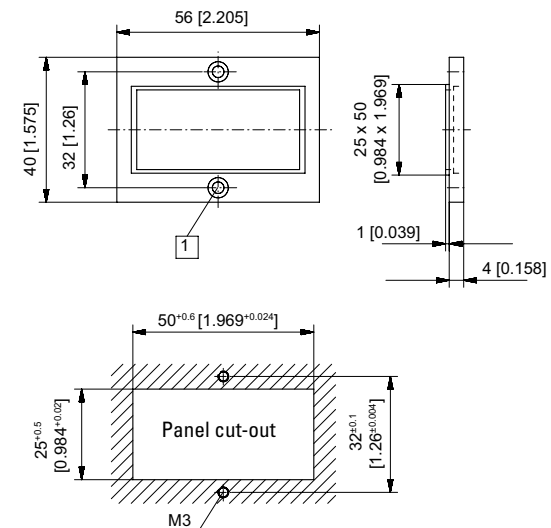

1 Countersinking Af3, DIN 74

Frequency displays / tachometers

LED frequency displays **Measuring range 1/min or 1/sec HRA-measurement (AC+DC)** **Codix 542**



The Codix 542 is a voltage powered frequency display / tachometer, with 6-digit LED display for NPN, PNP input signals. The display in 1/min or 1/sec is freely scalable for fast and slow count pulses – with fast HRA measurement system (High Rate Accuracy).



DC 10 ... 30 V Power supply	AC 100 ... 240 V Power supply	-20°...+65°C Temperature range	IP65 High protection level	Plug-in screw terminal	Menu-driven programming	Operation with gloves	1/sec 1/min Frequency display/ Tachometer	HRA Frequency display with HRA
--	--	--	--------------------------------------	-------------------------------	--------------------------------	------------------------------	---	--

Powerful

- Very bright LED display, 14 mm high.
- Fast count input – input frequency max. 60 kHz.
- Robust housing – IP65 protected.
- Very accurate precise frequency measurement principle (HRA - High Rate Accuracy System)
Frequencies up to 38 Hz are calculated using time-interval (period duration) measurement. Frequencies > 38 Hz are calculated using a special time base (gate time) measurement. A very high accuracy of < 0.1 % is achieved, even with very short gate times. The resulting measurement is available after a max. of 50 ms.

User-friendly and universal

- Large keys – can also be operated when wearing gloves.
- Simple uniform menu-driven programming and operation. Possible to enter the programming also during operation with a confirmation prompt.
- Programmable decimal point, can be set from 0.0 to 0.000 (this determines the resolution).
- As an alternative to the HTL inputs, devices with a 4 ... 30 V DC input level are available.
- Individually programmable scaling – multiplication and division factor (0.0001 to 99.9999), to display corresponding engineering units, e.g. frequency in Hz and speed in RPM.
- Programmable delay until 0 is displayed.
- Display in 1/min or 1/sec.
- AC or DC power supply with sensor power supply.
- Optional output for zero-speed monitoring.

Order code

6.542 . 01 X . X X 0

a Output

- 1 = Optocoupler output
- 2 = No output ¹⁾

b Power supply

- 0 = 100 ... 240 V AC, ±10 % ¹⁾
- 3 = 10 ... 30 V DC ¹⁾

c Input switching level

- 0 = Standard level (HTL) ¹⁾
- A = 4 ... 30 V DC level

Delivery specification

- Digital display
- Mounting clip
- Gasket
- Instruction manual, multilingual

1) Stock types

Frequency displays / tachometers

LED frequency displays Measuring range 1/min or 1/sec HRA-measurement (AC+DC) Codix 542

Accessories	Dimensions in mm [inch]	Order no.
Mounting frame with cut-out 92 x 45 [3.62 x 1.77]	for snap-on mounting on 35 [1.38] top-hat DIN rail, for counters 96 x 48 [3.74 x 1.89]	grey G300005

Suitable gaskets as well as further accessories can be found in the accessories section or in the accessories area of our website at: www.kuebler.com/accessories.

Technical data

General technical data	
Display	6 digit, red 7 segment LED display; 14 mm [0.55"] high
Data backup	EEPROM
Operating temperature	-20°C ... +65°C [-4°F ... +149°F] (non-condensing)
Storage temperature	-20°C ... +70°C [-4°F ... +158°F]
Altitude	up to 2000 m [6562']

Electrical characteristics	
Power supply	10 ... 30 VDC, with reverse polarity protection 100 ... 240 V AC, ±10 %
Current consumption	max. 50 mA, 6 VA
EMC standards	EN 55011 class B, EN 61000-6-2, EN 61000-6-3
Device safety	designed to protection class 2 application area pollution level 2
UL approval	file E128604

Mechanical characteristics	
Housing	front panel mount 96 x 48 mm [3.74 x 1.89"] acc. to DIN 43700; RAL 7021, dark grey
Protection	IP65 (front side)
Weight	approx. 150 g [5.29 oz]

Inputs	
Polarity of inputs	programmable, NPN or PNP for all inputs
Input resistance	approx. 5 kΩ
Counting frequency¹⁾	max. 60 kHz, can be damped to 30 Hz
Measurement principle / Accuracy	Gate and/or time interval (period duration) measurement, with high accuracy < 0.1 % (HRA)

Input switching level standard version (HTL)	
DC power supply	LOW 0 ... 0.2 x U _B [V DC] HIGH 0.6 x U _B ... 30 V DC
AC power supply	LOW 0 ... 4 V DC HIGH 12 ... 30 V DC

Input switching level at 4 ... 30 V DC	
LOW	0 ... 2 V DC
HIGH	4 ... 30 V DC

Outputs	
Sensors power supply (AC version)	24 V DC ±15 %/100 mA
Output power optocoupler	max. 30 V DC, 10 mA

Applications for speed and frequency displays

- Rotary speed applications, e.g. OEM equipment or retrofitting to drilling machines
- OEM equipment for flow rate measuring, e.g. current flow rate; production data such as volume/time
- Speed applications on motors, turbines, machines; feed-rate measurement
- Recording of production rates
- Frequency measurement

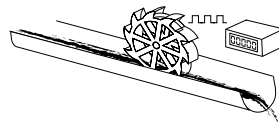

Mass flow rate

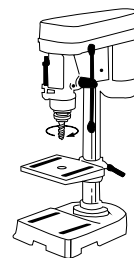

Drilling machine head, rotary speed

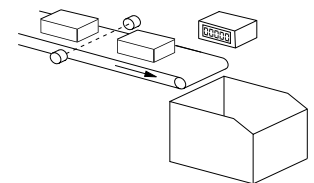

Production rate

1) Please refer to the manual

Frequency displays / tachometers

LED frequency displays

Measuring range 1/min or 1/sec HRA-measurement (AC+DC)

Codix 542

Block diagram

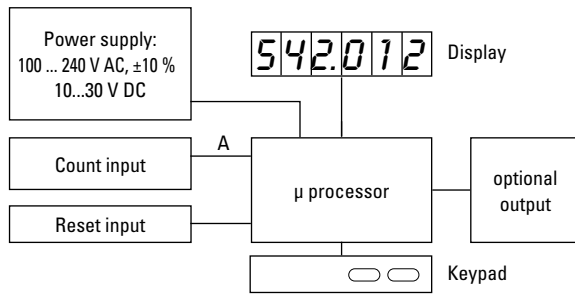

Terminal assignment

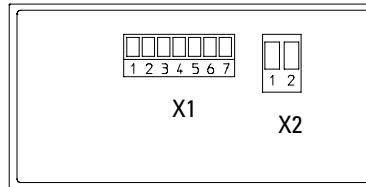

Connection X1

PIN	AC version	DC version
1	Optocoupler-output	Collector
2	Optocoupler-output	Emitter
3	n.c.	
4	n.c.	
5	INP A	
6	GND out	n.c.
7	+24 V out	n.c.

Connection X2

PIN	AC version	DC version
1	100 ... 240 V AC, ±10 %	0V DC (GND)
2	100 ... 240 V AC, ±10 %	10...30 V DC

Dimensions

Dimensions in mm [inch]

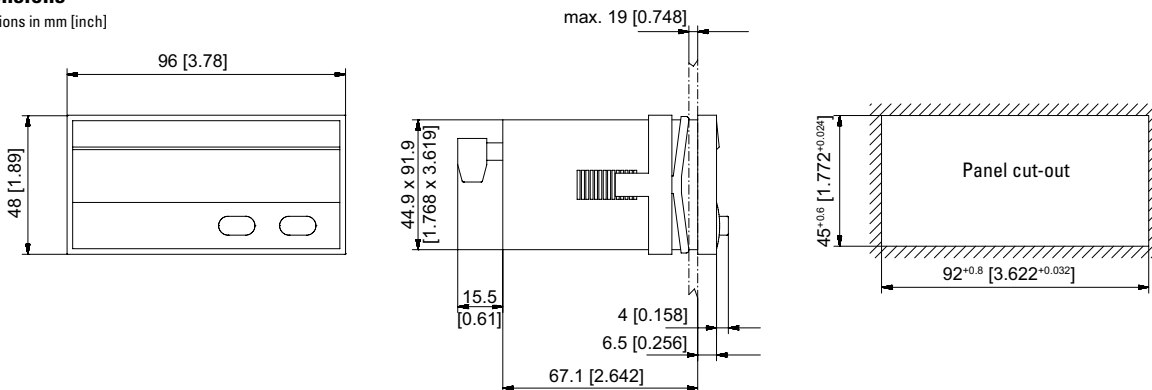

Product overview
Basics

Pulse counters

Preset counters

Hour meters
Timers

Frequency displays
Tachometers

Position displays

Multifunction
devices

Energy meters

Process devices

Temperature
devices

Strain-gauge
controllers

Accessories
Index

Frequency displays / tachometers with limits

LED tachometers	Dual frequency displays with 4 outputs and analog output (AC+DC)	574
------------------------	---	------------



Frequency display for demanding applications, with two individually scalable encoder inputs, in each case A, /A, B, /B for count frequencies up to 1 MHz per channel (also for single channel use).

Operating modes can be selected for tachometer or frequency display with measurements for difference, total value, product or ratio (also with reciprocal display).

Product overview
Basics
Pulse counters
Preset counters
Hour meters
Timers
Frequency displays
Tachometers
Position displays
Multifunction devices
Energy meters
Process devices
Temperature devices
Strain-gauge controllers
Accessories
Index

AC/DC 24/17...30V Power supply	000000 DIN 96 x 48 DIN front bezel	IP65 High protection level	max. 1 MHz 2 separate pulse inputs	 Operation with gloves	 TTL, HTL and RS422-input	6 LED LED display	DC OUT 5 / 24 V 2 x Sensor supply	 mA, V Analog output optional	4 Transistor output	RS232 Interface
---	---	--------------------------------------	---	---------------------------	------------------------------	-----------------------------	--	-------------------------------------	-------------------------------	---------------------------

Innovative

- 2 separate freely scalable frequency inputs: HTL or TTL (both also with inverted inputs), max. input frequency 1 MHz/channel.
- Very bright LED display, 15 mm high (6 digits).
- 4 freely programmable fast solid-state outputs, each with 350 mA output current.
- Many different output modes.
- Simple programming – with function codes, dependent on the operating mode selected.
- With 9 fixed different frequency functions, e.g.:
 - Single, difference and total value measurement of both inputs.
 - Product and ratio measurement.
 - Percentage measurement.
 - In-process time calculated from frequency (reciprocal speed).

Compact and multifunctional

- Up to 3 display values in a single device: display counter 1, display counter 2 as well as the display calculated from counter 1 and 2.
- AC and DC power supply in one device.
- Simple programming with 4 keys, all keys can be assigned dual programming functions.
- Can be used as a frequency display or tachometer with limit values.
- Monitoring function, where 2 values are monitored or calculated with respect to each other.
- 4 fast programmable inputs with various functions such as start delay, key lockout, display memory, reference input or switching between the display values.
- Scalable analog output 0/4 ... 20 mA, +/-10 V or 0 ... 10 V.
- Standard interface RS232 for parameter setting, for reading out the values to a PC or PLC, for modifications during operation.

Order specifications

4 fast switch outputs, serial interface (RS232)	Order no.	Delivery specification
6 digits	6.574.0116.D05	• Controller 574
6 digits, scalable analog output	6.574.0116.D95	• Gasket
6 digits, RS232 and RS485	6.574.0116.D07	• Fastening set
		• Instruction manual German/English

Accessories	Dimensions in mm [inch]	Order no.
-------------	-------------------------	-----------

Mounting frame for DIN rail mount	with cut-out 92 x 45 [3.62 x 1.77]	G300005
--	------------------------------------	----------------



OS6.0 software for parameter setting	can be downloaded at www.kuebler.com
---	---

Suitable gaskets as well as further accessories can be found in the accessories section or in the accessories area of our website at: www.kuebler.com/accessories.

Frequency displays / tachometers with limits

LED tachometers Dual frequency displays with 4 outputs and analog output (AC+DC) **574**

Technical data

General technical data		
Display	6-digit	LED display, 15 mm [0.59"] high
Operating temperature	0°C ... +45°C [+32°F ... +113°F] (non-condensing)	
Storage temperature	-25°C ... +70°C [-13°F ... +158°F]	

Electrical characteristics		
Power supply	24 V AC, + 10 % 24 (17 ... 30) V DC	
Current consumption DC	100 mA + current consumption encoder	
Connected load AC	15 VA	
Auxiliary power supply (for sensors)	2 x 5.2 V DC, each 150 mA 2 x 24 V DC, each 120 mA	
EMC standards	EN 55011 class B, EN 61000-6-2, EN 61000-6-3 EN 61326-3-2	
Device safety	designed to protection class application area	EN 61010 part 1 2 pollution level 2

Mechanical characteristics		
Housing material	Noryl UL94-V-0	
Screw terminal	cable cross-section	max. 1.5 mm ² [AWG 15]
Protection	IP65 from front	
Weight	approx. 250 g [8.82 oz]	

Inputs	
2 universal incremental encoder inputs	
Count frequency (per encoder)	
RS422 and TTL with inv.	1 MHz
HTL asymmetric	200 kHz
TTL asymmetric	200 kHz

Entrées de commande	
4 control inputs HTL	
Ri	3.3 kOhm
Low	< 2.5 V
High	> 10 V
min. pulse duration	50 µs

Outputs	
Switch outputs	
4 fast power transistors	5 ... 30 V DC, 350 mA
reaction time	< 1 ms ¹⁾
inductive loads require a freewheeling diode	
Serial interface	
	RS232, 2400 ... 38400 baud
	RS485 (6.574.0116.D07)
Analog outputs (6.574.0116.D95)	
0 / 4 ... 20 mA	load max. 270 Ohm
0 ... +10 V	max. 2 mA
Resolution	14 bit
precision	0.1 %
reaction time	< 1 ms

Application examples

Total flow rate

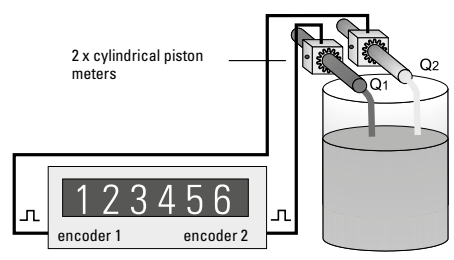

Speed difference

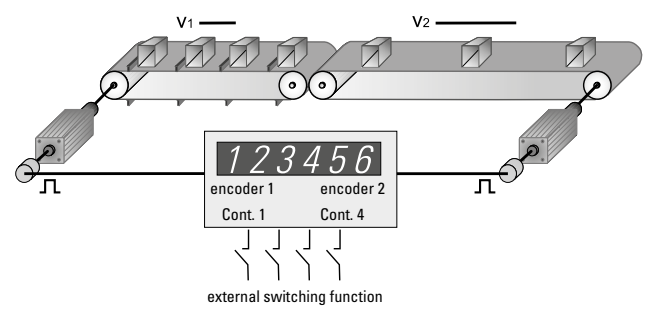

Material stretching to create tensile stress

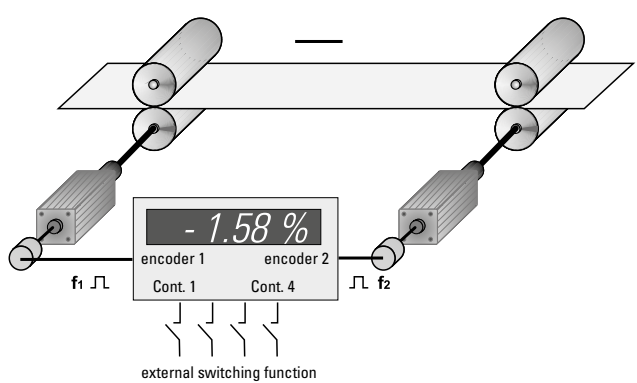

Monitoring of torsion, shafts or gear breakage

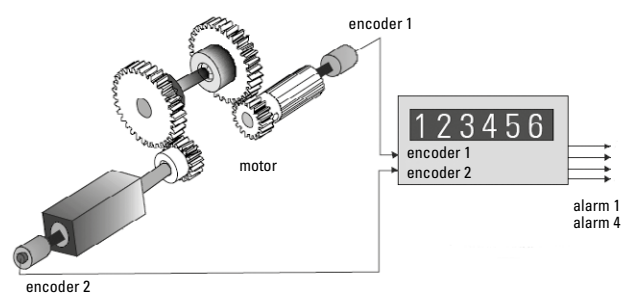

1) Intensive serial communication can temporarily increase the reaction time.

Product overview
 Basics
 Pulse counters
 Preset counters
 Hour meters
 Timers
 Frequency displays
 Tachometers
 Position displays
 Multifunction devices
 Energy meters
 Process devices
 Temperature devices
 Strain-gauge controllers
 Accessories
 Index

Frequency displays / tachometers with limits

LED tachometers	Dual frequency displays with 4 outputs and analog output (AC+DC)	574
------------------------	---	------------

Terminal assignment

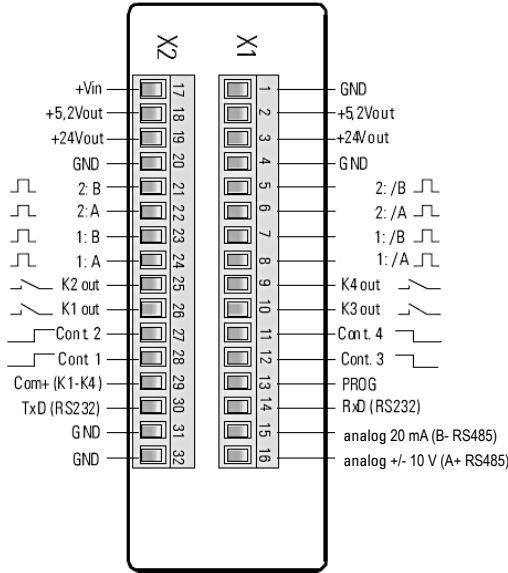

Application examples

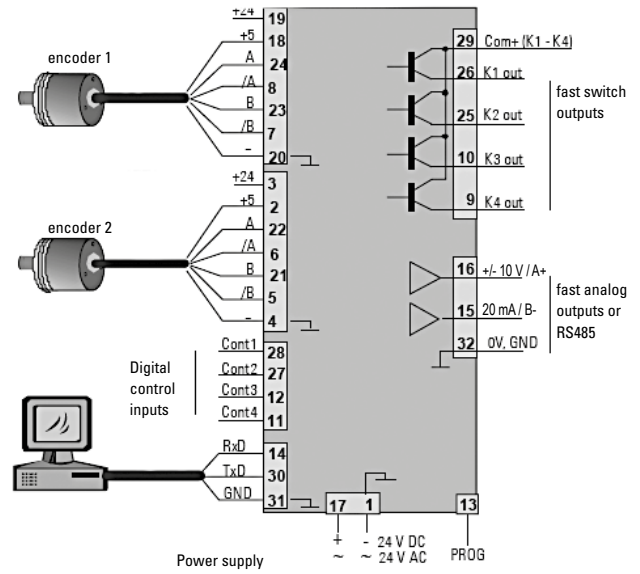

Dimensions

Dimensions in mm [inch]

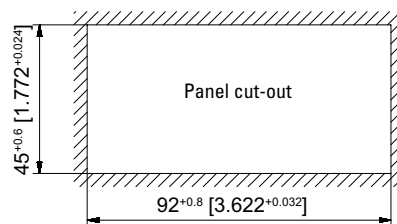
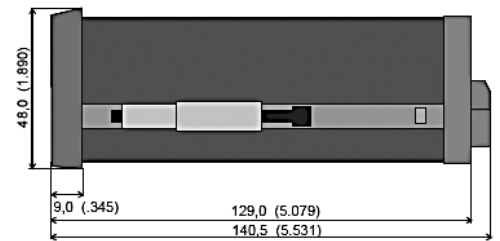
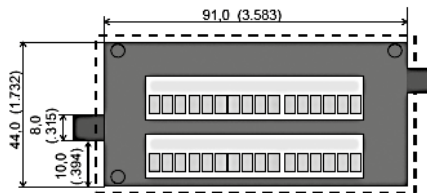
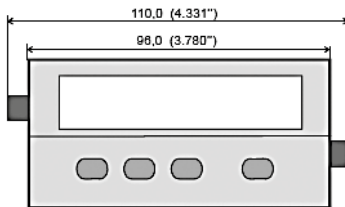

Product overview
Basics
Pulse counters
Preset counters
Hour meters
Timers
Frequency displays
Tachometers
Position displays
Multifunction devices
Energy meters
Process devices
Temperature devices
Strain-gauge controllers
Accessories
Index



Product overview
Basics

Pulse counters

Preset counters

Hour meters
Timers

Frequency displays
Tachometers

Position displays

Multifunction
devices

Energy meters



Process devices

Temperature
devices

Strain-gauge
controllers

Accessories
Index

Position displays

Position displays		Type	Page
LCD position display	Phase discriminator (quadrature) x1 and x2 evaluation (battery)	Codix 133	232
LED position displays	6 count modes (DC)	Codix 521	63
	Multifunctional – pulse, frequency, time (DC)	Codix 524	240
	6 count modes with tachometer (DC)	Codix 52P	254
	6 count modes (AC+DC)	Codix 541	75
	Multifunctional – pulse, frequency, time (AC+DC)	Codix 544	244
LED position displays	6 count modes with tachometer (AC+DC)	Codix 54P	261
LCD touch position display	 SSI absolute encoder display (AC+DC)	570T	235
Position displays with limits		Type	Page
LCD position preset counters	1 or 2 presets – pulse, time – 5 kHz (AC+DC)	Codix 907 / 908	124
	Multifunctional – pulse, frequency, time – 1 ... 6 presets (AC+DC)	Codix 923 / 924	127
Position preset counter with multicolour or LED look	Multifunctional – pulse, frequency, time – 1 ... 6 presets (AC+DC)	Codix 923 / 924	127
LCD touch position preset counters	 SSI absolute encoder display (AC+DC)	570T	235
	 Pulse, frequency, time (also reciprocal) – (AC+DC)	571T	247
LED position preset counters	Multifunctional – pulse, frequency, time – 65 kHz, 2 Vorwahlen (AC+DC)	Codix 560	134
	Dual preset counters with 4 outputs and analog output (AC+DC)	572	139
	SSI o. incremental inputs / 4 switching outputs + analog output (AC+DC)	575	142

Product overview
Basics

Pulse counters

Preset counters

Hour meters
Timers

Frequency displays
Tachometers

Position displays

Multifunction devices

Energy meters

Process devices

Temperature devices

Strain-gauge controllers

Accessories
Index

Position displays

LCD position displays Phase discriminator (quadrature) x1 and x2 evaluation Codix 133



The Codix 133 is a simple battery-powered position display with a phase discriminator (quadrature) counting input. NPN and PNP pulses can be shown on the 8-digit LCD display that is also available with optional backlighting.



Battery powered	Type of input	Phase discriminator	Pulse voltage	Max. count frequency	Temperature range	High protection level	DIN front bezel	LCD display	Lockable reset

Powerful

- High quality 8-digit LCD display with 8 mm high figures with optional backlighting.
- Counting modes include phase discriminator (quadrature) counting (also with pulse doubling) for connection to incremental encoders.
- Battery life approx. 8 years.
- Count frequency max. 6 kHz.
- High protection level IP65.

Simple

- Screw terminals, RM 5 mm.
- Reset key can be enabled via "Reset Enable" input.
- For positive or negative counting edge, depending on version.

Order code 6.133 . 012 . 8XX

a Backlighting
5 = without ¹⁾
6 = with

b Count input (input type: NPN/PNP ²⁾)

Input type	INP A			INP B				
0 = Quad/Quad ²⁾	0 ... 0.7 V DC	channel A	NPN	3 kHz	0 ... 0.7 V DC	channel B	NPN	3 kHz
1 ¹⁾ = Quad/Quad ²⁾	4 ... 30 V DC	channel A	PNP	6 kHz	4 ... 30 V DC	channel B	PNP	6 kHz

Delivery specification

- Counter
- Mounting clip
- Front bezel for screw mounting (T008181) 56 x 40 mm [2.20 x 1.57"], panel cut-out 50 x 25 mm [1.97 x 0.98"]
- Front bezel for clip mounting (T008180) 53 x 28 mm [2.09 x 1.10"], panel cut-out 50 x 25 mm [1.97 x 0.98"]
- Gasket
- Instruction manual, multilingual

1) Stock types
2) Phase discriminator for incremental encoders with x1 / x2 evaluation

Position displays

LCD position displays Phase discriminator (quadrature) x1 and x2 evaluation Codix 133

Accessories	Dimensions in mm [inch]	Order no.
Adapter front bezel, 72 x 36 [2.83 x 1.42]	for cut-out 68 x 33 [2.68 x 1.30] to cut-out 45 x 22.2 [1.77 x 0.87], for counters 48 x 24 [1.89 x 0.94], as set	black and silver anodised 162704 Set
Adapter front bezel, 48 x 48 [1.89 x 1.89]	for cut-out 45 x 45 [1.77 x 1.77] to cut-out 45 x 22.2 [1.77 x 0.87], with clip mounting for counters 48 x 24 [1.89 x 0.94]	black T008883
Adapter front bezel, 60 x 50 [2.36 x 1.97]	for cut-out 54 x 29 [2.13 x 1.14] to cut-out 45 x 22.2 [1.77 x 0.87], with screw mounting and gasket for counters 48 x 24 [1.89 x 0.94]	black N003001
Transparent cover, lockable, IP65	for cut-out 54 x 29 [2.13 x 1.14], for screw mounting to front bezel F1B or adapter front bezel N003001, for counters with cut-out 50 x 25 [1.97 x 0.98] or 45 x 22.2 [1.77 x 0.87]	N003002
Sealing cover type K1, IP65	suitable for front bezel 60 x 50 [2.36 x 1.97], for screw mounting of electromech. counters and via adapter front bezel N003001 for counters 48 x 24 [1.89 x 0.94]	G008301
Mounting frame with cut-out 50 x 25 [2.36 x 1.97] via separate adapter also for 45 x 22.2 [1.77 x 0.87]	for snap-on mounting on 35 [1.38] top-hat DIN rail, for counters 53 x 28 [2.09 x 1.10] and via separate adapter (T008180) for counters 48 x 24 [1.89 x 0.94]	chromated G300004

Suitable gaskets, other accessories and installation examples for optional accessories can be found in chapter accessories or in the accessories section under: www.kuebler.com/accessories.

Technical data

General technical data	
Display	LCD, 8 digits, 8 mm [0.32"] high
Backlighting	external electrical source 24 V DC \pm 20 %, 50 mA
Modes	phase discriminator x1 or x2 evaluation selectable
Display range	-9999999 ... 99999999, with overflow display
Reset	manual and electrical
Working temperature	-10°C ... +55°C [+14°F ... +131°F] (non-condensing)
Operating temperature	-10°C ... +60°C [+14°F ... +140°F] (non-condensing)
Storage temperature	-20°C ... +70°C [-4°F ... +158°F]

Electrical characteristics	
Power supply	internal lithium battery approx. 8 years at 20°C [68°F]
EMC standards	EN 55011 class B EN 61000-6-2, EN 61000-6-3
UL approval	file E128604

Mechanical characteristics	
Housing	dark grey RAL 7021
Protection	IP65 (front side)
Weight	approx. 50 g [1.76 oz]

Counting inputs		
Fast counting input max. 6 kHz (PNP), 3 kHz (NPN)		
Switching level NPN	LOW	0 ... 0.7 V
	HIGH	3 ... 30 V DC
Switching level PNP	LOW	0 ... 0.7 V
	HIGH	4 ... 30 V DC
Switching		x1 or x2 evaluation can be set via the mode input
Switching (mode)		
Contact input		Open Collector NPN (switching at 0 V DC)
Switching level NPN	LOW	0 ... 0.7 V
	HIGH	3 ... 5 V DC
Reset input		
Minimum pulse time	DC	50 ms
	high voltage	16 ms
Contact input DC – NPN	LOW	0 ... 0.7 V
	HIGH	3 ... 30 V DC
Electrical reset key locking		
Contact input		Open Collector NPN (switching at 0 V DC)
Switching level – NPN	LOW	0 ... 0.7 V
	HIGH	3 ... 5 V DC

Position displays

LCD position displays Phase discriminator (quadrature) x1 and x2 evaluation Codix 133

Terminal assignment

DC type: 6.133.012.8x0

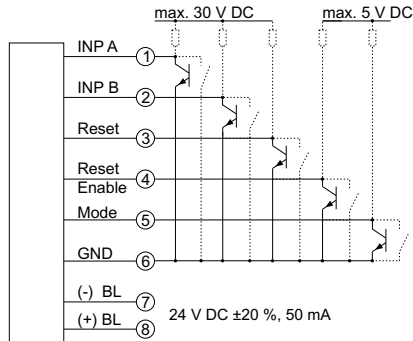

DC type: 6.133.012.8x1

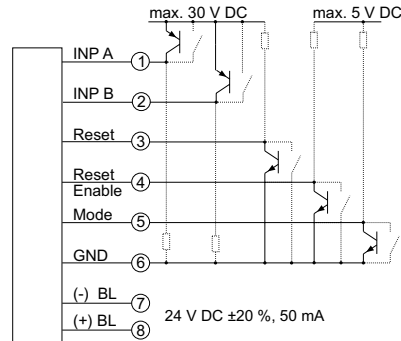

BL = backlighting

Dimensions

Dimensions in mm [inch]

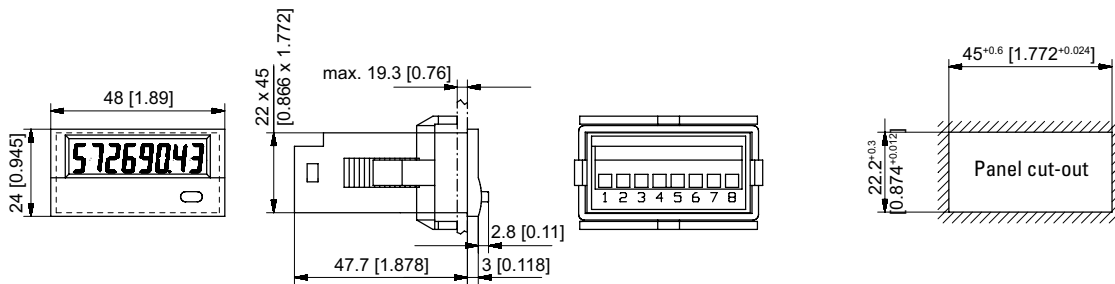

Front bezel for clip mounting (included in delivery)

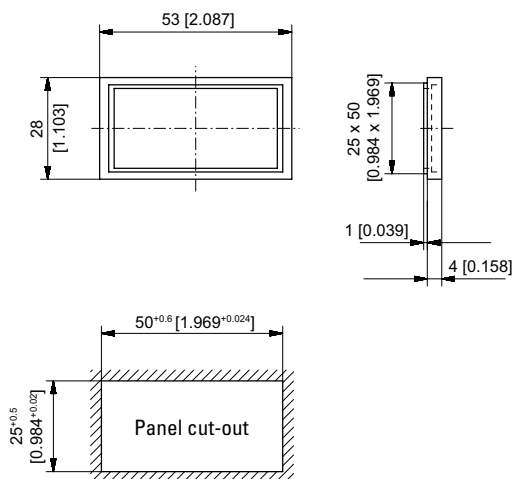

Front bezel for screw mounting (included in delivery)

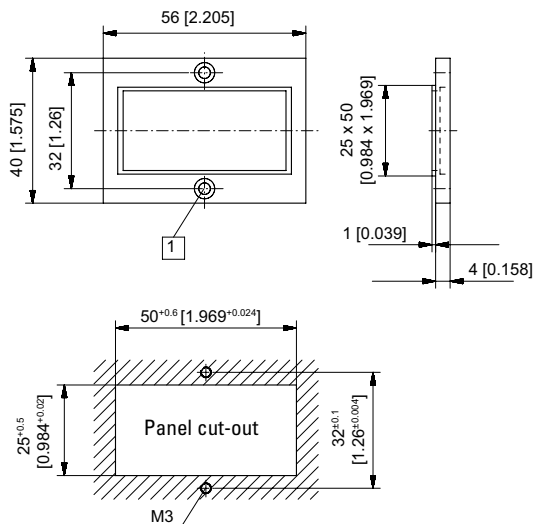

1 Countersinking Af3, DIN 74

Position displays with limits

LCD touch position preset counters SSI absolute encoder display (AC+DC) 570T



The fast SSI display type 570T is designed for absolute SSI encoders with a resolution up to 32 bits. It can be used as either a master or a slave display.

Thanks to simple bit assignment and bit blanking the display, which can be scaled and linearized, can also be cascaded, in order to extend the display range as desired. Output options include 4 limit values, analog output or RS232 or RS485 interface.



Product overview
Basics
Pulse counters
Preset counters
Hour meters
Timers
Frequency displays
Tachometers
Position displays
Multifunction devices
Energy meters
Process devices
Temperature devices
Strain-gauge controllers
Accessories
Index

AC 115... 230V Power supply	DC 18... 30 V Power supply	SSI SSI input	max. 1 MHz Count frequency	4 4 switching outputs	2 Relay output	mA, V Analog output	16 bit Resolution analog output	RS 232 / 485 RS232 / RS485 interface	IP65 High protection level	POSITION Position display
DIN 96 x 48 DIN front bezel	8 LCDs LCD touch display	Menu-driven programming	SSI Display linearization	Touch display	Operation with gloves					

Characteristics

- Suitable for SSI-protocols from 8 up to 32 bits.
- 4 switching outputs to work as limit or preset values (reaction time < 1 ms), also with programmable tracking preset.
- Scaleable analog output (reaction time < 1 ms), resolution 16 bit, -10 ... +10 V, 0 ... 20 mA or 4 ... 20 mA.
- Serial interface RS232 or RS485 for reading data in and out.
- Version with 2 relay outputs as limit values or presets; can also be programmed as tracking preset.
- Gray or binary code.
- 96 x 48 mm DIN-housing, IP65.

Benefits

- AC and DC power supply in one unit.
- Master- or slave mode.
- Screw terminal connection.
- SSI-clock frequency from 100 Hz up to 1 MHz.
- Display may be adjusted using scaling- and offset-features.
- Large 13 mm high LCD display, 8-digit, with adjustable brightness. Tri-color – red/green/yellow – programmable.
- Round-loop function.
- 24-point linearization.
- bit blanking.

Order code 6.570T . 01X . XXX

a Relay outputs
0 = 2 relay outputs
2 = without output

b Power supply
3 = 18 ... 30 V DC
E = 18 ... 30 V DC + 115 ... 230 V AC

c Further options
0 = standard
A = with wire break monitoring

d Electrical outputs
0 = none
1 = RS232, 4 switching outputs
2 = RS232, 4 switching outputs, analog output
3 = RS485, 4 switching outputs

Delivery specification
· Display 570T
· Gasket
· Mounting kit
· Manual German/English

Stock types
6.570T.012.301
6.570T.012.302
6.570T.010.302
6.570T.010.E02

Position displays with limits

LCD touch position preset counters		SSI absolute encoder display (AC+DC)	570T	Order no.
Accessories				
Mounting frame with cut-out 92 x 45 [3.62 x 1.77]	for snap-on mounting on 35 [1.38] top-hat DIN rail, for counters 96 x 48 [3.74 x 1.89]		grey	G300005
OS6.0 software for parameter setting	can be downloaded at www.kuebler.com			

Suitable gaskets as well as further accessories can be found in the accessories section or in the accessories area of our website at: www.kuebler.com/accessories.

Technical data

General technical data

Display	LCD touch display, 13 mm high 8 decades + sign
Operating temperature	-20°C ... +60°C [-4°F ... +140°F] (non-condensing)
Storage temperature	-25°C ... +70°C [-13°F ... +158°F]
Altitude	up to 2000 m [6562']

Electrical characteristics

Power supply	18 ... 30 V DC, with reverse polarity protection (rated voltage 24 V DC) 115 ... 230 V AC, 50/60 Hz (option)
Current consumption DC	100 mA, without load
Power consumption AC	approx. 3 VA, without load
Auxiliary power supply (for sensors) (in case of wire break monitoring, switchable from 24 V DC to 5 V DC / 250 mA)	AC supply 24 V DC ±15 %, 150 mA (up to +45°C) 80 mA (from +46°C) DC supply U _B - 1 V, 250 mA
EMC standards	EN 61000-6-2, EN 61000-6-3, EN 61000-6-4, EN 61326-3-2
Device safety	designed to EN 61010 part 1 protection class 2 application area pollution level 2

Mechanical characteristics

Housing	ABS UL94-V-0
Weight	approx. 200 g
Protection	IP65 (front side) IP20 (rear side)
Terminals	max. 1.5 mm ²

Inputs

SSI interface	clock frequency 100 Hz ... 1 MHz input level RS422: > 0.5 V load max. 3 mA / R _i > 10 kΩ / 47 pF
3 control inputs (Cnt 1 - 3)	PNP input frequency max. 10 kHz input level HTL: Low 0 ... 3 V / High 9 ... 30 V load max. 2 mA / R _i > 15 kΩ / 470 pF

Outputs (option)

4 switching outputs	5 ... 30 V DC/200 mA (PNP) reaction time < 1 ms
Interface	RS232 or RS485 Drivecom protocol / Modbus / Printer 9600 ... 38400 Baud
Analog output	-10 ... +10 V (max. 2 mA) or 0 ... 20 mA, 4 ... 20 mA (max. 270 Ω) resolution 16 bit (15 bit + sign) accuracy ±0.1 % reaction time < 1 ms
Relay output	2 changeover contacts (potential free) max. 250 V AC / 3 A / 750 VA max. 150 V DC / 2 A / 50 W reaction time < 20 ms

Product overview
Basics

Pulse counters

Preset counters

Hour meters
Timers

Frequency displays
Tachometers

Position displays

Multifunction
devices

Energy meters

Process devices

Temperature
devices

Strain-gauge
controllers

Accessories
Index

Position displays with limits

LCD touch position preset counters	SSI absolute encoder display (AC+DC)	570T
---	---	-------------

Terminal assignment

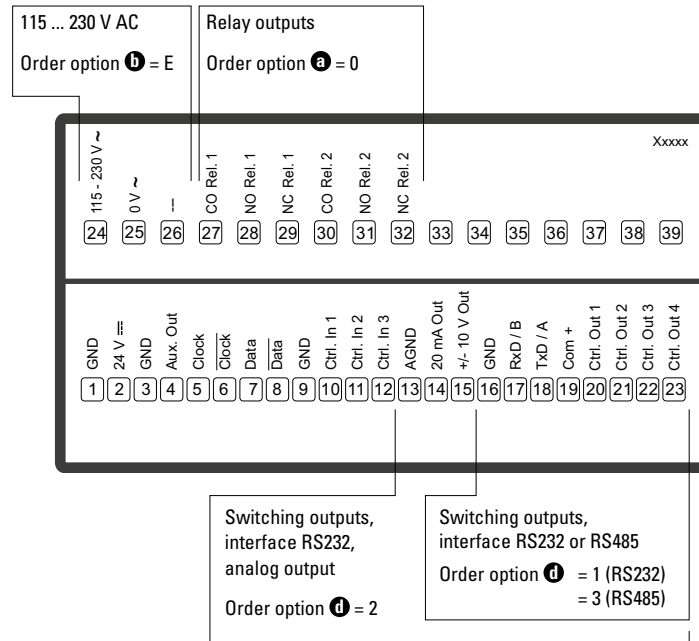

Dimensions

Dimensions in mm [inch]

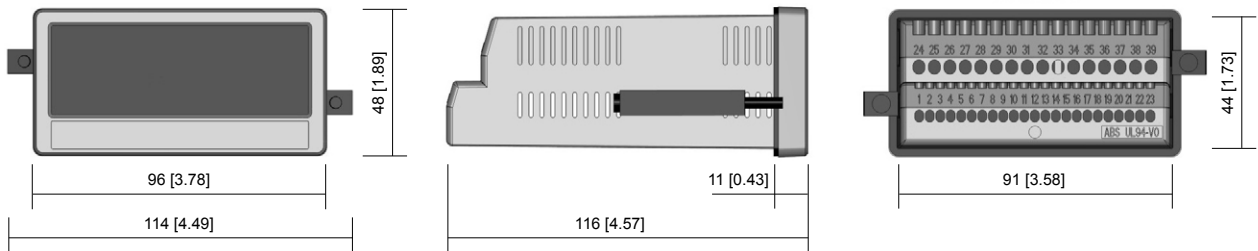

Panel cut-out
92 x 45 mm [3.62 x 1.77"]



Product overview
Basics

Pulse counters

Preset counters

Hour meters
Timers

Frequency displays
Tachometers

Position displays

Multifunction
devices

Energy meters



Process devices

Temperature
devices

Strain-gauge
controllers

Accessories
Index

Multifunction devices

Multifunction devices, electronic		Type	Page
LED multifunction displays	Multifunctional – pulse, frequency, time (DC)	Codix 524	240
	Multifunctional – pulse, frequency, time (AC+DC)	Codix 544	244
LCD multifunction preset counters	 1 preset – pulse, time (battery)	Codix 901	120
	1 or 2 presets – pulse, time – 5 kHz (AC+DC)	Codix 907 / 908	124
	Multifunctional – pulse, frequency, time – 1 ... 6 presets (AC+DC)	Codix 923 / 924	127
Multifunction preset counters with multicolor or LED look	Multifunctional – pulse, frequency, time – 1 ... 6 presets (AC+DC)	Codix 923 / 924	127
LED multifunction preset counters	Multifunctional – pulse, frequency, time – 65 kHz, 2 presets (AC+DC)	Codix 560	134
LCD touch multifunction preset counter	 Pulse, frequency, time (also reciprocal) – (AC+DC)	571T	247
LED dual function displays	Universal with dual functions, 4 combinations (DC)	Codix 52U	250
	6 count modes with tachometer (DC)	Codix 52P	254
	2 counters with separate scaling (DC)	Codix 52T	66
	2 counters with separate inputs and separate scaling (DC)	Codix 52C	69
	Universal with dual functions, 4 combinations (AC+DC)	Codix 54U	258
	6 count modes with tachometer (AC+DC)	Codix 54P	261
Multifunction devices, electromechanical		Type	Page
Dual function counters	Pulse + time / 2 x time (AC+DC)	HC 77	208
	Pulse + time for DIN rail (AC+DC)	SHC 77	211
	Energy + time (AC)	HW 66 / HW 66 M	266

Product overview
Basics

Pulse counters

Preset counters

Hour meters
Timers

Frequency displays
Tachometers

Position displays

Multifunction
devices

Energy meters

Process devices

Temperature
devices

Strain-gauge
controllers

Accessories
Index

LED multifunction display

Multifunctional – pulse, frequency, time (DC)

Codix 524



The Codix 524 is a voltage-powered multifunction counter with 4 functions in one device:
Pulse, position, frequency and speed display, timer and short time meter.
 With 6-digit LED display for NPN / PNP input signals.



DC 10 ... 30 V Power supply	000000 DIN 48 x 24 DIN front bezel	-20°...+65°C Temperature range	IP65 High protection level	PROG Menu-driven programming	max. 60 kHz Pulse counter/ Totalizer	POSITION Position display	1/sec 1/min Frequency meter/ tachometer	Timer	t Hz HRA Frequency meter HRA
--	---	--	--------------------------------------	--	---	-------------------------------------	---	--------------	---

Powerful

- Fast count and frequency input – input frequency max. 60 kHz (can be damped to 30 Hz for mechanical contacts).
- Robust housing – IP65 protected.
- Very bright LED display, 8 mm high, 6 digits.
- Very accurate precise frequency measurement principle (HRA-High Rate Accuracy System)
 Frequencies up to 38 Hz are calculated using time-interval (period duration) measurement. Frequencies > 38 Hz are calculated using a special time base (gate time) measurement. A very high accuracy of < 0.1 % is achieved, even with very short gate times. The resulting measurement is available after a max. of 50 ms.
- Short start-up time – detects input pulses just 16 msec after being switched on => no pulses are lost with a simultaneous motor start-up.

User-friendly and universal

- Large keys – can also be operated when wearing gloves.
- Programming:
 - Simple uniform menu-driven programming and operation.
 - Possible to enter the programming also during operation with a confirmation prompt.
- Individually programmable scaling: Multiplication and division factor (0.0001...99.9999), to display corresponding engineering units, e.g. position in 1/10 mm and speed in RPM.
- 4 different count input modes: 2-channel count input for detecting count direction, difference or adding mode, quadrature with x1, x2 or x4 evaluation.
- Frequency measurement: display in 1/min or 1/sec.
- Time counting: pulse width or time interval measurement in hours, minutes or seconds, as well as real-time display.
- Inputs: as an alternative to the HTL inputs, devices are available with a 4 ... 30 V DC input level, for use as parallel displays to PLCs.
- Optional output: zero signal for position and count, zero speed monitoring, 1 Hz clock pulse for active time measurement.

Order code

6.524 . 01 X . 3 X 0
a b

- a** Output
 1 = optocoupler ¹⁾
 2 = no output ¹⁾

- b** Input switching level
 0 = Standard (HTL) ¹⁾
 A = 4 ... 30 V DC

Delivery specification

- Counter
- Mounting clip
- Front bezel for screw mounting (T008181) 56 x 40 mm [2.20 x 1.57"], panel cut-out 50 x 25 mm [1.97 x 0.98"]
- Front bezel for clip mounting (T008180) 53 x 28 mm [2.09 x 1.10"], panel cut-out 50 x 25 mm [1.97 x 0.98"]
- Gasket
- Instruction manual, multilingual

1) Stock types

Multifunction devices, electronic

LED multifunction display	Multifunctional – pulse, frequency, time (DC)	Codix 524	
Accessories	Dimensions in mm [inch]	Order no.	
Adapter front bezel, 72 x 36 [2.83 x 1.42]	for cut-out 68 x 33 [2.68 x 1.30] to cut-out 45 x 22.2 [1.77 x 0.87], for counters 48 x 24 [1.89 x 0.94], as set	black and silver anodised	162704 Set
Adapter front bezel, 48 x 48 [1.89 x 1.89]	for cut-out 45 x 45 [1.77 x 1.77] to cut-out 45 x 22.2 [1.77 x 0.87], with clip mounting for counters 48 x 24 [1.89 x 0.94]	black	T008883
Adapter front bezel, 60 x 50 [2.36 x 1.97]	for cut-out 54 x 29 [2.13 x 1.14] to cut-out 45 x 22.2 [1.77 x 0.87], with screw mounting and gasket for counters 48 x 24 [1.89 x 0.94]	black	N003001
Transparent cover, lockable, IP65	for cut-out 54 x 29 [2.13 x 1.14], for screw mounting to front bezel F1B or adapter front bezel N003001, for counters with cut-out 50 x 25 [1.97 x 0.98] or 45 x 22.2 [1.77 x 0.87]		N003002
Sealing cover type K1, IP65	suitable for front bezel 60 x 50 [2.36 x 1.97], for screw mounting of electromech. counters and via adapter front bezel N003001 for counters 48 x 24 [1.89 x 0.94]		G008301
Mounting frame with cut-out 50 x 25 [2.36 x 1.97] via separate adapter also for 45 x 22.2 [1.77 x 0.87]	for snap-on mounting on 35 [1.38] top-hat DIN rail, for counters 53 x 28 [2.09 x 1.10] and via separate adapter (T008180) for counters 48 x 24 [1.89 x 0.94]	chromated	G300004

Suitable gaskets, other accessories and installation examples for optional accessories can be found in chapter accessories or in the accessories section under: www.kuebler.com/accessories.

Technical data

General technical data		Inputs	
Display	6 digits, red 7 segment LED display; 8 mm high	Polarity of inputs	programmable, NPN or PNP
Data backup	EEPROM	Input resistance	approx. 5 kΩ
Operating temperature	10 ... 26 V DC -20°C ... +65°C [-4°F ... +149°F] > 26 ... 30 V DC -20°C ... +55°C [-4°F ... +131°F] (non-condensing)	Counting frequency ¹⁾	max. 60 kHz, can be damped to 30 Hz for position display max. 25 kHz
Storage temperature	-25°C ... +70°C [-13°F ... +158°F]	Display range	timer 0.001 s ... 999999 h frequency meter 1/min or 1/sec
Electrical characteristics		Minimum pulse duration of the reset input	5 ms
Power supply	10 ... 30 VDC, with reverse polarity protection	Input switching level (HTL)	LOW 0 ... 0.2 x U _B [V DC] HIGH 0.6 x U _B ... 30 V DC
Current consumption	max. 55 mA	Input switching level at 4 ... 30 V DC	LOW 0 ... 2 V DC HIGH 4 ... 30 V DC
EMC standards	EN 55011 class B, EN 61000-6-2, EN 61000-6-3 EN 61326-1	Accuracy	tachometer < 0.1 % timer < 50 ppm
UL approval	file E128604	Outputs (optional)	
Mechanical characteristics		Optocoupler output	max. 30 V, 10 mA
Housing	front panel mount 48x24 mm acc. to DIN 43700; RAL 7021, dark grey		
Protection	IP65 (front side)		
Weight	approx. 50 g [1.76 oz]		
Vibration resistance acc. to EN 60068-2-6	10 ... 55 Hz / 1 mm [0.04"] / 30 min		
Shock resistance acc. to EN 60068-2-27	100 G: 2 ms 10 G: 6 ms		

1) Details see manual

Product overview
Basics
Pulse counters
Preset counters
Hour meters
Timers
Frequency displays
Tachometers
Position displays
Multifunction
devices
Energy meters
Process devices
Temperature
devices
Strain-gauge
controllers
Accessories
Index

Multifunction devices, electronic

LED multifunction display	Multifunctional – pulse, frequency, time (DC)	Codix 524
----------------------------------	--	------------------

Applications for multifunction display

- Counting tasks such as quantity and piece counting, measuring and recording of speed and of operating and processing times
- Piece counting or tool-life measurement on die cutters, presses, extruders, woodworking machines, drilling machines, pick-and-place machines, guillotines, special-purpose vehicles etc.
- Positioning tasks on processing machines, such as sawing machines, milling machines, bending and folding machines, etc.
- Production data acquisition by means of piece counting (using difference or adding), or measurement of production times or production speeds
- Totalizing flow, quantity and other scaleable media, or display of current flow rates

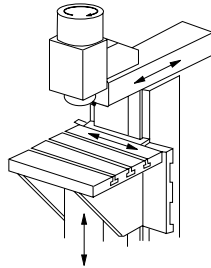

Position or rotary speed on milling machine

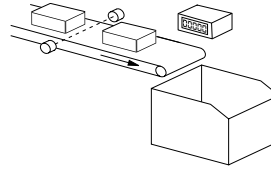

Piece count on conveyor or production speed

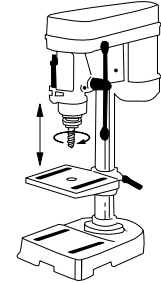

Drilling machine head, speed or drilling depth

Functions

Pulse counter:

Various counting modes such as count direction, difference, addition, phase discriminator

Position display:

Phase discriminator with simple, double or quadruple evaluation

Frequency and speed display:

Pulses per minute or per second scaleable, with HRA measurement

Hour meters and short-time meters:

Various programmable time ranges with different ways of measuring

Block diagram

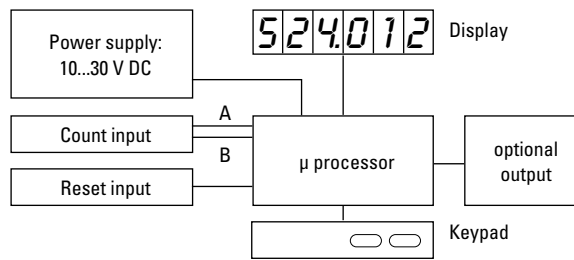

Terminal assignment

1	2	3	4	5
□	□	□	□	□

1	2	3	4	5	6	7
□	□	□	□	□	□	□

PIN without optocoupler	
1	10 ... 30 V DC
2	0 V GND
3	INP A
4	INP B
5	Reset / Set

PIN with optocoupler (NPN)	
1	10 ... 30 V DC
2	0 V GND
3	INP A
4	INP B
5	Reset / Set
6	Emitter
7	Collector

Multifunction devices, electronic

LED multifunction display **Multifunctional – pulse, frequency, time (DC)** **Codix 524**

Dimensions

Dimensions in mm [inch]

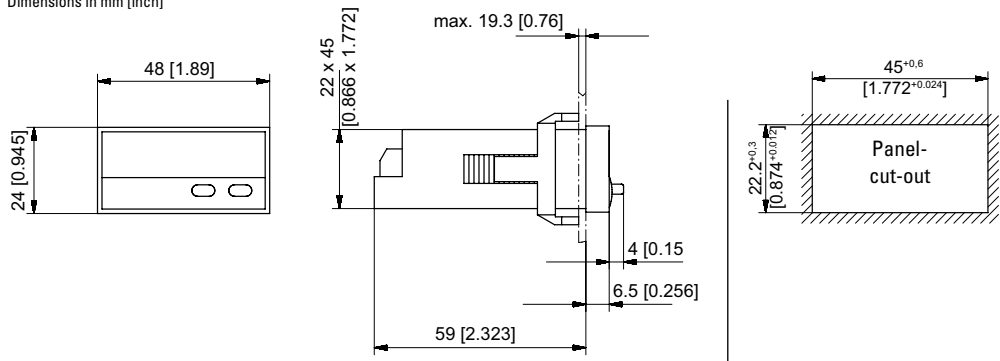

Front bezel for clip mounting (included in delivery)

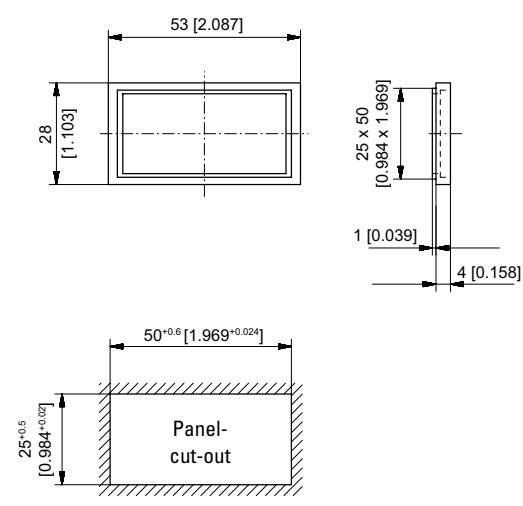

Front bezel for screw mounting (included in delivery)

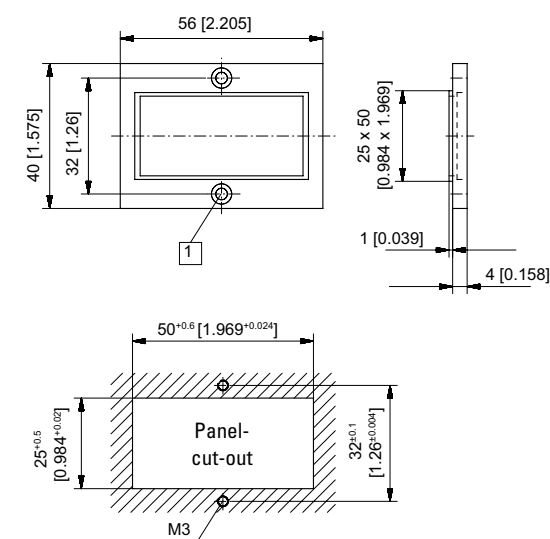

1 Countersinking Af3, DIN 74

- Product overview Basics
- Pulse counters
- Preset counters
- Hour meters Timers
- Frequency displays Tachometers
- Position displays
- Multifunction devices
- Energy meters
- Process devices
- Temperature devices
- Strain-gauge controllers
- Accessories Index



The Codix 544 is a voltage-powered multifunction counter with 4 functions in one device:

Pulse, position, frequency and speed display, timer and short time meter.

With 6-digit LED display for NPN, PNP input signals.



Powerful

- Fast count and frequency input – input frequency max. 60 kHz (can be damped to 30 Hz for mechanical contacts).
- Robust housing – IP65 protected.
- Very bright LED display, 14 mm high, 6 digits.
- Very accurate precise frequency measurement principle (HRA-High Rate Accuracy System)
Frequencies up to 38 Hz are calculated using time-interval (period duration) measurement. Frequencies > 38 Hz are calculated using a special time base (gate time) measurement. A very high accuracy of < 0.1 % is achieved, even with very short gate times. The resulting measurement is available after a max. of 50 ms.
- Short start-up time – detects input pulses just 16 msec after being switched on => no pulses are lost with a simultaneous motor start-up.

User-friendly and universal

- Large keys – can also be operated when wearing gloves.
- Programming:
 - Simple uniform menu-driven programming and operation.
 - Possible to enter the programming also during operation with a confirmation prompt.
- Individually programmable scaling: multiplication and division factor (0.0001...99.9999), to display corresponding engineering units, e.g. position in 1/10 mm and speed in RPM.
- 4 different count input modes: 2-channel count input for detecting count direction, difference or adding mode, quadrature with x1, x2 or x4 evaluation.
- Frequency measurement: display in 1/min or 1/sec.
- Time counting: pulse width or time interval measurement in hours, minutes or seconds, as well as real-time display.
- AC or DC power supply.
- Inputs: as an alternative to the HTL inputs, devices are available with a 5 V DC input level, for use as parallel displays to PLCs.
- Optional output: zero signal for position and count, zero speed monitoring, 1 Hz clock pulse for active time measurement.

Order code

6.544 . 01 X . XX 0
a b c

a Output

- 1 = optocoupler
- 2 = no output ¹⁾

b Power supply

- 0 = 100 ... 240 V AC, ±10 % ¹⁾
- 3 = 10 ... 30 V DC ¹⁾

c Input switching level

- 0 = Standard (HTL) ¹⁾
- A = 4 ... 30 V DC

Delivery specification

- Digital display
- Mounting clip
- Gasket
- 2 plug-in screw terminals
- Instruction manual, multilingual

Replacement parts

- 7 pin screw terminal RM 3.81 1 ... 7: N100387
- 2 pin screw terminal RM 5.08 1 ... 2: N100133

1) Stock types

Multifunction devices, electronic

LED multifunction display Multifunctional – pulse, frequency, time (AC+DC) Codix 544

Accessories	Dimensions in mm [inch]	Order no.
Mounting frame with cut-out 92 x 45 [3.62 x 1.77]	for snap-on mounting on 35 [1.38] top-hat DIN rail, for counters 96 x 48 [3.74 x 1.89]	grey G300005

Suitable gaskets as well as further accessories can be found in the accessories section or in the accessories area of our website at: www.kuebler.com/accessories.

Technical data

General technical data	
Display	6 digit, red 7 segment LED display; 14 mm [0.55"] high
Data backup	EEPROM
Operating temperature	-20°C ... +65°C [-4°F ... +149°F] (non-condensing)
Storage temperature	-25°C ... +70°C [-13°F ... +158°F]
Altitude	up to 2000 m [6562']

Electrical characteristics	
Power supply	10 ... 30 VDC, with integrated reverse polarity protection 100 ... 240 V AC, ±10 %
Current consumption	max. 50 mA, 6 VA
EMC standards	EN 55011 class B, EN 61000-6-2, EN 61000-6-3
Device safety	designed to protection class 2 application area pollution level 2
UL approval	file E128604

Mechanical characteristics	
Housing	front panel mount 96 x 48 mm [3.74 x 1.89"] acc. to DIN 43700; RAL 7021, dark grey
Protection	IP65 (front side)
Weight	approx. 150 g [5.29 oz]

Inputs	
Polarity of inputs	programmable, NPN or PNP for all inputs
Input resistance	approx. 5 kΩ
Counting frequency ¹⁾	max. 60 kHz, can be damped to 30 Hz for position display max. 25 kHz
Display range	timer 0.001 s ... 999999 h frequency meter 1/min or 1/sec
Minimum pulse duration of the reset input	5 ms
Input switching level standard version (HTL)	
DC power supply	LOW 0 ... 0.2 x U _B [V DC] HIGH 0.6 x U _B ... 30 V DC
AC-power supply	LOW 0 ... 4 V DC HIGH 12 ... 30 V DC
Input switching level at 4 ... 30 V DC	
	LOW 0 ... 2 V DC HIGH 4 ... 30 V DC
Accuracy	tachometer < 0.1 % timer < 50 ppm

Outputs	
Sensor power supply (AC version)	24 V DC ±15 %/100 mA
Optocoupler output	max. 30 V, 10 mA

Applications for multifunction display

- Counting tasks such as quantity and piece counting, measuring and recording of speed and of operating and processing times
- Piece counting or tool-life measurement on die cutters, presses, extruders, woodworking machines, drilling machines, pick-and-place machines, guillotines, special-purpose vehicles etc.
- Positioning tasks on processing machines, such as sawing machines, milling machines, bending and folding machines, etc.
- Production data acquisition by means of piece counting (using difference or adding), or measurement of production times or production speeds
- Totalizing flow, quantity and other scaleable media, or display of current flow rates.

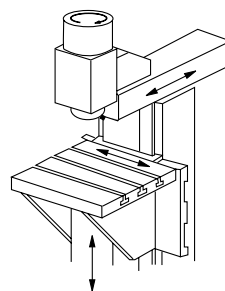

Position or rotary speed on milling machine

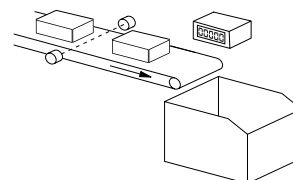

Piece count on conveyor or production speed

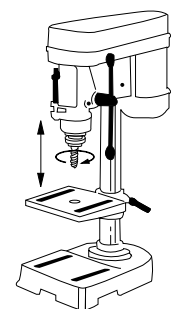

Drilling machine head, speed or drilling depth

1) Details see manual

Multifunction devices, electronic

LED multifunction display Multifunctional – pulse, frequency, time (AC+DC) Codix 544

Functions

Pulse counter:

Various counting modes such as count direction, difference, addition, phase discriminator

Position display:

Phase discriminator with simple, double or quadruple evaluation

Frequency and speed display:

Pulses per minute or per second scaleable, with HRA measurement

Hour meters and short-time meters:

Various programmable time ranges with different ways of measuring

Block diagram

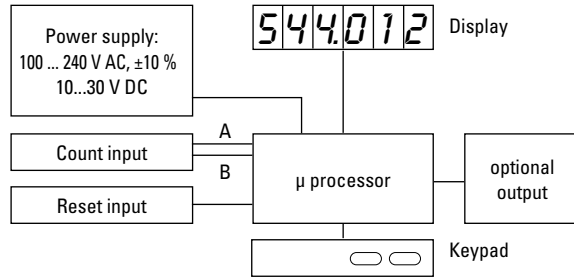

Terminal assignment

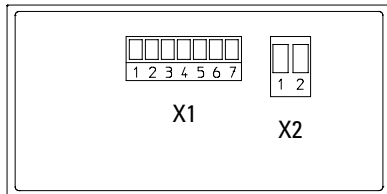

Connection X1

PIN	AC version	DC version
1	Optocoupler output	Emitter
2	Optocoupler output	Collector
3	Reset / Set	
4	INP B	
5	INP A	
6	GND out	n.c.
7	+24 V out	n.c.

Connection X2

PIN	AC version	DC version
1	100 ... 240 V AC, ±10 %	0VDC (GND)
2	100 ... 240 V AC, ±10 %	10...30 V DC

Dimensions

Dimensions in mm [inch]

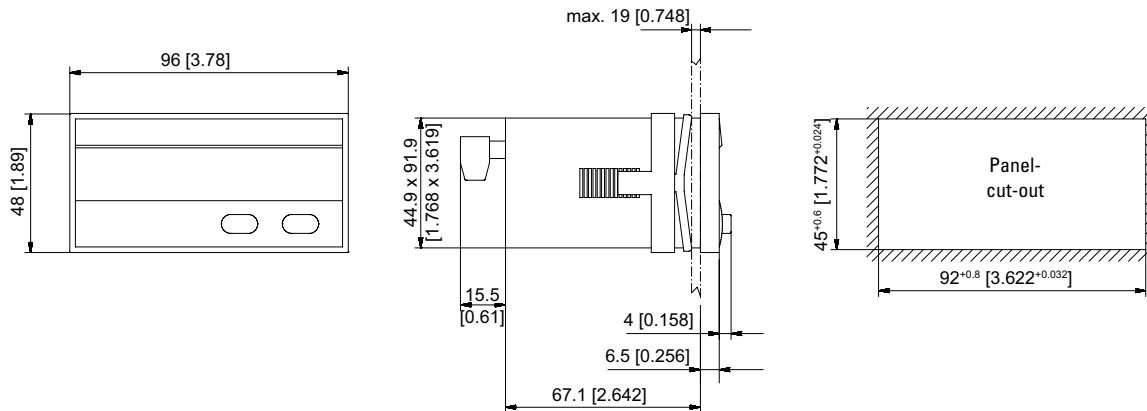

LCD touch multifunction preset counters Pulse, frequency, time (also reciprocal) – (AC+DC) 571T



The multifunction preset counter 571T with its max. 250 kHz count frequency is ideal for fast counting tasks. It can also be used as a tachometer, short time meter, stop-watch or to measure machine cycle times or throughput times.

Output options include 4 limit values, analog output and RS232 or RS485 interface.

This device is thus able to carry out virtually all count, measurement and control tasks.

Product overview
Basics
Pulse counters
Preset counters
Hour meters
Timers
Frequency displays
Tachometers
Position displays
Multifunction devices
Energy meters
Process devices
Temperature devices
Strain-gauge controllers
Accessories
Index

AC 115... 230V Power supply	DC 18... 30 V Multifunctional	 max. 1 MHz Input frequency (RS422)	 4 4 switching outputs	 2 Relay output	 mA, V Analog output	 16 bit Resolution analog output	 RS 232 / 485 RS232 / RS485 interface	 IP65 High protection level	 POSITION Position display
 DIN 96 x 48 DIN front bezel	 8 LCDs LCD touch display	 Menu-driven programming	 Touch display	 Operation with gloves					

Characteristics

- Fast count input, works with our Limes measuring system (250 kHz/HTL, 1 MHz/RS422).
- 4 switching outputs to work as limit values (reaction time < 1 ms).
- Scalable analog output (reaction time < 1 ms), resolution 16 bit, -10 ... +10 V, 0 ... 20 mA or 4 ... 20 mA.
- Serial interface RS232 or RS485 for reading data in and out.
- Sensor power supply 24 V DC / 150 mA (AC version) or U_B - 1 V / max. 250 mA (DC version).
- 96 x 48 mm DIN housing, IP65.
- Touch display with 8-digit display value and menu-driven programming.
- 2 relay outputs that can be assigned to the limit values.

Benefits

- AC and DC power supply in one unit.
- Measuring function can be programmed for RPM, speed, speed from elapsed time, machine cycle time, throughput time (reciprocal rotary speed), as well as numerous count and stop-watch functions.
- 4 switching outputs; can also be programmed as a tracking preset.
- Freely programmable.
- Large 13 mm high LCD display, 8-digit, with adjustable brightness. Tri-color – red / green / yellow – programmable.
- Display linearization with teach function.

Order code

6.571T . 01 X . XXX

a
b
c
d

a Relay outputs
0 = 2 relay outputs
2 = without output

b Power supply
3 = 18 ... 30 V DC
E = 18 ... 30 V DC + 115 ... 230 V AC

c Further options
0 = HTL count inputs (standard)
A = RS422 / HTL differential / HTL count inputs (option)

d Electrical outputs
0 = none
1 = RS232, 4 switching outputs
2 = RS232, 4 switching outputs, analog output
3 = RS485, 4 switching outputs

Delivery specification
· Display 571T
· Gasket
· Mounting kit
· Manual German/English

Stock types
6.571T.012.301
6.571T.012.302
6.571T.010.302
6.571T.010.E02

Multifunction devices, electronic

LCD touch multifunction preset counters Pulse, frequency, time (also reciprocal) – (AC+DC) 571T

Accessories		Order no.
Mounting frame with cut-out 92 x 45 [3.62 x 1.77]	for snap-on mounting on 35 [1.38] top-hat DIN rail, for counters 96 x 48 [3.74 x 1.89]	grey G300005
OS6.0 software for parameter setting	can be downloaded at www.kuebler.com	

Suitable gaskets as well as further accessories can be found in the accessories section or in the accessories area of our website at: www.kuebler.com/accessories.

Technical data

General technical data

Display	LCD touch display, 13 mm high 8 decades + sign
Operating temperature	-20°C ... +60°C [-4°F ... +140°F] (non-condensing)
Storage temperature	-25°C ... +70°C [-13°F ... +158°F]
Altitude	up to 2000 m [6562']

Electrical characteristics

Power supply	18 ... 30 V DC, with reverse polarity protection (rated voltage 24 V DC) 115 ... 230 V AC, 50/60 Hz (option)
Current consumption DC	100 mA, without load
Power consumption AC	approx. 3 VA, without load
Auxiliary voltage for sensors (with RS 422 switchable from 24 V DC to 5 V DC / 250 mA)	AC supply 24 V DC ±15 %, 150 mA (up to +45°C) 80 mA (from +46°C) DC supply $U_B - 1 V$, 250 mA
EMC standards	EN 61000-6-2, EN 61000-6-3, EN 61000-6-4, EN 61326-3-2
Device safety	designed to protection class application area EN 61010 part 1 2 pollution level 2

Mechanical characteristics

Housing	ABS UL94-V-0
Weight	approx. 200 g
Protection	IP65 (front side) IP20 (rear side)
Terminals	max. 1.5 mm ²

Inputs

2 incremental inputs (A, B) HTL (standard)	pulse input frequency input level load	Tri-State, PNP, NPN and Namur max. 250 kHz Low: 0 ... 3 V / High: 9 ... 30 V max. 6 mA / $R_i > 5 k\Omega$ / 470 pF
4 incremental inputs (A, /A, B, /B) RS422 / HTL differential / HTL PNP-NPN (option)	input frequency input level load	RS422: max. 1 MHz HTL differential: max. 500 kHz HTL: max. 250 kHz RS422: > 0.5 V HTL differential: > 2 V HTL: Low 0 ... 3 V / High 9 ... 30 V max. 3 mA / $R_i > 10 k\Omega$ / 47 pF
3 control inputs (Cnt 1 - 3)	input frequency input level load	PNP max. 10 kHz HTL: Low 0 ... 3 V / High 9 ... 30 V max. 2 mA / $R_i > 15 k\Omega$ / 470 pF
Accuracy frequency		±1 ppm ±1 digit

Outputs (option)

4 switching outputs	reaction time	5 ... 30 V DC/200 mA (PNP) < 1 ms
Interface		RS232 or RS485 Drivecom protocol / Modbus / Printer 9600 ... 38400 Baud
Analog output	resolution accuracy reaction time	-10 ... +10 V (max. 2 mA) or 0 ... 20 mA, 4 ... 20 mA (max. 270 Ω) 16 bit (15 bit + sign) ±0.1 % < 1 ms
Relay output	reaction time	2 changeover contacts (potential free) max. 250 V AC / 3 A / 750 VA max. 150 V DC / 2 A / 50 W < 20 ms

Product overview
Basics

Pulse counters

Preset counters

Hour meters
Timers

Frequency displays
Tachometers

Position displays

Multifunction
devices

Energy meters

Process devices

Temperature
devices

Strain-gauge
controllers

Accessories
Index

Multifunction devices, electronic

LCD touch multifunction preset counters **Pulse, frequency, time (also reciprocal) – (AC+DC) 571T**

Terminal assignment HTL (standard)

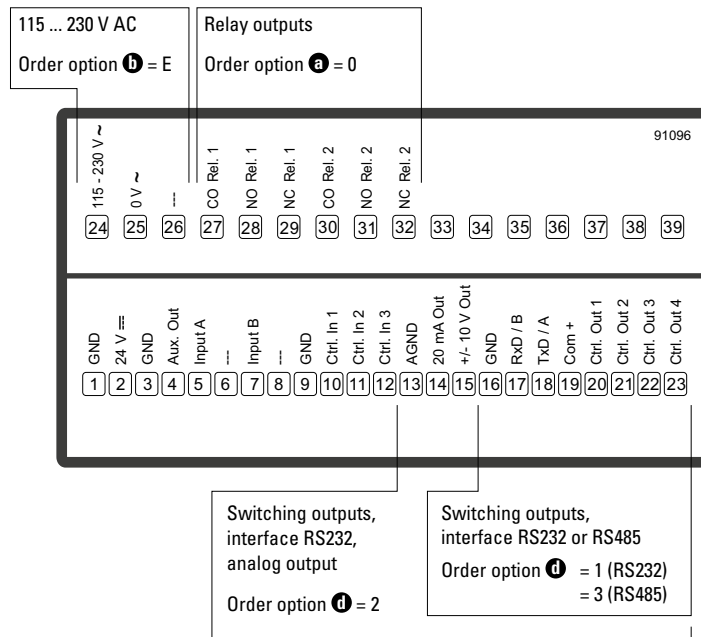

Terminal assignment RS422 / HTL differential / HTL (option)

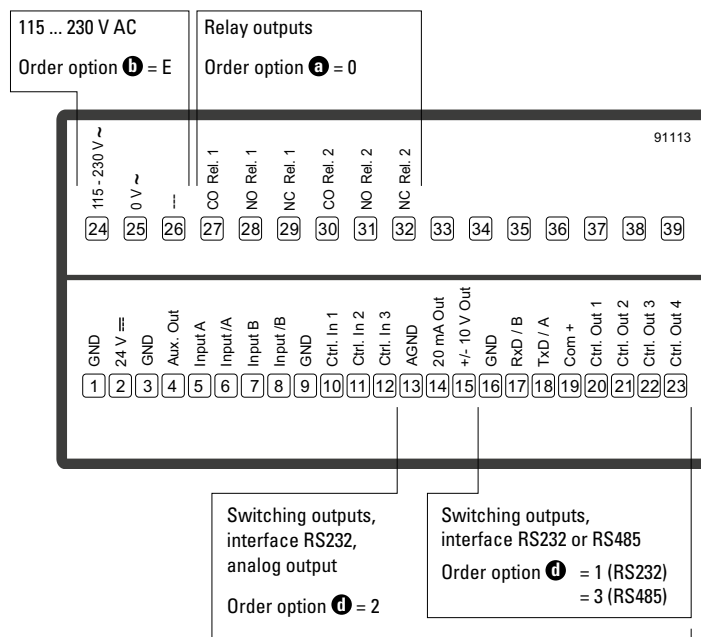

Dimensions

Dimensions in mm [inch]

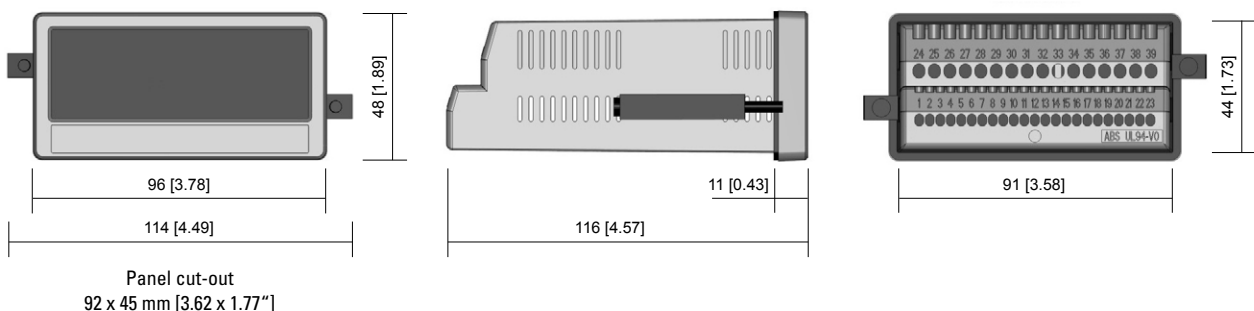

LED dual function displays

Universal with dual functions, 4 combinations (DC)

Codix 52U



The Codix 52U is a voltage-powered dual function counter with 4 functions in one device:

Counter with 2 totalizing ranges, totalizer and timer, totalizer and frequency meter, timer with 2 time ranges.

For fast and slow count pulses, with 6-digit LED display for NPN, PNP input signals.



Power supply



DIN front bezel

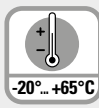

Temperature range



High protection level



Menu-driven programming

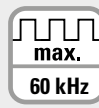

Pulse counter/ Totalizer



Frequency meter/ tachometer



Timer



Frequency meter HRA

Powerful

- Fast count and frequency input – input frequency max. 60 kHz (can be damped to 30 Hz for mechanical contacts).
- Robust housing – IP65 protected.
- Very bright LED display, 8 mm high, 6 digits.
- Very accurate precise frequency measurement principle (HRA-High Rate Accuracy System)
Frequencies up to 38 Hz are calculated using time-interval (period duration) measurement. Frequencies > 38 Hz are calculated using a special time base (gate time) measurement. A very high accuracy of < 0.1 % is achieved, even with very short gate times. The resulting measurement is available after a max. of 50 ms.
- Short start-up time – detects input pulses just 16 msec after being switched on => no pulses are lost with a simultaneous motor start-up.

User-friendly and universal

- Large keys – can also be operated when wearing gloves.
- Programming:
 - Simple uniform menu-driven programming and operation.
 - Possible to enter the programming also during operation with a confirmation prompt.
 - Pressing the right key switches between displays.
- Individually programmable scaling: multiplication and division factor (0.0001...99.9999), to display corresponding engineering units, e.g. position in 1/10 mm and speed in RPM.
- Separate factors for frequency- and pulse counting.
- Inputs: as an alternative to the HTL inputs, devices are available with a 4 ... 30 V DC input level, for use as parallel displays to PLCs.
- Timer specials: timer or hours-run meter with various Start/Stop measurements, time range settings in hours, minutes or seconds, with decimal point. Resolutions up to 1/1000 can be programmed.

Order code

6.52U . 01 2 . 3 X 0

- a** Input switching level
 0 = Standard (HTL) ¹⁾
 A = 4 ... 30 V DC

Delivery specification

- Counter
- Mounting clip
- Front bezel for screw mounting (T008181) 56 x 40 mm [2.20 x 1.57"], panel cut-out 50 x 25 mm [1.97 x 0.98"]
- Front bezel for clip mounting (T008180) 53 x 28 mm [2.09 x 1.10"], panel cut-out 50 x 25 mm [1.97 x 0.98"]
- Gasket
- Instruction manual, multilingual

1) Stock types

Multifunction devices, electronic

LED dual function displays	Universal with dual functions, 4 combinations (DC)	Codix 52U	
Accessories	Dimensions in mm [inch]	Order no.	
Adapter front bezel, 72 x 36 [2.83 x 1.42]	for cut-out 68 x 33 [2.68 x 1.30] to cut-out 45 x 22.2 [1.77 x 0.87], for counters 48 x 24 [1.89 x 0.94], as set	black and silver anodised	162704 Set
Adapter front bezel, 48 x 48 [1.89 x 1.89]	for cut-out 45 x 45 [1.77 x 1.77] to cut-out 45 x 22.2 [1.77 x 0.87], with clip mounting for counters 48 x 24 [1.89 x 0.94]	black	T008883
Adapter front bezel, 60 x 50 [2.36 x 1.97]	for cut-out 54 x 29 [2.13 x 1.14] to cut-out 45 x 22.2 [1.77 x 0.87], with screw mounting and gasket for counters 48 x 24 [1.89 x 0.94]	black	N003001
Transparent cover, lockable, IP65	for cut-out 54 x 29 [2.13 x 1.14], for screw mounting to front bezel F1B or adapter front bezel N003001, for counters with cut-out 50 x 25 [1.97 x 0.98] or 45 x 22.2 [1.77 x 0.87]		N003002
Sealing cover type K1, IP65	suitable for front bezel 60 x 50 [2.36 x 1.97], for screw mounting of electromech. counters and via adapter front bezel N003001 for counters 48 x 24 [1.89 x 0.94]		G008301
Mounting frame with cut-out 50 x 25 [2.36 x 1.97] via separate adapter also for 45 x 22.2 [1.77 x 0.87]	for snap-on mounting on 35 [1.38] top-hat DIN rail, for counters 53 x 28 [2.09 x 1.10] and via separate adapter (T008180) for counters 48 x 24 [1.89 x 0.94]	chromated	G300004

Suitable gaskets, other accessories and installation examples for optional accessories can be found in chapter accessories or in the accessories section under: www.kuebler.com/accessories.

Technical data

General technical data	
Display	6 digits, red 7 segment LED display; 8 mm [0.32"] high
Data backup	EEPROM
Operating temperature	10 ... 26 V DC -20°C ... +65°C [-4°F ... +149°F] > 26 ... 30 V DC -20°C ... +55°C [-4°F ... +131°F] (non-condensing)
Storage temperature	-25°C ... +70°C [-13°F ... +158°F]

Electrical characteristics	
Power supply	10 ... 30 V DC, with integrated reverse polarity protection
Current consumption	max. 40 mA
EMC standards	EN 55011 class B, EN 61000-6-2, EN 61000-6-3 EN 61326-1
UL approval	file E128604

Mechanical characteristics	
Housing	front panel mount 48x24 mm [1.89 x 0.94"] acc. to DIN 43700; RAL 7021, dark grey
Protection	IP65 (front side)
Weight	approx. 50 g [1.76 oz]
Vibration resistance acc. to EN 60068-2-6	10 ... 55 Hz / 1 mm [0.04"] / 30 min
Shock resistance acc. to EN 60068-2-27	100 G: 2 ms 10 G: 6 ms

Inputs	
Polarity of inputs	programmable, NPN or PN
Input resistance	approx. 5 kΩ
Counting frequency ¹⁾	max. 60 kHz, can be damped to 30 Hz
Display range	timer 0.001 s ... 999999 h frequency meter 1/min or 1/sec
Minimum pulse duration of the reset input	5 ms
Input switching level (HTL)	LOW 0 ... 0.2 x U _B [V DC] HIGH 0.6 x U _B ... 30 V DC
Input switching level at 4 ... 30 V DC	LOW 0 ... 2 V DC HIGH 4 ... 30 V DC
Accuracy	< 0.1 % frequency meter, tachometer

1) Details see manual

Multifunction devices, electronic

LED dual function displays **Universal with dual functions, 4 combinations (DC)** **Codix 52U**

Applications for dual functions

- Pulse and frequency (speed)
e.g. production data acquisition: total piece count and speed on OEM equipment, flow rate measuring systems – total flow and current flow
- 2 pulse counters
Measurement of batch and total piece count or of daily production count and total count values
- Pulse and time (maintenance counter)
Used in the lift industry as trip counters and hours-run meters and on production machines for piece and time counting, flow and time measurement, materials handling time and quantities
- 2 timers
Measurement of total time and orderspecific times, maintenance intervals and total time, time of day and total time

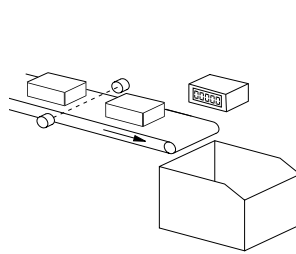

Piece count on conveyor and production speed

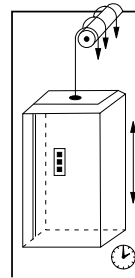

Trip counter and hours-run

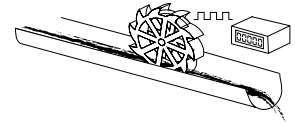

Flow rate and total volume

Block diagram

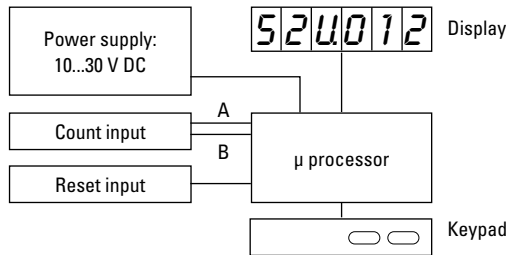

Terminal assignment

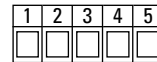

PIN	DC version
1	10 ... 30 V DC
2	0 V GND
3	INP A
4	INP B
5	Reset

Function of the inputs INP A, INP B

Counter with 2 totalizing ranges:

INP A: Dynamic count input counter 1 and counter 2
INP B: Inactive

Totalizer and timer:

INP A: Dynamic count input for totalizer
INP B: Start/Stop or gate input for timer

Totalizer and frequency meter:

INP A: Dynamic count input/frequency input
INP B: Inactive

Timer with 2 time ranges:

INP A: Start input (depends on input type)
INP B: Start/Stop or gate input for timer (depends on input type)

Product overview
Basics

Pulse counters

Preset counters

Hour meters
Timers

Frequency displays
Tachometers

Position displays

Multifunction devices

Energy meters

Process devices

Temperature devices

Strain-gauge controllers

Accessories
Index

Multifunction devices, electronic

LED dual function displays	Universal with dual functions, 4 combinations (DC)	Codix 52U
-----------------------------------	---	------------------

Dimensions

Dimensions in mm [inch]

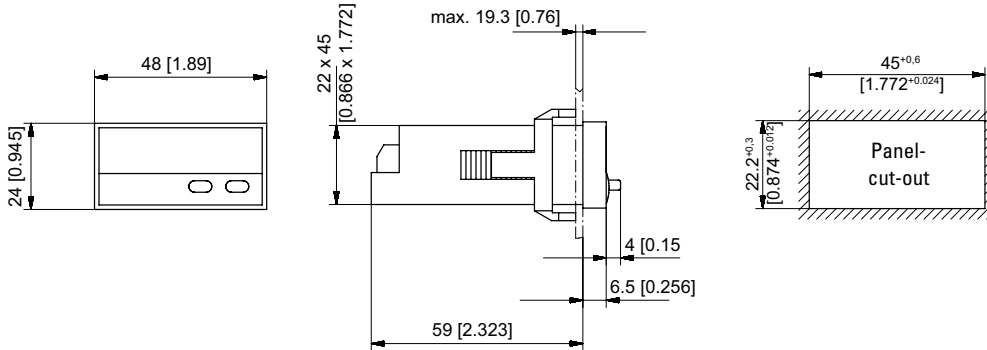

Front bezel for clip mounting (included in delivery)

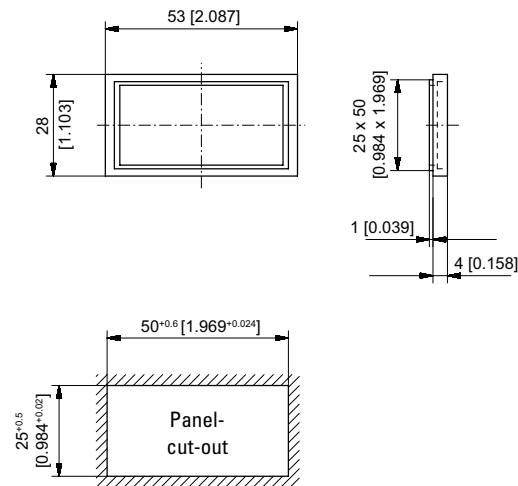

Front bezel for screw mounting (included in delivery)

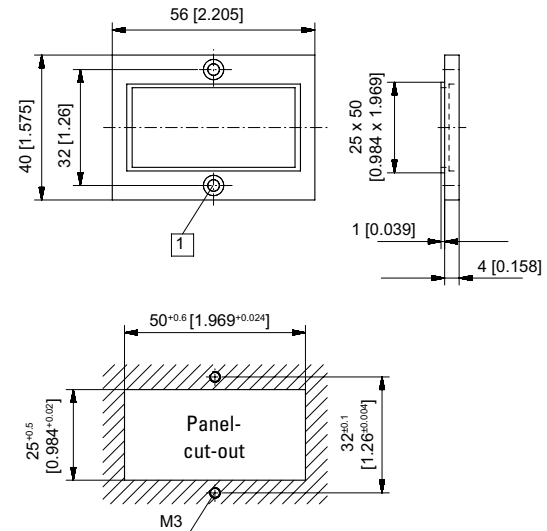

1 Countersinking A13, DIN 74

Product overview Basics
Pulse counters
Preset counters
Hour meters Timers
Frequency displays Tachometers
Position displays
Multifunction devices
Energy meters
Process devices
Temperature devices
Strain-gauge controllers
Accessories Index

LED dual function displays

6 count modes with tachometer (DC)

Codix 52P



The Codix 52P is a voltage-powered pulse counter/ position display with 4 different count input modes and separate tachometer.

With separate inputs, for fast and slow count pulses, with 6-digit LED display for NPN, PNP input signals.



DC 10 ... 30V Power supply	000000 DIN 48 x 24 DIN front bezel	-20...+65°C Temperature range	IP65 High protection level	PROG Menu-driven programming	max. 30 kHz Pulse counter/ Totalizer	1/sec 1/min Frequency meter/ tachometer	POSITION Position display	t Hz HRA Frequency meter HRA
---	---	---	--------------------------------------	--	---	---	-------------------------------------	---

Powerful

- Fast count and frequency input – input frequency max. 30 kHz (can be damped to 30 Hz for mechanical contacts).
- Robust housing – IP65 protected.
- Very bright LED display, 8 mm high, 6 digits.
- Very accurate precise frequency measurement principle (HRA-High Rate Accuracy System)
Frequencies up to 38 Hz are calculated using time-interval (period duration) measurement. Frequencies > 38 Hz are calculated using a special time base (gate time) measurement. A very high accuracy of < 0.1 % is achieved, even with very short gate times. The resulting measurement is available after a max. of 50 ms.
- Short start-up time – detects input pulses just 16 msec after being switched on => no pulses are lost with a simultaneous motor start-up.

User-friendly and universal

- Large keys – can also be operated when wearing gloves.
- Programming:
 - Simple uniform menu-driven programming and operation.
 - Possible to enter the programming also during operation with a confirmation prompt.
 - Pressing the right key switches between displays.
- Individually programmable scaling: multiplication and division factor (0.0001...99.9999), to display corresponding engineering units, e.g. position in 1/10 mm and speed in RPM.
- Separate factors for frequency- and pulse counting.
- 4 different count input modes for the position display: 2-channel input for detecting count direction, difference or adding mode, quadrature x1, x2 or x4. 1 separate input for rotary speed and speed, display in 1/min or 1/sec.
- Inputs: as an alternative to the HTL inputs, devices are available with a 4 ... 30 V DC input level, for use as parallel dislplays to PLCs.

Order code

6.52P . 01 2 . 3 X 0

- a** Input switching level
0 = Standard (HTL)
A = 4 ... 30 V DC

Delivery specification

- Counter
- Mounting clip
- Front bezel for screw mounting (T008181) 56 x 40 mm [2.20 x 1.57"], panel cut-out 50 x 25 mm [1.97 x 0.98"]
- Front bezel for clip mounting (T008180) 53 x 28 mm [2.09 x 1.10"], panel cut-out 50 x 25 mm [1.97 x 0.98"]
- Gasket
- Instruction manual, multilingual

Product overview
Basics

Pulse counters

Preset counters

Hour meters
Timers

Frequency displays
Tachometers

Position displays

Multifunction
devices

Energy meters

Process devices

Temperature
devices

Strain-gauge
controllers

Accessories
Index

Multifunction devices, electronic

LED dual function displays 6 count modes with tachometer (DC) Codix 52P

Accessories	Dimensions in mm [inch]	Order no.
Adapter front bezel, 72 x 36 [2.83 x 1.42]	for cut-out 68 x 33 [2.68 x 1.30] to cut-out 45 x 22.2 [1.77 x 0.87], for counters 48 x 24 [1.89 x 0.94], as set	black and silver anodised 162704 Set
Adapter front bezel, 48 x 48 [1.89 x 1.89]	for cut-out 45 x 45 [1.77 x 1.77] to cut-out 45 x 22.2 [1.77 x 0.87], with clip mounting for counters 48 x 24 [1.89 x 0.94]	black T008883
Adapter front bezel, 60 x 50 [2.36 x 1.97]	for cut-out 54 x 29 [2.13 x 1.14] to cut-out 45 x 22.2 [1.77 x 0.87], with screw mounting and gasket for counters 48 x 24 [1.89 x 0.94]	black N003001
Transparent cover, lockable, IP65	for cut-out 54 x 29 [2.13 x 1.14], for screw mounting to front bezel F1B or adapter front bezel N003001, for counters with cut-out 50 x 25 [1.97 x 0.98] or 45 x 22.2 [1.77 x 0.87]	N003002
Sealing cover type K1, IP65	suitable for front bezel 60 x 50 [2.36 x 1.97], for screw mounting of electromech. counters and via adapter front bezel N003001 for counters 48 x 24 [1.89 x 0.94]	G008301
Mounting frame with cut-out 50 x 25 [2.36 x 1.97] via separate adapter also for 45 x 22.2 [1.77 x 0.87]	for snap-on mounting on 35 [1.38] top-hat DIN rail, for counters 53 x 28 [2.09 x 1.10] and via separate adapter (T008180) for counters 48 x 24 [1.89 x 0.94]	chromated G300004

Suitable gaskets, other accessories and installation examples for optional accessories can be found in chapter accessories or in the accessories section under: www.kuebler.com/accessories.

Technical data

General technical data	
Display	6 digits, red 7 segment LED display; 8 mm [0.32"] high
Data backup	EEPROM
Operating temperature	10 ... 26 V DC -20°C ... +65°C [-4°F ... +149°F] > 26 ... 30 V DC -20°C ... +55°C [-4°F ... +131°F] (non-condensing)
Storage temperature	-25°C ... +70°C [-13°F ... +158°F]

Electrical characteristics	
Power supply	10 ... 30 VDC, with integrated reverse polarity protection
Current consumption	max. 40 mA
EMC standards	EN 55011 class B, EN 61000-6-2, EN 61000-6-3 EN 61326-1
UL approval	file E128604

Mechanical characteristics	
Housing	front panel mount 48 x 24 mm [1.89 x 0.94"] acc. to DIN 43700; RAL 7021, dark grey
Protection	IP65 (front side)
Weight	approx. 50 g [1.76 oz]
Vibration resistance acc. to EN 60068-2-6	10 ... 55 Hz / 1 mm [0.04"] / 30 min
Shock resistance acc. to EN 60068-2-27	100 G: 2 ms 10 G: 6 ms

Inputs	
Polarity of inputs	programmable, NPN or PNP for all inputs
Input resistance	approx. 5 kΩ
Counting frequency ¹⁾	max. 30 kHz, can be damped to 30 Hz
Display range	tachometer 1/min or 1/sec
Minimum pulse duration of the reset input	5 ms
Input switching level (HTL)	LOW 0 ... 0.2 x U _B [V DC] HIGH 0.6 x U _B ... 30 V DC
Input switching level at 4 ... 30 V DC	LOW 0 ... 2 V DC HIGH 4 ... 30 V DC
Accuracy	< 0.1 % frequency meter, tachometer

1) Details see manual

Multifunction devices, electronic

LED dual function displays

6 count modes with tachometer (DC)

Codix 52P

Applications for frequency and position display / totalizer

Position and rotary speed applications, e.g.

- OEM equipment or retrofitting to drilling machines
- OEM equipment on flow measuring plant, e.g. total flow and current flow
- Total piece count and pieces per minute, where the pulse counting occurs in the add/subtract mode, in order to deduct reject parts
- Production data acquisition: total piece count and production speed, or absolute distance traversed and current speed

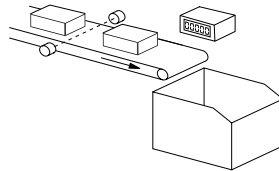

Piece count on conveyor and production speed

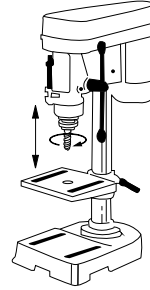

Rotary speed and drilling depth

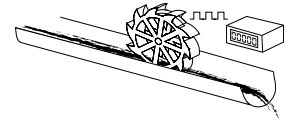

Flow rate and total volume

Block diagram

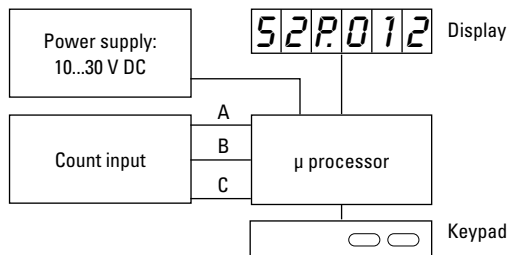

Terminal assignment

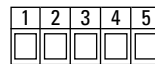

PIN	DC version
1	10 ... 30 V DC
2	0 V GND
3	INP A (count)
4	INP B (count)
5	INP C (frequency)

Function of the inputs INP A, INP B, INP C

INP A and INP B:

Two channel pulse input with 6 different count modes

INP C:

Frequency input, single channel

Product overview
Basics

Pulse counters

Preset counters

Hour meters
Timers

Frequency displays
Tachometers

Position displays

Multifunction
devices

Energy meters

Process devices

Temperature
devices

Strain-gauge
controllers

Accessories
Index

Multifunction devices, electronic

LED dual function displays 6 count modes with tachometer (DC) Codix 52P

Dimensions

Dimensions in mm [inch]

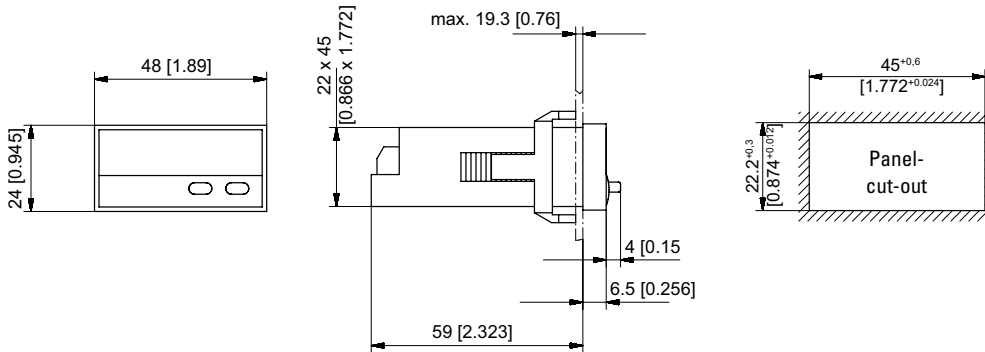

Front bezel for clip mounting (included in delivery)

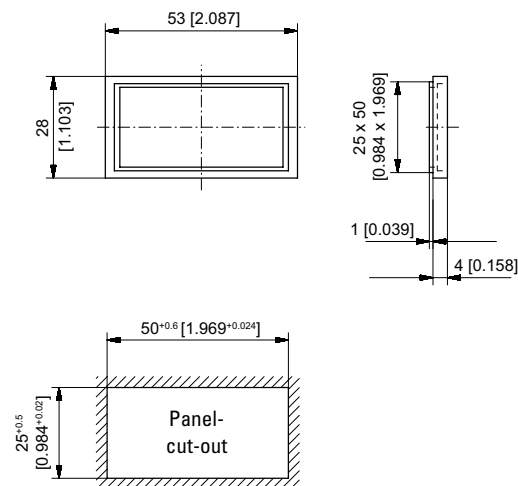

Front bezel for screw mounting (included in delivery)

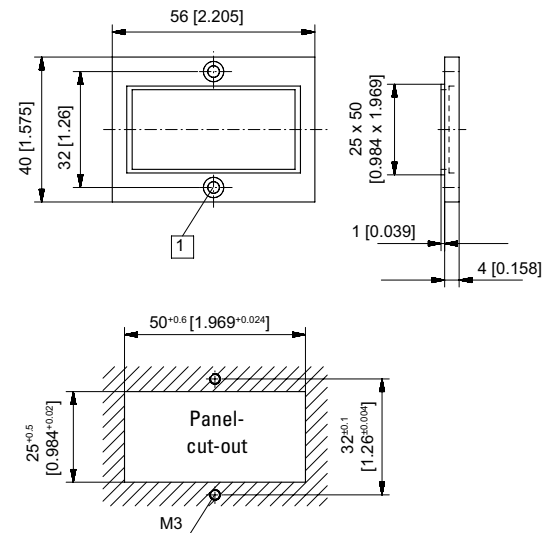

1 Countersinking A13, DIN 74

- Product overview Basics
- Pulse counters
- Preset counters
- Hour meters Timers
- Frequency displays Tachometers
- Position displays
- Multifunction devices
- Energy meters
- Process devices
- Temperature devices
- Strain-gauge controllers
- Accessories Index

LED dual function displays

Universal with dual functions, 4 combinations (AC+DC)

Codix 54U



The Codix 54U is a voltage-powered dual function counter with 4 functions in one device:

Counter with 2 totalizing ranges, totalizer and timer, totalizer and frequency meter, timer with 2 time ranges.

For fast and slow count pulses, with 6-digit LED display for NPN, PNP input signals.

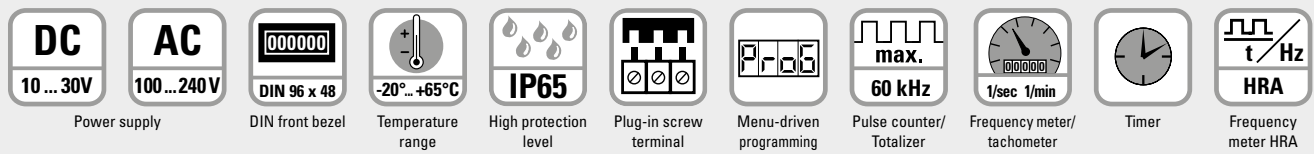

Powerful

- Fast count and frequency input – input frequency max. 60 kHz (can be damped to 30 Hz for mechanical contacts).
- Robust housing – IP65 protected.
- Very bright LED display, 14 mm high, 6 digits.
- Very accurate precise frequency measurement principle (HRA-High Rate Accuracy System)
Frequencies up to 38 Hz are calculated using time-interval (period duration) measurement. Frequencies > 38 Hz are calculated using a special time base (gate time) measurement. A very high accuracy of < 0.1 % is achieved, even with very short gate times. The resulting measurement is available after a max. of 50 ms.
- Short start-up time – detects input pulses just 16 msec after being switched on => no pulses are lost with a simultaneous motor start-up.

User-friendly and universal

- Large keys – can also be operated when wearing gloves.
- Programming:
 - Simple uniform menu-driven programming and operation.
 - Possible to enter the programming also during operation with a confirmation prompt.
 - Pressing the right key switches between displays.
- Individually programmable scaling: multiplication and division factor (0.0001...99.9999), to display corresponding engineering units, e.g. position in 1/10 mm and speed in RPM.
- Separate factors for frequency- and pulse counting.
- AC or DC power supply.
- Inputs: as an alternative to the HTL inputs, devices with a 5 V DC input level are available, for use as parallel displays for PLCs.
- Timer specials: timer or hours-run meter with various Start/Stop measurements, time range settings in hours, minutes or seconds, with decimal point. Resolutions up to 1/1000 can be programmed.

Order code

6.54U . 01 2 . XX0
a b

a Power supply
 0 = 100 ... 240 V AC, ±10 %
 3 = 10 ... 30 V DC

b Input switching level
 0 = Standard (HTL)
 A = 4 ... 30 V DC

Delivery specification

- Digital display
- Mounting clip
- Gasket
- 2 plug-in screw terminals
- Instruction manual, multilingual

Replacement parts

7 pin screw terminal RM 3.81 1 ... 7: N100387
 2 pin screw terminal RM 5.08 1 ... 2: N100133

Multifunction devices, electronic

LED dual function displays	Universal with dual functions, 4 combinations (AC+DC)	Codix 54U
Accessories	Dimensions in mm [inch]	Order no.
Mounting frame with cut-out 92 x 45 [3.62 x 1.77]	for snap-on mounting on 35 [1.38] top-hat DIN rail, for counters 96 x 48 [3.74 x 1.89]	grey G300005

Suitable gaskets as well as further accessories can be found in the accessories section or in the accessories area of our website at: www.kuebler.com/accessories.

Technical data

General technical data	
Display	6 digit, red 7 segment LED display; 14 mm [0.55"] high
Data backup	EEPROM
Operating temperature	10 ... 26 V DC -20°C ... +65°C [-4°F ... +149°F] (non-condensing)
Storage temperature	-25°C ... +70°C [-13°F ... +158°F]
Altitude	up to 2000 m [6562']

Electrical characteristics	
Power supply	10 ... 30 V DC, with reverse polarity protection 100 ... 240 V AC, ±10 %
Current consumption	max. 50 mA, 6 VA
EMC standards	EN 55011 class B, EN 61000-6-2, EN 61000-6-3
Device safety	designed to protection class 2 application area pollution level 2
UL approval	file E128604

Mechanical characteristics	
Housing	front panel mount 96 x 48 mm [3.74 x 1.89"] acc. to DIN 43700; RAL 7021, dark grey
Protection	IP65 (front side)
Weight	approx. 150 g [5.29 oz]

Inputs	
Polarity of inputs	programmable, NPN or PNP for all inputs
Input resistance	approx. 5 kΩ
Counting frequency ¹⁾	max. 60 kHz, can be damped to 30 Hz
Display range	timer 0.001 s ... 999999 h frequency meter 1/min or 1/sec
Minimum pulse duration of the reset input	5 ms
Input switching level standard version (HTL)	
DC power supply	LOW 0 ... 0.2 x U _B [V DC] HIGH 0.6 x U _B ... 30 V DC
AC power supply	LOW 0 ... 4 V DC HIGH 12 ... 30 V DC
Input switching level at 4 ... 30 V DC	
	LOW 0 ... 2 V DC HIGH 4 ... 30 V DC
Accuracy	
frequency meter / tachometer	< 0.1 %
timer	< 50 ppm

Outputs	
Sensor power supply (AC version)	24 V DC ±15 %/100 mA

Applications for dual functions

- Pulse and frequency (speed)
e.g. production data acquisition: total piece count and speed on OEM equipment, flow rate measuring systems – total flow and current flow
- 2 pulse counters
Measurement of batch and total piece count or of daily production count and total count values
- Pulse and time (maintenance counter)
Used in the lift industry as trip counters and hours-run meters and on production machines for piece and time counting, flow and time measurement, materials handling time and quantities
- 2 timers
Measurement of total time and orderspecific times, maintenance intervals and total time, time of day and total time

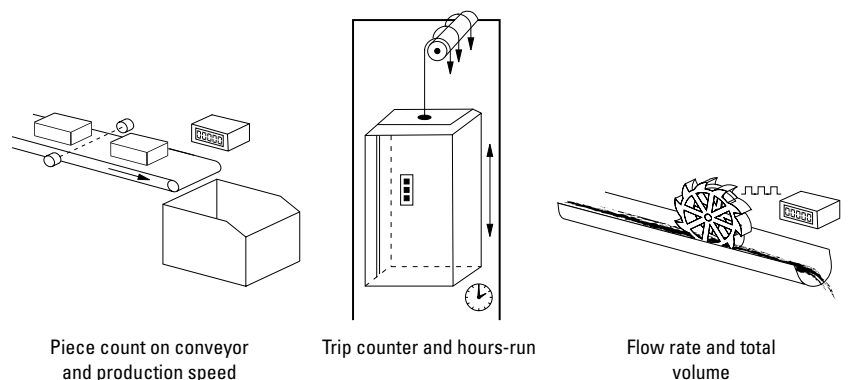

Piece count on conveyor and production speed

Trip counter and hours-run

Flow rate and total volume

1) Details see manual

Multifunction devices, electronic

LED dual function displays

Universal with dual functions, 4 combinations (AC+DC)

Codix 54U

Block diagram

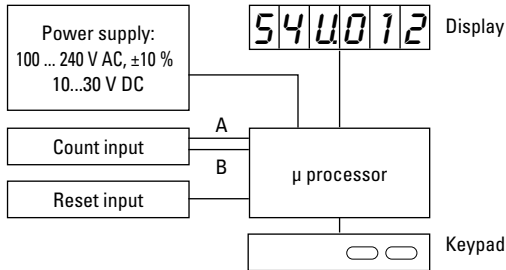

Terminal assignment

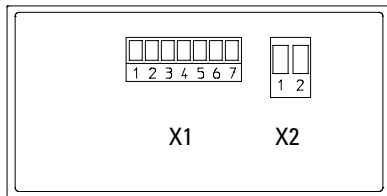

Connection X1

PIN	AC version	DC version
1	n.c.	
2	n.c.	
3	Reset	
4	INP B	
5	INP A	
6	GND out	n.c.
7	+24 V out	n.c.

Connection X2

PIN	AC version	DC version
1	100 ... 240 V AC, ±10 %	0 V DC (GND)
2	100 ... 240 V AC, ±10 %	10 ... 30 V DC

Function of the inputs INP A, INP B

Counter with 2 totalizing ranges:

INP A: Dynamic count input counter 1 and counter 2
INP B: Inactive

Totalizer and timer:

INP A: Dynamic count input for totalizer
INP B: Start/Stop or gate input for timer

Totalizer and frequency meter:

INP A: Dynamic count input/frequency input
INP B: Inactive

Timer with 2 time ranges:

INP A: Start input (depends on input type)
INP B: Start/Stop or gate input for timer (depends on input type)

Dimensions

Dimensions in mm [inch]

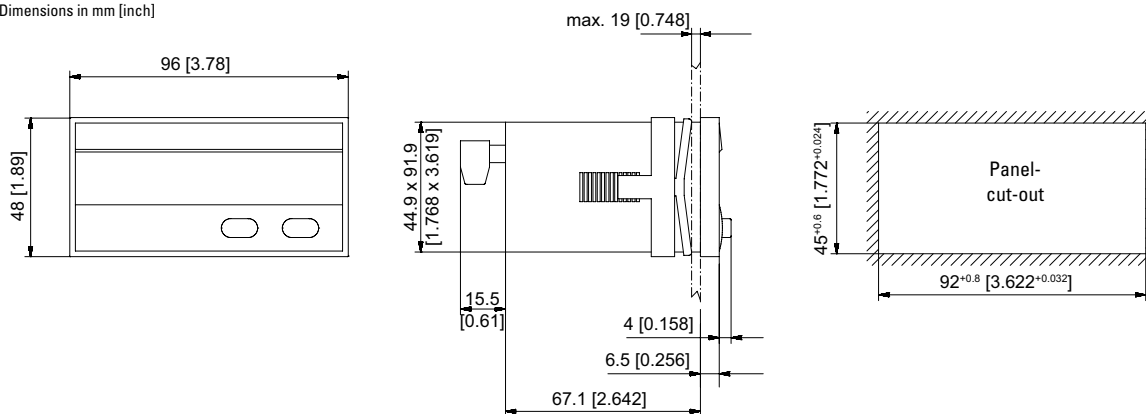

LED dual function displays **6 count modes with tachometer (AC+DC)** **Codix 54P**



The Codix 54P is a voltage-powered pulse counter/ position display with 4 different count input modes and separate tachometer.

With separate inputs, for fast and slow count pulses, with 6-digit LED display for NPN, PNP input signals.



DC 10 ... 30V Power supply	AC 100 ... 240V DIN front bezel	000000 DIN 96 x 48	-20°...+65°C Temperature range	IP65 High protection level	Plug-in screw terminal	max. 30 kHz Pulse counter/ Totalizer	1/sec 1/min Frequency meter/ tachometer	POSITION Position display	HRA Frequency meter HRA
---	--	------------------------------	--	--------------------------------------	-------------------------------	--	---	-------------------------------------	-----------------------------------

Powerful

- Fast count and frequency input – input frequency max. 30 kHz (can be damped to 30 Hz for mechanical contacts).
- Robust housing – IP65 protected.
- Very bright LED display, 14 mm high, 6 digits.
- Very accurate precise frequency measurement principle (HRA-High Rate Accuracy System)
Frequencies up to 38 Hz are calculated using time-interval (period duration) measurement. Frequencies > 38 Hz are calculated using a special time base (gate time) measurement. A very high accuracy of < 0.1 % is achieved, even with very short gate times. The resulting measurement is available after a max. of 50 ms.
- Short start-up time – detects input pulses just 16 msec after being switched on => no pulses are lost with a simultaneous motor start-up.

User-friendly and universal

- Large keys – can also be operated when wearing gloves.
- Programming:
 - Simple uniform menu-driven programming and operation .
 - Possible to enter the programming also during operation with a confirmation prompt.
 - Pressing the right key switches between displays.
- Individually programmable scaling: multiplication and division factor (0.0001...99.9999), to display corresponding engineering units, e.g. position in 1/10 mm and speed in RPM.
- Separate factors for frequency and pulse counting.
- 4 different count input modes for the position display: 2-channel input for detecting count direction, difference or adding mode, quadrature x1, x2 or x4. 1 separate input for rotary speed and speed, display in 1/min or 1/sec.
- AC or DC supply with sensor power supply.
- Inputs: as an alternative to the HTL inputs, devices with a 5 V DC input level are available, for use as parallel displays for PLCs.

Order code

6.54P . 012 . XX0
a b

a Power supply
0 = 100 ... 240 V AC, ±10 %
3 = 10 ... 30 V DC

b Input switching level
0 = Standard (HTL)
A = 4 ... 30 V DC

Delivery specification
 · Digital display
 · Mounting clip
 · Gasket
 · 2 plug-in screw terminals
 · Instruction manual, multilingual

Replacement parts
 7 pin screw terminal RM 3.81 1 ... 7: N100387
 2 pin screw terminal RM 5.08 1 ... 2: N100133

Multifunction devices, electronic

LED dual function displays	6 count modes with tachometer (AC+DC)	Codix 54P
Accessories	Dimensions in mm [inch]	Order no.
Mounting frame with cut-out 92 x 45 [3.62 x 1.77]	for snap-on mounting on 35 [1.38] top-hat DIN rail, for counters 96 x 48 [3.74 x 1.89]	grey G300005

Suitable gaskets as well as further accessories can be found in the accessories section or in the accessories area of our website at: www.kuebler.com/accessories.

Technical data

General technical data	
Display	6 digit, red 7 segment LED display; 14 mm [0.55"] high
Data backup	EEPROM
Operating temperature	-20°C ... +65°C [-4°F ... +149°F] (non-condensing)
Storage temperature	-25°C ... +70°C [-13°F ... +158°F]
Altitude	up to 2000 m [6562']

Electrical characteristics	
Power supply	10 ... 30 VDC, with reverse polarity protection 100 ... 240 V AC, ±10 %
Current consumption	max. 50 mA, 6 VA
EMC standards	EN 55011 class B, EN 61000-6-2, EN 61000-6-3
Device safety	designed to protection class 2 application area pollution level 2
UL approval	file E128604

Mechanical characteristics	
Housing	front panel mount 96 x 48 mm [3.74 x 1.89"] acc. to DIN 43700; RAL 7021, dark grey
Protection	IP65 (front side)
Weight	approx. 150 g [5.29 oz]

Inputs	
Polarity of inputs	programmable, NPN or PNP for all inputs
Input resistance	approx. 5 kΩ
Counting frequency ¹⁾	max. 30 kHz, can be damped to 30 Hz
Display range	tachometer 1/min or 1/sec
Minimum pulse duration of the reset input	5 ms
Input switching level standard version (HTL)	
DC power supply	LOW 0 ... 0.2 x U _B [V DC] HIGH 0.6 x U _B ... 30 V DC
AC power supply	LOW 0 ... 4 V DC HIGH 12 ... 30 V DC
Input switching level at 4 ... 30 V DC	
	LOW 0 ... 2 V DC HIGH 4 ... 30 V DC
Accuracy	frequency meter/tachometer < 0.1 %

Outputs	
Sensor power supply (AC version)	24 V DC ±15 %/100 mA

Applications for frequency and position display / totalizer

Position and rotary speed applications, e.g.

- OEM equipment or retrofitting to drilling machines
- OEM equipment on flow measuring plant, e.g. total flow and current flow
- Total piece count and pieces per minute, where the pulse counting occurs in the add/subtract mode, in order to deduct reject parts
- Production data acquisition: total piece count and production speed, or absolute distance traversed and current speed

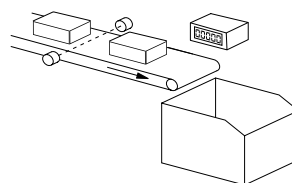

Piece count on conveyor and production speed

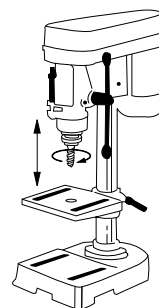

Rotary speed and drilling depth

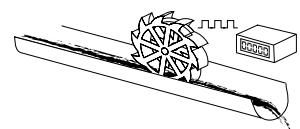

Flow rate and total volume

1) Details see manual

Multifunction devices, electronic

LED dual function displays 6 count modes with tachometer (AC+DC) Codix 54P

Block diagram

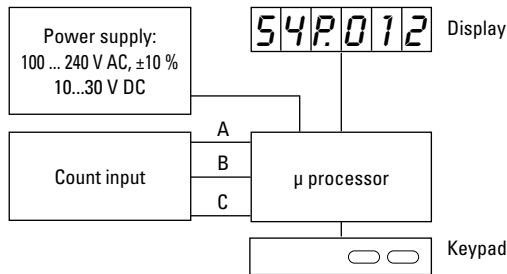

Terminal assignment

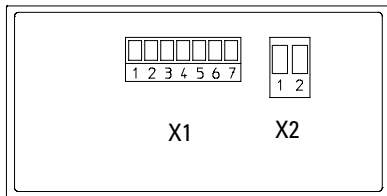

Connection X1

PIN	AC version	DC version
1	n.c.	
2	n.c.	
3	INP C (frequency)	
4	INP B (frequency)	
5	INP A (Count)	
6	GND out	n.c.
7	+24 V out	n.c.

Connection X2

PIN	AC version	DC version
1	100 ... 240 V AC, ±10 %	0 V DC (GND)
2	100 ... 240 V AC, ±10 %	10 ... 30 V DC

Function of the inputs INP A, INP B, INP C

INP A and INP B:

Two channel pulse input with 6 different count modes

INP C:

Frequency input, single channel

Dimensions

Dimensions in mm [inch]

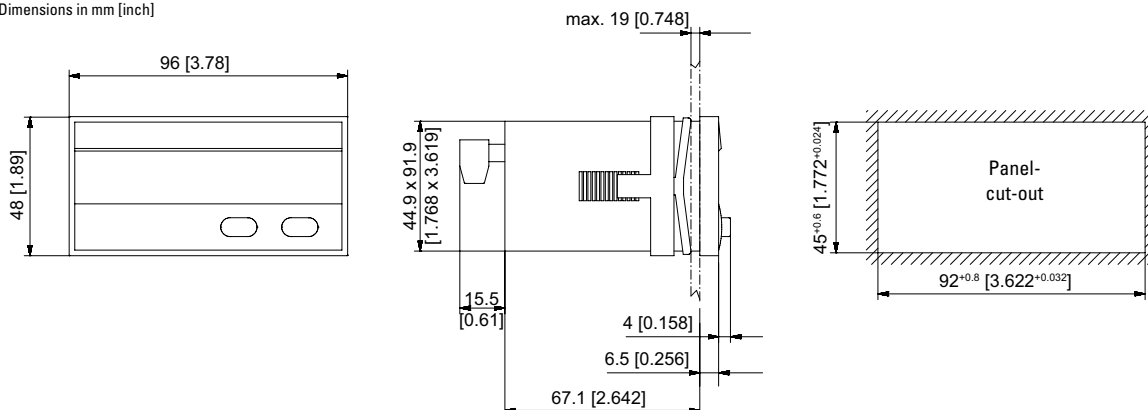

Product overview
Basics
Pulse counters
Preset counters
Hour meters
Timers
Frequency displays
Tachometers
Position displays
Multifunction devices
Energy meters
Process devices
Temperature devices
Strain-gauge controllers
Accessories
Index

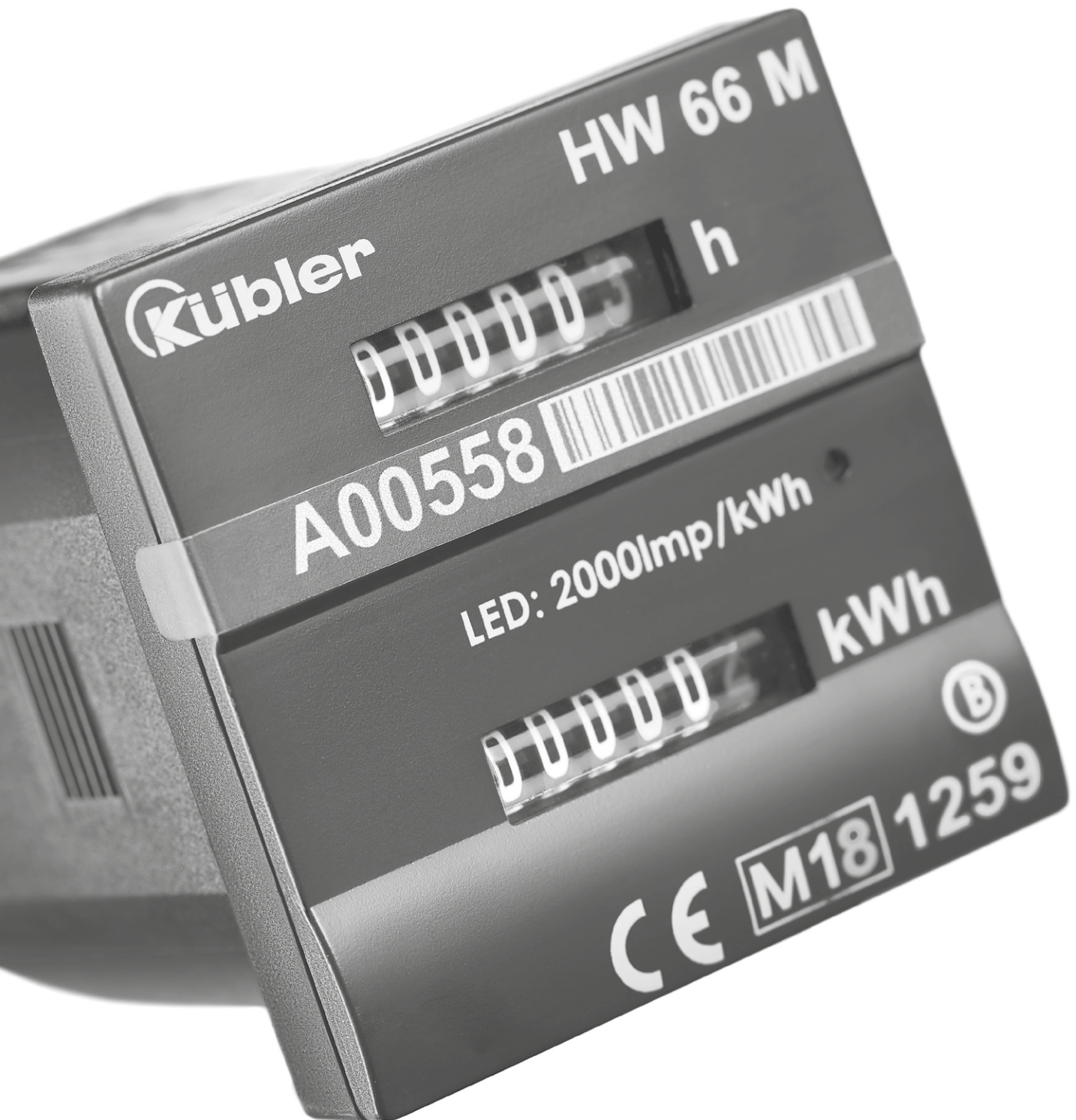

Product overview
Basics

Pulse counters

Preset counters

Hour meters
Timers

Frequency displays
Tachometers

Position displays

Multifunction
devices

Energy meters

Process devices

Temperature
devices

Strain-gauge
controllers

Accessories
Index

Energy meters

Energy meters		Type	Page
Dual function counters	Energy and time (AC)	HW 66 / HW 66 M	266

Product overview
Basics

Pulse counters

Preset counters

Hour meters
Timers

Frequency displays
Tachometers

Position displays

Multifunction
devices

Energy
meters

Process devic

Temperature
devices

Strain-gauge
controllers

Accessories
Index

Dual function counters **Energy and time (AC)** **HW 66 / HW 66 M**



MID approved



The HW 66 and HW 66 M combination meters consist of an hour meter and an energy meter.

These panel-mounted devices require only a limited installation depth and can be used in a wide variety of application areas. The count pulses can be read out via the SO output.

Additional model:
HW 66 M – MID version for applications requiring official calibration.



AC 115/230V Power supply	-20° + 55° Temperature range	DIN 48 x 48 DIN front bezel	IP65 High protection level	12345 No reset	2 x 6 Display 2 x 6 digit	kWh Energy meter	Timer
---------------------------------------	--	---------------------------------------	--------------------------------------	--------------------------	-------------------------------------	----------------------------	--------------

Product features

- Metering of hours run and energy consumption in one compact device – panel mounting.
- Wide temperature range.
- Remote readout via SO outputs on request.
- Shows both values in parallel.
- Easy-to-read display – can also be read if no voltage present.

Benefits

- Tamper-proof fixed installation with high degree of protection.
- High measuring accuracy.
- Can be officially calibrated (MID).

Applications

Dehumidifiers, hire equipment and machinery, air-conditioning, production equipment, current generators.

Order specifications

Type	Voltage	Order no.	Delivery includes	Only for MID version:
HW 66	230 V AC	3.563.201.075 ¹⁾	• Counter • Flat gasket • Mounting clip • Instruction manual	• Type plate
HW 66	115 V AC	3.563.201.074 ¹⁾		
MID version: HW 66 M	230 V AC	3.56M.201.075 ¹⁾		If the type plate on the side of the HW 66 M is no longer legible after the installation, the provided additional type plate can be affixed on the front panel of the device in order to comply if necessary with the legal requirements relating to calibration.

Accessories	Dimensions in mm [inch]	Order no.
Adapter front bezel, 55 x 55 [2.17 x 2.17]	for cut-out 50 x 50 [1.97 x 1.97] to ø 50.5 [1.99], with clip mounting for counters 48 x 48 [1.89 x 1.89]	black T008171
Adapter front bezel, 60 x 75 [2.36 x 2.95]	for cut-out 50 x 50 [1.97 x 1.97] to cut-out 45 x 45 [1.77 x 1.77] with screw mounting for counters 48 x 48 [1.89 x 1.89]	black T008860
Adapter front bezel, 72 x 72 [2.83 x 2.83]	for cut-out 68 x 68 [2.68 x 2.68] to cut-out 45 x 45 [1.77 x 1.77] Mating clip T009420 must be ordered separately	black T008177
Adapter front bezel, ø 72 [2.83]	for cut-out ø 60 [2.36] to cut-out 45 x 45 [1.77 x 1.77] with clip mounting for counters 48 x 48 [1.89 x 1.89]	black N510226
Adapter front bezel, 55 x 55 [2.17 x 2.17]	for cut-out 50 x 50 [1.97 x 1.97] to cut-out 45 x 45 [1.77 x 1.77] with clip mounting for counters 48 x 48 [1.89 x 1.89] Gasket 58 x 58 [2.28 x 2.28], for cut-out 50.2 x 50.2 [1.98 x 1.98]	black T008853 N511004
Mounting frame with cut-out 50 x 50 [2.36 x 2.36] via separate adapter also for 45 x 45 [1.77 x 1.77]	for snap-on mounting on 35 [1.38] top-hat DIN rail, for counters 48 x 48 [1.89 x 1.89], 53 x 53 [2.09 x 2.09] and 55 x 55 [2.17 x 2.17]	chromated G300003

Suitable gaskets as well as further accessories can be found in the accessories section or in the accessories area of our website at: www.kuebler.com/accessories.

1) Standard stock model

Energy meters

Dual function counters Energy and time (AC) HW 66 / HW 66 M

Technical data

General technical data	
Power supply	115/230 V AC, -20 % / +15 % 50 or 60 Hz
Digits	2 x 6 digit (single units digit red)
Height of figures (optical)	4 x 1.7 mm [0.16 x 0.067"]
Colour of figures	white and red on black
Operating temperature	HW 66 -20°C ... +55°C [-4°F ... +131°F] HW 66 M -10°C ... +55°C [+14°F ... +131°F] (non-condensing)
Storage temperature	-25°C ... +65°C [-13°F ... +149°F]
Housing	DIN panel-mount 48 x 48 mm [1.89 x 1.89"]
Depth	55 mm [2.17"]
EMC standards	EN 55011 classe B, EN 61000-6-2, EN 61000-6-3, EN 61326-3-2
Measuring instruments directive (MID)	EN 50470-1, EN 50470-3
Protection	IP65, EN 60529 (front side) IP20 (rear side)
Connections	screw terminal, touch-safe
Max. core cross-section	inputs/outputs 2.5 mm ² [AWG 13] S0 output 2.5 mm ² [AWG 13]
LED function	LED on when power supply is connected LED blinks when energy is being measured

Energy meter	
Display	99999.9 kWh
Accuracy	class B, acc. to MID (for 50 Hz version)
Current	I _B = 5 A, I _{max} = 16 A
Current limits	≥ 20 mA up to 16 A
Start current	≥ 20 mA
S0 output	1000 pulses/kWh, 5 ... 30 V DC, I _{max} = 20 mA
Pulse duration	50 ms

Hour meter	
Display	99999.9 h (0.1 h = 6 min)
Accuracy	± 2 %
S0 output	10 imp/h, 5 ... 30 V DC, I _{max} = 20 mA
Pulse duration	50 ms
Start (Operating time)	with voltage applied to L _{in}

This hour meter shall not be used for electricity consumption calculation.

Applications

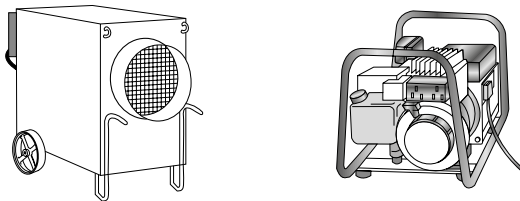

Retro- or standard fitting in dehumidifiers, current generators, air-conditioning, production equipment etc. for the accurate, traceable billing of operating and energy costs – especially also for hire equipment.

Dimensions

Dimensions in mm

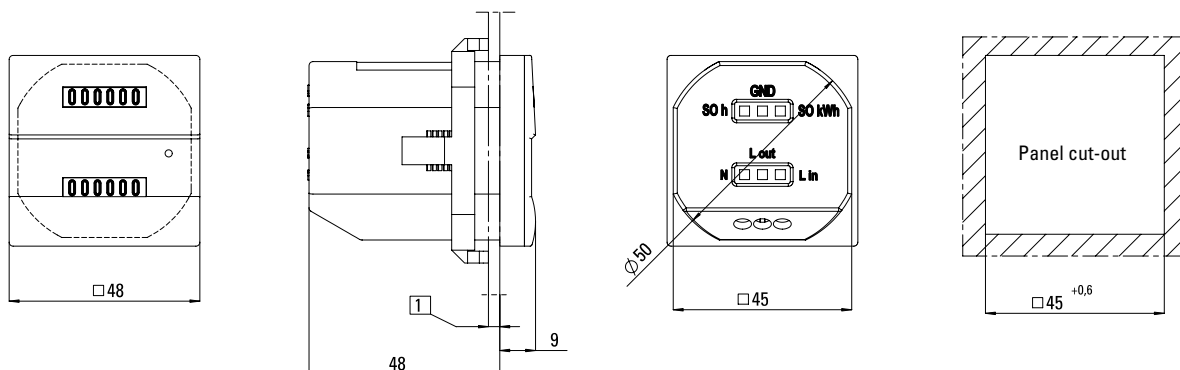

1 max. 6.5

Terminal assignment

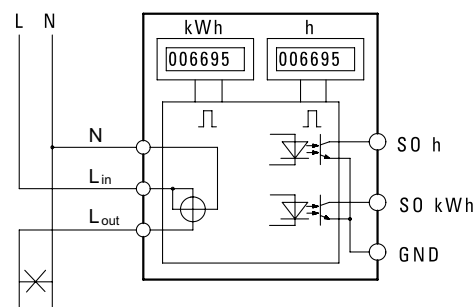



Product overview
Basics

Pulse counters

Preset counters

Hour meters
Timers

Frequency displays
Tachometers

Position displays

Multifunction
devices

Energy meters



Process devices

Temperature
devices

Strain-gauge
controllers

Accessories
Index

Process displays / Process controllers / Setpoint adjuster

Process displays		Type	Page
LED process displays	 Standard signals with Min / Max value detection, totalizer function (DC)	Codix 534	270
	Standard signals with Min / Max value detection, totalizer function (AC+DC)	Codix 565	273
Process controllers		Type	Page
LED process controllers	Standard signals with 2 limit values, analog output (AC+DC)	Codix 565	273
LCD touch process controllers	 2 standard signal inputs + 2 limit values or analog output (AC+DC)	573T	277
Setpoint adjuster		Type	Page
LED setpoint adjuster	Standard signal output for mA or V, also time-controlled (DC)	Codix 533	281

Product overview
Basics

Pulse counters

Preset counters

Hour meters
Timers

Frequency displays
Tachometers

Position displays

Multifunction
devices

Energy meters

Process devices

Temperature
devices

Strain-gauge
controllers

Accessories
Index

Process displays

LED process displays **Standard signals with Min / Max value detection, totalizer** **Codix 534**



Cost-effective standard signal display for front panel mount with scalable bright 5-digit LED display.

The 14 bit resolution ensures an accurate measuring value display range with minimum and maximum value detection and scalable totalizer for time-controlled summation of the measured value.



DC 10 ... 30 V Power supply	 mA, V Display scaling	 14 bit Resolution	 Menu-driven programming	 Galvanic isolation	 -20°... +60°C Temperature range	 IP65 High protection level	 min / max Min / Max value detection	 DIN 48 x 24 DIN front bezel	 5 LED LED display	 Totalizer function
--	------------------------------	--------------------------	-----------------------------	------------------------	--	-----------------------------------	--	------------------------------------	--------------------------	------------------------

Product features

- Input range: 1 current measuring input, 1 voltage measuring input.
- Compact display for standard signals.
- Display range -19 999 ... 99 999 with leading zeros suppression and programmable decimal point.
- Modern industrial design.
- Fast measuring time of max. 0.1 second.

Benefits

- Galvanic isolation with protection against incorrect polarity.
- Autom. Min / Max value detection.
- Totalizer with programmable factor, divisor and decimal point.
- Freely programmable characteristic curve end points to adapt the desired display value.
- Input for display hold or reset input for Min / Max value and totalizer.

Order no.

Display for analog signals with Min / Max value detection and totalizer

6.534.012.300 ¹⁾

Delivery specification

- Digital display
- Mounting clip
- Gasket
- Front bezel for screw mounting (T008181) 56 x 40 mm [2.20 x 1.57"], panel cut-out 50 x 25 mm [1.97 x 0.98"]
- Front bezel for clip mounting (T008180) 53 x 28 mm [2.09 x 1.10"], panel cut-out 50 x 25 mm [1.97 x 0.98"]
- 1 set of self-adhesive symbols
- Instruction manual, multilingual

1) Stock types.

Product overview Basics
Pulse counters
Preset counters
Hour meters Timers
Frequency displays Tachometers
Position displays
Multifunction devices
Energy meters
Process devices
Temperature devices
Strain-gauge controllers
Accessories Index

Process displays

LED process displays Standard signals with Min/Max value detection, totalizer Codix 534

Accessories	Dimensions in mm [inch]	Order no.
Adapter front bezel, 72 x 36 [2.83 x 1.42]	for cut-out 68 x 33 [2.68 x 1.30] to cut-out 45 x 22.2 [1.77 x 0.87], for counters 48 x 24 [1.89 x 0.94], as set black and silver anodized	162704 Set
Adapter front bezel, 48 x 48 [1.89 x 1.89]	for cut-out 45 x 45 [1.77 x 1.77] to cut-out 45 x 22.2 [1.77 x 0.87], with clip mounting for counters 48 x 24 [1.89 x 0.94] black	T008883
Adapter front bezel, 60 x 50 [2.36 x 1.97]	for cut-out 54 x 29 [2.13 x 1.14] to cut-out 45 x 22.2 [1.77 x 0.87], with screw mounting and gasket for counters 48 x 24 [1.89 x 0.94] black	N003001
Transparent cover, lockable, IP65	for cut-out 54 x 29 [2.13 x 1.14], for screw mounting to front bezel F1B or adapter front bezel N003001, for counters with cut-out 50 x 25 [1.97 x 0.98] or 45 x 22.2 [1.77 x 0.87]	N003002
Sealing cover type K1, IP65	suitable for front bezel 60 x 50 [2.36 x 1.97], for screw mounting of electromech. counters and via adapter front bezel N003001 for counters 48 x 24 [1.89 x 0.94]	G008301
Mounting frame with cut-out 50 x 25 [2.36 x 1.97] via separate adapter also for 45 x 22.2 [1.77 x 0.87]	for snap-on mounting on 35 [1.38] top-hat DIN rail, for counters 53 x 28 [2.09 x 1.10] and via separate adapter (T008180) for counters 48 x 24 [1.89 x 0.94] chromated	G300004

Suitable gaskets, other accessories and installation examples for optional accessories can be found in chapter accessories or in the accessories section under: www.kuebler.com/accessories.

Technical data

General technical data

Display	5 digits, red 7 segment LED display; 8 mm [0.32"] high
Measuring rate	10 measurements/second
Data backup	EEPROM
Operating temperature	-20°C ... +60°C [-4°F ... +140°F] (non-condensing)

Electrical characteristics

Power supply	10 ... 30 V DC, galvanically isolated with integrated reverse polarity protection
Current consumption	max. 50 mA
EMC standards	EN 55011 class B EN 61000-6-2, EN 61000-6-3 EN 61326-1
UL approval	file E128604

Mechanical characteristics

Housing	front panel mount 48x24 mm [1.89 x 0.94"] acc. to DIN 43700; RAL 7021, dark grey
Protection	IP65 (front side)
Weight	approx. 50 g [1.76 oz]
Vibration resistance acc. to EN 60068-2-6	10 ... 55 Hz / 1 mm [0.04"] / 30 min
Shock resistance acc. to EN 60068-2-27	100 G: 2 ms 10 G: 6 ms
Connections	screw terminal, pitch 5.08 mm [2"], 7 pin

Inputs

Input current measurement	0 ... 20 mA (display range 0.5 ... 20.5 mA, programmable)
Voltage drop	max. 1,5 V DC
Input voltage measurement	0 ... 10 V (display range 0.5 ... 10.5 V, programmable)
Control inputs	HIGH 4 ... 30 V DC Display hold LOW 0 ... 2 V DC
Resolution	14 bit
Accuracy	< 0.1 % for the whole measuring range at an operating temperature of 20°C [68°F]
Temperature drift	< 70 ppm/K _{Ambient}

Terminal assignment



PIN	
1	10 ... 30 V DC
2	GND
3	GND
4	Latch
5	0 (4) ... 20 mA
6	Analog GND
7	0 (2) ... 10 V DC

Process displays

LED process displays Standard signals with Min/Max value detection, totalizer Codix 534

Dimensions

Dimensions in mm [inch]

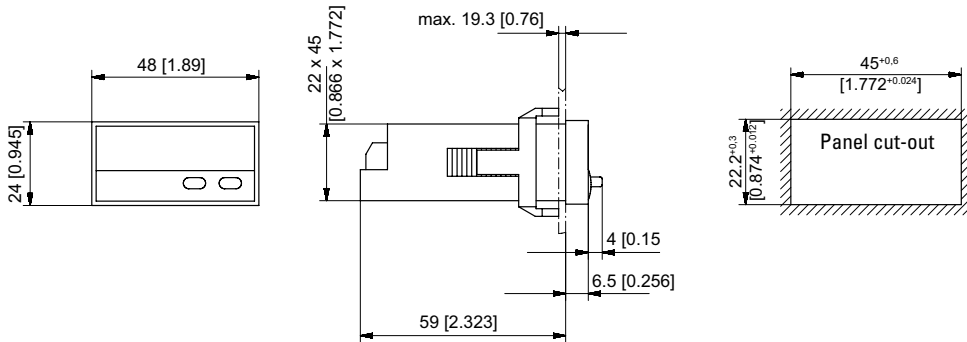

Front bezel for clip mounting (included in delivery)

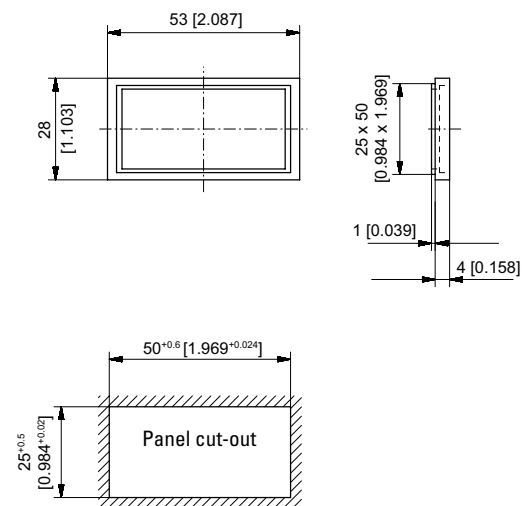

Front bezel for screw mounting (included in delivery)

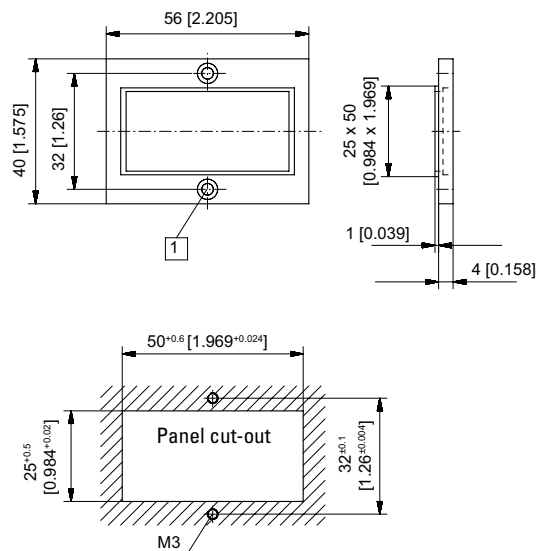

1 Countersinking Af3, DIN 74

Product overview
Basics

Pulse counters

Preset counters

Hour meters
Timers

Frequency displays
Tachometers

Position displays

Multifunction
devices

Energy meters

Process devices

Temperature
devices

Strain-gauge
controllers

Accessories
Index

LED process controllers For standard signal inputs (AC+DC) **Codix 565**



The process controller Codix 565 with totalizer function displays V and mA standard signal inputs in high resolution. In addition it can monitor and control 2 limit values.

These fast displays set new standards when it comes to user friendliness. Their easy-to-read 14-segment LED display, easy-to-understand running help texts and a practical quick-start guide eliminate the need to wade through time-consuming full instruction manuals.

With optional analog output.

Product overview
Basics
Pulse counters
Preset counters
Hour meters
Timers
Frequency displays
Tachometers
Position displays
Multifunction devices
Energy meters
Process devices
Temperature devices
Strain-gauge controllers
Accessories
Index

DC 10 ... 30 V Power supply	AC 100 ... 240 V Power supply	A..Z* 6 LEDs 14-segment LED display	Prog Menu-driven programming	mA, V Display linearization	Tara Tare function	Σ Totalizer-Function	mA, V Input	min / max Min / Max value detection	2 2 limit values	AC/DC Galvanic isolation
15 bit Resolution	-20° + 65° Temperature range	DIN 96 x 48 DIN front bezel	Installation in mosaic systems	Operation with gloves	mA, V Analog output optional					

User-friendly

- Practical quick-start guide for setting the parameters and operating the device.
- Help text as running text.
- Easy-to-read 14-segment LED display, 6 digits 14 mm [0.55] high.
- Simple programming via 4 keys on the front.
- One front key as well as 2 additional inputs can be programmed for specific applications.
- Customer-specific characteristic (linearization) curve via 12 control points for all measurement signal inputs.
- MIN/MAX memory function, individually resettable.

Powerful

- Sampling rate of 10 readings per second.
- Time-controlled totalizer function for totalizing the measured values. Can be reset separately.
- 2 relay outputs (changeover contacts) for limit monitoring with hysteresis and ON/OFF delay function for current measured or totalizer values.
- Analog output for the current measured value, MIN-value, MAX-value or totalizer value.
- Auxiliary sensor power supply 15 V DC / 25 mA, also for 2-wire transmitters.
- Inputs and outputs galvanically isolated .
- Digital filter (first-order) for smoothing display fluctuation with unstable input signals.
- Tare function.

Order code

6.56 **5** . 0 1 0 . **X** 0 **X**

a
b
c
d

- a** Input type
5 = standard signal input ¹⁾
- b** Outputs
0 = relays ¹⁾
- c** Power supply
0 = 100 ... 240 V AC, ± 10% ¹⁾
3 = 10 ... 30 V DC ¹⁾
- d** Further outputs (optional)
0 = none ¹⁾
9 = analog output
(only for DC version)

Delivery specification:

- Process device
- Mounting clip
- Gasket
- Instruction manual, multilingual
- 1 sheet of self-adhesive symbols
- Quick-start guide

Practical quick-start guide for setting the parameters and operating the device. The guide can be affixed directly to the front of the unit and can be removed and re-applied as required.



1) Stock types.

LED process controllers	For standard signal inputs (AC+DC)	Codix 565
--------------------------------	---	------------------

Accessories	Dimensions in mm [inch]	Order no.
Mounting frame with cut-out 92 x 45 [3.62 x 1.77]	for snap-on mounting on 35 [1.38] top-hat DIN rail, for counters 96 x 48 [3.74 x 1.89]	grey G300005

Suitable gaskets as well as further accessories can be found in the accessories section or in the accessories area of our website at: www.kuebler.com/accessories.

Technical data

General technical data	
Display	6-digit, 14 segment LED
Digit height	14 mm [0.55"]
Display range	-199999 ... 999999, with leading zero blanking
Data retention	> 10 years, EEPROM
Operation	5 keys
Operating temperature	-20°C ... +65°C [-4°F ... +149°F] (non-condensing)
Storage temperature	-25°C ... +75°C [-13°F ... +167°F]
Relative humidity (non-condensing)	R.H. 93 % at +40°C [+104°F]
Altitude	up to 2000 m [6562']

Electrical characteristics					
Power supply	<table style="width:100%; border: none;"> <tr> <td style="width: 10%; border: none;">AC supply</td> <td style="border: none;">100 ... 240 V AC / max. 9 VA 50 / 60 Hz, tolerance ±10% ext. fuse protection: T 0.1 A</td> </tr> <tr> <td style="border: none;">DC supply</td> <td style="border: none;">10 ... 30 V DC / max. 3.8 W with galvanic isolation and reverse polarity protection ext. fuse protection: T 0.4 A</td> </tr> </table>	AC supply	100 ... 240 V AC / max. 9 VA 50 / 60 Hz, tolerance ±10% ext. fuse protection: T 0.1 A	DC supply	10 ... 30 V DC / max. 3.8 W with galvanic isolation and reverse polarity protection ext. fuse protection: T 0.4 A
AC supply	100 ... 240 V AC / max. 9 VA 50 / 60 Hz, tolerance ±10% ext. fuse protection: T 0.1 A				
DC supply	10 ... 30 V DC / max. 3.8 W with galvanic isolation and reverse polarity protection ext. fuse protection: T 0.4 A				
Mains hum suppression	50 Hz or 60 Hz, programmable				
Sensor power supply	<table style="width:100%; border: none;"> <tr> <td style="width: 10%; border: none;">AC supply</td> <td style="border: none;">24 V DC ±15 %, 30 mA 15 V DC ± 1 %, 25 mA</td> </tr> <tr> <td style="border: none;">DC supply</td> <td style="border: none;">15 V DC ± 1 %, 25 mA</td> </tr> </table>	AC supply	24 V DC ±15 %, 30 mA 15 V DC ± 1 %, 25 mA	DC supply	15 V DC ± 1 %, 25 mA
AC supply	24 V DC ±15 %, 30 mA 15 V DC ± 1 %, 25 mA				
DC supply	15 V DC ± 1 %, 25 mA				
EMC standards	EN 55011 class B EN 61000-6-2, EN 61000-6-3 with shielded signal and control cables				
Device safety	designed to EN 61010 part 1 protection class 2 (front side) application area pollution level 2 overvoltage category II				
UL approval	file E128604				

Mechanical characteristics	
Housing	Panel mount housing to DIN 43700, RAL 7021
Dimensions	96 x 48 x 102 mm [3.78 x 1.89 x 4.02"]
Panel cut-out	92+0.8 x 45+0.6 mm [3.62+0.032 x 1.77+0.024"]
Installation depth	approx. 92 mm [3.62"] incl. terminals
Weight	approx. 180 g [6.34 oz] with analog output 200 g [7.06 oz]
Protection	IP65 (front side)
Housing material	Polycarbonate UL94 V-2
Vibration resistance acc. to EN 60068-2-6	10 ... 55 Hz / 1 mm / XYZ 30 min in each direction
Shock resistance acc. to EN 60068-2-27	100G / 2 ms / XYZ 3 times in each direction
acc. to EN 60068-2-29	10G / 6 ms / XYZ 2000 times in each direction
Connections	
Power supply and outputs	Plug-in screw terminal, 8-pin, RM 5.00, core ø max. 2.5 mm² [AWG 13]
Signal and control inputs	Plug-in screw terminal, 9-pin, RM 3.50, core ø max. 1.5 mm² [AWG 15]

Measuring signal inputs	
Sampling rate	10 readings/sec
Voltage input	
Input signal	0 ... 10 V, 2 ... 10 V, ± 10 V
Measuring range	-10.5 ... +10.5 V
Resolution	< 0.4 mV (±15 bit)
Measuring accuracy at 23°C [73°F] (% of range)	typ. 0.02 % / max. ≤ 0.05 %
Temperature drift	< 100 ppm/K _{Ambient}
Input resistance	1 MΩ
Max. voltage	± 30 V
Current input	
Input signal	0 ... 20 mA, 4 ... 20 mA
Measuring range	-0.5 ... 21 mA
Resolution	1 µA (> 14 bit)
Measuring accuracy at 23°C [73°F] (% of range)	typ. 0.02 % / max. ≤ 0.05 %
Temperature drift	< 100 ppm/K _{Ambient}
Input resistance	22 Ω + PTC 25 Ω
Voltage drop	approx. 1.8 V at 20 mA
Max. current	60 mA

Product overview
 Basics
 Pulse counters
 Preset counters
 Hour meters
 Timers
 Frequency displays
 Tachometers
 Position displays
 Multifunction devices
 Energy meters
 Process devices
 Temperature devices
 Strain-gauge controllers
 Accessories
 Index

Process controllers

LED process controllers For standard signal inputs (AC+DC) Codix 565

Control inputs MPI 1 / MPI 2	
Quantity	2 optocouplers
Function	programmable
Switching levels	LOW < 2 V HIGH > 4 V (max. 30 V)
Pulse length	> 100 ms

Analog output (optional - only for DC version)	
Output ranges	0 (4) ... 20 mA / 0 (2) ... 10 V
Load	current output $\leq 500 \Omega$ voltage output $\geq 2000 \Omega$
Resolution	15 bit
Update time (basic device measuring rate)	100 ms
Temperature drift	$\leq 100 \text{ ppm/K}_{\text{Ambient}}$
Accuracy	$\pm 0.1\%$ of the output range high value
Output ripple	$\leq 10 \text{ mV}$
Isolation voltage	500 V AC for 1 minute or 1 kV DC for 1 second

Alarm outputs	
Relays	changeover contacts
Switching voltage	max. 250 V AC / 125 V DC min. 5 V AC / 5 V DC
Switching current	max. 5 A AC / 5 A DC min. 10 mA DC
Switching capacity	max. 1250 VA / 150 W

Block diagram

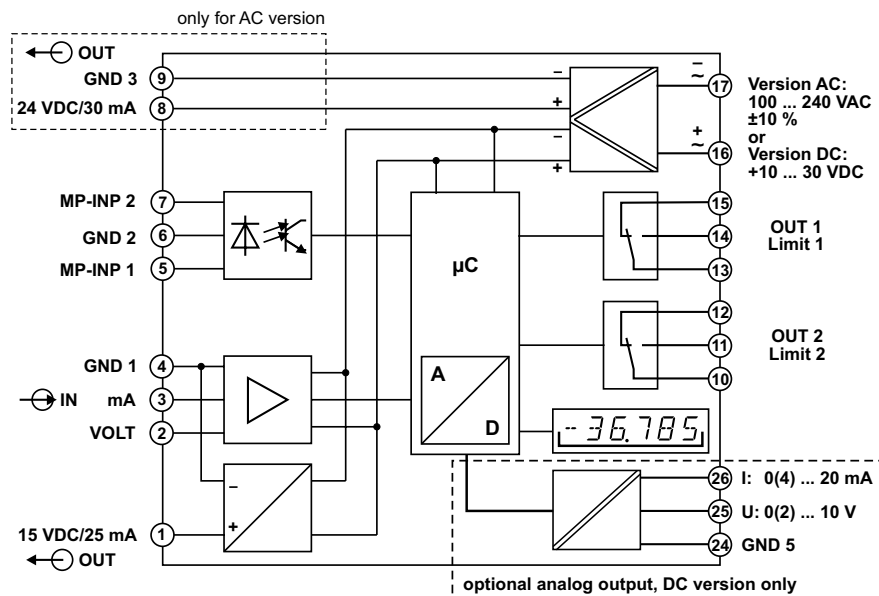

LED process controllers For standard signal inputs (AC+DC) **Codix 565**

Terminal assignment

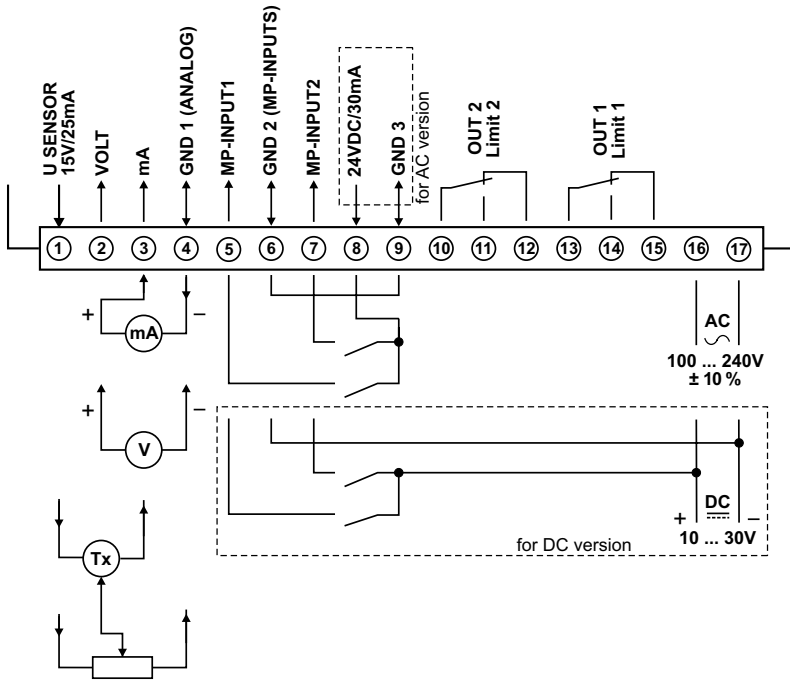

Rear side view

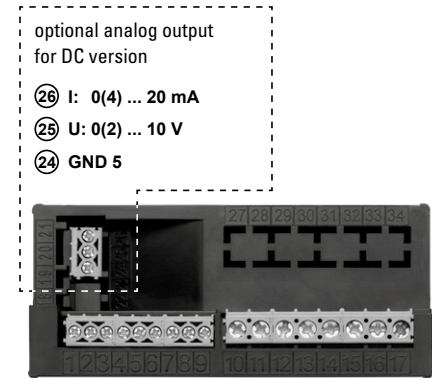

Dimensions

Dimensions in mm [inch]

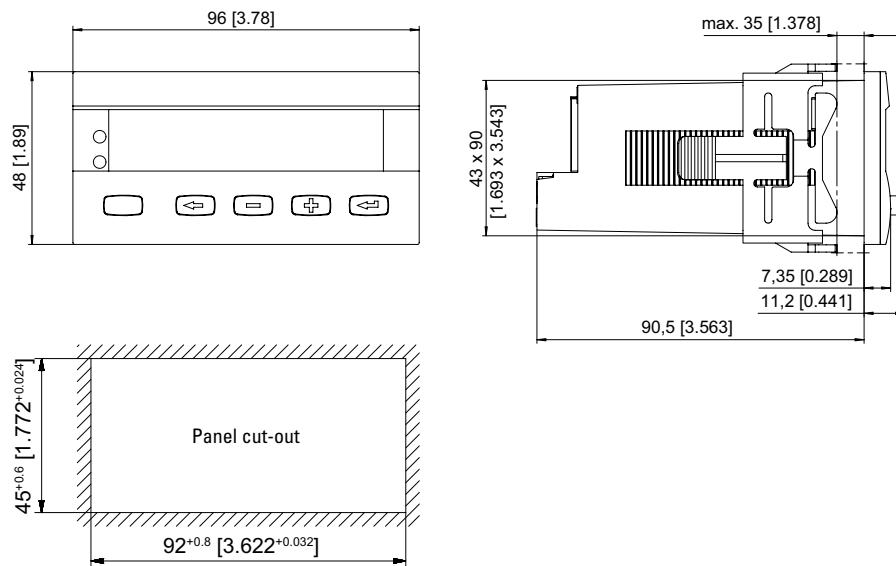

Product overview
Basics

Pulse counters

Preset counters

Hour meters
Timers

Frequency displays
Tachometers

Position displays

Multifunction
devices

Energy meters

Process devices

Temperature
devices

Strain-gauge
controllers

Accessories
Index

LCD touch process controllers **2 standard signal inputs + analog and switching outputs** **573T**



The process controller with 2 analog inputs can be used in both single channel mode as well as in dual channel. In dual channel mode, all arithmetic operations are available for displaying the sum total, difference, ratio or the product. Inputs and outputs can be scaled separately.

Can be used as a simple process signal converter, process controller (ON/OFF controller) or for complex measuring tasks, where the relationship between two values, one to the other, must be monitored, calculated or further processed in a higher-level controller.

Product overview
Basics
Pulse counters
Preset counters
Hour meters
Timers
Frequency displays
Tachometers
Position displays
Multifunction devices
Energy meters
Process devices
Temperature devices
Strain-gauge controllers
Accessories
Index

AC 115... 230V Power supply	DC 18... 30 V 2 inputs	mA, V 2 inputs	4 4 switching outputs	2 Relay output	mA, V Analog output	16 bit Resolution analog output	RS 232 / RS485 interface	IP65 High protection level	Tara Tare function	DIN 96 x 48 DIN front bezel
8 LCDs LCD touch display	Menu-driven programming	Touch display	Operation with gloves							

Innovative

- 2 separate freely scalable analog inputs ± 10 V and 0/4 ... 20 mA, resolution 16 bit.
- Tare function – the unit can be set to 0 for any input voltage.
- Programmable linearization: with up to 24 control points, input via key-pad or via the teach-in function.
- Averaging measurement over 2 to 16 measuring cycles, for use with serious fluctuations of the input signals.
- Easy to programme - the desired display value is simply keyed-in for a specific input signal.
- Fast 1 ms sampling rate per channel alternating.
- Serial interface RS232 or RS485 for reading data in and out.

Compact and multifunctional

- Up to 3 display values in one device, display 1, display 2 + display calculated based on 1 and 2.
- AC and DC power supply in one device.
- Simple menu-driven programming via touch display, as well as tare or teach-in key.
- Can be used as a simple process signal converter, process controller (ON/OFF controller) or for complex measuring tasks where the relationship between two values, one to the other, must be monitored, calculated or further processed in a higher-level controller.
- Mathematical operation of the measured values of inputs 1 and 2. The result can also if required be multiplied, divided or added to an offset value, in order to obtain the desired display value.
- Analog output 0/4 ... 20 mA or ± 10 V.
- 4 fast PNP switching outputs (reaction time < 1 ms), with switching hysteresis, step or tracking preset.
- Programmable display refresh time.

Order code

6.573T . 01X . X0X
a b c d

a Relay outputs
0 = 2 relay outputs
2 = without output

b Power supply
3 = 18 ... 30 V DC
E = 18 ... 30 V DC + 115 ... 230 V AC

c Further options
0 = none

d Electrical outputs
0 = none
1 = RS232, 4 switching outputs
2 = RS232, 4 switching outputs, analog output
3 = RS485, 4 switching outputs

Delivery specification

- Display 573T
- Gasket
- Mounting kit
- Manual German/English

Stock types

- 6.573T.012.301
- 6.573T.012.302
- 6.573T.010.302
- 6.573T.010.E02

Process controllers

LCD touch process controllers	2 standard signal inputs + analog and switching outputs	573T
--------------------------------------	--	-------------

Accessories		Order no.
Mounting frame with cut-out 92 x 45 [3.62 x 1.77]	for snap-on mounting on 35 [1.38] top-hat DIN rail, for counters 96 x 48 [3.74 x 1.89]	grey G300005
OS6.0 software for parameter setting	can be downloaded at www.kuebler.com	

Suitable gaskets as well as further accessories can be found in the accessories section or in the accessories area of our website at: www.kuebler.com/accessories.

Technical data

General technical data	
Display	LCD touch display, 13 mm high 8 decades + sign
Operating temperature	-20°C ... +60°C [-4°F ... +140°F] (non-condensing)
Storage temperature	-25°C ... +70°C [-13°F ... +158°F]
Altitude	up to 2000 m [6562']
Electrical characteristics	
Power supply	18 ... 30 V DC, with reverse polarity protection (rated voltage 24 V DC) 115 ... 230 V AC, 50/60 Hz (option)
Current consumption DC	100 mA, without load
Power consumption AC	approx. 3 VA, without load
Auxiliary power supply (for encoder)	
AC supply	24 V DC ±15 %, 150 mA (up to +45°C) 80 mA (from +46°C)
DC supply	U _B - 1 V, 250 mA
Reference output	
output voltage	10 V DC
accuracy	±0.1 %
load	max. 10 mA / ≥ 1 kΩ
EMC standards	EN 61000-6-2, EN 61000-6-3, EN 61000-6-4, EN 61326-3-2
Device safety	
designed to protection class	EN 61010 part 1 2
application area	pollution level 2

Mechanical characteristics	
Housing	ABS UL94-V-0
Weight	approx. 200 g
Protection	IP65 (front side) IP20 (rear side)
Terminals	max. 1.5 mm ²

Inputs	
2 analog inputs	0 ... 20 mA, 4 ... 20 mA -10 ... +10 V
input resistance current	R _i = 120 Ω
input resistance voltage	R _i = 50 kΩ
measuring time per channel	min. 1 ms (programmable)
resolution	16 bit (15 bit + sign)
accuracy	±0.1 % ±1 digit
3 control inputs (Cnt 1 - 3)	PNP
input frequency	max. 10 kHz
input level	HTL: Low 0 ... 3 V / High 9 ... 30 V
load	max. 2 mA / R _i > 15 kΩ / 470 pF

Outputs (option)	
4 switching outputs	5 ... 30 V DC/200 mA (PNP)
reaction time	< 1 ms
Interface	RS232 or RS485 Drivecom Protokoll / Modbus / Printer 9600 ... 38400 Baud
Analog output	-10 ... +10 V (max. 2 mA) or 0 ... 20 mA, 4 ... 20 mA (max. 270 Ω)
resolution	16 bit (15 bit + sign)
accuracy	±0.1 %
reaction time	< 1 ms
Relay output	2 changeover contacts (potential free) max. 250 V AC / 3 A / 750 VA max. 150 V DC / 2 A / 50 W
reaction time	< 20 ms

Product overview
Basics
Pulse counters
Preset counters
Hour meters
Timers
Frequency displays
Tachometers
Position displays
Multifunction devices
Energy meters
Process devices
Temperature devices
Strain-gauge controllers
Accessories
Index

Process controllers

LCD touch process controllers **2 standard signal inputs + analog and switching outputs** **573T**

Application examples

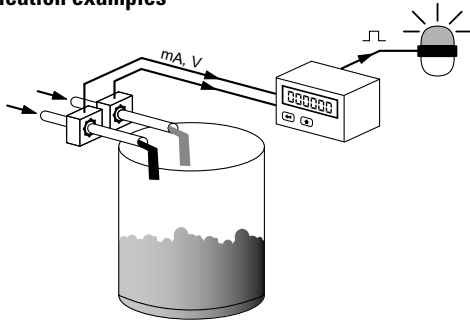

Monitoring of mixing ratios and display of flow rate

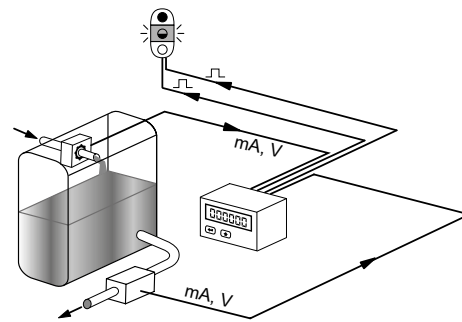

Level monitoring and adjustment, display of inflow and outflow

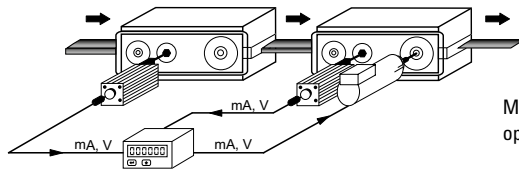

Material stretching, as well as monitoring of synchronous operation, with display of individual speeds

Connection example

Analog input, analog output, switching outputs

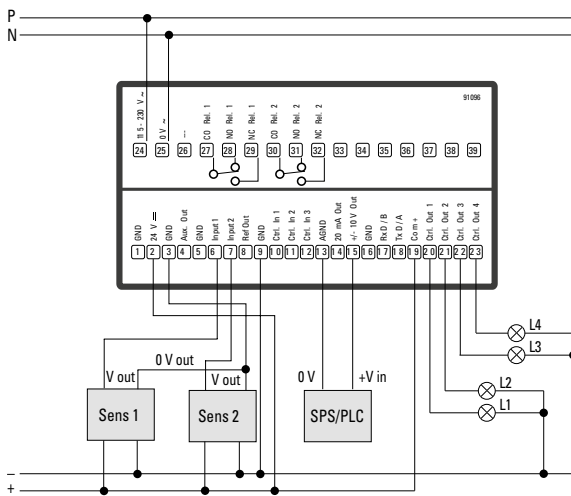

Analog input, switching outputs, interface RS232

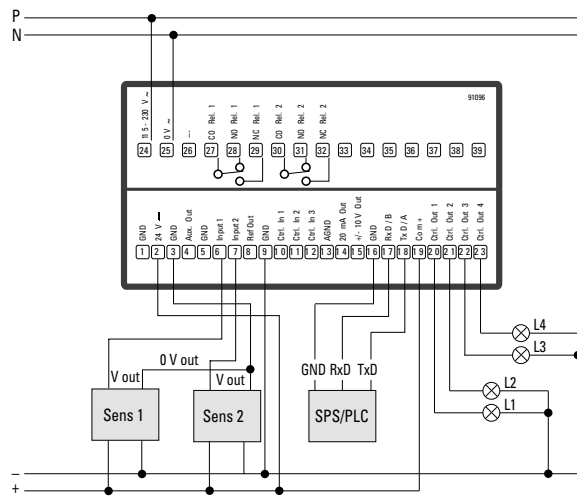

Analog input, analog output, load output (relay), switching outputs

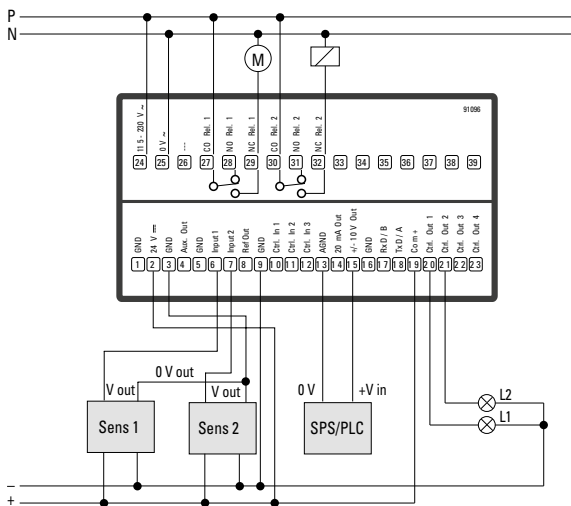

Product overview
Basics

Pulse counters

Preset counters

Hour meters
Timers

Frequency displays
Tachometers

Position displays

Multifunction
devices

Energy meters

Process devices

Temperature
devices

Strain-gauge
controllers

Accessories
Index

LCD touch process controllers **2 standard signal inputs + analog and switching outputs** **573T**

Terminal assignment

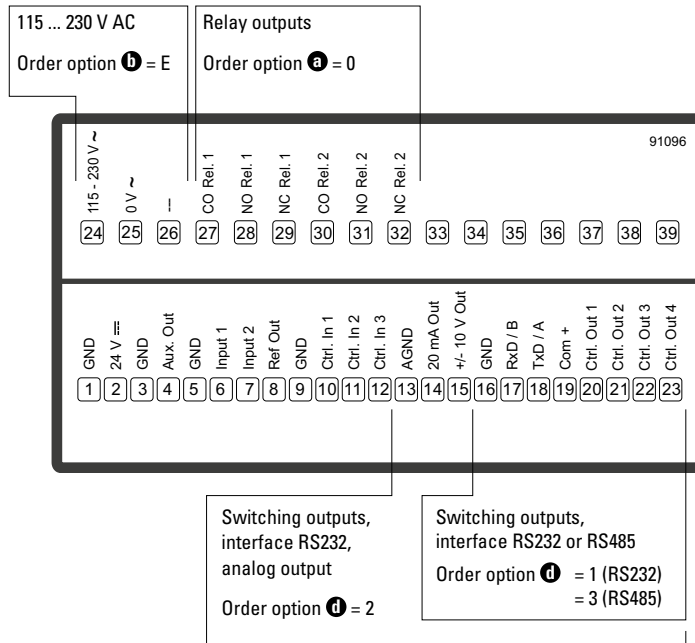

Dimensions

Dimensions in mm [inch]

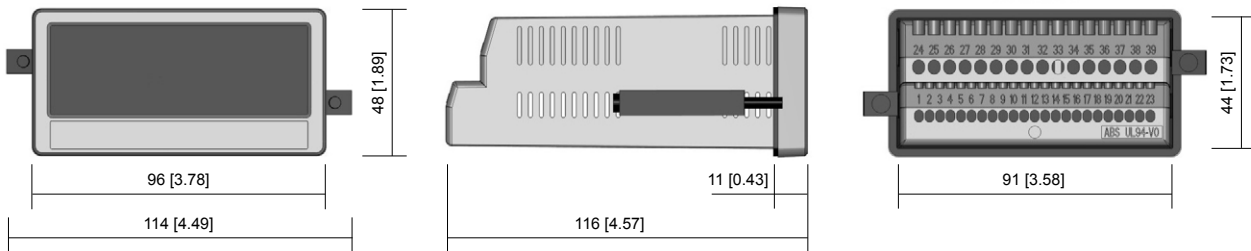

Panel cut-out
92 x 45 mm [3.62 x 1.77"]

Setpoint adjuster

LED setpoint adjuster **Standard signal output for mA or V, also time-controlled (DC)** **Codix 533**



The setpoint adjuster Codix 533 triggers a standard analog signal or a freely programmable signal sequence from 0 ... 12 V or from 0 ... 24 mA.

The setpoint adjuster is a real innovation, opening up new application potentials in process technology and automation.



DIN 48 x 24	4 LED	DC 10 ... 30 V	Menu-driven programming	IP65	-20° + 65° Temperature range	mA, V Output	Galvanic isolation AC/DC
--------------------	--------------	--------------------------	--------------------------------	-------------	--	------------------------	------------------------------------

Innovative

- Function of a digital time controller with analog output.
- Manual functions with direct input or stepped incremental output of the setpoint.
- 4-digit, 8 mm high top-quality LED display.
- Physical variables output / 0 ... 12 V or 0 ... 24 mA analog signals.
- Units of display can be freely programmed and displayed – no conversion of the specified output value required.
- Ideal for simulation runs without the need for expensive, time-consuming running-in of processes.

Powerful

- Simpler to run processes than with a PLC or process controller.
- Everything can be programmed easily by means of 2 keys and the text menu.
- Digital setting - no additional DIP switches or potentiometers.
- Display allows simple monitoring of the specified setpoint output.
- User-friendly display form as direct digital value.
- 3 separate functions integrated as standard in the Codix 533.
- High accuracy of < 0.2% of the final value.

Order no.

Setpoint adjuster **6.533.012.300 ¹⁾**

Delivery specification

- Setpoint adjuster
- Mounting clip
- Gasket
- Front bezel for screw mounting (T008181) 56 x 40 mm [2.20 x 1.57"], panel cut-out 50 x 25 mm [1.97 x 0.98"]
- Front bezel for clip mounting (T008180) 53 x 28 mm [2.09 x 1.10"], panel cut-out 50 x 25 mm [1.97 x 0.98"]
- 1 set of self-adhesive symbols
- Instruction manual, multilingual

1) Stock types

Setpoint adjuster

LED setpoint adjuster	Standard signal output for mA or V, also time-controlled (DC)	Codix 533
------------------------------	--	------------------

Accessories	Dimensions in mm [inch]	Order no.
Adapter front bezel, 72 x 36 [2.83 x 1.42]	for cut-out 68 x 33 [2.68 x 1.30] to cut-out 45 x 22.2 [1.77 x 0.87], for counters 48 x 24 [1.89 x 0.94], as set black and silver anodized	162704 Set
Adapter front bezel, 48 x 48 [1.89 x 1.89]	for cut-out 45 x 45 [1.77 x 1.77] to cut-out 45 x 22.2 [1.77 x 0.87], with clip mounting for counters 48 x 24 [1.89 x 0.94] black	T008883
Adapter front bezel, 60 x 50 [2.36 x 1.97]	for cut-out 54 x 29 [2.13 x 1.14] to cut-out 45 x 22.2 [1.77 x 0.87], with screw mounting and gasket for counters 48 x 24 [1.89 x 0.94] black	N003001
Transparent cover, lockable, IP65	for cut-out 54 x 29 [2.13 x 1.14], for screw mounting to front bezel F1B or adapter front bezel N003001, for counters with cut-out 50 x 25 [1.97 x 0.98] or 45 x 22.2 [1.77 x 0.87]	N003002
Sealing cover type K1, IP65	suitable for front bezel 60 x 50 [2.36 x 1.97], for screw mounting of electromech. counters and via adapter front bezel N003001 for counters 48 x 24 [1.89 x 0.94]	G008301
Mounting frame with cut-out 50 x 25 [2.36 x 1.97] via separate adapter also for 45 x 22.2 [1.77 x 0.87]	for snap-on mounting on 35 [1.38] top-hat DIN rail, for counters 53 x 28 [2.09 x 1.10] and via separate adapter (T008180) for counters 48 x 24 [1.89 x 0.94] chromated	G300004

Suitable gaskets, other accessories and installation examples for optional accessories can be found in chapter accessories or in the accessories section under: www.kuebler.com/accessories.

Technical data

General technical data	
Display	4 digits, red 7 segment LED display, 8 mm [0.32"] high
Data backup	EEPROM
Operating temperature	-20°C ... +65°C [-4°F ... +149°F] (non-condensing)
Storage temperature	-25°C ... +85°C [-13°F ... +185°F]

Electrical characteristics	
Power supply	10 ... 30 VDC, galvanically isolated with integrated reverse polarity protection
Power consumption	max. 1 W
Test voltage	500 V, 50 Hz, 1 min.
EMC standard	EN 55011 class B EN 61000-6-2, EN 61000-6-3
UL approval	file E128604

Mechanical characteristics	
Housing	front panel mount 48 x 24 mm [1.89 x 0.94"] acc. to DIN 43700; RAL 7021, dark grey
Protection	IP65 (front side)
Weight	approx. 50 g [1.76 oz]
Connections	screw terminal, pitch 5.08 mm [2"], 7 pin

Standard signal outputs / control input	
Current output	0 ... 24 mA, increment 10 µA load 20 mA: ≤ 500 Ohm > 20 mA: ≤ 400 Ohm
Voltage output	0 ... 12 V, increment 10 mV load ≥ 2 kOhm
Control input	HIGH 4 ... 30 V DC Hold (HIGH active) LOW 0 ... 2 V DC
Accuracy	< 0.2% of the full scale value ±0.02 %/K _{Ambient}

Product overview
Basics

Pulse counters

Preset counters

Hour meters
Timers

Frequency displays
Tachometers

Position displays

Multifunction
devices

Energy meters

Process devices

Temperature
devices

Strain-gauge
controllers

Accessories
Index

Setpoint adjuster

LED setpoint adjuster	Standard signal output for mA or V, also time-controlled (DC)	Codix 533
------------------------------	--	------------------

3 operating modes programmable

Manual direct input (Setp)

- Fast adjustment and manual approach to the desired setpoint value.
- Setpoint value can be specified directly during operation via the keys in V or mA.
- Output of the value 3 seconds after the last key actuation.

Manual ramping function (Man)

- Possibility of a stepped, incremental approach to the desired setpoint value using the keys on the front.
- Input of the minimum and maximum setpoint values and the increment by key actuation in the programming level.
- During operation the device starts with the minimum setpoint value – the right key is used to increase the value by the amount of the increment; the left key decreases the value.
- The programmed maximum value cannot be exceeded.

Automatic ramping function (Auto)

- Function of a digital time based controller with analog output. Setpoint values can be programmed and carried out for process sequences, either cyclic or time dependent: irrigating, dosing, lubricating, filling, venting, mixing.
- With max. 20 current or voltage values.
- Cyclically limited (time) or unlimited.

Example of an automatic ramping function

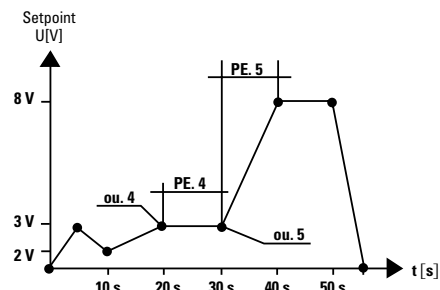

Example with 8 points	
ou. 1	0 V
PE 1	5 s
ou.2	3 V
PE 2	5 s
ou. 3	2 V
PE 3	10 s
ou. 4	3 V
PE 4	10 s
ou. 5	3 V
PE 5	10 s
ou. 6	8 V
PE 6	10 s
ou. 7	8 V
PE 7	10 s
ou. 8	0 V
PE 8	5 s

Block diagram

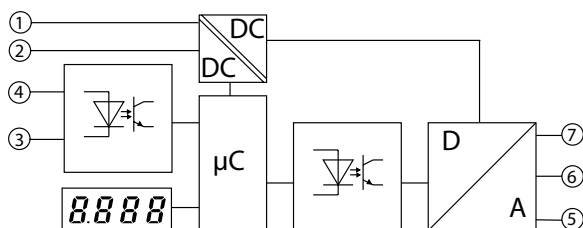

Inputs

1	2	3	4
10 ... 30 V DC	GND_1	GND_2	Hold

Outputs

5	6	7
0 ... 24 mA (Iout)	GND_3	0 ... 12 V DC Uout

Terminal assignment

Inputs

1	2	3	4
10 ... 30 V DC	GND_1	GND_2	Hold

Outputs

5	6	7
0 ... 24 mA	Analog GND_3	0 ... 12 V DC

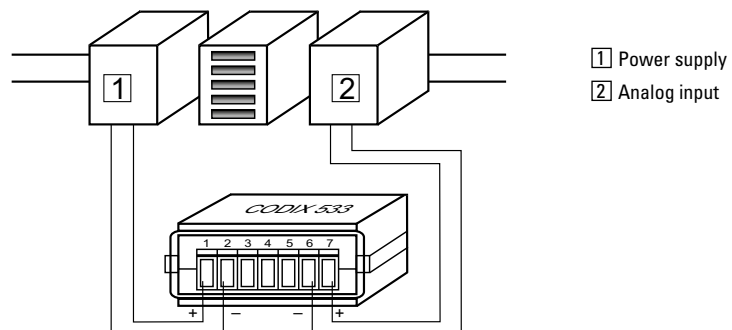

- 1 Power supply
- 2 Analog input

Product overview Basics
 Pulse counters
 Preset counters
 Hour meters Timers
 Frequency displays Tachometers
 Position displays
 Multifunction devices
 Energy meters
 Process devices
 Temperature devices
 Strain-gauge controllers
 Accessories Index

Setpoint adjuster

LED setpoint adjuster **Standard signal output for mA or V, also time-controlled (DC)** **Codix 533**

Dimensions

Dimensions in mm [inch]

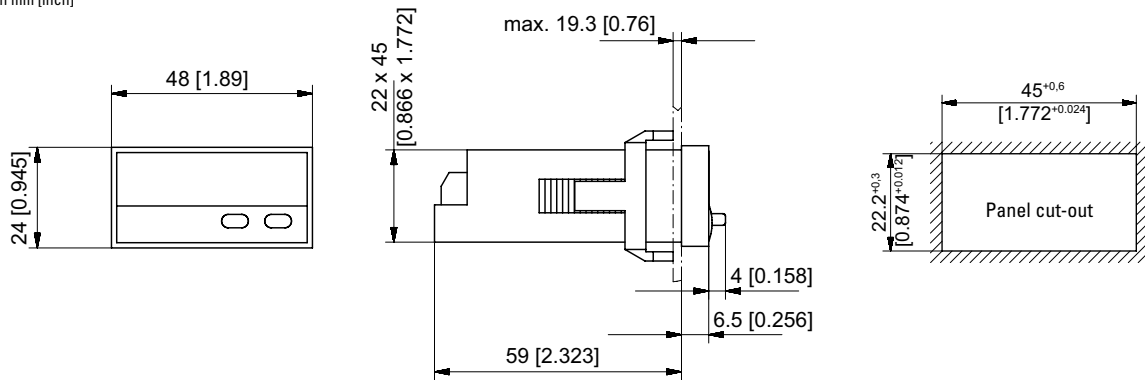

Front bezel

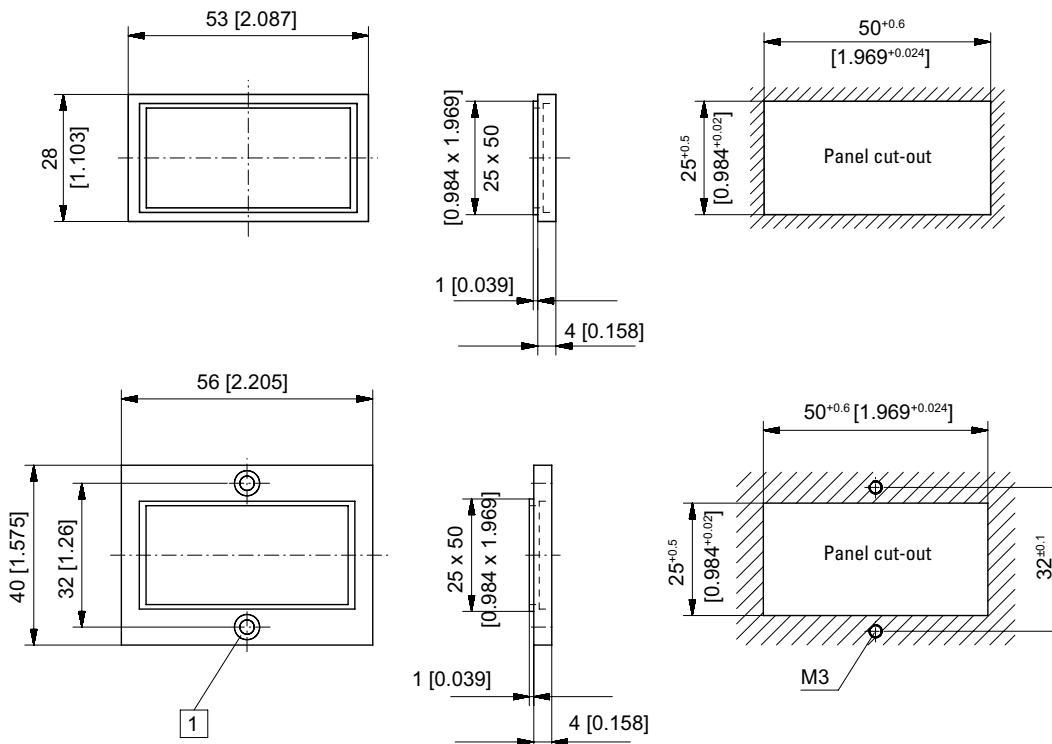

1 Countersinking Af3, DIN 74

Product overview
Basics
Pulse counters
Preset counters
Hour meters
Timers
Frequency displays
Tachometers
Position displays
Multifunction devices
Energy meters
Process devices
Temperature devices
Strain-gauge controllers
Accessories
Index

Setpoint adjuster

LED setpoint adjuster	Standard signal output for mA or V, also time-controlled (DC)	Codix 533
------------------------------	--	------------------

Areas of application / Applications

Simple control (fixed installation) in plants, machines and devices

Time-based ramping up or down of:

Rotary speeds (e.g. frequency converter), flow rates, temperatures, positions, pressure and fill levels.
In short: all physical quantities that can be represented with analog standard signals.

For use in set-up mode of plants, machines and devices

Manual (direct) specification or time-based or manual setting (ramping up or down) of:

Applications

Simple time controller with standard signal output

Commissioning, running-in processes or rotary speed control of motors through setpoint setting.

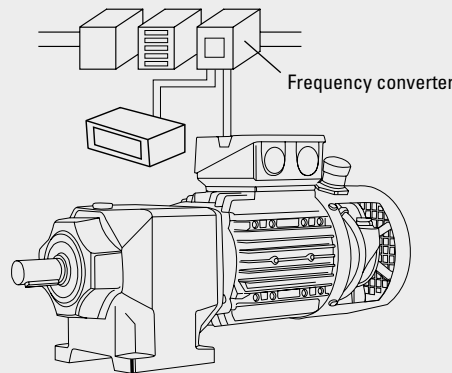

Control of simple, time-based processes by means of an analog signal, e.g. ramping control for locks and sluices

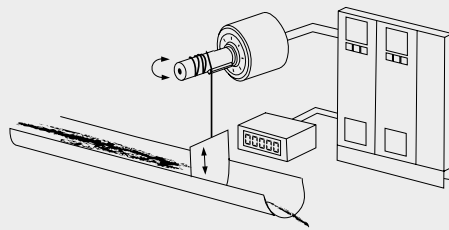

Calibration of filling levels and flow rates: the setpoint adjuster simulates the output signals of a level or flow sensor for configuring a control.

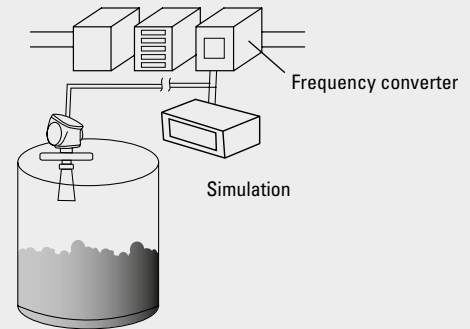

Alignment for temperature-based processes without having to heat up the plant: the setpoint adjuster can simulate various processes for test purposes.

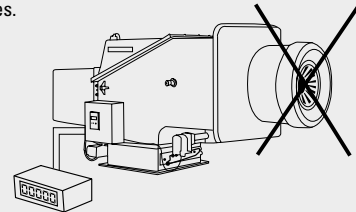

Solution with different modes

2 operating modes are provided for that purpose:
- Manual ramping function
- Automatic ramping function

The following operating modes are provided for that purpose:
- Manual direct input
- Manual ramping function
- Automatic ramping function

Advantages

Instead of using an expensive, complex and difficult-to-use PLC, our setpoint adjuster can handle this task as a standalone device. The user saves costs and the task can be performed in a flexible and quick way, even without any prior knowledge.

The setpoint adjuster simulates the sensor signal that is read by the physical process, e.g. the rise of the temperature, the filling of tank plants. Expensive and complex running-in of processes can be replaced with the simulation performed by the setpoint adjuster.

The output signal can be displayed directly or scaled in any desired unit.
The user always sees the exact progress.
An easy-to-use device with three selectable modes is available.

- Product overview Basics
- Pulse counters
- Preset counters
- Hour meters Timers
- Frequency displays Tachometers
- Position displays
- Multifunction devices
- Energy meters
- Process devices
- Temperature devices
- Strain-gauge controllers
- Accessories Index



Temperature displays / Temperature controllers

Temperature displays		Type	Page
LED temperature displays	Pt100 and Ni100 input (DC)	Codix 531	288
	For thermocouple inputs J, K and N (DC)	Codix 532	291
	mV, resistance, thermocouple inputs (AC+DC)	Codix 564	294
Temperature controller		Type	Page
LED temperature controller	mV, resistance, thermocouple inputs, 2 limit values (AC+DC)	Codix 564	294

Product overview
Basics

Pulse counters

Preset counters

Hour meters
Timers

Frequency displays
Tachometers

Position displays

Multifunction
devices

Energy meters

Process devices

Temperature
devices

Strain-gauge
controllers

Accessories
Index

Temperature displays

LED temperature displays

Pt100 and Ni100 input (DC)

Codix 531



Cost-effective temperature display for front panel mount with bright 5-digit LED display for values in °C or °F.

For very accurate temperature measurements using Pt100 and Ni100 resistance thermometers in 2, 3 or 4-wire technology, with permanently stored characteristic curves.

Minimum and maximum value detection for temperature monitoring over long periods of time.



DC 10 ... 30V Power supply	 2, 3, 4 2-, 3-, 4-wire technology	 Pt100 / Ni100	 Menu-driven programming	 AC/DC Galvanic isolation	 - 20° + 65° Temperature range	 IP65 High protection level	 min / max Min / Max value detection	 DIN 48 x 24 DIN front bezel	 5 LED LED display
---	--	-------------------	-----------------------------	---------------------------------	--------------------------------------	-----------------------------------	--	------------------------------------	--------------------------

Product features

- Input range: resistance thermometer.
- Compact and low-price temperature display.
- Easy programming and operation.
- Modern industrial design.
- 5 measurements/second.

Benefits

- Temperature display in °C or °F.
- MIN/MAX value acquisition and data backup in case of power off.
- Galvanic isolation with protection against incorrect polarity.
- Screw terminal connection: pitch 5 mm.
- Display hold input.

Order no.

Temperature display for Pt100 and Ni100 resistance thermometer

6.531.012.300 ¹⁾

Delivery specification

- Digital display
- Mounting clip
- Gasket
- Front bezel for screw mounting (T008181) 56 x 40 mm [2.20 x 1.57"], panel cut-out 50 x 25 mm [1.97 x 0.98"]
- Front bezel for clip mounting (T008180) 53 x 28 mm [2.09 x 1.10"], panel cut-out 50 x 25 mm [1.97 x 0.98"]
- 1 set of self-adhesive symbols
- Instruction manual, multilingual

1) Stock types.

Product overview Basics
Pulse counters
Preset counters
Hour meters Timers
Frequency displays Tachometers
Position displays
Multifunction devices
Energy meters
Process devices
Temperature devices
Strain-gauge controllers
Accessories Index

Temperature displays

LED temperature displays	Pt100 and Ni100 input (DC)	Codix 531	
Accessories	Dimensions in mm [inch]		Order no.
Adapter front bezel, 72 x 36 [2.83 x 1.42]	for cut-out 68 x 33 [2.68 x 1.30] to cut-out 45 x 22.2 [1.77 x 0.87], for counters 48 x 24 [1.89 x 0.94], as set	black and silver anodized	162704 Set
Adapter front bezel, 48 x 48 [1.89 x 1.89]	for cut-out 45 x 45 [1.77 x 1.77] to cut-out 45 x 22.2 [1.77 x 0.87], with clip mounting for counters 48 x 24 [1.89 x 0.94]	black	T008883
Adapter front bezel, 60 x 50 [2.36 x 1.97]	for cut-out 54 x 29 [2.13 x 1.14] to cut-out 45 x 22.2 [1.77 x 0.87], with screw mounting and gasket for counters 48 x 24 [1.89 x 0.94]	black	N003001
Transparent cover, lockable, IP65	for cut-out 54 x 29 [2.13 x 1.14], for screw mounting to front bezel F1B or adapter front bezel N003001, for counters with cut-out 50 x 25 [1.97 x 0.98] or 45 x 22.2 [1.77 x 0.87]		N003002
Sealing cover type K1, IP65	suitable for front bezel 60 x 50 [2.36 x 1.97], for screw mounting of electromech. counters and via adapter front bezel N003001 for counters 48 x 24 [1.89 x 0.94]		G008301
Mounting frame with cut-out 50 x 25 [2.36 x 1.97] via separate adapter also for 45 x 22.2 [1.77 x 0.87]	for snap-on mounting on 35 [1.38] top-hat DIN rail, for counters 53 x 28 [2.09 x 1.10] and via separate adapter (T008180) for counters 48 x 24 [1.89 x 0.94]	chromated	G300004

Suitable gaskets, other accessories and installation examples for optional accessories can be found in chapter accessories or in the accessories section under: www.kuebler.com/accessories.

Technical data	
General technical data	
Display	5 digits, red 7 segment LED display; 8 mm [0.32"] high
Display refresh	1 ... 2 times per second
Data backup	EEPROM
Operating temperature	-20°C ... +65°C [-4°F ... +149°F] (non-condensing)
Electrical characteristics	
Power supply	10 ... 30 VDC, galvanically isolated with integrated reverse polarity protection
Current consumption	max. 40 mA
Circuit type	2-wire, 3-wire and 4-wire technology, programmable
EMC standards	EN 55011 class B EN 61000-6-2, EN 61000-6-3 EN 61326-1
UL approval	file E128604
Mechanical characteristics	
Housing	front panel mount 48 x 24 mm [1.89 x 0.94"] acc. to DIN 43700; RAL 7021, dark grey
Protection	IP65 (front side)
Weight	approx. 50 g [1.76 oz]
Connections	screw terminal, pitch 5.08 mm [2"], 7 pin
Measuring signal inputs	
Measuring rate	5 measurements / second
Input	Pt100 resistance thermometer Ni100 resistance thermometer with sensor breakage monitoring
Control inputs	HIGH 4 ... 30 V DC LOW 0 ... 2 V DC
Supply current	1 mA
Supply line	2-wire max. 20 Ω, programmable 3-wire, 4-wire max. 20 Ω, no balancing required
Temperature ranges	Pt100 acc. to DIN IEC 751 -199.9°C ... +850.0°C [-327.8°F ... +1562.0°F] Ni100 acc. to DIN 43760 -60.0°C ... +250.0°C [-76.0°F ... +482.0°F]
Resolution	0.1°C (0.1°F) or 1°C (1°F)
Linearity error	Pt100 < 0.1 % for the whole measuring range at an operating temperature of 20°C [68°F] Ni100 < 0.2 % for the whole measuring range at an operating temperature of 20°C [68°F]
Temperature drift	0.1 K/K _{Ambient}

Temperature displays

LED temperature displays

Pt100 and Ni100 input (DC)

Codix 531

Terminal assignment

1	2	3	4	5	6	7
10 ... 30 V DC	0 V DC (GND)	Latch input	Pt100/Ni100	Pt100/Ni100	Pt100/Ni100	Pt100/Ni100

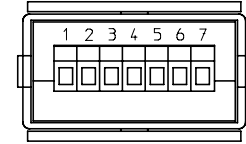

Connection power supply and latch input

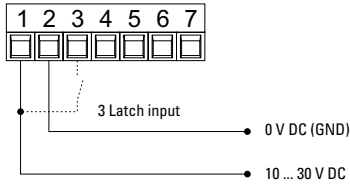

Connection resistance thermometer Pt100/Ni100

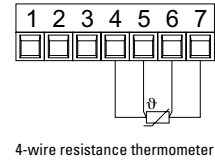
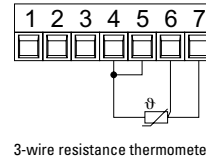
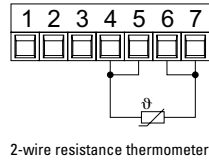

Dimensions

Dimensions in mm [inch]

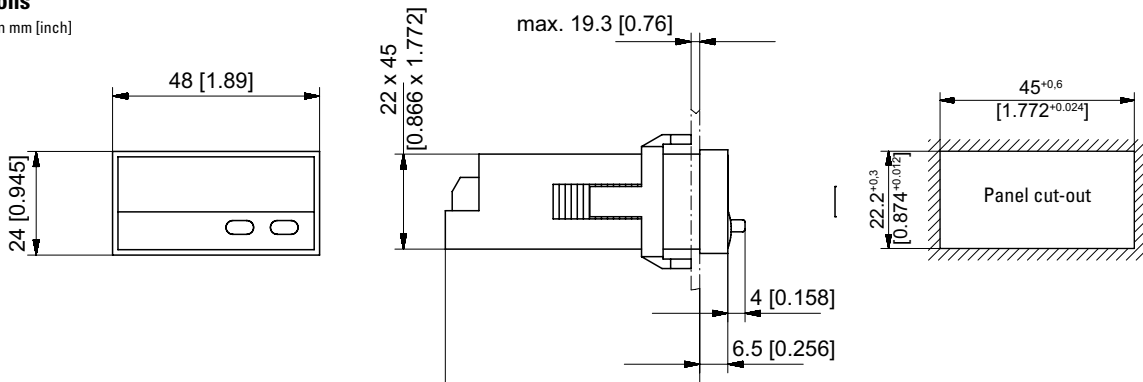

Front bezel

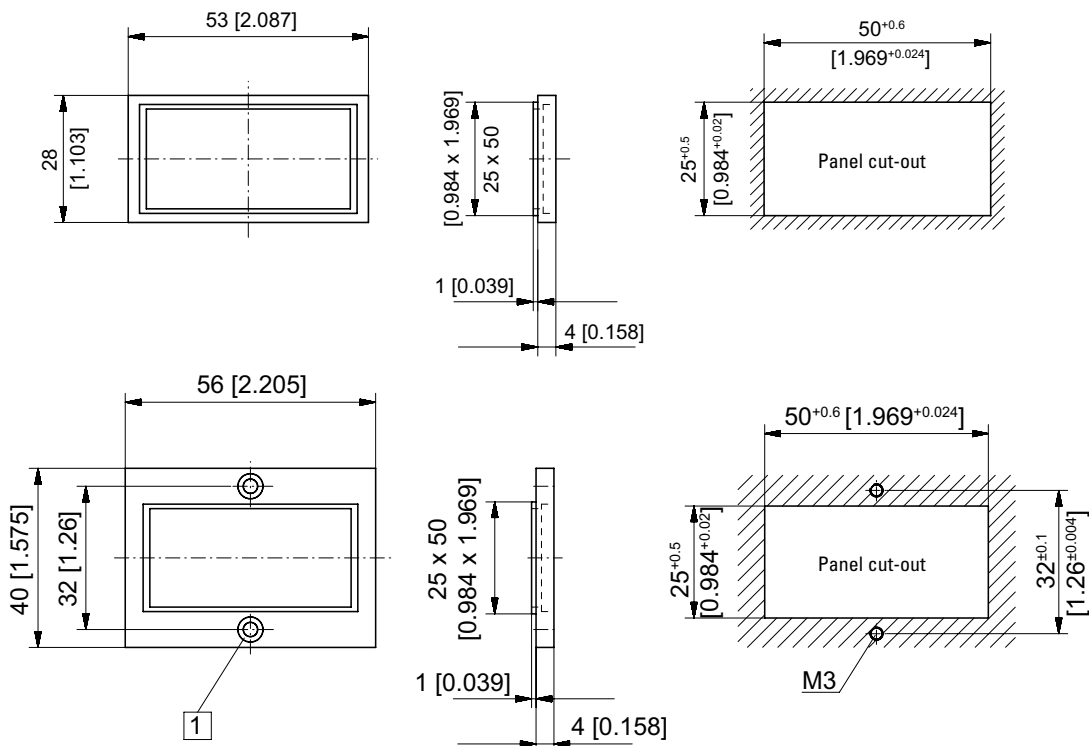

1 Countersinking Af3, DIN 74

Temperature displays

LED temperature displays **For thermocouple inputs J, K and N (DC)** **Codix 532**



Cost-effective temperature display for front panel mount with bright 5-digit LED display for values in °C or °F.

For very accurate temperature measurements using J, K or N thermocouples with permanently stored characteristic curves and selectable cold junction compensation.

Minimum and maximum value detection for temperature monitoring over long periods of time.



DC 10 ... 30V Power supply	J, K, N thermocouples	Menu-driven programming	Galvanic isolation	Temperature range - 20° + 65°	High protection level IP65	Min / Max value detection	DIN front bezel DIN 48 x 24	LED display 5 LED
---	-----------------------	-------------------------	--------------------	----------------------------------	-------------------------------	---------------------------	--------------------------------	----------------------

Product features

- Input ranges: J, K, N thermocouples with external or internal cold junction compensation.
- Compact and cost-effective temperature display.
- Easy programming and operation.
- Modern industrial design.
- 5 measurements / second.

Benefits

- Temperature display in °C or °F.
- MIN/MAX value acquisition and data backup in case of power off.
- Galvanic isolation with protection against incorrect polarity.
- Screw terminal connection: pitch 5 mm.
- Display hold input.

Order no.

Temperature display for J, K and N thermocouples **6.532.012.300** ¹⁾

Delivery specification

- Digital display
- Mounting clip
- Gasket
- Front bezel for screw mounting (T008181) 56 x 40 mm [2.20 x 1.57"], panel cut-out 50 x 25 mm [1.97 x 0.98"]
- Front bezel for clip mounting (T008180) 53 x 28 mm [2.09 x 1.10"], panel cut-out 50 x 25 mm [1.97 x 0.98"]
- 1 set of self-adhesive symbols
- Instruction manual, multilingual

1) Stock types

Product overview Basics
Pulse counters
Preset counters
Hour meters Timers
Frequency displays Tachometers
Position displays
Multifunction devices
Energy meters
Process devices
Temperature devices
Strain-gauge controllers
Accessories Index

Temperature displays

LED temperature displays	For thermocouple inputs J, K and N (DC)	Codix 532
Accessories	Dimensions in mm [inch]	Order no.
Adapter front bezel, 72 x 36 [2.83 x 1.42]	for cut-out 68 x 33 [2.68 x 1.30] to cut-out 45 x 22.2 [1.77 x 0.87], for counters 48 x 24 [1.89 x 0.94], as set	black and silver anodized 162704 Set
Adapter front bezel, 48 x 48 [1.89 x 1.89]	for cut-out 45 x 45 [1.77 x 1.77] to cut-out 45 x 22.2 [1.77 x 0.87], with clip mounting for counters 48 x 24 [1.89 x 0.94]	black T008883
Adapter front bezel, 60 x 50 [2.36 x 1.97]	for cut-out 54 x 29 [2.13 x 1.14] to cut-out 45 x 22.2 [1.77 x 0.87], with screw mounting and gasket for counters 48 x 24 [1.89 x 0.94]	black N003001
Transparent cover, lockable, IP65	for cut-out 54 x 29 [2.13 x 1.14], for screw mounting to front bezel F1B or adapter front bezel N003001, for counters with cut-out 50 x 25 [1.97 x 0.98] or 45 x 22.2 [1.77 x 0.87]	N003002
Sealing cover type K1, IP65	suitable for front bezel 60 x 50 [2.36 x 1.97], for screw mounting of electromech. counters and via adapter front bezel N003001 for counters 48 x 24 [1.89 x 0.94]	G008301
Mounting frame with cut-out 50 x 25 [2.36 x 1.97] via separate adapter also for 45 x 22.2 [1.77 x 0.87]	for snap-on mounting on 35 [1.38] top-hat DIN rail, for counters 53 x 28 [2.09 x 1.10] and via separate adapter (T008180) for counters 48 x 24 [1.89 x 0.94]	chromated G300004

Suitable gaskets, other accessories and installation examples for optional accessories can be found in chapter accessories or in the accessories section under: www.kuebler.com/accessories.

Technical data	
General technical data	
Display	5 digits, red 7 segment LED display; 8 mm [0.32"] high
Display refresh	1 ... 2 times per second
Data backup	EEPROM
Operating temperature	-20°C ... +65°C [-4°F ... +149°F] (non-condensing)
Electrical characteristics	
Power supply	10 ... 30 VDC, galvanically isolated with integrated reverse polarity protection
Current consumption	max. 40 mA
EMC standards	EN 55011 class B EN 61000-6-2, EN 61000-6-3 EN 61326-1
UL approval	file E128604
Mechanical characteristics	
Housing	front panel mount 48x24mm [1.89 x 0.94"] acc. to DIN 43700; RAL 7021, dark grey
Protection	IP65 (front side)
Weight	approx. 50 g [1.76 oz]
Connections	screw terminal, pitch 5.08 mm [2"], 7 pin
Measuring signal inputs	
Measuring rate	5 measurements / second
Input	thermocouple sensor J (Fe-CuNi) K (Ni-CrNi) N (NiCrSi-NiSi) with sensor breakage monitoring
Temperature ranges (according to DIN IEC 584)	J (Fe-CuNi) -210.0°C ... +1200.0°C [-346.0°F ... +2192.0°F] K (Ni-CrNi) -200.0°C ... +1372.0°C [-328.0°F ... +2501.6°F] N (NiCrSi-NiSi) -200.0°C ... +1300.0°C [-328.0°F ... +2370.0°F]
Resolution	0.1°C (0.1°F) or 1°C (1°F)
Linearity error	< 0.4 % for the whole measuring range at an operating temperature of 20°C [68°F]
Temperature drift	0.1 K/K _{Ambient}
Cold junction error	±1°C typ. / ±3°C max.
Control inputs	HIGH 4 ... 30 V DC LOW 0 ... 2 V DC

Temperature displays

LED temperature displays For thermocouple inputs J, K and N (DC) Codix 532

Terminal assignment

1	2	3	4	5	6	7
10 ... 30 V DC	0 V DC GND	Latch input	n.c.	Thermocouple +	n.c.	Thermocouple -

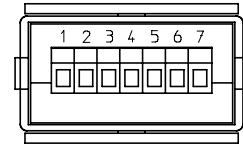

Connection power supply and latch input

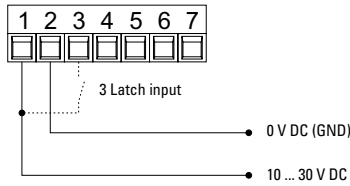

Connection thermocouple sensor

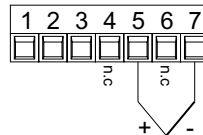

Dimensions

Dimensions in mm [inch]

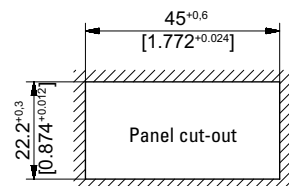
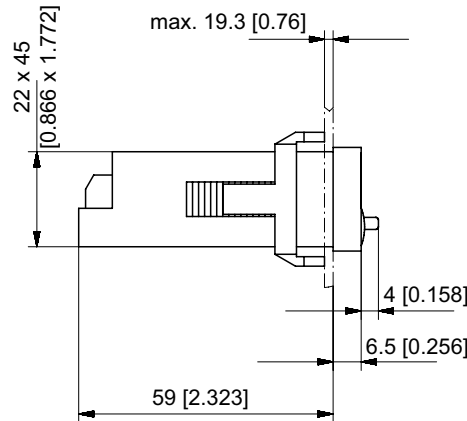
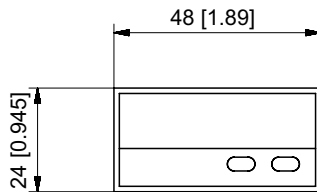

Front bezel

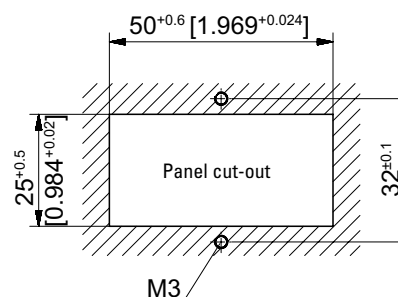
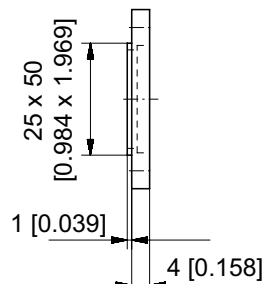
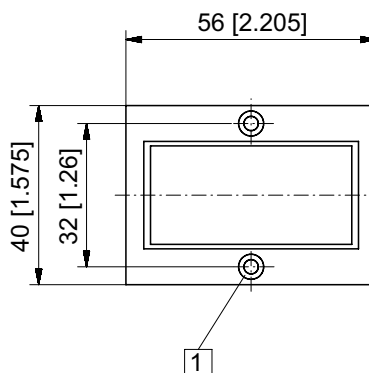
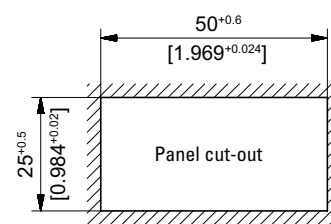
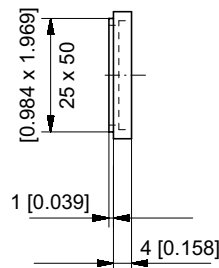
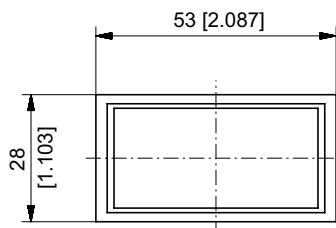

1 Countersinking Af3, DIN 74

Temperature controllers

LED temperature controllers

For temperature sensors with limit value (AC+DC)

Codix 564



The temperature controller Codix 564 displays temperature values in high resolution. In addition it can monitor and control 2 limit values. All current temperature sensors, such as thermocouple types B, E, J, K, N, R, S and T, as well as mV inputs, Pt100 and resistance inputs, can be connected to the device.

These fast displays set new standards when it comes to user friendliness. Their easy-to-read 14-segment LED display, easy-to-understand running help texts and a practical quick-start guide eliminate the need to wade through time-consuming full instruction manuals.

With optional analog output.

DC 10 ... 30 V Power supply	AC 100 ... 240 V Power supply	A..Z* 6 LEDs 14-segment LED display	Prog Menu-driven programming	mV, Ω Display linearization	Temperature input	2, 3, 4 2-, 3-, 4-wire technology	min / max Min / Max value detection	2 2 limit values	AC/DC Galvanic isolation	15 bit Resolution
-20° + 65° Temperature range	DIN 96 x 48 DIN front bezel	Installation in mosaic systems	Operation with gloves	mA, V Analog output optional						

User-friendly

- Practical quick-start guide for setting the parameters and operating the device.
- Help text as running text.
- Easy-to-read 14-segment LED, 6-digit display, 14 mm high.
- Simple programming via 4 keys on the front.
- One front key as well as 2 additional inputs can be programmed for specific applications.
- Characteristic curves for thermocouples and RTD permanently stored.
- MIN/MAX memory function, individually resettable.

Powerful

- Sampling rate of 10 readings per second.
- Customized linearization via 12 control points.
- 2 relay outputs (changeover contacts) for limit monitoring with hysteresis and ON/OFF delay function.
- Analog output for the current measured value, MIN-value, MAX-value.
- Auxiliary sensor power supply with AC version.
- Inputs and outputs galvanically isolated.
- Digital filter (first-order) for smoothing display fluctuations with unstable input signals.

Order code

6.564 . 0 1 0 . X 0 X
a b c d

- a** *Input type*
4 = Temperature signal input ¹⁾
- b** *Outputs*
0 = relays ¹⁾
- c** *Power supply*
0 = 100 ... 240 V AC, ±10 % ¹⁾
3 = 10 ... 30 V DC ¹⁾
- d** *Further outputs (optional)*
0 = none ¹⁾
9 = analog output ¹⁾
(only for DC version)

- Delivery specification:*
- Process device
 - Mounting clip
 - Gasket
 - Instruction manual, multilingual
 - 1 sheet of self-adhesive symbols
 - Quick-start guide

Practical quick-start guide for setting the parameters and operating the device. The guide can be affixed directly to the front of the unit and can be removed and re-applied as required.



1) Stock types.

Temperature controllers

LED temperature controllers For temperature sensors with limit value (AC+DC) Codix 564

Accessories	Dimensions in mm [inch]	Order no.
Mounting frame with cut-out 92 x 45 [3.62 x 1.77]	for snap-on mounting on 35 [1.38] top-hat DIN rail, for counters 96 x 48 [3.74 x 1.89]	grey G300005

Suitable gaskets as well as further accessories can be found in the accessories section or in the accessories area of our website at: www.kuebler.com/accessories.

Technical data

General technical data	
Display	6-digit, 14 segment LED
Digit height	14 mm [0.55"]
Display range	-199999 ... 999999, with leading zero blanking
Data retention	> 10 years, EEPROM
Operation	5 keys
Operating temperature	-20°C ... +65°C [-4°F ... +149°F] (non-condensing)
Storage temperature	-25°C ... +75°C [-13°F ... +167°F]
Relative humidity (non-condensing)	R.H. 93 % at +40°C [+104°F]
Altitude	up to 2000 m [6562']

Electrical characteristics	
Power supply	AC supply 100 ... 240 V AC / max. 9 VA, 50 / 60 Hz, tolerance ±10 % ext. fuse protection: T 0.1 A
	DC supply 10 ... 30 V DC / max. 3.8 W with galvanic isolation and reverse polarity protection ext. fuse protection: T 0.4 A
Mains hum suppression (programmable)	50 Hz or 60 Hz
Sensor power supply	AC supply 24 V DC ±15 %, 30 mA
EMC standard	EN 55011 class B EN 61000-6-2, EN 61000-6-3 with shielded signal and control cables
Device safety	designed to EN 61010 part 1 protection class 2 (front side) application area pollution level 2 overvoltage category II
UL approval	file E128604

Measuring signal inputs	
Sampling rate	10 readings/sec
Temperature drift	< 100 ppm/K _{Ambient}
Input Thermocouple	
thermocouple:	range: accuracy at 23°C [73.4°F]:
type B	+250°C ... 1820°C [+482°F ... 3308°F] typ. 1.0°C, max. 2.0°C
E	-200°C ... +1000°C [-328°F ... +1832°F] typ. 0.2°C, max. 0.5°C
J	-210°C ... +1200°C [-346°F ... +2192°F] typ. 0.2°C, max. 0.5°C
K	-200°C ... 499.9°C [-328°F ... +931.82°F] -500°C ... +1372°C [-868°F ... 2502°F] typ. 0.6°C, max. 1.0°C
N	-200°C ... +1300°C [-328°F ... 2372°F] typ. 0.3°C, max. 0.7°C
R	-50°C ... +1768°C [-58°F ... +3214°F] typ. 1.0°C, max. 2.0°C
S	-50°C ... +1768°C [-58°F ... +3214°F] typ. 1.0°C, max. 2.0°C
T	-200°C ... +400°C [-328°F ... +752°F] typ. 0.2°C, max. 0.5°C
Resolution J, K, T, E, N	1 or 0.1°C/°F
Resolution S, R, B	1°C/°F
Reference point	internal or external constant
Reference point accuracy	≤ ±1°C
Input mV	
Measuring range	±105 mV (resolution ±15 bit)
Measuring accuracy at 23°C [73.4°F] (% of range)	typ. 0.02 / max. ≤ 0.05
Input resistance	> 2 MΩ
Input Pt100	
Measuring range	-200°C ... +850°C [-328°F ... +1562°F]
Resolution	1 or 0.1°C / °F
Measuring accuracy at 23°C [73.4°F]	typ. 0.3°C, max. ≤ 0.6°C
Measuring current	200 µA
Connection	2-, 3-, 4-wire
Lead wire resistance	max. 25 Ω per wire
Input 500 Ω	
Measuring range	0 ... 525 Ω (resolution ±15 bit)
Measuring accuracy at 23°C [73.4°F]	typ. 0.1 Ω, max. ≤ 0.2 Ω
Measuring current	200 µA
Connection	2-, 3-, 4-wire
Lead wire resistance	max. 25 Ω per wire

Temperature controllers

LED temperature controllers For temperature sensors with limit value (AC+DC) Codix 564

Mechanical characteristics	
Housing	Panel mount housing to DIN 43700 RAL 7021
Dimensions	96 x 48 x 102 mm [3.78 x 1.89 x 4.02"]
Panel cut-out	92 +0.8 x 45 +0.6 mm [3.62 +0.032 x 1.77 +0.024"]
Installation depth	approx. 92 mm [3.62"] incl. terminals
Weight	approx. 180 g [6.34 oz] with analog output 200 g [7.06 oz]
Protection	IP65 (front side)
Housing material	Polycarbonate UL94 V-2
Vibration resistance acc. to EN 60068-2-6	10 - 55 Hz / 1 mm / XYZ 30 min in each direction
Shock resistance acc. to EN 60068-2-27	100 G / 2 ms / XYZ 3 times in each direction
acc. to EN 60068-2-29	10 G / 6 ms / XYZ 2000 times in each direction
Connections	
Power supply and outputs	Plug-in screw terminal, 8-pin, RM 5.00, core \varnothing max. 2.5 mm ² [AWG 13]
Signal and control inputs	Plug-in screw terminal, 9-pin, RM 3.50, core \varnothing max. 1.5 mm ² [AWG 15]

Alarm outputs	
Relays	changeover contacts
Switching voltage	max. 250 V AC / 125 V DC min. 5 V AC / 5 V DC
Switching current	max. 5 A AC / 5 A DC min. 10 mA DC
Switching capacity	max. 1250 VA / 150 W
Pull-in time	approx. 10 ms

Analog output (optional - only for DC version)	
Output ranges	0 (4) ... 20 mA / 0 (2) ... 10 V
Load	current output $\leq 500 \Omega$ voltage output $\geq 2000 \Omega$
Resolution	15 bit
Update time (basic device measuring rate)	100 ms
Temperature drift	$\leq 100 \text{ ppm/K}_{\text{Ambient}}$
Accuracy	$\pm 0.1 \%$ of the output range high value
Output ripple	$\leq 10 \text{ mV}$
Isolation voltage	500 V AC for 1 minute or 1 kV DC for 1 second

Control inputs MPI 1 / MPI 2	
Quantity	2 optocouplers
Function	programmable
Switching levels	LOW $< 2 \text{ V}$ HIGH $> 4 \text{ V}$ (max. 30 V)
Pulse length	$> 100 \text{ ms}$

Terminal assignment

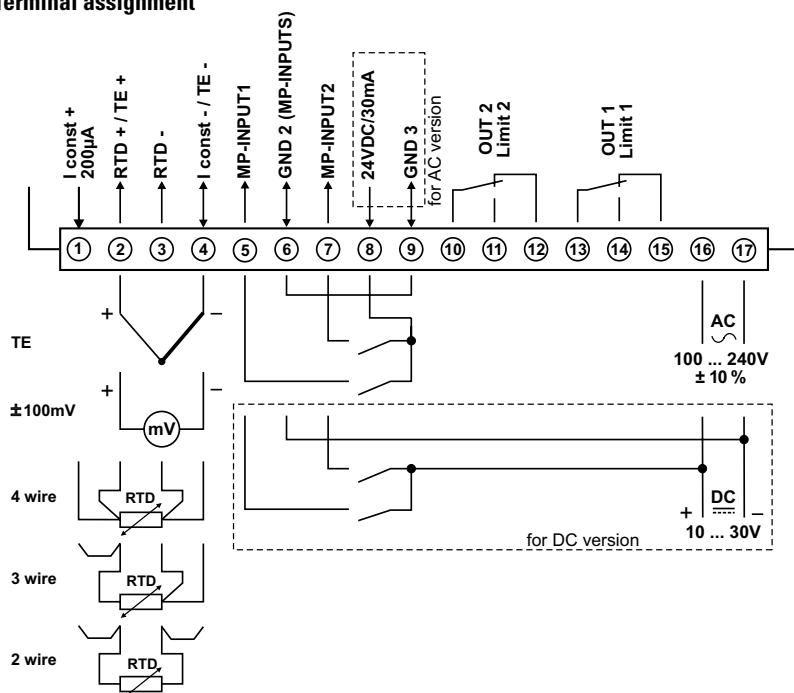

Rear side view

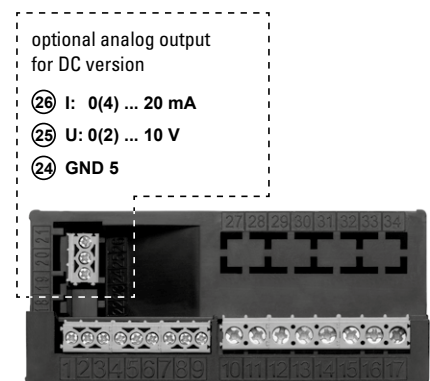

Product overview Basics
Pulse counters
Preset counters
Hour meters Timers
Frequency displays Tachometers
Position displays
Multifunction devices
Energy meters
Process devices
Temperature devices
Strain-gauge controllers
Accessories Index

Temperature controllers

LED temperature controllers For temperature sensors with limit value (AC+DC) Codix 564

Block diagram

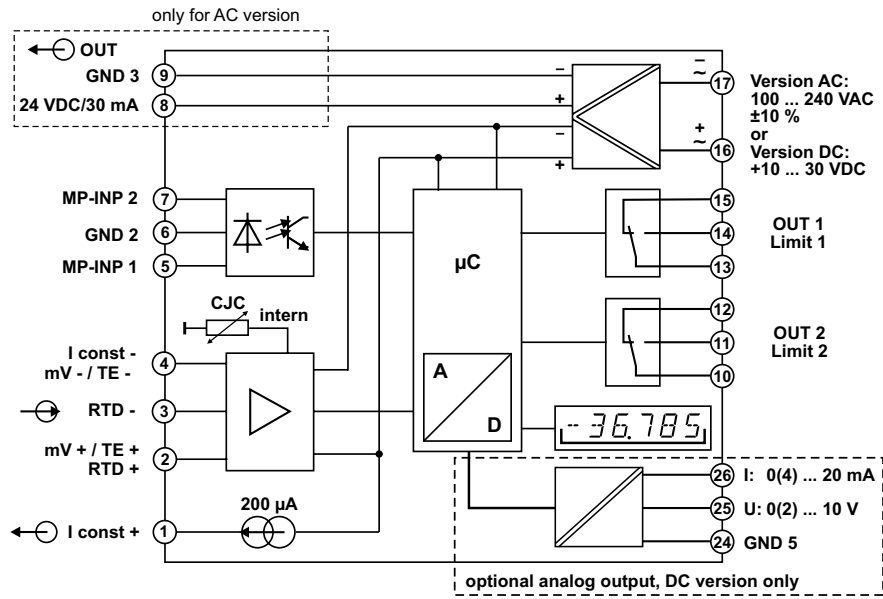

Dimensions

Dimensions in mm [inch]

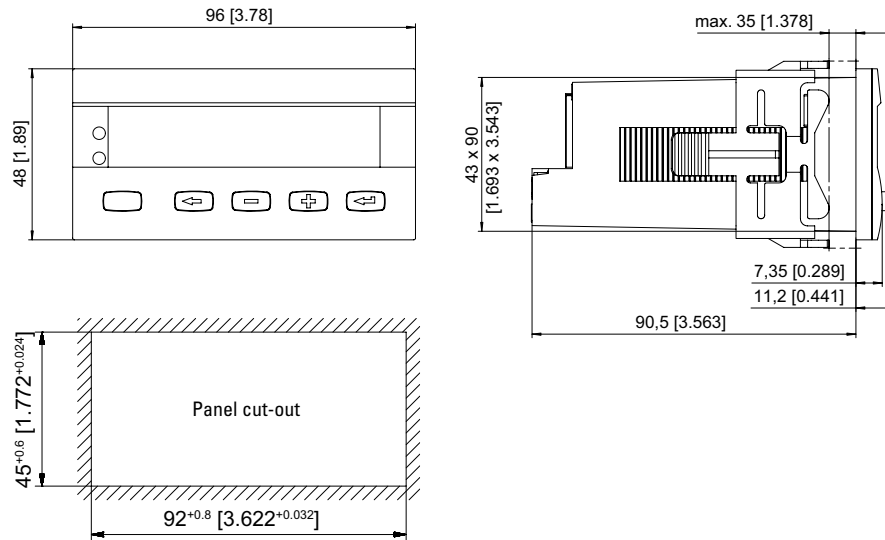

Product overview
Basics

Pulse counters

Preset counters

Hour meters
Timers

Frequency displays
Tachometers

Position displays

Multifunction
devices

Energy meters

Process devices

Temperature
devices

Strain-gauge
controllers

Accessories
Index



Strain-gauge controllers

Strain-gauge controllers		Type	Page
LED strain-gauge controllers	For strain-gauge inputs	Codix 566	300

Product overview
Basics

Pulse counters

Preset counters

Hour meters
Timers

Frequency displays
Tachometers

Position displays

Multifunction
devices

Energy meters

Process devices

Temperature
devices

Strain-gauge
controllers

Accessories
Index

Strain-gauge controllers

LED strain-gauge controllers

For strain-gauge inputs (AC+DC)

Codix 566



The process controller Codix 566 with totalizer function displays measured values from all common strain-gauge inputs in high resolution. In addition it can monitor and control 2 limit values.

These fast displays set new standards when it comes to user friendliness. Their easy-to-read 14-segment LED display, easy-to-understand running help texts and a practical quick-start guide eliminate the need to wade through time-consuming full instruction manuals.

With optional analog output.

DC 10 ... 30 V Power supply	AC 100 ... 240 V Power supply	A.Z* 6 LEDs 14-segment LED display	Prog Menu-driven programming	mV Display linearization	Tara Tare function	Σ Totalizer function	Strain-gauge input	min / max Min / Max value detection	2 2 limit values	AC/DC Galvanic isolation
15 bit Resolution	-20° + 65° Temperature range	DIN 96 x 48 DIN front bezel	Installation in mosaic systems	Operation with gloves	Analog output optional					

User-friendly

- Practical quick-start guide for setting the parameters and operating the device.
- Help text as running text.
- Easy-to-read 14-segment LED, 6-digit display, 14 mm high.
- Simple programming via 4 keys on the front.
- One front key as well as 2 additional inputs can be programmed for specific applications.
- Customer-specific characteristic (linearization) curve via 12 control points for all measurement signal inputs.
- MIN/MAX memory function, individually resettable.

Powerful

- Sampling rate of 10 readings per second.
- Application-specific characteristic curves via 12 measurement points.
- Manual totalizer function for totalizing the measured values. Can be reset separately.
- 2 relay outputs (changeover contacts) for limit monitoring with hysteresis and ON/OFF delay function for current measured or totalizer values.
- Analog output for the current measured value, MIN-value, MAX-value or totalizer value.
- Auxiliary sensor power supply 10 V DC / 30 mA for powering 350 Ω bridges.
- Inputs and outputs galvanically isolated.
- Digital filter (first-order) for smoothing display fluctuation with unstable input signals.
- Tare function.

Order code

6.56 **a** . 0 **b** 1 0 . **c** **d** X 0 X

a Input type
6 = Strain-gauge inputs ¹⁾

b Outputs
0 = relays ¹⁾

c Power supply
0 = 100 ... 240 V AC, ±10 % ¹⁾
3 = 10 ... 30 V DC ¹⁾

d Further outputs (optional)
0 = none ¹⁾
9 = analog output ¹⁾ (only for DC version)

Delivery specification:

- Process device
- Mounting clip
- Gasket
- Instruction manual, multilingual
- 1 sheet of self-adhesive symbols
- Quick-start guide

Practical quick-start guide for setting the parameters and operating the device.

The guide can be affixed directly to the front of the unit and can be removed and re-applied as required.



1) Stock types.

Strain-gauge controllers

LED strain-gauge controllers For strain-gauge inputs (AC+DC) Codix 566

Accessories	Dimensions in mm [inch]	Order no.
Mounting frame with cut-out 92 x 45 [3.62 x 1.77]	for snap-on mounting on 35 [1.38] top-hat DIN rail, for counters 96 x 48 [3.74 x 1.89]	grey G300005

Suitable gaskets as well as further accessories can be found in the accessories section or in the accessories area of our website at: www.kuebler.com/accessories.

Technical data

General technical data	
Display	6-digit, 14 segment LED
Digit height	14 mm [0.55"]
Display range	-199999 ... 999999, with leading zero blanking
Data retention	> 10 years, EEPROM
Operation	5 keys
Operating temperature	-20°C ... +65°C [-4°F ... +149°F] (non-condensing)
Storage temperature	-25°C ... +75°C [-13°F ... +167°F]
Relative humidity (non-condensing)	R.H. 93 % at +40°C [+104°F]
Altitude	up to 2000 m [6562']

Electrical characteristics	
Power supply	AC supply 100 ... 240 V AC / max. 9 VA 50 / 60 Hz, tolerance ±10 % ext. fuse protection: T 0.1 A
	DC supply 10 ... 30 V DC / max. 3.8 W with galvanic isolation and reverse polarity protection ext. fuse protection: T 0.4 A
Mains hum suppression	50 Hz or 60 Hz programmable
Sensor power supply	AC supply 24 V DC ±15 %, 30 mA
	DC supply 10 V DC ±1 %, 30 mA
EMC standard	EN 55011 class B EN 61000-6-2, EN 61000-6-3 with shielded signal and control cables
Device safety	designed to EN 61010 part 1 protection class 2 (front side) application area pollution level 2 overvoltage category II
UL approval	file E128604

Mechanical characteristics	
Housing	Panel mount housing to DIN 43700 RAL 7021
Dimensions	96 x 48 x 102 mm [3.78 x 1.89 x 4.02"]
Panel cut-out	92 +0.8 x 45 +0.6 mm [3.62 +0.032 x 1.77 +0.024"]
Installation depth	approx. 92 mm [3.62"] incl. terminals
Weight	approx. 180 g [6.34 oz] with analog output 200 g [7.06 oz]
Protection	IP65 (front side)
Housing material	Polycarbonate UL94 V-2
Vibration resistance acc. to EN 60068-2-6	10 - 55 Hz / 1 mm / XYZ 30 min in each direction
Shock resistance acc. to EN 60068-2-27	100 G / 2 ms / XYZ
	3 times in each direction acc. to EN 60068-2-29 10 G / 6 ms / XYZ 2000 times in each direction
Connections	
Power supply and outputs	Plug-in screw terminal, 8-pin, RM 5.00, core ø max. 2.5 mm² [AWG 13]
Signal and control inputs	Plug-in screw terminal, 9-pin, RM 3.50, core ø max. 1.5 mm² [AWG 15]

Control inputs MPI 1 / MPI 2	
Quantity	2 optocouplers
Function	programmable
Switching levels	LOW < 2 V
	HIGH > 4 V (max. 30 V)
Pulse length	> 100 ms

Measuring signal inputs	
Sampling rate	10 readings/sec
Input resistance	1 MΩ
Max. measuring signal range	approx. ±35 mV
Max. voltage	±10 V

Sensitivity ranges: 3.3 – 3.0 – 2.0 mV / V	
Resolution	±15 bit
Measuring accuracy at 23°C (% of range)	typ. 0.05 % / max. ≤ 0.1 %
Temperature drift	< 100 ppm/K _{Ambient}

Sensitivity ranges: 1.5 – 1.0 mV / V	
Resolution	±14 bit
Measuring accuracy at 23°C (% of range)	typ. 0.1 % / max. ≤ 0.2 %
Temperature drift	< 100 ppm/K _{Ambient}

Strain-gauge controllers

LED strain-gauge controllers For strain-gauge inputs (AC+DC) Codix 566

Analog output (optional - only for DC version)	
Output ranges	0 (4) ... 20 mA / 0 (2) ... 10 V
Load	current output $\leq 500 \Omega$ voltage output $\geq 2000 \Omega$
Resolution	15 bit
Update time (basic device measuring rate)	100 ms
Temperature drift	$\leq 100 \text{ ppm/K}_{\text{Ambient}}$
Accuracy	$\pm 0.1 \%$ of the output range high value
Output ripple	$\leq 10 \text{ mV}$
Isolation voltage	500 V AC for 1 minute or 1 kV DC for 1 second

Alarm outputs	
Relays	changeover contacts
Switching voltage	max. 250 V AC / 125 V DC min. 5 V AC / 5 V DC
Switching current	max. 5 A AC / 5 A DC min. 10 mA DC
Switching capacity	max. 1250 VA / 150 W
Pull-in time	approx. 10 ms

Terminal assignment

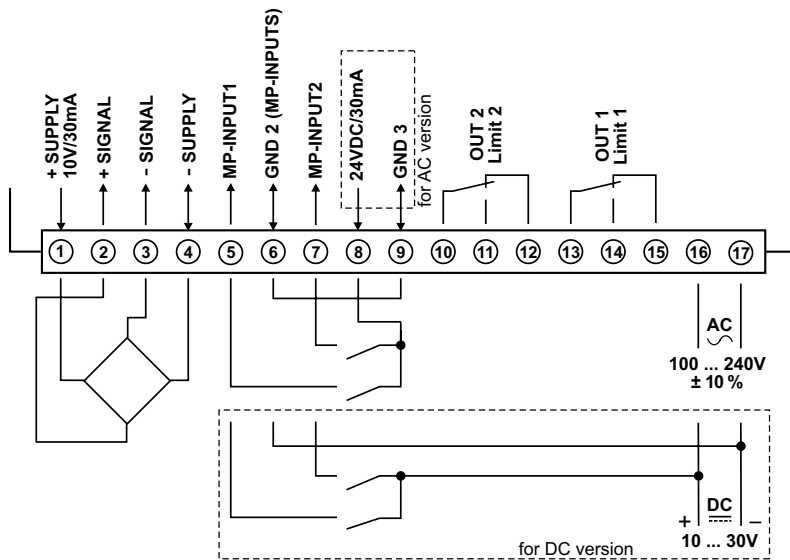

Rear side view

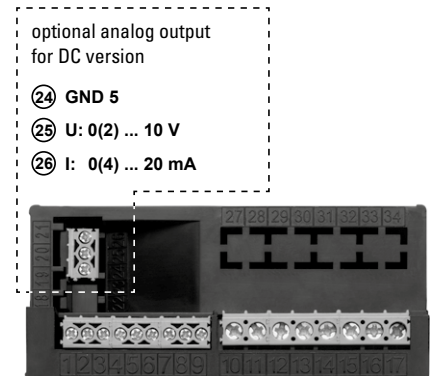

Strain-gauge controllers

LED strain-gauge controllers For strain-gauge inputs (AC+DC) Codix 566

Block diagram

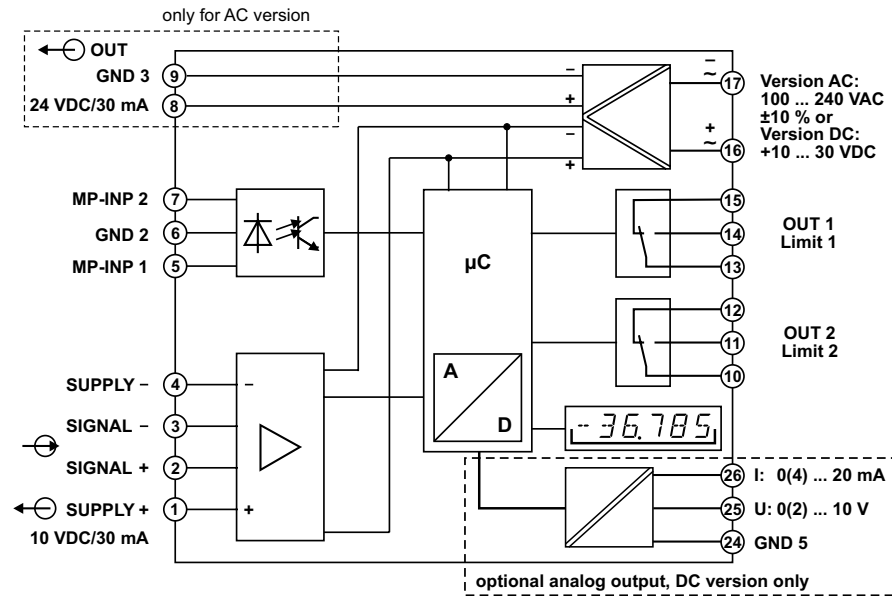

Dimensions

Dimensions in mm [inch]

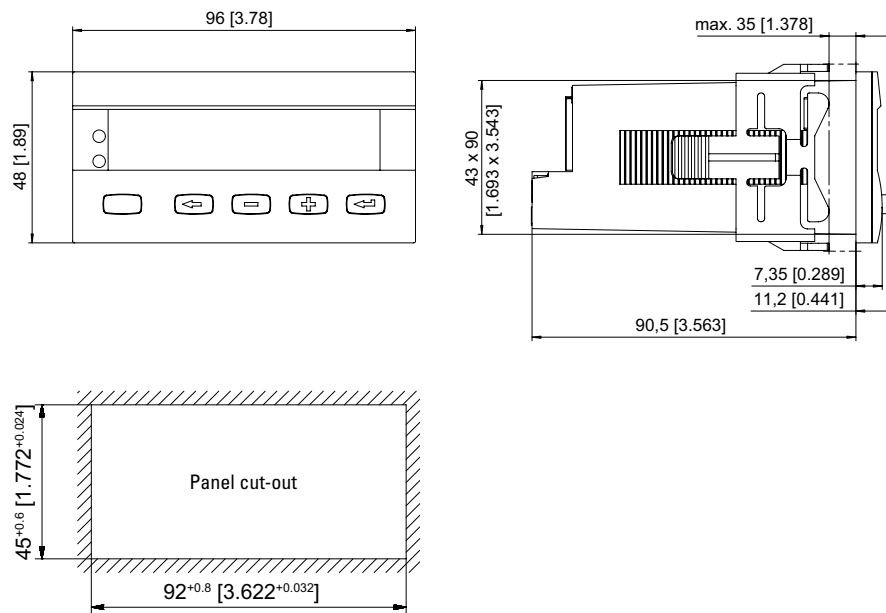



Product overview
Basics

Pulse counters

Preset counters

Hour meters
Timers

Frequency displays
Tachometers

Position displays

Multifunction
devices

Energy meters

Process devices

Temperature
devices

Strain-gauge
controllers

Accessories
Index

Accessories / Index

Accessories			Page	
Overview	Adapter front bezel		306	Product overview Basics
	Sealing cover		307	
	Transparent cover		307	Pulse counters
	Front bezel		308	
	Socket boxes		308	
	Mounting examples		309	
	Mounting frame		310	Preset counters
	DIN rail mount		310	
	Enclosure blind		311	
	Other accessories		311	
Details	Adapter front bezel		312	Hour meters Timers
	Sealing cover		315	
	Transparent cover		316	Frequency displays Tachometers
	Front bezel		318	
	Socket boxes		319	
	Mounting frame		321	
	DIN rail mount		322	Position displays
	Enclosure blind		323	
	Other accessories		324	
	Mounting examples for optional accessories	For counters 48 x 24 mm [1.89 x 0.94"]	Codix 13X / Codix 14X / Codix 52X / Codix 53X W15.51 / W16.50 / W17.50 / H37 / H37.5	
For counters 48 x 48 mm [1.89 x 1.89"]		Codix 901 / Codix 907 / Codix 908 / Codix 923 / Codix 924 H 57 / HC 77 / HW 66	327	
For counters 50 x 25 mm [1.97 x 0.98"]		B16.01 / B18.00 / HB26.01.3 / HB27.00.3 B16.3X / B18.30	328	Multifunction devices
For 2 counters 50 x 25 mm [1.97 x 0.98"]		B16.01 / B18.00 / HB26.01.3 / HB27.00.3 (any combination of 2 counters)	329	
For counters 50 x 50 mm [1.97 x 1.97"]		BVa 15.01 / BVa 15.31	330	
Gaskets			331	Energy meters
Index			Page	
List of order numbers			332	Process devices
Addresses			336	Temperature devices
				Strain-gauge controllers
				Accessories Index

Overview

Adapter front bezel							counter 48 x 24 mm [1.89 x 0.94"]						counter 48 x 48 mm [1.89 x 1.89"]			counter 96 x 48 mm [3.78 x 1.89"]		
							Codix 13x	Codix 14x	Codix 52x	Codix 53x	W 1x.5 H 37, H 37.5	Codix 90x, 92x	901	H 57, HC 77, HW 66	Codix 54x	Codix 56x	Codix 57x	
Figure	Size	for cut-out	to cut-out	Order no.	Details s. page													
	53 x 28 mm [2.09 x 1.10"]	50 x 25 mm [1.97 x 0.98"]	45 x 22.2 mm [1.77 x 0.94"]	grey black anthracite	T008164 T008165 T008180	312	X	X	X	X	X	X						
	56 x 40 mm [2.20 x 1.57"]	50 x 25 mm [1.97 x 0.98"]	45 x 22.2 mm [1.77 x 0.94"]	black anthracite	T008161 T008181	312	X	X	X	X	X	X						
	72 x 36 mm [2.83 x 1.42"]	68 x 33 mm [2.68 x 1.30"]	45 x 22.2 mm [1.77 x 0.94"]	black and silver anodised as set	162704 Set	312	X	X	X	X	X	X						
	60 x 50 mm [2.36 x 1.97"]	54 x 29 mm [2.13 x 1.14"]	45 x 22.2 mm [1.77 x 0.94"]	black	N003001	313	X	X	X	X	X	X						
	48 x 48 mm [1.89 x 1.89"]	45 x 45 mm [1.77 x 1.77"]	45 x 22.2 mm [1.77 x 0.94"]	black	T008883	313	X	X	X	X	X	X						
	55 x 55 mm [2.16 x 2.16"]	50 x 50 mm [1.97 x 1.97"] or ø 50.5 mm [1.99"]	45 x 45 mm [1.77 x 1.77"]	grey black	T008170 T008171	313							X					
	55 x 55 mm [2.16 x 2.16"]	50 x 50 mm [1.97 x 1.97"]	45 x 45 mm [1.77 x 1.77"]	black	T008853	313							X	X	X			
	60 x 75 mm [2.36 x 2.95"]	50 x 50 mm [1.97 x 1.97"]	45 x 45 mm [1.77 x 1.77"]	black	T008860	314							X	X	X			
	72 x 72 mm [2.83 x 2.83"]	68 x 68 mm [2.68 x 2.68"]	45 x 45 mm [1.77 x 1.77"]	grey black mating clip	T008176 T008177 T009420	314							X	X	X			
	ø 72 mm [2.83"]	ø 60 mm [2.36"]	45 x 45 mm [1.77 x 1.77"]	black	N510226	314							X	X	X			

 Product overview
Basics

Pulse counters

Preset counters

 Hour meters
Timers

 Frequency displays
Tachometers

Position displays

 Multifunction
devices

Energy meters

Process devices



 Temperature
devices

 Strain-gauge
controllers



 Accessories
Index

Accessories

Overview

Sealing cover						for electromechanical counters						counter 48 x 24 mm [1.89 x 0.94"] ¹⁾		counter 48 x 48 mm [1.89 x 1.89"] ²⁾		
Figure	Type	Description	Order no.	Details s. page	B 1x.3x	HB 2x.3x	BVa 15.3x	HVa 15.3x	MVs 16.3x	MVs 13.1x	Codix 13x, 14x	Codix 52x, 53x	W 1x.5	H 37, H 37.5	Codix 90x, 92x	901
	K1	for front bezel 60 x 50 mm [2.36 x 1.97"]	transparent / grey transparent / black	G008300 G008301	315	X	X				X	X	X	X		
	K2	for front bezel 75 x 60 mm [2.95x 2.36"]	transparent / grey transparent / black	G008302 G008303	315			X	X	X					X	X
	KV3	for front bezel 39 x 68 mm [1.54 x 2.68"]	transparent / grey transparent / black	G008310 G008311	315					X						

1) via adapter front bezel N003001
2) via adapter front bezel T008860

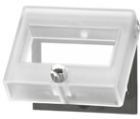
Transparent cover						for electromechanical counters						counter 48 x 24 mm [1.89 x 0.94"] ³⁾		counter 48 x 48 mm [1.89 x 1.89"]			
Figure	Type	Description	Order no.	Details s. page	B 1x.3x, HB 2x.3x	B 1x.0x, HB 2x.0x					Codix 13x, 14x	Codix 52x, 53x	W 1x.5	H 37, H 37.5	Codix 90x, 92x	901	H 57, HC 77, HW 66
	2 Dv (mounted on bezel)	lockable cover, IP65 for cut-out 50 x 50 mm [1.97 x 1.97"]	transparent / black	G008143	316										X	X	X
	2 Dvs (mounted on bezel)	key lockable cover, IP65 for cut-out 50 x 50 mm [1.97 x 1.97"]	transparent / black	G008153	316										X	X	X
	1 Dv (mounted on bezel)	lockable cover, IP65 for cut-out 54 x 29 mm [2.13 x 1.14"]	transparent / black	N003002	317	X	X ⁴⁾				X	X	X	X			



4) with front bezel FIB

3) with adapter front bezel N003001

Product overview
Basics
Pulse counters
Preset counters
Hour meters
Timers
Frequency displays
Tachometers
Position displays
Multifunction devices
Energy meters
Process devices
Temperature devices
Strain-gauge controllers
Accessories
Index

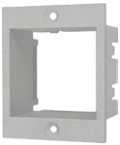
Overview

Front bezel						for electromechanical counters		
Figure	Type	Description	Order no.	Details s. page	B 1x.0x, HB 2x.0x (in socket box type 945.2)	BVa 15.0x (in socket box type 946.1)	2 x B- or HB counters (in 2 x socket box type 945.2)	
	F1B	for cut-out 54 x 49 mm [2.13 x 1.93"]	beige black	G007501 G007502	318	X		
	F2B	for cut-out 54 x 54 mm [2.13 x 2.13"]	beige black	G007503 G007504	318		X	X

Socket boxes						for electromechanical counters			
Figure	Type	Description	Order no.	Details s. page	B 1x.0x, HB 2x.0x	MVs 16.0	BVa 15, HVa 15		
	945.2	for plug-in connection in front bezel F1B	black	G008434	319	X			
	926.1	for plug-in connection of MVs 16	transparent	G008433	320		X		
	946.1	for plug-in connection in front bezel F2B	black	G008439	320		X		

Product overview
Basics

Pulse counters

Preset counters

Hour meters
Timers

Frequency displays
Tachometers

Position displays

Multifunction
devices

Energy meters

Process devices

Temperature
devices

Strain-gauge
controllers



Accessories
Index

Overview



Mounting examples for optional accessories							
Figure	s. page	for counters 48 x 24 mm [1.89 x 0.94"] in cut-out 50 x 25 mm [1.97 x 0.98"] W, H37, Codix 13x / 14x / 52x / 53x	for counters 48 x 48 mm [1.89 x 1.89"] in cut-out 50 x 50 mm [1.97 x 1.97"] Codix 90x / 92x, H 57, HC 77, HW 66	for counters 50 x 25 mm [1.97 x 0.98"] in cut-out 54 x 29 mm [2.13 x 1.14"] B and HB counters	for counter combinations of 2 counters 50 x 25 mm [1.97 x 0.98"] in cut-out 54 x 54 mm [2.13 x 2.13"] B and HB counters	for counters 50 x 50 mm [1.97 x 1.97"] in cut-out 54 x 54 mm [2.13 x 2.13"] BVA and HVa counters	
	326	X					
	327		X				
	328			X			
	329				X		
	330					X	

Product overview
Basics
Pulse counters
Preset counters
Hour meters
Timers
Frequency displays
Tachometers
Position displays
Multifunction devices
Energy meters
Process devices
Temperature devices
Strain-gauge controllers

Overview

Mounting frame						for electrom. counters			counter 48 x 24 mm [1.89 x 0.94"] ¹⁾			counter 48 x 48 mm [1.89 x 1.89"]			c. 96 x 48 mm [3.78 x 1.89"]	
Figure	Cut-out	Description	Order no.	Details s. page	BVa 15.21, HVa 15.21	MVs 16.2x	B 1x.2x, HB 2x.2x	Codix 13x, 14x	Codix 52x, 53x	W 1x.5	H 37, H 37.5	Codix 90x, 92x	901	H 57, HC 77, HW 66	Codix 54x, 55x	Codix 56x, 57x
	92 x 45 mm [3.62 x 1.77"]	For snap-on mounting on 35 mm [1.38"] top-hat DIN rail	grey	G300005	321										X	X
	50 x 50 mm [1.97 x 1.97"] (45 x 45 mm [1.77 x 1.77"] via supplied adapter)	For snap-on mounting on 35 mm [1.38"] top-hat DIN rail	chromated	G300003	321	X	X					X	X	X		
	50 x 25 mm [1.97 x 0.98"] (45 x 22.2 mm [1.77 x 0.87"] via separate adapter)	For snap-on mounting on 35 mm [1.38"] top-hat DIN rail	chromated	G300004	321			X	X	X	X					





1) via adapter T008180

DIN rail mount						for electrom. counters		
Figure	Type	Description	Order no.	Details s. page	B and HB counter	2 x B and HB counter	BVa and HVa counter	
	SR 1	For snap-on mounting on on 35 mm [1.38"] top-hat DIN rail	G300000	322	X			
	SR 2	For snap-on mounting on on 35 mm [1.38"] top-hat DIN rail	G300001	322		X		
	SR 3	For snap-on mounting on on 35 mm [1.38"] top-hat DIN rail	G300002	322			X	

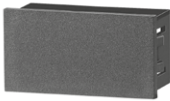
Accessories

Overview

Enclosure blind						counter 48 x 24 mm [1.89 x 0.94"]				counter 53 x 28 mm [2.09 x 1.10"]	
Figure	Size	Cut-out	Order no.	Details s. page		Codix 13x, 14x	Codix 52x, 53x	W 1x.5	H 37, H 37.5	B and HB counters	
	48 x 24 mm [1.89 x 0.94"]	for cut-out 45 x 22.2 mm [1.77 x 0.87"] and 50 x 25 mm [1.97 x 0.98"]	anthracite G003836	323		X	X	X	X		
	53 x 28 mm [2.09 x 1.10"]	for cut-out 50 x 25 mm [1.97 x 0.98"]	black T005753	323						X	

Other accessories					for counters			
Figure	Description	Order no.	Details s. page		H 37	H 57	HR 76.2	HR 47
	Terminal cover type KA 37	transparent T051687	324		X			
	Base-mount socket	black G008040	324			X		
	Mounting support	black N510199	324				X	X
	Adapter and anti-vibration set	black 255319	325					X

 Product overview
Basics

Pulse counters

Preset counters

 Hour meters
Timers

 Frequency displays
Tachometers

Position displays

 Multifunction
devices

Energy meters

Process devices

 Temperature
devices





 Strain-gauge
controllers

 Accessories
Index

Accessories

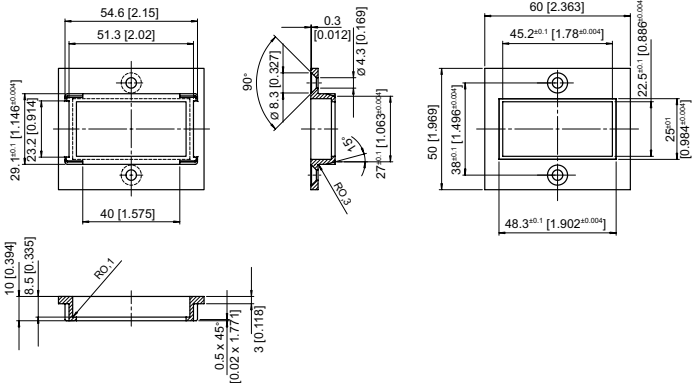
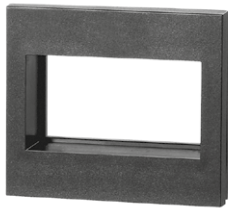
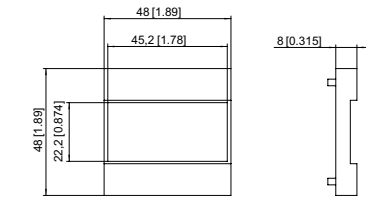
Adapter front bezel		Details		Order no.	Product overview Basics
Dimensions / Details		Dimensions in mm [inch]			
Adapter front bezel, 53 x 28 mm [2.09 x 1.10"] with clip mounting for counters 48 x 24 mm [1.89 x 0.94"]	<i>cut-out:</i> for cut-out 50 x 25 mm [1.97 x 0.98"] to cut-out 45 x 22.2 mm [1.77 x 0.94"]	<i>suitable for:</i> Codix 13x, 14x, 52x, 53x, W 15.5, W 16.5, W 17.5, H 37, H 37.5	grey black anthracite	T008164 T008165 T008180	Pulse counters Preset counters
Adapter front bezel, 56 x 40 mm [2.20 x 1.57"] with screw mounting for counters 48 x 24 mm [1.89 x 0.94"]	<i>cut-out:</i> for cut-out 50 x 25 mm [1.97 x 0.98"] to cut-out 45 x 22.2 mm [1.77 x 0.94"]	<i>suitable for:</i> Codix 13x, 14x, 52x, 53x, W 15.5, W 16.5, W 17.5, H 37, H 37.5	black anthracite	T008161 T008181	Hour meters Timers Frequency displays Tachometers Position displays
Adapter front bezel, 72 x 36 mm [2.83 x 1.42"] for counters 48 x 24 mm [1.89 x 0.94"]	<i>cut-out:</i> for cut-out 68 x 33 mm [2.68 x 1.30"] to cut-out 45 x 22.2 mm [1.77 x 0.94"]	<i>suitable for:</i> Codix 13x, 14x, 52x, 53x, W 15.5, W 16.5, W 17.5, H 37, H 37.5	black and silver anodised as set	162704 Set	Multifunction devices Energy meters Process devices Temperature devices Strain-gauge controllers
1 Front bezel (1 x black, 1 x silver anodised)	2 Bezel adapter				

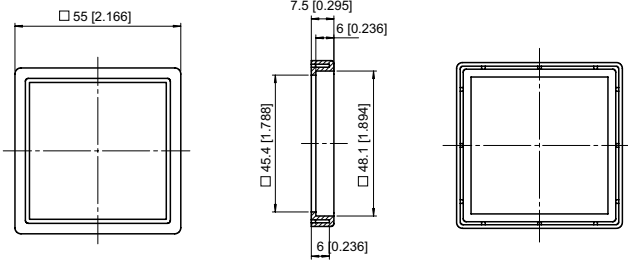
Accessories

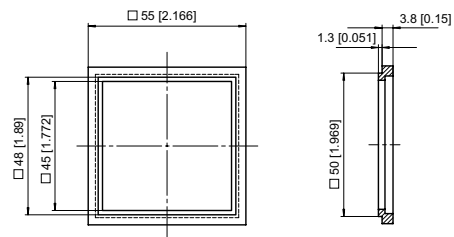
Adapter front bezel		Details		Order no.	Product overview
Dimensions / Details		Dimensions in mm [inch]			Basics
Adapter front bezel, 60 x 50 mm [2.36 x 1.97"] with screw mounting, incl. gasket for counters 48 x 24 mm [1.89 x 0.94"]	cut-out: for cut-out 54 x 29 mm [2.13 x 1.14"] to cut-out 45 x 22.2 mm [1.77 x 0.94"]	suitable for: Codix 13x, 14x, 52x, 53x, W 15.5, W 16.5, W 17.5, H 37, H 37.5	black	N003001	Pulse counters Preset counters
					Hour meters Timers
Adapter front bezel, 48 x 48 mm [1.89 x 1.89"] with clip mounting for counters 48 x 24 mm [1.89 x 0.94"]	cut-out: for cut-out 45 x 45 mm [1.77 x 1.77"] to cut-out 45 x 22.2 mm [1.77 x 0.94"]	suitable for: Codix 13x, 14x, 52x, 53x, W 15.5, W 16.5, W 17.5, H 37, H 37.5	black	T008883	Frequency displays Tachometers
					Position displays Multifunction devices
Adapter front bezel, 55 x 55 mm [2.16 x 2.16"] with clip mounting for counters 48 x 48 mm [1.89 x 1.89"]	cut-out: for cut-out 50 x 50 mm [1.97 x 1.97"] or \varnothing 50.5 mm [1.99"] to cut-out 45 x 45 mm [1.77 x 1.77"]	suitable for: H 57, HC 77, HW 66, HW 66 M	grey black	T008170 T008171	Energy meters Process devices
					Energy meters Process devices
Adapter front bezel, 55 x 55 mm [2.16 x 2.16"] with clip mounting for counters 48 x 48 mm [1.89 x 1.89"]	cut-out: for cut-out 50 x 50 mm [1.97 x 1.97"] to cut-out 45 x 45 mm [1.77 x 1.77"]	suitable for: 901, Codix 907 / 908, Codix 923 / 924, H 57, HC 77, HW 66, HW 66 M	black	T008853	Temperature devices
					Temperature devices Strain-gauge controllers

Accessories

Adapter front bezel		Details		Order no.	Product overview
Dimensions / Details	Dimensions in mm [inch]				Basics
Adapter front bezel, 60 x 75 mm [2.36 x 1.97"] with screw mounting for counters 48 x 48 mm	<i>cut-out:</i> for cut-out 50 x 50 mm [1.97 x 1.97"] to cut-out 45 x 45 mm [1.77 x 1.77"]	<i>suitable for:</i> 901, Codix 907 / 908, Codix 923 / 924, H 57, HC 77, HW 66, HW 66 M	black	T008860	Pulse counters
					Presets counters
Adapter front bezel, 72 x 72 mm [2.83 x 2.83"] with clip mounting for counters 48 x 48 mm (Mating clip must be ordered separately)	<i>cut-out:</i> for cut-out 68 x 68 mm [2.68 x 2.68"] to cut-out 45 x 45 mm [1.77 x 1.77"]	<i>suitable for:</i> 901, Codix 907 / 908, Codix 923 / 924, H 57, HC 77, HW 66, HW 66 M	grey black mating clip	T008176 T008177 T009420	Hour meters Timers
					Frequency displays Tachometers
Adapter front bezel, ø 72 mm [2.83"] with clip mounting for counters 48 x 48 mm	<i>cut-out:</i> for cut-out ø 60 mm [2.36"] to cut-out 45 x 45 mm [1.77 x 1.77"]	<i>suitable for:</i> 901, Codix 907 / 908, Codix 923 / 924, H 57, HC 77, HW 66, HW 66 M	black	N510226	Position displays
					Multifunction devices

Product overview
Basics

Pulse counters

Presets counters

Hour meters
Timers

Frequency displays
Tachometers

Position displays

Multifunction devices





Energy meters

Process devices

Temperature devices

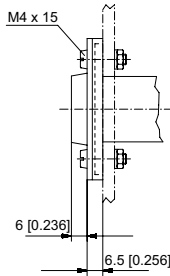
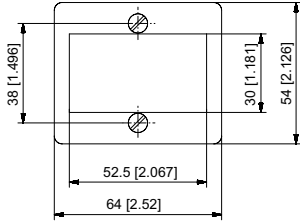
Strain-gauge controllers

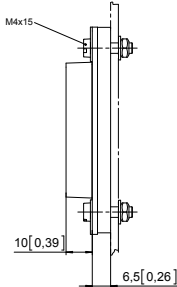
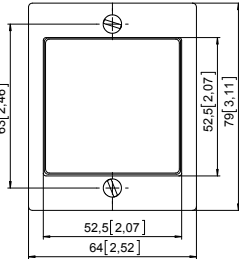
Accessories
Index

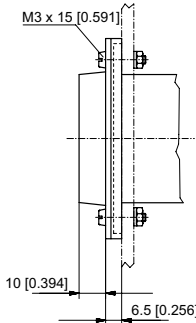
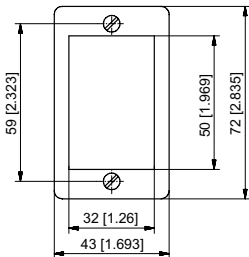
Sealing cover		Details		Order no.	Product overview Basics
Dimensions / Details	Dimensions in mm [inch]				
<p>Sealing cover type K1</p> <p>(screw mounting) for electromechanical counters and via adapter front bezel N003001 for counters 48 x 24 mm [1.89 x 0.94"]</p> 	<p><i>description:</i></p> <ul style="list-style-type: none"> - for front bezel 60 x 50 mm [2.36 x 1.97"] - flexible sealing cover made of soft PVC, with varnished steel metal frame and fixing screws - IP65 protection to DIN 40050 when installed  	<p><i>suitable for:</i></p> <p>B 1x.3x, HB 2x.3x via adapter front bezel: Codix 13x, 14x, 52x, 53x, W 15.5, W 16.5, W 17.5, H 37, H 37.5</p> <p>transparent / grey transparent / black</p>	<p>G008300</p> <p>G008301</p>	<p>Pulse counters</p> <p>Preset counters</p> <p>Hour meters Timers</p>	
<p>Sealing cover type K2</p> <p>(screw mounting) for electromechanical counters and via adapter front bezel T008860 for counters 48 x 48 mm [1.89 x 1.89"]</p> 	<p><i>description:</i></p> <ul style="list-style-type: none"> - for front bezel 75 x 60 mm [2.95x 2.36"] - flexible sealing cover made of soft PVC, with varnished steel metal frame and fixing screws - IP65 protection to DIN 40050 when installed  	<p><i>suitable for:</i></p> <p>BVa 15.3x, HVa 15.3x, MVa 16.3x via adapter front bezel: 901, Codix 907 / 908, Codix 923 / 924</p> <p>transparent / grey transparent / black</p>	<p>G008302</p> <p>G008303</p>	<p>Frequency displays Tachometers</p> <p>Position displays</p> <p>Multifunction devices</p> <p>Energy meters</p>	
<p>Sealing cover type KV3</p> <p>(screw mounting) for electromechanical counters</p> 	<p><i>description:</i></p> <ul style="list-style-type: none"> - for front bezel 39 x 68 mm [1.54 x 2.68"] - flexible sealing cover made of soft PVC, with varnished steel metal frame and fixing screws - IP65 protection to DIN 40050 when installed  	<p><i>suitable for:</i></p> <p>MVs 13.1x</p> <p>transparent / grey transparent / black</p>	<p>G008310</p> <p>G008311</p>	<p>Process devices</p> <p>Temperature devices</p> <p>Strain-gauge controllers</p>	

Product overview Basics

Pulse counters

Preset counters

Hour meters
Timers

Frequency displays
Tachometers

Position displays

Multifunction devices

Energy meters



Process devices

Temperature devices

Strain-gauge controllers

Accessories Index

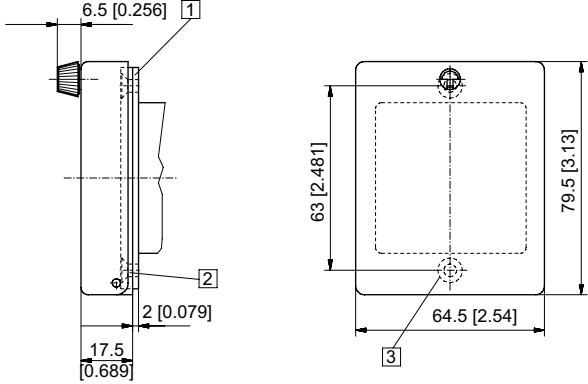
Transparent cover

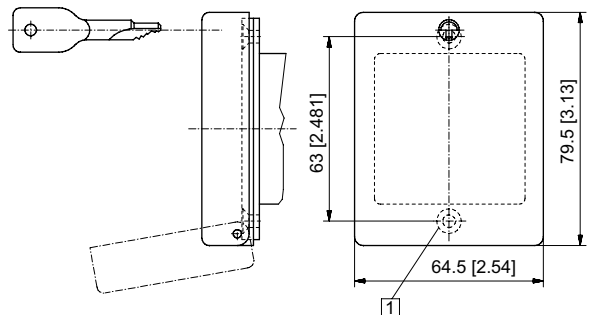
Dimensions / Details	Dimensions in mm [inch]	Order no.
<p>Transparent cover type 2 Dv (mounted on bezel) lockable, IP65 for counter with cut-out 45 x 45 mm [1.77 x 1.77"] and front bezel 48 x 48 mm [1.89 x 1.89"]</p>  <p> 1 Gasket 2 Front bezel 3 Countersinking Bf4, DIN 74 </p>	<p><i>description:</i></p> <ul style="list-style-type: none"> - for cut-out 50 x 50 mm [1.97 x 1.97"] - screw mounting - IP65 protection - with gaskets and screws <p><i>suitable for:</i></p> <p>901, Codix 907 / 908, Codix 923 / 924, H 57, HC 77, HW 66, HW 66 M</p> <p>transparent / black</p> 	<p>G008143</p>
<p>Transparent cover type 2 Dvs (mounted on bezel) key lockable, IP65 for counter with cut-out 45 x 45 mm [1.77 x 1.77"] and front bezel 48 x 48 mm [1.89 x 1.89"]</p>  <p>1 Countersinking Bf4, DIN 74</p>	<p><i>description:</i></p> <ul style="list-style-type: none"> - for cut-out 50 x 50 mm [1.97 x 1.97"] - screw mounting - IP65 protection - with gaskets and screws <p><i>suitable for:</i></p> <p>901, Codix 907 / 908, Codix 923 / 924, H 57, HC 77, HW 66, HW 66 M</p> <p>transparent / black</p> 	<p>G008153</p>

- Product overview Basics
- Pulse counters
- Preset counters
- Hour meters Timers
- Frequency displays Tachometers
- Position displays
- Multifunction devices
- Energy meters
- Process devices
- Temperature devices
- Strain-gauge controllers
- Accessories Index

Accessories

Transparent cover

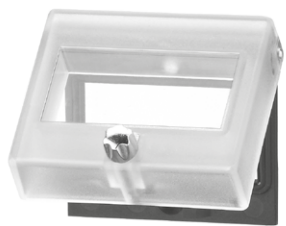
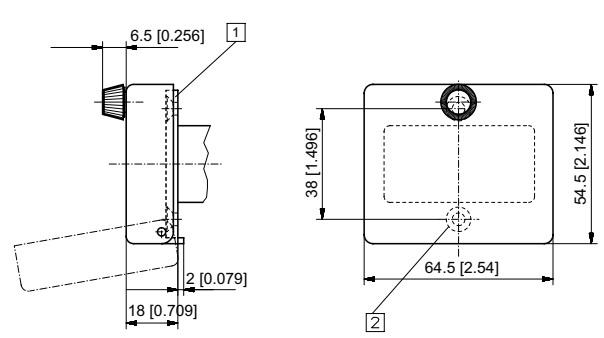
Dimensions / Details	Dimensions in mm [inch]	Order no.	Product overview Basics
<p>Transparent cover type 1 Dv (mounted on bezel) lockable, IP65 for counters with cut-out 50 x 25 mm [1.97 x 0.98"] or 45 x 22.2 mm [1.77 x 0.94"]</p>	<p><i>description:</i></p> <ul style="list-style-type: none"> - for cut-out 54 x 29 mm [2.13 x 1.14"] - screw mounting on front bezel F1B or adapter front bezel N003001 - IP65 protection with front bezel <p><i>suitable for:</i></p> <p>B 1x.3x, HB 2x.3x</p> <p>transparent / black</p> <p>with front bezel F1B: B 1x.0x, HB 2x.0x</p> <p>via adapter front bezel N003001: Codix 13x, 14x, 52x, 53x, W 15.5, W 16.5, W 17.5, H 37, H 37.5</p>	<p>N003002</p>	Pulse counters
 <p>1 Front bezel 2 Countersinking Bf4, DIN 74</p>		Preset counters	Hour meters Timers
			Frequency displays Tachometers
			Position displays
			Multifunction devices
			Energy meters
			Process devices
			Temperature devices
			Strain-gauge controllers
			Accessories Index

Front bezel

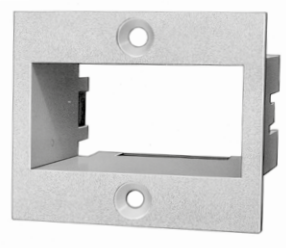
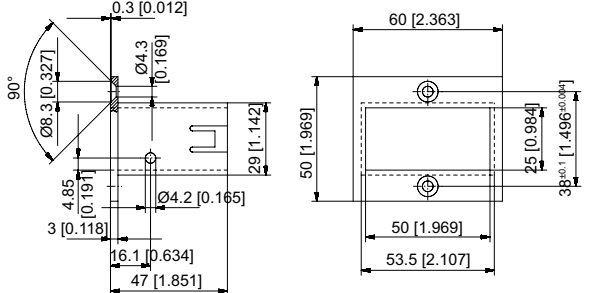
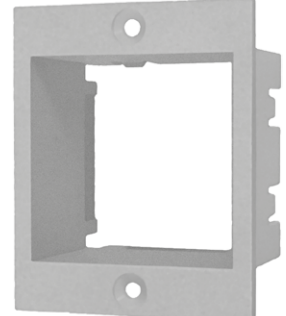
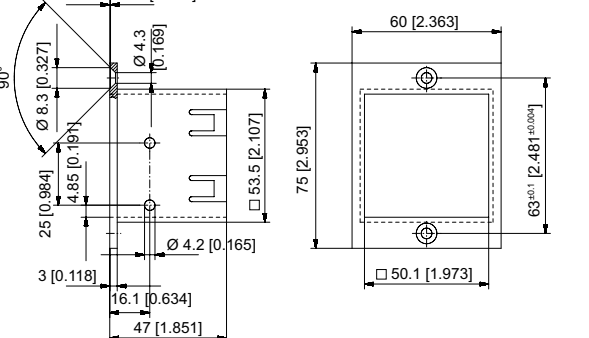
Dimensions / Details	Dimensions in mm [inch]	Order no.
<p>Front bezel type F1B</p> <p>for plug-in counters B 1x.0x and HB 2x.0x in socket box type 945.2</p> 	<p><i>description:</i></p> <ul style="list-style-type: none"> - for cut-out 54 x 29 mm [2.13 x 1.14"] - screw mounting <p><i>suitable for:</i></p> <p>B 1x.0x, HB 2x.0x</p> <p>beige black</p> 	<p>G007501 G007502</p>
<p>Front bezel type F2B</p> <p>for plug-in counters BVa 15.0x in socket box type 946.1 or 2 x B- or HB counters in socket box type 945.2</p> 	<p><i>description:</i></p> <ul style="list-style-type: none"> - for cut-out 54 x 54 mm [2.13 x 2.13"] - screw mounting <p><i>suitable for:</i></p> <p>BVa 15.0x</p> <p>beige black</p> 	<p>G007503 G007504</p>

- Product overview Basics
- Pulse counters
- Preset counters
- Hour meters Timers
- Frequency displays Tachometers
- Position displays
- Multifunction devices
- Energy meters
- Process devices
- Temperature devices
- Strain-gauge controllers
- Accessories Index

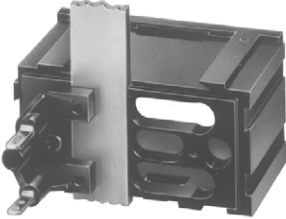
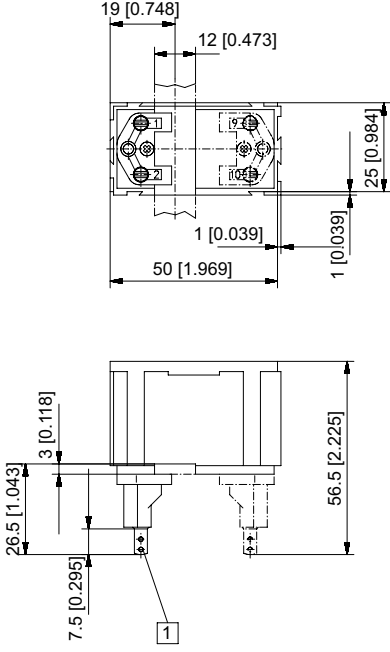
Socket box		Details			Order no.	Product overview Basics
Dimensions / Details	Dimensions in mm [inch]					
Socket box type 945.2 	<i>description:</i> for plug-in connection in front bezel F1B	<i>suitable for:</i> B 1x.0x, HB 2x.0x	black	G008434	Pulse counters Preset counters Hour meters Timers Frequency displays Tachometers Position displays	Multifunction devices Energy meters Process devices Temperature devices Strain-gauge controllers
						
	1 Flat pin 0.8 x 2.8 [0.032 x 0.11"] silver-plated					



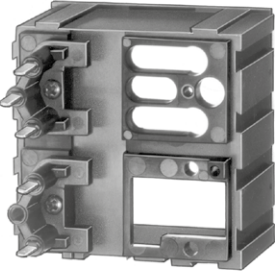
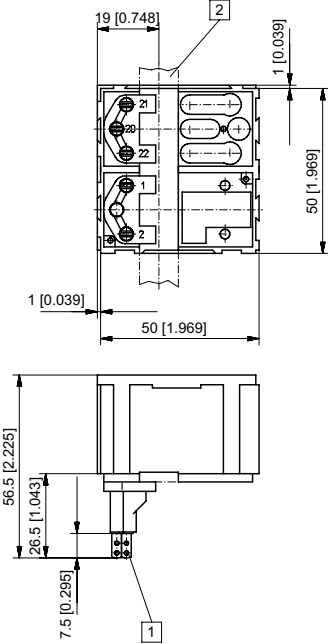

Accessories

Socket box Details

Dimensions / Details	Dimensions in mm [inch]			Order no.
Socket box type 926.1 	<i>description:</i> for plug-in connection	<i>suitable for:</i> MVs 16	transparent	G008433
Socket box type 946.1 	<i>description:</i> for plug-in connection in front bezel F2B	<i>suitable for:</i> BVa 15, HVa 15	transparent	G008439
1 Flat pin 0.8 x 2.8 [0.032 x 0.11"] silver-plated 2 Fixing strip 3 x 12 mm [0.12 x 0.47"]				

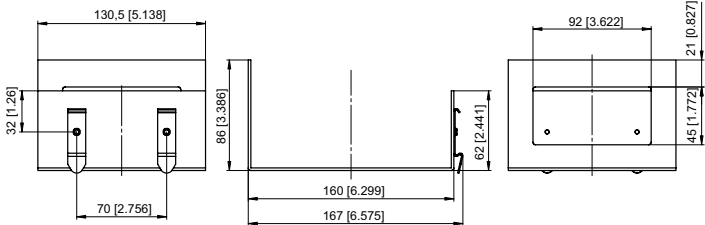
- Product overview Basics
- Pulse counters
- Preset counters
- Hour meters Timers
- Frequency displays Tachometers
- Position displays
- Multifunction devices
- Energy meters
- Process devices
- Temperature devices
- Strain-gauge controllers
- Accessories Index

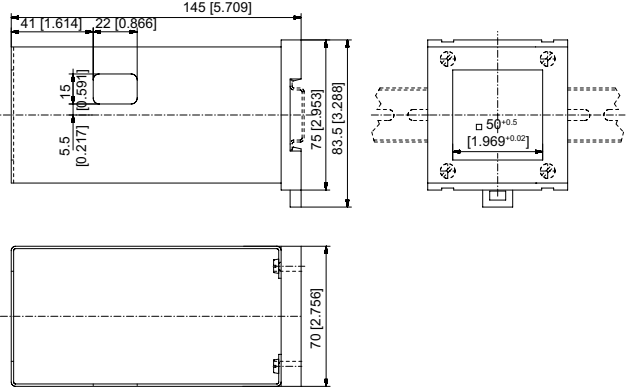
Accessories

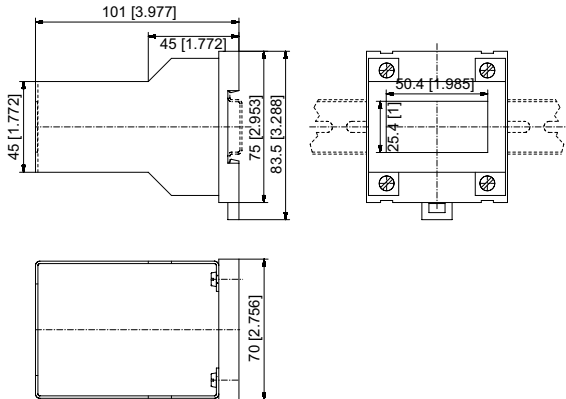
Mounting frame		Details		Order no.	Product overview
Dimensions / Details		Dimensions in mm [inch]			Basics
<p>Mounting frame with cut-out 92 x 45 mm [3.62 x 1.77"]</p> <p>for counters 96 x 48 mm [3.78 x 1.89"]</p> 	<p><i>description:</i></p> <p>for snap-on mounting on 35 mm [1.38"] top-hat DIN rail</p>	<p><i>suitable for:</i></p> <p>Codix 54x, 55x, 56x, 57x</p> <p>grey</p>		G300005	Pulse counters
					Preset counters
<p>Mounting frame with cut-out 50 x 50 mm [1.97 x 1.97"]</p> <p>for counters 53 x 53 mm [2.09 x 2.09"] and 55 x 55 mm [2.16 x 2.16"] (cut-ou 45 x 45 mm [1.77 x 1.77"] via supplied adapter for counter 48 x 48 mm [1.89 x 1.89"])</p> 	<p><i>description:</i></p> <p>for snap-on mounting on 35 mm [1.38"] top-hat DIN rail</p>	<p><i>suitable for:</i></p> <p>BVa 15.21, HVa 15.21, MVs 16.2x chromated</p> <p>via supplied adapter for: 901, Codix 907 / 908, Codix 923 / 924, H 57, HC 77, HW 66, HW 66 M,</p>		G300003	Hour meters Timers
					Frequency displays Tachometers
					Position displays
					Multifunction devices
<p>Mounting frame with cut-out 50 x 25 mm [1.97 x 0.98"]</p> <p>for counters 53 x 28 mm (cut-out 45 x 22.2 mm [1.77 x 0.94"] via separate adapter T008180 or T008165 for counter 48 x 24 mm [1.89 x 0.94"])</p> 	<p><i>description:</i></p> <p>for snap-on mounting on 35 mm [1.38"] top-hat DIN rail</p>	<p><i>suitable for:</i></p> <p>B 1x.2x, HB 2x.2x., H 37.2 chromated</p> <p>via supplied adapter T008180 for: Codix 13x, 14x, 52x, 53x, W 15.5, W 16.5, W 17.5, H 37.5</p> <p>via adapter T008165: H 37</p>		G300004	Energy meters
					Process devices
					Temperature devices
					Strain-gauge controllers

DIN rail mount Details

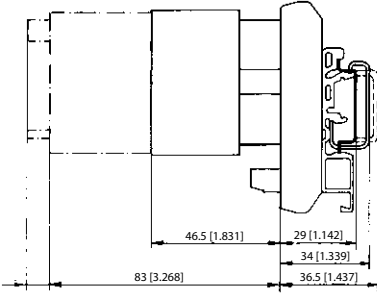
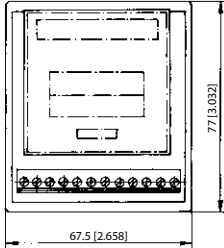
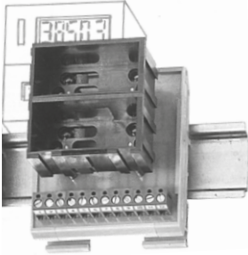
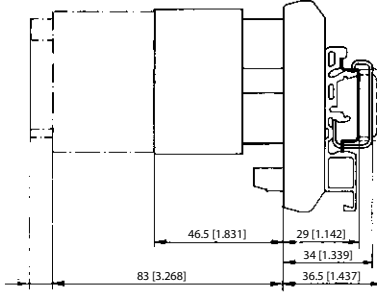
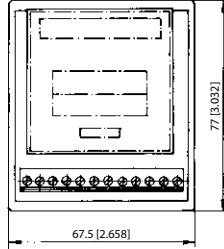
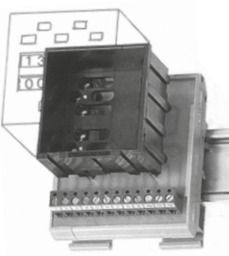
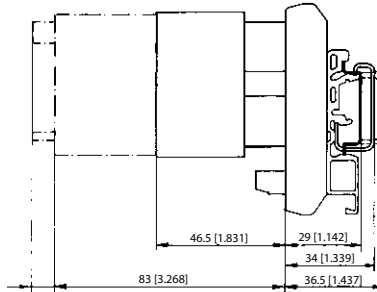
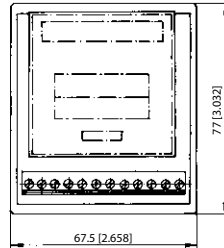
Dimensions / Details	Dimensions in mm [inch]		Order no.
<p>DIN rail mount SR 1 for B and HB counters</p> 	<p><i>description:</i> for snap-on mounting on 35 mm [1.38"] top-hat DIN rail</p>	<p><i>suitable for:</i> B and HB counters</p>  	G300000
<p>DIN rail mount SR 2 for 2 x B and HB counters</p> 	<p><i>description:</i> for snap-on mounting on 35 mm [1.38"] top-hat DIN rail</p>	<p><i>suitable for:</i> B and HB counters</p>  	G300001
<p>DIN rail mount SR 3 for BVa and HVa counters</p> 	<p><i>description:</i> for snap-on mounting on 35 mm [1.38"] top-hat DIN rail</p>	<p><i>suitable for:</i> BVa and HVa counters</p>  	G300002

Product overview
Basics

Pulse counters

Preset counters

Hour meters
Timers

Frequency displays
Tachometers

Position displays

Multifunction
devices

Energy meters

Process devices

Temperature
devices



Strain-gauge
controllers

Accessories
Index

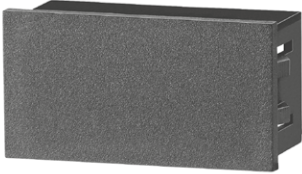
Accessories

Enclosure blind		Details			Order no.	Product overview Basics
Dimensions / Details	Dimensions in mm [inch]					
Enclosure blind, 48 x 24 mm [1.89 x 0.94"] for counters 48 x 24 mm [1.89 x 0.94"] and 53 x 28 mm [2.09 x 1.10"] (via adapter front bezel T008180 or T008181; included in delivery)	<i>description:</i> for cut-out 45 x 22.2 mm [1.77 x 0.94"] and cut-out 50 x 25 mm [1.97 x 0.98"]	<i>suitable for:</i> Codix 13x, 14x, 52x, 53x, W 15.5, W 16.5, W 17.5, H 37, H 37.5	anthracite	G003836	Pulse counters	
					Presets counters	
Enclosure blind, 53 x 28 mm [2.09 x 1.10"] for counters 53 x 28 mm [2.09 x 1.10"]	<i>description:</i> for cut-out 50 x 25 mm [1.97 x 0.98"]	<i>suitable for:</i> B and HB counters	black	T005753	Hour meters Timers	
					Frequency displays Tachometers	
					Position displays	
					Multifunction devices	
					Energy meters	
					Process devices	
					Temperature devices	
					Strain-gauge controllers	

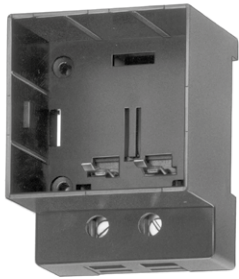
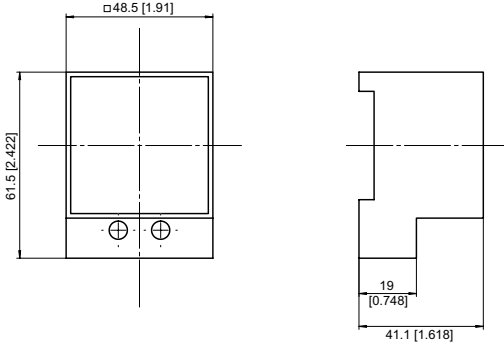
Other accessories Details

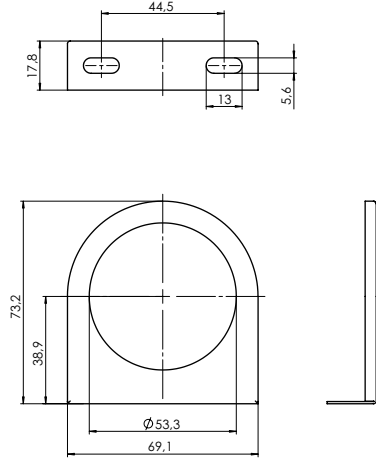
Dimensions / Details	Dimensions in mm [inch]			Order no.
Terminal cover type Typ KA 37 for counter H 37 	<i>description:</i> 2-pcs. per counter required	<i>suitable for:</i> H 37	transparent	T051687
Base mount socket for H 57 / AH 57 counters 	<i>description:</i> for DIN rail mount	<i>suitable for:</i> H 57	black	G008040
				
Mounting support for HR 76.2, HR 47 	<i>description:</i> for mounting the counter onto a flat plate	<i>suitable for:</i> HR 76.2, HR 47	black	N510199
				

 Product overview
Basics

Pulse counters

Preset counters

 Hour meters
Timers

 Frequency displays
Tachometers

Position displays

 Multifunction
devices

Energy meters

Process devices

 Temperature
devices

 Strain-gauge
controllers

 Accessories
Index

Accessories

Other accessories		Details		
Dimensions / Details	Dimensions in mm [inch]			Order no.
Adapter and anti-vibration set for HR 47 	<i>description:</i> Adapter and anti-vibration set for panel cut-out \varnothing 71 mm [2.80"], outer diameter \varnothing 80 mm [3.15"] <i>Delivery specification:</i> 1 x rubber adapter 2 x cover mask 1 x spacer ring 1 x clamping bracket, shortened	<i>suitable for:</i> HR 47	black	255319

- Product overview Basics
- Pulse counters
- Preset counters
- Hour meters Timers
- Frequency displays Tachometers
- Position displays
- Multifunction devices
- Energy meters
- Process devices
- Temperature devices
- Strain-gauge controllers
- Accessories Index

Mounting examples for optional accessories

For counters 48 x 24 mm [1.89 x 0.94"]

Codix 13X / Codix 14X / Codix 52X / Codix 53X / W15.51 / W16.50 / W17.50 / H37 / H37.5

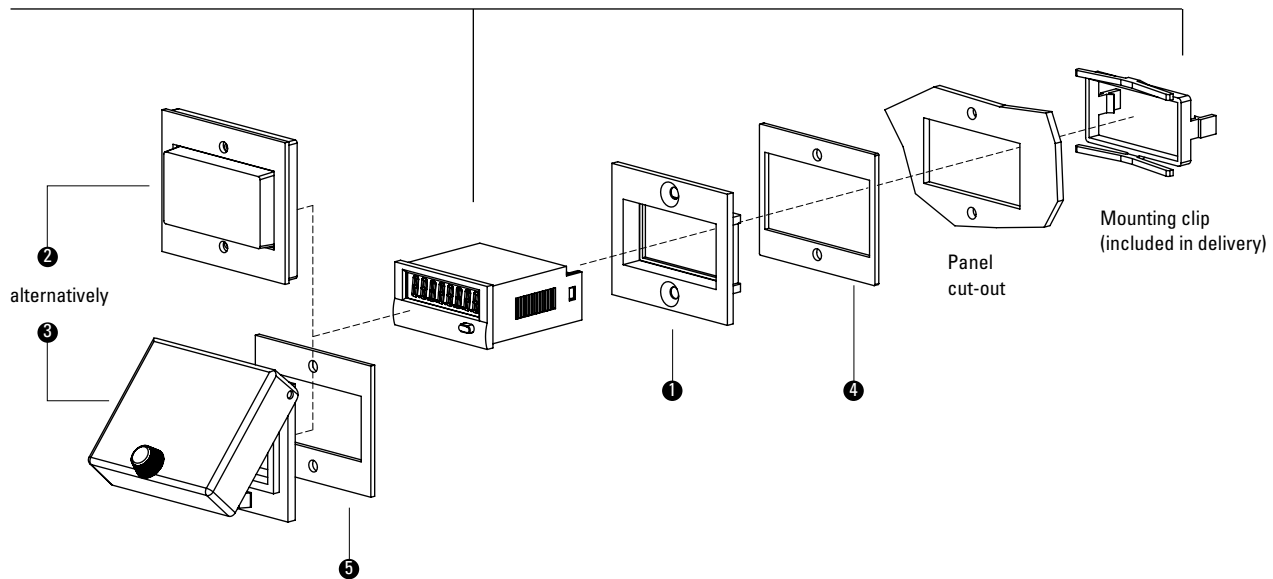

		Type / size	Description		Order no.	Details see page	④ suitable ⑤ gasket
① Adapter front bezel		53 x 28 mm [2.09 x 1.10"]	for cut-out 50 x 25 mm [1.97 x 0.98"] to cut-out 45 x 22.2 mm [1.77 x 0.94"]	grey black anthracite	T008164 T008165 T008180	312	N511015
		56 x 40 mm [2.20 x 1.57"]	for cut-out 50 x 25 mm [1.97 x 0.98"] to cut-out 45 x 22.2 mm [1.77 x 0.94"]	black anthracite	T008161 T008181	312	N511045
		72 x 36 mm [2.83 x 1.42"]	for cut-out 68 x 33 mm [2.68 x 1.30"] to cut-out 45 x 22.2 mm [1.77 x 0.94"]	black and silver anodised as set	162704 Set	312	–
	①	60 x 50 mm [2.36 x 1.97"]	for cut-out 54 x 29 mm [2.13 x 1.14"] to cut-out 45 x 22.2 mm [1.77 x 0.94"]	black	N003001	313	④ N511005
		48 x 48 mm [1.89 x 1.89"]	for cut-out 45 x 45 mm [1.77 x 1.77"] to cut-out 45 x 22.2 mm [1.77 x 0.94"]	black	T008883	313	–
② Sealing cover IP65		K1	only in conjunction with adapter front bezel 60 x 50 mm N003001	transparent / grey transparent / black	G008300 G008301	315	–
③ Transparent cover IP65		1 Dv (mounted on bezel)	cover lockable,, for cut-out 54 x 29 mm, only in conjunction with adapter front bezel 60 x 50 mm N003001	transparent / black	N003002	317	⑤ N511019
Mounting frame	via adapter T008180				G300004	321	
Enclosure blind					G003836	323	

Product overview
Basics

Pulse counters

Preset counters

Hour meters
Timers

Frequency displays
Tachometers

Position displays

Multifunction
devices

Energy meters

Process devices

Temperature
devices

Strain-gauge
controllers

Accessories
Index

Accessories

Mounting examples for optional accessories For counters 48 x 48 mm [1.89 x 1.89"]

Codix 901 / Codix 907 / Codix 908 / Codix 923 / Codix 924 / H 57 / HC 77 / HW 66

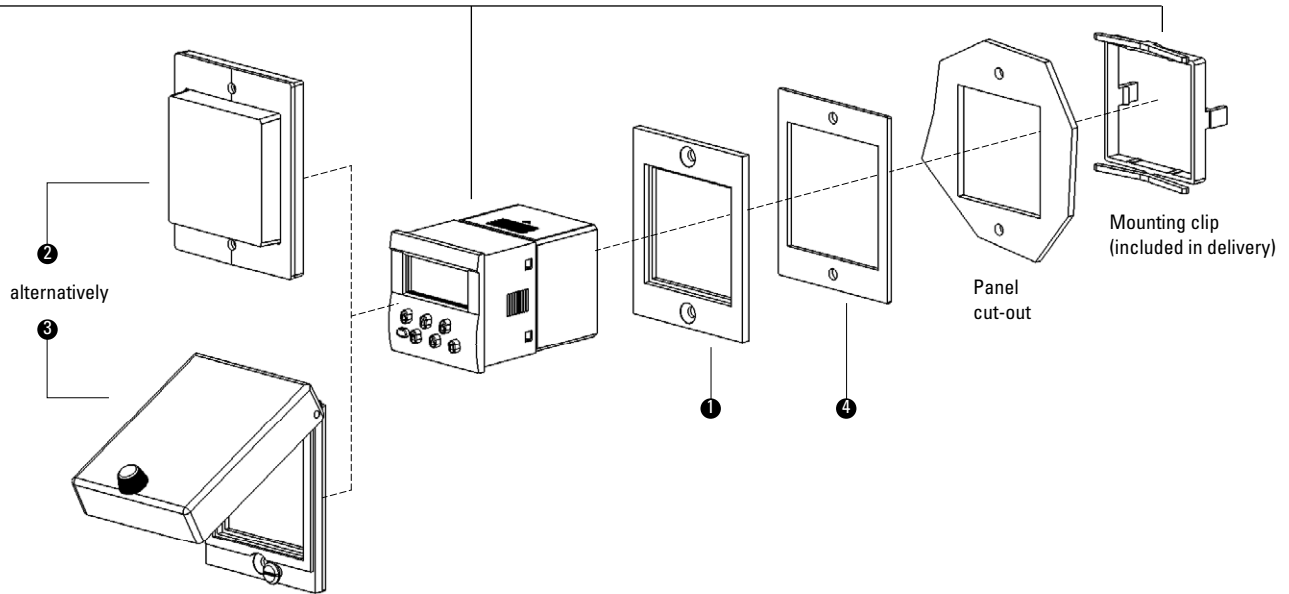

		Type / size	Description		Order no.	Details see page	④ suitable gasket
① Adapter front bezel		55 x 55 mm	for cut-out 50 x 50 mm [1.97 x 1.97"] 0r ø 50.5 mm to cut-out 45 x 45 mm [1.77 x 1.77"]	grey black	T008170 T008171	313	N511017
		55 x 55 mm	for cut-out 50 x 50 mm [1.97 x 1.97"] to cut-out 45 x 45 mm [1.77 x 1.77"]	black	T008853	313	N511004
	①	60 x 75 mm	for cut-out 50 x 50 mm [1.97 x 1.97"] to cut-out 45 x 45 mm [1.77 x 1.77"]	black	T008860	314	④ N511020
		72 x 72 mm	for cut-out 68 x 68 mm to cut-out 45 x 45 mm [1.77 x 1.77"]	grey black mating clip	T008176 T008177 T009420	314	N511016
		ø 72 mm	for cut-out ø 60 mm to cut-out 45 x 45 mm [1.77 x 1.77"]	black	N510226	314	–
② Sealing cover IP65		K2	only in conjunction with adapter front bezel 60 x 75 mm T008860	transparent / grey	G008302	315	–
				transparent / black	G008303		
③ Transparent cover IP65 with gasket		2 Dv (mounted on bezel)	cover lockable, for cut-out 50 x 50 mm, only in conjunction with adapter front bezel 60 x 75 mm T008860	transparent / black	G008143	316	–
		2 Dvs (mounted on bezel)	cover key lockable, for cut-out 50 x 50 mm, only in conjunction with adapter front bezel 60 x 75 mm T008860	transparent / black	G008153	316	–
Mounting frame					G300003	321	

Product overview
Basics
Pulse counters
Preset counters
Hour meters
Timers
Frequency displays
Tachometers
Position displays
Multifunction devices
Energy meters
Process devices
Temperature devices
Strain-gauge controllers
Accessories
Index

Mounting examples for optional accessories

For counters 50 x 25 mm [1.97 x 0.98"]

B16.01 / B18.00 / HB26.01.3 / HB27.00.3

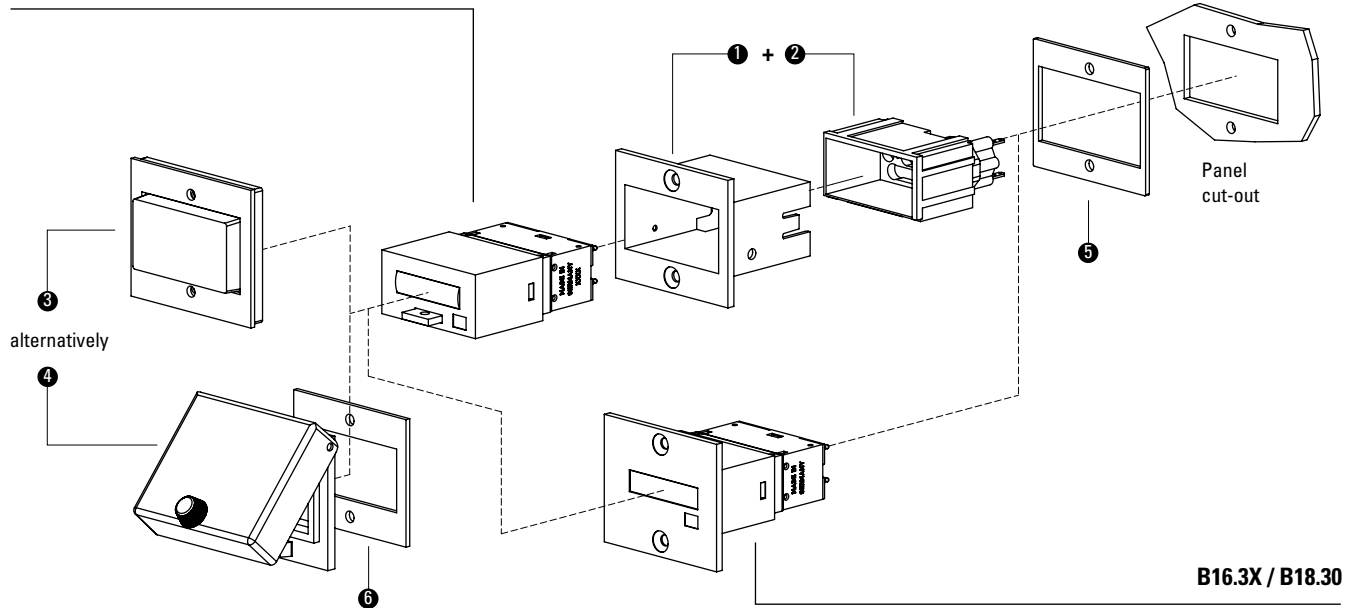

		Type / size	Description		Order no.	Details see page	5 suitable 6 gasket
1 Front bezel		F1B	for cut-out 54 x 29 mm (only in conjunction with socket box G008434)	beige black	G007501 G007502	318	5 N511005
2 Socket box		945.2	for plug-in connection in front bezel F1B	black	G008434	319	—
3 Sealing cover IP65		K1	only in conjunction with front bezel F1B	transparent / grey transparent / black	G008300 G008301	315	—
4 Transparent cover IP65		1 Dv (mounted on bezel)	cover lockable, for cut-out 54 x 29 mm, only in conjunction with front bezel F1B	transparent / black	N003002	317	6 N511019
DIN rail mount					G300000	322	

Product overview
Basics

Pulse counters

Preset counters

Hour meters
Timers

Frequency displays
Tachometers

Position displays

Multifunction
devices

Energy meters

Process devices

Temperature
devices

Strain-gauge
controllers

Accessories
Index

Accessories

Mounting examples for optional accessories For 2 counters 50 x 25 mm [1.97 x 0.98"]

B16.01 / B18.00 / HB26.01.3 / HB27.00.3 (any combination of 2 counters)

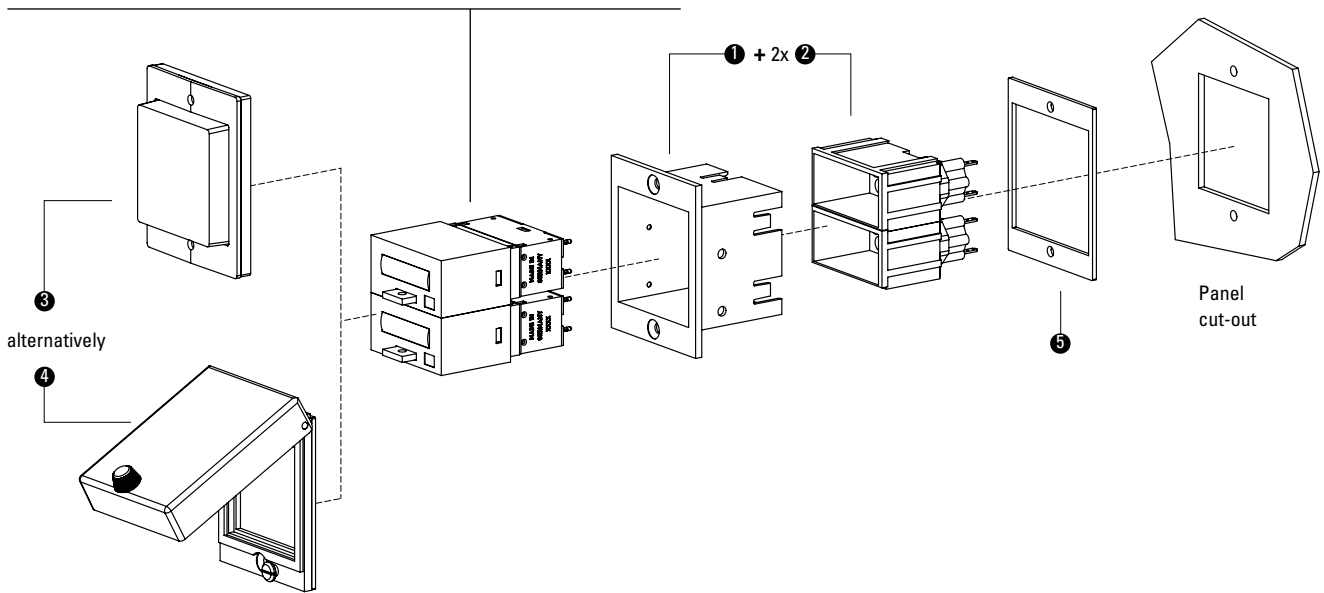

		Type / size	Description		Order no.	Details see page	5 suitable gasket
1 Front bezel		F2B	for cut-out 54 x 54 mm (only in conjunction with 2 socket boxes G008434)	beige black	G007503 G007504	318	5 N511003
2 Socket box (2x)		945.2	for plug-in connection in front bezel F2B	black	G008434	319	–
3 Sealing cover IP65		K2	only in conjunction with front bezel F2B	transparent / grey transparent / black	G008302 G008303	315	–
4 Transparent cover IP65 with gasket		2 Dv (mounted on bezel)	cover lockable, for cut-out 50 x 50 mm, only in conjunction with front bezel F2B	transparent / black	G008143	316	–
		2 Dvs (mounted on bezel)	cover key lockable, for cut-out 50 x 50 mm, only in conjunction with front bezel F2B	transparent / black	G008153	316	–
DIN rail mount					G300001	322	

Product overview
Basics

Pulse counters

Preset counters

Hour meters
Timers

Frequency displays
Tachometers

Position displays

Multifunction
devices

Energy meters

Process devices

Temperature
devices

Strain-gauge
controllers

Accessories
Index

Mounting examples for optional accessories

For counters 50 x 50 mm [1.97 x 1.97"]

BVa 15.01

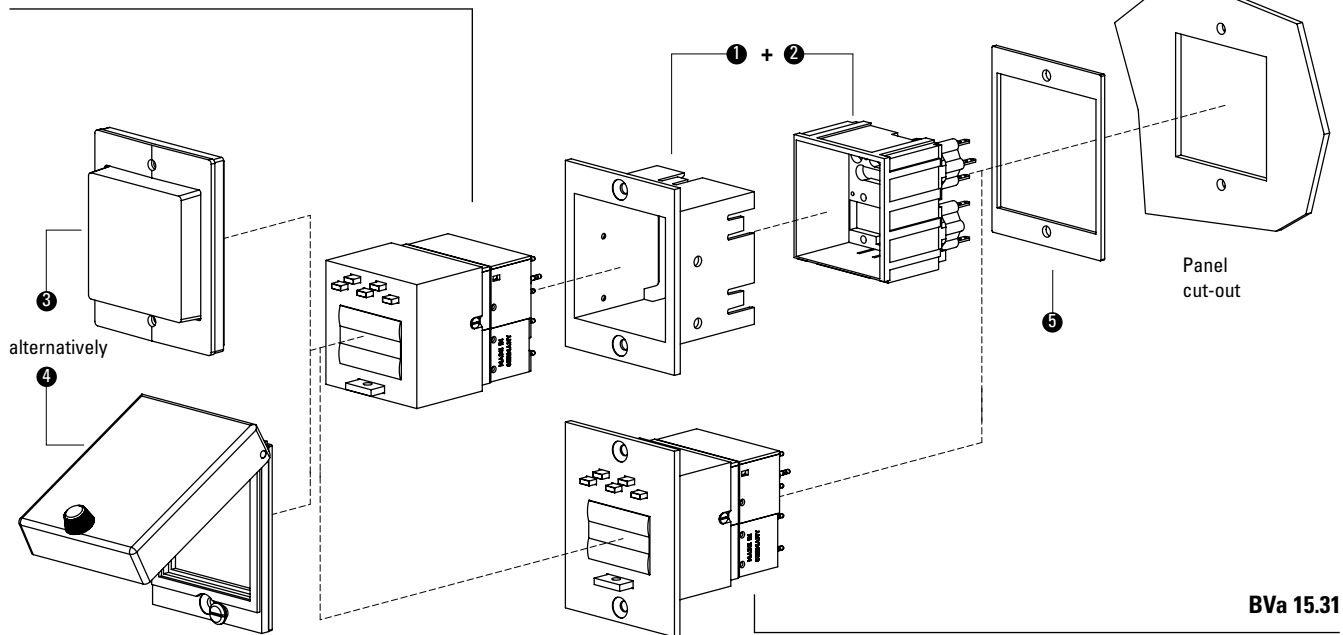

		Type / size	Description		Order no.	Details see page	5 suitable gasket
1 Front bezel		F2B	for cut-out 54 x 49 mm (only in conjunction with 2 socket boxes G008434)	beige black	G007503 G007504	318	5 N511003
2 Socket box		946.1	for plug-in connection in front bezel F2B	black	G008439	320	—
3 Sealing cover IP65		K2	only in conjunction with front bezel F2B	transparent / grey transparent / black	G008302 G008303	315	—
4 Transparent cover IP65 with gasket		2 Dv (mounted on bezel)	cover lockable, for cut-out 50 x 50 mm, only in conjunction with front bezel F2B	transparent / black	G008143	316	—
		2 Dvs (mounted on bezel)	cover key lockable for cut-out 50 x 50 mm, only in conjunction with front bezel F2B	transparent / black	G008153	316	—
DIN rail mount					G300002	322	

Product overview
Basics

Pulse counters

Preset counters

Hour meters
Timers

Frequency displays
Tachometers

Position displays

Multifunction
devices

Energy meters

Process devices

Temperature
devices

Strain-gauge
controllers

Accessories
Index

Accessories

Gaskets		Overview				
Gasket, outer diameter	for cut-out	thickness	suitable for		Order no.	
60 x 75 mm [2.36 x 2.95"]	54.4 x 54.4 mm [2.14 x 2.14"]	2,0 mm [0.079"]	F2B (G007503, G007504) + BVa 15.0x, MVs 16, T008860	black	N511003	Product overview Basics
58 x 58 mm [2.28 x 2.28"]	50.2 x 50.2 mm [1.98 x 1.98"]	1,5 mm [0.059"]	BVa 15.2x, HVa 15.2x, MVs 16.2x, T008853	black	N511004	Pulse counters
60 x 50 mm [2.36 x 1.97"]	54.4 x 29.4 mm [2.14 x 1.16"]	2,0 mm [0.079"]	F1B (G007501, G007502) + B 1x.0x, HB 2x.0x, N003001	black	N511005	
58 x 33 mm [2.28 x 1.30"]	50.2 x 25.2 mm [1.98 x 0.99"]	2,0 mm [0.079"]	B 1x.2x, HB 2x.2x	black	N511006	Preset counters
39 x 40 mm [1.54 x 1.57"]	33.3 x 22 mm [1.31 x 0.87"]	1,5 mm [0.059"]	Mk 14.11, PMk 14.11, Hk 17.151	black	N511011	
53 x 28 mm [2.09 x 1.10"]	50 x 25 mm [1.97 x 0.98"]	1,0 mm [0.039"]	B 1x.2x, HB 2x.2x, H 37.2, H 37.4, T008164, T008165, T008180	black	N511015	Hour meters Timers
72 x 72 mm [2.83 x 2.83"]	ø 50.5 mm and 45 x 45 mm	2,0 mm [0.079"]	H 57.72, HC 77.72, T008176, T008177	black	N511016	
55 x 55 mm [2.16 x 2.16"]	ø 50.5 mm and 45 x 45 mm	2,0 mm [0.079"]	H 57.55, HC 77.55, T008171, T008170	black	N511017	Frequency displays Tachometers
48 x 48 mm [1.89 x 1.89"]	ø 50 mm and 45 x 45 mm	1,5 mm [0.059"]	H 57, HC 77, HW 66	black	N511018	
60 x 50 mm [2.36 x 1.97"]	50 x 25 mm [1.97 x 0.98"]	2,0 mm [0.079"]	B 1x.3x, HB 2x.3x	black	N511019	Position displays
60 x 75 mm [2.36 x 2.95"]	50 x 50 mm [1.97 x 1.97"]	2,0 mm [0.079"]	BVa 15.3x, HVa 15.3x, MVs 16.3x, T008860	black	N511020	
48 x 48 mm [1.89 x 1.89"]	45 x 45 mm [1.77 x 1.77"]	0,5 mm [0.02"]	901, Codix 907 / 908, Codix 923 / 924, H 57, HC 77, HW 66	black	N511028	Multifunction devices
48 x 24 mm [1.89 x 0.94"]	45 x 22 mm [1.77 x 0.87"]	0,5 mm [0.02"]	Codix 13x, Codix 14x, Codix 52x, Codix 53x, W 15.5, W 16.5, W 17.5, H 37, H 37.5	black	N511029	
96 x 49 mm [3.78 x 1.93"]	92 x 45 mm [3.62 x 1.77"]	1,5 mm [0.059"]	Codix 54x, Codix 55x	black	N511031	Energy meters
49 x 49 mm [1.93 x 1.93"]	45 x 45 mm [1.77 x 1.77"]	1,5 mm [0.059"]	901, Codix 907 / 908, Codix 923 / 924, H 57, HC 77, HW 66	black	N511033	
49 x 25 mm [1.93 x 0.98"]	45 x 22 mm [1.77 x 0.87"]	1,5 mm [0.059"]	Codix 13x, Codix 14x, Codix 52x, Codix 53x, W 15.5, W 16.5, W 17.5, H 37, H 37.5	black	N511034	Process devices
36 x 24 mm [1.42 x 0.94"]	33.3 x 22 mm [1.31 x 0.87"]	1,0 mm [0.039"]	HK 17.251 ... 56	black	N511040	
55 x 26 mm [2.17 x 1.02"]	33.3 x 22 mm [1.31 x 0.87"]	1,5 mm [0.059"]	HK 17.451	black	N511043	Temperature devices
56 x 40 mm [2.20 x 1.57"]	50 x 25 mm [1.97 x 0.98"]	1,5 mm [0.059"]	H37.1, B16.10, B16.11, B18.10, T008161, T008181	black	N511045	
32 x 15 mm [1.26 x 0.59"]	27 x 13 mm [1.06 x 0.51"]	0,5 mm [0.02"]	K07.20, HK07.20	black	N511058	Strain-gauge controllers
ø 71.1 mm [2.80"]	ø 50.8 mm [2"]	1,5 mm [0.059"]	HR 76.1	black	N511150	
96 x 48 mm [3.78 x 1.89"]	92 x 45 mm [3.62 x 1.77"]	1,5 mm [0.059"]	Codix 56x	black	N511181	Accessories Index
ø 58 mm [2.28"]	ø 50 mm [1.97"]	1,0 mm [0.039"]	HR 47	black	N511182	

List of order numbers

Order no.	Type / description	Page	Order no.	Type / description	Page
0.135.100.XXX	HR 76.1	198	1.660.950.XXX	K 67.95	85
0.135.200.XXX	HR 76.2	198	1.700.200.XXX	K 46.20	82
0.170.000.XXX	SH 17	194	1.700.800.XXX	K 46.80	82
1.100.200.XXX	K 04.20	88	1.700.950.XXX	K 46.95	82
1.100.401.XXX	K 04.40	88	1.710.200.XXX	K 47.20	82
1.110.200.XXX	K 05.20	88	1.710.800.XXX	K 47.80	82
1.120.200.XXX	K 06.20	88	1.710.900.XXX	K 47.90	82
1.120.800.XXX	K 06.80	88	1.710.910.XXX	K 47.91	82
1.130.000.XXX	AK 07.00	88	1.740.500.XXX.550	W 17.50	99
1.130.200.XXX	K 07.20	88	1.740.900.XXX	W 17.90	99
1.130.401.XXX	K 07.40	88	2.100.010.XXX	BVa 15.01	145
1.130.501.XXX	K 07.50	88	2.100.110.XXX	BVa 15.11	145
1.130.800.XXX	K 07.80	88	2.100.210.XXX	BVa 15.21	145
1.130.900.XXX	K 07.90	88	2.100.310.XXX	BVa 15.31	145
1.132.101.XXX	SK 07.1	94	2.300.110.XXX	MVs 13.11	150
1.150.210.XXX	W 15.21	96	2.300.130.XXX	MVs 13.13	150
1.150.510.XXX.550	W 15.51	96	2.300.210.XXX	MVs 13.21	150
1.160.200.XXX	W 16.20	99	2.300.230.XXX	MVs 13.23	150
1.160.601.XXX	W 16.60	99	2.310.110.XXX	MVs 13.11/2	150
1.180.110.XXX	Bk 14.11	102	2.310.130.XXX	MVs 13.13/2	150
1.180.210.XXX	Bk 14.21	102	2.310.210.XXX	MVs 13.21/2	150
1.230.012.XXX	B 16.01	104	2.310.230.XXX	MVs 13.23/2	150
1.230.100.XXX	B 16.10	104	2.320.230.XXX	MVs 16.23	154
1.230.110.XXX	B 16.11	104	255319	Adapter and anti-vibration set	325
1.230.200.XXX	B 16.20	104	3.060.200.383	HK 47.20	177
1.230.210.XXX	B 16.21	104	3.060.800.383	HK 47.80	177
1.230.300.XXX	B 16.30	104	3.100.000.383	AHK 07.00	179
1.230.310.XXX	B 16.31	104	3.100.200.383	HK 07.20	179
1.260.002.XXX	B 18.00	104	3.100.900.383	HK 07.90	179
1.260.100.XXX	B 18.10	104	3.100.920.383	HK 07.92	179
1.260.200.XXX	B 18.20	104	3.102.101.XXX	SHK 07.1	192
1.260.300.XXX	B 18.30	104	3.107.200.383	HK 07.20.35	179
1.310.110.XXX	Mk 14.11	110	3.130.051.XXX	HK 17.051.39	182
1.310.210.XXX	Mk 14.21	110	3.130.251.XXX	HK 17.251.39	182
1.330.200.XXX	Mk 16.20	110	3.130.251.XXX.056	HK 17.251.39.56	182
1.340.110.XXX	Mk 16.11	110	3.130.451.XXX	HK 17.451.39	182
1.340.210.XXX	Mk 16.21	110	3.160.111.XXX	HB 26.11	200
1.340.230.XXX	Mk 16.23	110	3.160.211.XXX	HB 26.21	200
162704 Set	Adapter front bezel, 72 x 36 mm	312	3.165.011.XXX	HB 26.01.3	200
1.650.910.XXX	K 66.91	85	3.200.101.XXX	HB 27.10	204
1.650.950.XXX	K 66.95	85	3.200.201.XXX	HB 27.20	204
1.660.200.XXX	K 67.20	85	3.205.001.XXX	HB 27.00.3	204
1.660.800.XXX	K 67.80	85	3.220.401.XXX	H 57	189
1.660.900.XXX	K 67.90	85	3.223.401.XXX	AH 57	189
1.660.910.XXX	K 67.91	85	3.240.201.XXX	H 37	185

Product overview
Basics

Pulse counters

Preset counters

Hour meters
Timers

Frequency displays
Tachometers

Position displays

Multifunction
devices

Energy meters

Process devices

Temperature
devices

Strain-gauge
controllers

Accessories
Index

List of order numbers

Order no.	Type / description	Page	Order no.	Type / description	Page	
3.241.201.XXX	H 37.1	185	6.52U.012.3X0	Codix 52U	250	Product overview Basics
3.242.201.XXX	H 37.2	185	6.531.012.300	Codix 531	288	Pulse counters
3.245.201.XXX	H 37.5	185	6.532.012.300	Codix 532	291	
3.300.211.XXX	HVa 15.21	213	6.533.012.300	Codix 533	280	Preset counters
3.300.311.XXX	HVa 15.31	213	6.534.012.300	Codix 534	270	
3.474.901.XXX	HR 47	196	6.540.012.XX0	Codix 540	72	Hour meters Timers
3.474.911.XXX	HR 47	196	6.541.01X.XX0	Codix 541	75	
3.550.401.XXX	HC 77	208	6.542.011.XX0	Codix 542	224	Frequency displays Tachometers
3.551.401.XXX	HC 77.55	208	6.542.012.XX0	Codix 542	224	
3.553.401.XXX	SHC 77	211	6.543.011.XX0	Codix 543	170	Position displays
3.553.401.XXX.060	SHC 77.60	211	6.543.012.XX0	Codix 543	170	
3.563.201.07X	HW 66	266	6.544.011.XX0	Codix 544	244	Multifunction devices
3.56M.201.075	HW 66 M	266	6.544.012.XX0	Codix 544	244	
3.802.11X	PMk 14.11	114	6.54P.012.XX0	Codix 54P	261	Energy meters
3.802.21X	PMk 14.21	114	6.54U.012.XX0	Codix 54U	258	
3.804.11X	PMk 16.11	114	6.560.010.XXX	Codix 560	134	Process devices
3.804.21X	PMk 16.21	114	6.564.010.X0X	Codix 564	294	
3.805.10X	PMk 18.10	114	6.565.010.X0X	Codix 565	272	Temperature devices
3.805.20X	PMk 18.20	114	6.566.010.X0X	Codix 566	300	
6.130.012.8XX	Codix 130	48	6.570.T1X.XXX	570T	235	Strain-gauge controllers
6.131.012.8XX	Codix 131	51	6.571.T1X.XXX	571T	247	
6.132.012.8X3	Codix 132	54	6.572.0116.XXX	572	139	Accessories Index
6.133.012.8XX	Codix 133	232	6.572.0118.XXX	572	139	
6.134.012.8XX	Codix 134	158	6.573.T1X.XXX	573T	276	
6.135.012.8XX	Codix 135	161	6.574.0116.DXX	574	227	
6.136.012.8XX	Codix 136	218	6.575.0116.XXX	575	142	
6.140.012.300.XXXX	Codix 140	57	6.575.0118.XXX	575	142	
6.141.012.300	Codix 141	164	6.901.010.8X0	901	120	
6.142.011.300.XXXX	Codix 142	57	6.907.010X.XA0	Codix 907	124	
6.143.011.300.XXXX	Codix 143	164	6.908.010X.XA0	Codix 908	124	
6.190.012.X00	190	78	6.923.01XX.XXX	Codix 923	127	
6.192.012.300	192	80	6.924.01XX.XXX	Codix 924	127	
6.194.012.X00	194	173	G003836	Enclosure blind, 48 x 24 mm [1.89 x 0.94"]	323	
6.198.012.300	198	175	G007501	Front bezel type F1B, beige	318	
6.520.012.3X0	Codix 520	60	G007502	Front bezel type F1B, black	318	
6.521.01X.3X0	Codix 521	63	G007503	Front bezel type F2B, beige	318	
6.522.011.3X0	Codix 522	221	G007504	Front bezel type F2B, black	318	
6.522.012.3X0	Codix 522	221	G008040	Base mount socket	324	
6.523.011.3X0	Codix 523	167	G008143	Transparent cover type 2 Dv, mounted on bezel	316	
6.523.012.3X0	Codix 523	167	G008153	Transparent cover type 2 Dvs, mounted on bezel	316	
6.524.011.3X0	Codix 524	240	G008300	Sealing cover type K1, transparent/grey	315	
6.524.012.3X0	Codix 524	240	G008301	Sealing cover type K1, transparent/black	315	
6.52C.012.3X0	Codix 52C	69	G008302	Sealing cover type K2, transparent/grey	315	
6.52P.012.3X0	Codix 52P	254	G008303	Sealing cover type K2, transparent/black	315	
6.52T.012.3X0	Codix 52T	66				

List of order numbers

Order no.	Type / description	Page
G008310	Sealing cover type KV3, transparent/grey	315
G008311	Sealing cover type KV3, transparent/black	315
G008433	Socket box type 926.1	320
G008434	Socket box type 945.2	319
G008439	Socket box type 946.1	320
G300000	DIN rail mount SR 1	322
G300001	DIN rail mount SR 2	322
G300002	DIN rail mount SR 3	322
G300003	Mounting frame with cut-out 50 x 50 mm [1.97 x 1.97"]	321
G300004	Mounting frame with cut-out 50 x 25 mm [1.97 x 0.98"]	321
G300005	Mounting frame with cut-out 92 x 45 mm [3.62 x 1.77"]	321
N003001	Adapter front bezel, 60 x 50 mm [2.36 x 1.97"], black	313
N003002	Transparent cover type 1 Dv, mounted on bezel	317
N510199	Mounting support	324
N510226	Adapter front bezel, ø 72 mm [2.83"], black	314
N511003	Gasket 60 x 75 mm [2.36 x 2.95"]	331
N511004	Gasket 58 x 58 mm [2.28 x 2.28"]	331
N511005	Gasket 60 x 50 mm [2.36 x 1.97"]	331
N511006	Gasket 58 x 33 mm [2.28 x 1.30"]	331
N511011	Gasket 39 x 40 mm [1.54 x 1.57"]	331
N511015	Gasket 53 x 28 mm [2.09 x 1.10"]	331
N511016	Gasket 72 x 72 mm [2.83 x 2.83"]	331
N511017	Gasket 55 x 55 mm [2.16 x 2.16"]	331
N511018	Gasket 48 x 48 mm [1.89 x 1.89"]	331
N511019	Gasket 60 x 50 mm [2.36 x 1.97"]	331
N511020	Gasket 60 x 75 mm [2.36 x 2.95"]	331
N511028	Gasket 48 x 48 mm [1.89 x 1.89"]	331
N511029	Gasket 48 x 24 mm [1.89 x 0.94"]	331
N511030	Gasket 55 x 31.5 mm [2.17 x 1.24"]	331
N511031	Gasket 96 x 49 mm [3.78 x 1.93"]	331
N511033	Gasket 49 x 49 mm [1.93 x 1.93"]	331
N511034	Gasket 49 x 25 mm [1.93 x 0.98"]	331
N511040	Gasket 36 x 24 mm [1.42 x 0.94"]	331
N511043	Gasket 55 x 26 mm [2.17 x 1.02"]	331
N511045	Gasket 50 x 25 mm [1.97 x 0.98"]	331
N511058	Gasket 32 x 15 mm [1.26 x 0.59"]	331
N511150	Gasket ø 71.1 mm [2.80"]	331
N511181	Gasket 96 x 48 mm [3.78 x 1.89"]	331
N511182	Gasket ø 58 mm [2.28"]	331
T005753	Enclosure blind, 53 x 28 mm [2.09 x 1.10"]	323
T008161	Adapter front bezel, 56 x 40 mm [2.20 x 1.57"], black	312
T008164	Adapter front bezel, 53 x 28 mm [2.09 x 1.10"], grey	312
T008165	Adapter front bezel, 53 x 28 mm [2.09 x 1.10"], black	312
T008170	Adapter front bezel, 55 x 55 mm [2.16 x 2.16"], grey	313
T008171	Adapter front bezel, 55 x 55 mm [2.16 x 2.16"], black	313

Order no.	Type / description	Page
T008176	Adapter front bezel, 72 x 72 mm [2.83 x 2.83"], grey	314
T008177	Adapter front bezel, 72 x 72 mm [2.83 x 2.83"], black	314
T008180	Adapter front bezel, 53 x 28 mm [2.09 x 1.10"], anthracite	312
T008181	Adapter front bezel, 56 x 40 mm [2.20 x 1.57"], anthracite	312
T008853	Adapter front bezel, 55 x 55 mm [2.16 x 2.16"], black	313
T008860	Adapter front bezel, 60 x 75 mm [2.36 x 2.95"], black	314
T008883	Adapter front bezel, 48 x 48 mm [1.89 x 1.89"], black	313
T009420	Adapter front bezel, 72 x 72 mm [2.83 x 2.83"], mating clip	314
T051687	Terminal cover type KA 37	324

Product overview
Basics

Pulse counters

Preset counters

Hour meters
Timers

Frequency displays
Tachometers

Position displays

Multifunction
devices

Energy meters

Process devices

Temperature
devices

Strain-gauge
controllers

Accessories
Index

Notes

Product overview Basics
Pulse counters
Preset counters
Hour meters Timers
Frequency displays Tachometers
Position displays
Multifunction devices
Energy meters
Process devices
Temperature devices
Strain-gauge controllers
Accessories Index

Kübler worldwide

Kübler Group

- 
Fritz Kübler GmbH
Germany
 Phone +49 7720 3903-0
info@kuebler.com
www.kuebler.com
- 
Fritz Kübler SARL
France
 Phone +33 3 89 53 45 45
info@kuebler-sarl.com
www.kuebler.fr
- 
Kübler Italia S.r.l.
Italy
 Phone +39 026 423 345
info@kuebler.it
www.kuebler.it
- 
Kübler Österreich
Austria
 Phone +43 720 510459
at@kuebler.com
www.kuebler.com
- 
Kubler SP. Z O.O.
Poland
 Phone +48 61 84 99 902
info@kubler.pl
www.kubler.pl
- 
Kübler Group
Spain
 Phone +34 91 1516773
alejandroperez-manrique@kuebler.com
www.kuebler.com
- 
Kübler Turkey Otomasyon Ticaret Ltd. Sti.
Turkey
 Phone +90 216 999 9791
cengizhan.temurcin@kuebler.com
www.kuebler.com.tr
- 
Kuebler (Beijing) Automation Trading Co. Ltd.
China
 Phone +86 10 8471 0818
beijing@kuebler.com
www.kuebler.com
- 
Kuebler Automation India Pvt. Ltd.
India
 Phone +91 2135 618200
 Fax +91 2135 618232
info@kuebler.in
www.kuebler.in
- 
Kuebler Korea (by F&B)
South Korea
 Phone +82 51 319 12 30
fnb@kuebler.co.kr
www.kuebler.kr
- 
Kuebler Inc.
USA
 Phone +1-704-705-4710
 Toll Free +1-855-KUEBLER (583-2537)
usa@kuebler.com
www.kuebler.com/usa

Europe

- Austria**
 FEK Österreich
 Deutsch Bieling 35
 A-7522 Heiligenbrunn
 Phone +43 720 510459
 Fax +43 720 510456
at@kuebler.com
www.kuebler.com
- Belarus**
 FEK Company
 Pushkin Ave., 29B
 BY-220015 Minsk
 Phone +375 17 202 68 00
 Fax +375 17 202 68 01
turck@fek.by
www.fek.by
- Belgium**
 Turck Multiprox N.V.
 Lion d'Orweg 12
 B-9300 Aalst
 Phone +32 53 76 65 66
 Fax +32 53 78 39 77
mail@multiprox.be
www.multiprox.be
- Bulgaria**
 Sensomat Ltd.
 Ul.Stratsin 4, vh.A, app.1
 P.O.B. 116
 BG-9300-Dobrich
 Phone +359-888 403 570
 Fax +359-58-603 033
info@sensomat.info
www.sensomat.info
- Croatia**
 Bering d.o.o.
 Ulica Pri rampi 2
 HR-49210 Zabok
 Phone +385 49 221 182
 Fax +385 49 223 658
bering@bering.hr
www.bering.hr
- Czech Republic**
 TURCK s.r.o.
 Na Brně 2065
 CZ-500 06 Hradec Králové
 Phone +420 - 4 95 51 87 66
 Fax +420 - 4 95 51 87 67
turck-cz@turck.com
www.turck.cz
- Denmark**
 Hans Følsgaard A/S
 Theilgaards Torv 1
 DK-4600 Køge
 Phone +45 43 20 86 00
 Fax +45 43 96 88 55
hf@hf.net
www.hf.net
- Estonia**
 Standel AS
 Kiisa 8
 EE-11313 Tallinn
 Phone +372 6 558 180
 Fax +372 6 558 179
standel@standel.ee
www.standel.ee
- Finland**
 Sähkölehto Oy
 Holkkitie 14
 FIN-00880 Helsinki
 Phone +358 9 774 6420
 Fax +358 9 759 1071
office@sahkolehto.fi
www.sahkolehto.fi
- France**
 Fritz Kübler S.à.r.l.
 Capteurs et codeurs industriels
 2 rue de Grande Bretagne
 F-68310 Wittelsheim
 Phone +33 3 89 53 45 45
 Fax +33 3 89 53 66 77
info@kuebler-sarl.com
www.kuebler.fr
- Germany**
 Fritz Kübler GmbH
 Schubertstrasse 47
 D-78054
 Villingen-Schwenningen
 Phone +49 7720 3903-0
 Fax +49 7720 21564
info@kuebler.com
www.kuebler.com
- Great Britain**
 OEM Automatic Ltd
 Whiteacres, Cambridge Road
 Whetstone
 GB-Leicester LE8 6ZG
 Phone +44 116 284 99 00
 Fax +44 116 284 17 21
information@uk.oem.se
www.oem.co.uk
- Greece**
 Industrial Automation Systems
 L.J. Skourgialos
 241, El. Venizelou Ave.
 GR-176 73 Kallithea - Athens
 Phone +30 210 9510260
 Fax +30 210 9511048
info@ias.gr
www.ias.gr
- Hungary**
 Kvalix Automatika Kft.
 Kiss Ernő u. 1-3
 H-1046 Budapest
 Phone +36 1 272 2242
 Fax +36 1 272 2244
info@kvalix.hu
www.kvalix.hu
- Iceland**
 Reykjavell Ltd.
 Skipholt 35
 IS-125 Reykjavik
 Phone +354 5 88 60 00
 Fax +354 5 88 60 88
reykjavell@reykjavell.is
www.reykjavell.is
- Ireland**
 Kübler Group
 Fritz Kübler GmbH
 Schubertstr. 47
 D-78054
 Villingen-Schwenningen
 Phone +49 7720 3903-0
 Fax +49 7720 21564
info@kuebler.com
www.kuebler.com
- Italy**
 • Encoders:
 Kübler Italia Srl.
 Viale Sarca, 96
 I-20125 Milano MI
 Phone +39 026 423 345
 Fax +39 026 611 3843
info@kuebler.it
www.kuebler.it
 • Counters and process devices:
 MAS AUTOMAZIONE S.R.L.
 Via G. Galilei 20
 I-20090 Segrate (MI)
 Phone +39 02 26 92 20 90
 Fax +39 02 26 92 16 87
info@masautomazione.it
www.masautomazione.it
- Lithuania**
 UAB FEK Elektronika
 Naugarduko 91-415
 LT-03160, Vilnius, Lietuva
 Phone +370 700 01760
 Phone +3705 2133603
 Fax +3705 2159198
info@fek.lt
www.fek.lt
- Netherlands**
 Duranmatic B.V.
 Robijn 800
 NL-3316 KE Dordrecht
 Phone +31 78 631 05 99
 Fax +31 78 613 11 33
info@duranmatic.nl
www.duranmatic.nl
- Norway**
 ELTECO AS
 Floodmyrveien 24
 N-3946 Porsgrunn
 Phone +47 35 56 20 70
 Fax +47 35 56 20 99
firmapost@elteco.no
www.elteco.no
- Poland**
 Kubler Sp. z o.o.
 ul. Dabrowskiego 441
 PL-60-451 Poznan
 Phone +48 61 849 99 02
 Fax +48 61 849 99 03
info@kubler.pl
www.kubler.pl
 ASTAT sp. z o.o.
 ul. Dabrowskiego 441
 PL-60-451 Poznan
 Phone +48 61 848 8871
 Fax +48 61 848 8276
info@astat.com.pl
www.astat.com.pl
 • Electronic counters and process displays:
 IMPOL-1 Sp.J.
 ul. Krakowiaków 103
 PL-02-255 Warszawa
 Phone +48 22 886 56 02
 Fax +48 22 886 56 04
biuro@impol-1.pl
www.impol-1.pl
 • Encoders:
 OEM AUTOMATIC Sp. z o.o.
 ul. Działkowa 121 A
 PL-02-234 Warszawa
 Phone +48 22 863 27 22
 Fax +48 22 863 27 24
info@pl.oem.se
www.oemautomatic.pl
- Portugal**
 Kübler Group
 C/ Aviación Española 5, 4 D
 28003 Madrid, Spain
 Phone +34 91 1516773
 Mobil +34 630 976 107
alejandroperez-manrique@kuebler.com
www.kuebler.com
 vLA2P – Tecnologias de Auto-
 mação, LDA
 Rua Teófilo Braga, 156 A
 Escrit. F - Edifício S. Domingos
 Cabeço do Moura
 PT-2785-122 S. Domingos de Rana
 Phone +351 21 444 70 70
 Fax +351 21 444 70 75
la2p@la2p.pt
www.la2p.pt
- Russia**
 LLC Servotechnica
 Klara Tsetkin str., 33/35
 RUS-125130 Moscow
 Phone +7 495 797 8866
 Fax +7 495 450 0043
info@servotechnica.ru
www.servotechnica.ru
- Slovakia**
 S.D.A. s. r. o.
 Jána Bottu 4
 SK-974 01 Banská Bystrica
 Phone +421 48 472 34 11
 Fax +421 48 472 343 69
sekretariat@s-d-a.sk
www.s-d-a.sk
- Slovenia**
 Balluff d.o.o.
 Livadna ulica 1
 SLO-2204
 Miklavž na Dravskem polju
 Phone +386 2 6 29 03 00
 Fax +386 2 6 29 03 02
senzorji.sb@siol.net
www.senzorji-sb.si
- Spain**
 Kübler Group
 C/ Aviación Española 5, 4 D
 28003 Madrid
 Phone +34 91 1516773
 Mobil +34 630 976 107
alejandroperez-manrique@kuebler.com
www.kuebler.com
 Elion, S.A.
 Farell, 5
 E-08014 Barcelona
 Phone +34 93 298 20 00
 Fax +34 93 431 18 00
elion@elion.es
www.elion.es
- Sweden**
 OEM AUTOMATIC AB
 Dalagatan 4, Box 1011
 S-57328 Tranås
 Phone +46 75-242 4100
 Fax +46 75-242 4119
info@aut.oem.se
www.oemautomatic.se
- Switzerland**
 Fritz Kübler S.à.r.l.
 2 rue de Grande Bretagne
 F-68310 Wittelsheim
 Phone +33 3 89 53 45 45
 Fax +33 3 89 53 66 77
info@kuebler-sarl.com
www.kuebler.fr
 ① Kübler Italia Srl.
 Viale Sarca, 96
 I-20125 Milano MI
 Phone +39 026 423 345
 Fax +39 026 611 3843
info@kuebler.it
www.kuebler.it
 ② Fritz Kübler GmbH
 Schubertstraße 47
 D-78054 Villingen-Schwenningen
 Phone +49 7720 3903-0
 Fax +49 7720 21564
info@kuebler.com
www.kuebler.com
- Turkey**
 Kübler Turkey Otomasyon
 Ticaret Ltd. Sti.
 Bahçelievler Mah.
 Serpinti Sok.No:6 Kat:4
 TR - 34893 Pendik/Istanbul
 Phone +90 216 999 9791
 Fax +90 216 999 9784
cengizhan.temurcin@kuebler.com
www.kuebler.com
 • System Integrator
 ROBOSAN Otomasyon San.Tic. Ltd.
 Robosan Plaza Bahçelievler Mah.
 Serpinti Sok. No:6 Pendik
 TR-34893 Pendik/Istanbul
 Phone +90 216 340 39 70
 Fax +90 216 340 39 64
info@robosan.com.tr
www.robosan.com.tr
 • Encoders, process devices and transmission technology:
 Sanil Teknik
 Elektrik San. ve Tic. Ltd. Sti.
 Okçumusa Caddesi
 Tusak Sokak
 No: 27/5 Karaköy
 TR-34420 Istanbul
 Phone +90 212 256 94 28
 Fax +90 212 256 94 04
sanil@sanil.com.tr
www.sanil.com.tr
 • Counters:
 ERUZ Elektrik San. ve Tic. A.S.
 Necatibey Caddesi
 Sait Demirbaş Han No.5 K.1
 TR-34425 Istanbul
 Phone +90 212 2 93 60 36
 Fax +90 212 2 44 51 56
eruzelektrik@eruzelektrik.com.tr
www.eruzelektrik.com.tr

America, Asia, Australia, Africa

Catalog distributors: (Europe)

Austria
Farnell GmbH
Birkenstrasse 2
A-5300 Salzburg/Hallwang
Phone +43 662 - 218 06 80
Fax +43 662 - 218 06 70
verkauf.at@farnell.com
www.farnell.at

RS Components
Albrechtser Straße 11
A-3950 Gmünd
Phone +43 28 52 505
Fax +43 28 52 53 223
www.rs-components.at

France
RS Components SAS
Rue Norman King BP 40453
F-60031 Beauvais CEDEX
Phone +33 3 44 10 16 48
Fax +33 3 44 10 16 44
www.radiospares.fr

Farnell France SAS
81-83 rue Henri Depagneux
BP 60426 Limas
F-69654 Villefranche sur
Saône
Cedex
Phone +33 4 74 68 99 99
Fax +33 4 74 68 99 90
ventes@farnell.com
www.farnell.fr

Great Britain
RS Components Ltd.
PO Box 99, Corby
GB-Northants NN17 9RS
Phone +44 84 58 50 99 00
Fax +44 15 36 40 56 78
www.rs-components.com

Farnell
Canal Road
GB-Leeds, LS12 2TU
Phone +44 8447 11 11 11
Fax +44 8447 11 11 13
sales@farnell.co.uk
www.farnell.co.uk

Italy
RS Components S.p.A.
Via De Vizzi 93/95
I-20092, Cinisello Balsamo,
Milano
Phone +39 02 660 581
Fax +39 02 660 580 51
www.rs-components.it

Distrelec Italia s.r.l.
Via Canova 40/42
I-20020 Lainate (Mi)
Phone +39 02 - 93 75 51
Fax +39 02 - 93 75 57 55
info-it@distrelec.com
www.distrelec.com

Switzerland
Distrelec AG
Grabenstraße 6
CH-8606 Nänikon
Phone +41- 44 9 44 99 11
Fax +41- 44 9 44 99 88
www.distrelec.com

Farnell AG
Brandschenkestr. 178
Postfach 1703
CH-8027 Zürich
Phone +41 1 - 204 64 64
Fax +41 1 - 204 64 54
verkauf.ch@farnell.com
www.farnell.ch

Argentina
AUMECON S.A.
Acassuso 4768
1605 Munro
Prov. de Buenos Aires
Phone +54 11 47 56 1251
Fax +54 11 47 62 63 31
ventas@aumecon.com.ar
www.aumecon.com.ar

Australia
Balluff PTY LTD
18 Malvern Street
Bayswater, VIC 3153
Phone +61 1300 225833
Fax +61 1300 653894
sales@balluff.com.au
www.balluff.com.au

Brazil
Brastronic Comércio e
Serviço Importação e
Exportação Ltda.
Representante Exclusivo
no Brasil
Rua Antônio Pagano,
43 - Jardim Prudência
Cep 04368-040 São Paulo
Phone +55 (11) 5670-8970
vendas@kebrasil.com.br
www.kebrasil.com.br

Canada
Turck Chartwell Canada Inc.
140 Duffield Drive
Markham, Ontario L6G 1B5
Phone +1 905 513 7100
Fax +1 905 513 7101
sales@www.chartwell.ca
www.chartwell.ca

China
Kuebler (Beijing) Automation
Trading Co. Ltd.
Rm 1603, B Area, Tower 2,
Wangjing Soho,
No.1 Futong East Street,
Chaoyang, Beijing,
China,100102
Phone +86 10 8471 0818
Fax: +86 10 8471 0819
beijing@kuebler.com
www.kuebler.com

Egypt
AEE Advanced Electronic
Engineering Co.
14 Gamal EL Din Aly Khairy St.,
AL Nozha AL Gadida
Heliopolis, Cairo
Tel. +202 26229472
Fax +202 26229473
sales.dep@aeecontrols.com
www.aeecontrols.com

Hong Kong
Po Kwong Electric (HK) Ltd.
Rm. 177-180, 1/F, Blk C,
Hang Wai Ind. Ctr.,
6 Kin Tai St., Tuen Mun, N.T
Phone +852 24 23 66 22
Fax +852 24 61 10 02
sales@pokwong.com
www.pokwong.com

India
Kuebler Automation India Pvt Ltd
Plot No 677, S. No. 269/3,
Paud Road, Bhugaon,
Pune 412 115,
Maharashtra
Phone +91 99 7065 5599
Phone +91 20 6790 1-200 / 230 /
214 / 202
Fax +91 20 6790 1232
info@kuebler.in
www.kuebler.in

Indonesia
PT. Supra Engineering
Jl. Pecenongan 17 D
RI-10120 Jakarta
Phone +62 21 345 73 55
Fax +62 21 345 73 18
atsupra@supra.co.id
www.supra-engineering.com

Israel
Omega Engineering
P.o.Box 190
Ein Carmel 30860
Phone +972-4-9544993
Fax +972-4-9544992
info@omegae.net
www.omegae.net

Lebanon
Industrial Technologies S.A.L
(ITEC)
Blvd. Fouad Chehab
Point Center, Sin El Fil, Beirut
Phone +961 (1) 491161
Phone +961 (1) 491162
info@iteclb.com
www.iteclb.com

Malaysia
dpstar Smart Solutions Sdn Bhd
No. 37-1, Jalan OP 1/2
Pusat Perdagangan One Puchong,
Off Jalan Puchong,
47160 Puchong,
Selangor Darul Ehsan,
Malaysia
Phone +603 8074 8866
Fax +603 8074 8666
christiau@dpstar.com.my
www.dpstar.com.my

Mexico
TURCK Comercial, S. de RL de CV
Blvd. Campestre No. 100
Parque Industrial SERVER
C.P. 25350 Arteaga, Coahuila
Phone +52 844 411 6650
Toll Free: 01-800-01-TURCK
(Mexico only)
Fax +52 844 482 6926
mexico@turck.com
www.turck.com.mx

Morocco
r2i Consult SARL
109 rue Montaigne Val
Fleuri Maarif Casablanca
Maroc
Phone +212522986960
Fax +212522989537
info@r2imaroc.ma
www.r2imaroc.com

New Zealand
Carrel-Electrade Ltd.
P.O. Box 11-078
Eilerslie
NZ-Auckland 1542
Phone +64 95251753
Fax +64 95251756
sales@carrel-electrade.co.nz
www.carrel-electrade.co.nz

Peru
Techpro SAC
Calle Alberto del Campo 414
Magdalena del Mar
Lima 17 - Peru
Phone +51 98943 58-54
Fax +51 17272 685
techpro.peru@techprocorp.net
www.techprocorp.net

Philippines
Technorand Sales Coporation
122 McArthur Highway
0 Malabon, Metro Manila
Phone +632 985 07 05
Fax +632 716 59 86
technorand@gmail.com

Singapore
Raymond International Pte. Ltd.
Blk 219 Henderson Road #07-04
Henderson Industrial Park
Singapore 159556
Phone +65 62 76 37 38
Fax +65 62 76 37 39
sales@raymondcom.com
www.raymondcom.com

South Africa
Kübler Group
DC Auto-Motion (Pty) Ltd.
11 Sunrock Close,
131 Sunnyrock, Ext. 2
Germiston, Gauteng.
Phone +27 11 453 1740
Fax +27 86 508 5929
dave@dcauto-motion.co.za
www.kuebler.co.za

South Korea
Kuebler Korea (by F&B)
578, Kwaebop-dong, Sasang-ku
Pusan Industrial Supplies
Market 9-116
PUSAN
Phone +82 51 319 12 30
Fax +82 51 319 12 50
fnb@kuebler.co.kr
www.kuebler.kr

Taiwan, R.O.C.
• Encoders, transmission
technology:
E-E-Sensors & Automation Int'l Corp.
No.17-2, Beichang 2nd St.
Fengshan Dist.,
Kaohsiung City 83053
Taiwan, R.O.C.
Phone +886-7-7323606
Fax +886-7-7333023
ez-corp@umail.hinet.net
www.e-sensors.com.tw

• Electronic counters and
process devices:
Canaan Electric Corp.
6F-5, No. 63, Sec. 2
Chang An East Road
Taipei
Phone +886 225 08 23 31
Fax +886 225 08 47 44
sales@canaan-elec.com.tw
www.canaan-elec.com.tw

Thailand
Technology Instruments Co., Ltd.
549/9 Onnut Road Kwaeng
Pravet, Khet Pravet
Bangkok 10250
Phone +662 74 388 88
Fax +662 74 388 43
marketing@tic.co.th
www.tic.co.th

Tunisia
H2M Technologies
13, Rue El Moutanabi
TN-2037 El Menzah 7 - Tunis
Phone +216 71 42 76 77
Fax +216 71 42 76 88
h2m.tech@planet.tn

U.S.A.
Kuebler Inc.
10430-J Harris Oak Boulevard
Charlotte, NC 28269
Phone +1-704-705-4710
Toll Free +1-855-KUEBLER (583-2537)
Fax +1-704-733-9170
usa@kuebler.com
www.kuebler.com/usa

• Counting and process
technology:
Howland Technology
8129 North Austin AVE
Morton Grove, IL 60053
Toll-free number:
1-800-951-8774
Phone 847 965 9808
Fax 847 901 9846
sales@howlandtechnology.com
www.kueblerusa.com

United Arab Emirates
Baer Measurements LLC
P.O. Box 111393
Al Gaith Tower 1902,
Hamdan Street
Abu Dhabi - UAE
Phone +971 2 627 2097
Fax +971 2 627 2091
info@bml.ae
www.bml-international.com

Vietnam
GNN Co., Ltd
153, Nguyen Van Thu
Da Koa Ward, District 1
Ho Chi Minh City
Phone +84 8 3517 4923
Fax +84 8 3517 4924
contact@gnnvietnam.com
www.gnnvietnam.com

Product overview
Basics
Pulse counters
Preset counters
Hour meters
Timers
Frequency displays
Tachometers
Position displays
Multifunction
devices
Energy meters
Process devices
Temperature
devices
Strain-gauge
controllers
Accessories
Index

Contact partners in Germany

PLZ 01000 ... 09999
PLZ 15000 ... 15999
 Kübler Vertriebsbüro Süd-Ost
 Lars Meyer
 Durchfahrt 9
 09569 Oederan
 Phone +49 37292 283500
 Fax +49 37292 283501
 lars.meyer@kuebler.com

PLZ 10000 ... 14999
PLZ 16000 ... 19999
PLZ 20000 ... 32999
PLZ 38000 ... 39999
 Kübler Vertriebsbüro Nord
 Hermi Herrmann
 Mohndblumenweg 6
 28876 Oyten
 Phone +49 4207 6880-32
 Fax +49 4207 6880-34
 hermi.herrmann@kuebler.com

PLZ 33000 ... 33999
 Kübler Vertriebsbüro West
 Torsten Czubkowski
 Auf der Ümcke 11 a
 59757 Arnsberg
 Phone +49 2932 891898
 Fax +49 2932 53311
 torsten.czubkowski@kuebler.com

PLZ 34000 ... 37999
 Kübler Vertriebsbüro Mitte
 Stefan Heinigk
 Gartenstraße 10
 35759 Driedorf
 Phone +49 2775 578427
 Fax +49 2775 578428
 stefan.heinigk@kuebler.com

PLZ 40000 ... 47999
 Kübler Vertriebsbüro West
 Torsten Czubkowski
 Auf der Ümcke 11a
 59757 Arnsberg
 Phone +49 2932 891898
 Fax +49 2932 53311
 torsten.czubkowski@kuebler.com

PLZ 48000 ... 49999
 Kübler Vertriebsbüro Nord
 Hermi Herrmann
 Mohndblumenweg 6
 28876 Oyten
 Phone +49 4207 6880-32
 Fax +49 4207 6880-34
 hermi.herrmann@kuebler.com

PLZ 50000 ... 54999
PLZ 55300 ... 55999
PLZ 56500 ... 56999
PLZ 58000 ... 59999
 Kübler Vertriebsbüro West
 Torsten Czubkowski
 Auf der Ümcke 11a
 59757 Arnsberg
 Phone +49 2932 891898
 Fax +49 2932 53311
 torsten.czubkowski@kuebler.com

PLZ 55000 ... 55299
PLZ 56000 ... 56499
PLZ 57000 ... 57999
 Kübler Vertriebsbüro Mitte
 Stefan Heinigk
 Gartenstraße 10
 35759 Driedorf
 Phone +49 2775 578427
 Fax +49 2775 578428
 stefan.heinigk@kuebler.com

PLZ 60000 ... 65999
PLZ 67000 ... 67599
PLZ 68000 ... 69999
 Kübler Vertriebsbüro Mitte
 Stefan Heinigk
 Gartenstraße 10
 35759 Driedorf
 Phone +49 2775 578427
 Fax +49 2775 578428
 stefan.heinigk@kuebler.com

PLZ 66000 ... 66999
PLZ 67600 ... 67999
 Kübler Vertriebsbüro West
 Torsten Czubkowski
 Auf der Ümcke 11a
 59757 Arnsberg
 Phone +49 2932 891898
 Fax +49 2932 53311
 torsten.czubkowski@kuebler.com

PLZ 70000 ... 79999
 Kübler Vertriebsbüro Süd-West
 Michael Schwarz
 Im Lug 36
 74360 Ilsfeld
 Phone +49 7133 2294895
 Fax +49 7133 2294896
 michael.schwarz@kuebler.com

PLZ 80000 ... 83999
PLZ 87000 ... 87999
PLZ 89200 ... 89499
 Kübler Vertriebsbüro Süd
 Schubertstraße 47
 78054 VS-Schwenningen
 Phone +49 7720 3903-0
 Fax +49 7720 21564
 info@kuebler.com

PLZ 84000 ... 86999
 Kübler Vertriebsbüro Süd-Ost
 Lars Meyer
 Durchfahrt 9
 09569 Oederan
 Phone +49 37292 283500
 Fax +49 37292 283501
 lars.meyer@kuebler.com

PLZ 88000 ... 89199
PLZ 89500 ... 89999
 Kübler Vertriebsbüro Süd-West
 Michael Schwarz
 Im Lug 36
 74360 Ilsfeld
 Phone +49 7133 2294895
 Fax +49 7133 2294896
 michael.schwarz@kuebler.com

PLZ 90000 ... 95999
 Kübler Vertriebsbüro Süd-Ost
 Lars Meyer
 Durchfahrt 9
 09569 Oederan
 Phone +49 37292 283500
 Fax +49 37292 283501
 lars.meyer@kuebler.com

PLZ 96000 ... 99999
 Kübler Vertriebsbüro Mitte
 Stefan Heinigk
 Gartenstraße 10
 35759 Driedorf
 Phone +49 2775 578427
 Fax +49 2775 578428
 stefan.heinigk@kuebler.com

Approved system partners/ distributors

22149 Hamburg
 Hermann Seidel GmbH
 Techn. Vertretungen
 Rahlstedter Str. 16
 Phone +49 40 675085-0
 Fax +49 40 675085-85
 info@seidel-gmbh.de
 www.seidel-gmbh.de

42499 Hückeswagen
 Fuhrmeister + Co. GmbH
 Industrie-Elektronik
 Stahlschmidtsbrücke 61
 Phone +49 2192 851122
 Fax +49 2192 851127
 info@fuhrmeister-gmbh.de
 www.fuhrmeister-gmbh.de

66287 Göttelborn
 Herbert Neundörfer
 GmbH & Co. KG
 Werksvertretungen
 Am Campus 5
 Phone +49 6825 9545-0
 Fax +49 6825 9545-99
 info@herbert-neundoerfer.de
 www.herbert-neundoerfer.de

82069 Hohenschäftlarn
 Bachmann
 Electronic GmbH
 Am Wagnerfeld 4
 Phone +49 8178-8676-0
 Fax +49 8178-8676-50
 info@bachmann-electronic.de
 www.bachmann-electronic.de

Catalogue distributors (Germany):

28359 Bremen
 Distrelec Schuricht GmbH
 Lise Meitner-Str. 4
 Phone +49 1805 2234-35
 Fax +49 1805 2234-36
 scc@distrelec.de
 www.distrelec.de

64546 Mörfelden-Walldorf
 RS Components GmbH
 Hessenring 13 b
 Phone +49 6105 401234
 Fax +49 6105 401100
 www.rs-components.de

82041 Oberhaching
 Farnell GmbH
 Keltenring 14
 Phone +49 89 61393939
 www.farnell.de

92240 Hirschau
 Conrad Electronic SE
 Klaus-Conrad-Straße 1
 92240 Hirschau
 Phone +49 9604 408 787
 www.conrad.com

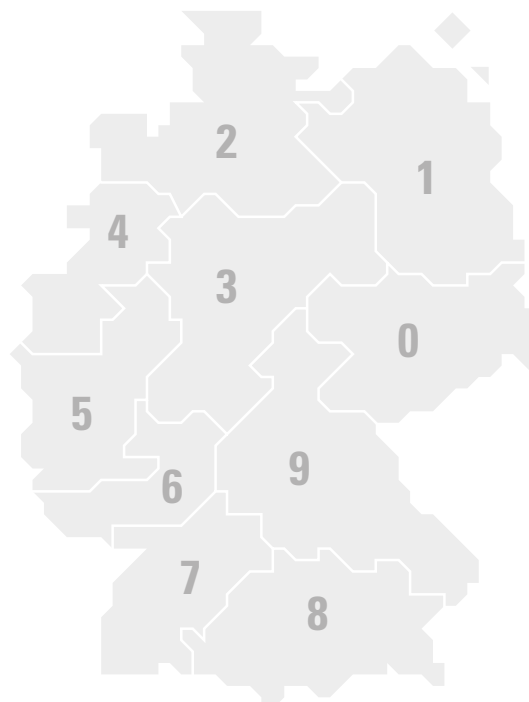

Kübler worldwide

The Kübler Group is a worldwide leading and strongly growing family-run company with four production sites, eleven subsidiaries and strong agents in more than 50 countries.

Kübler always focuses on understanding the application of the customer. This results in suitable products and solutions. So trust in a technically well-founded advice and benefit from a lasting application support. Over 480 persons are working all over the world for Kübler and pursue one goal: inspire their customers!



Europe

Austria
Belarus
Belgium
Bulgaria
Croatia
Czech Republic
Denmark
Estonia
Finland
France
Germany
Great Britain
Greece
Hungary
Iceland
Ireland

Lithuania
Italy
Netherlands
Norway
Poland
Portugal
Russia
Slovakia
Slovenia
Spain
Sweden
Switzerland
Turkey
Ukraine

Africa

Egypt
Morocco
South Africa
Tunisia

North and South America

Argentina
Brazil
Canada
Mexico
Peru
U.S.A.

Oceania

Australia
New Zealand

Asia

China
Hong Kong
India
Indonesia
Israel
Lebanon
Malaysia
Philippines
Singapore
South Korea
Taiwan, R.O.C
Thailand
United Arab Emirates
Vietnam

Kübler Group
Fritz Kübler GmbH
Schubertstrasse 47
D-78054 Villingen-Schwenningen
Germany
Phone +49 7720 3903-0
Fax +49 7720 21564
info@kuebler.com
www.kuebler.com

www.kuebler.com/counters
www.kuebler.com/process_devices