

Overview

The new AMOT XT is the most advanced butterfly-style positive air shut off valve on the market today. Engineered with the latest technology and loaded with enhanced features, this valve shuts down a runaway diesel by positively choking off engine intake air. The valve operates as part of a fully-automatic overspeed shutdown system when paired with our Revguard 2 speed switch and activation kit.

The XT range currently offers 12V or 24V electric actuation of the solenoid to rapidly close the valve's butterfly disc which shuts off intake air flow into the engine. The XT range is available in a variety of sizes to fit your specific applications.

It is manufactured from corrosion resistant, RoHS compliant materials that offer toughness under extreme temperatures and resistance to corrosive environments.

New Enhanced Features

- Temperature range tolerance of -40°C to 125°C
- Tested to rigorous engine OEM standards for:
 - resistance to shock
 - corrosion
 - vibration
 - life cycle
 - Ingress Protection ratings IP69k and IP67
- Optional integrated valve position switch
- Field-serviceable components limit downtime

The butterfly valve most trusted
by engine manufacturers



Dimensions

Side View

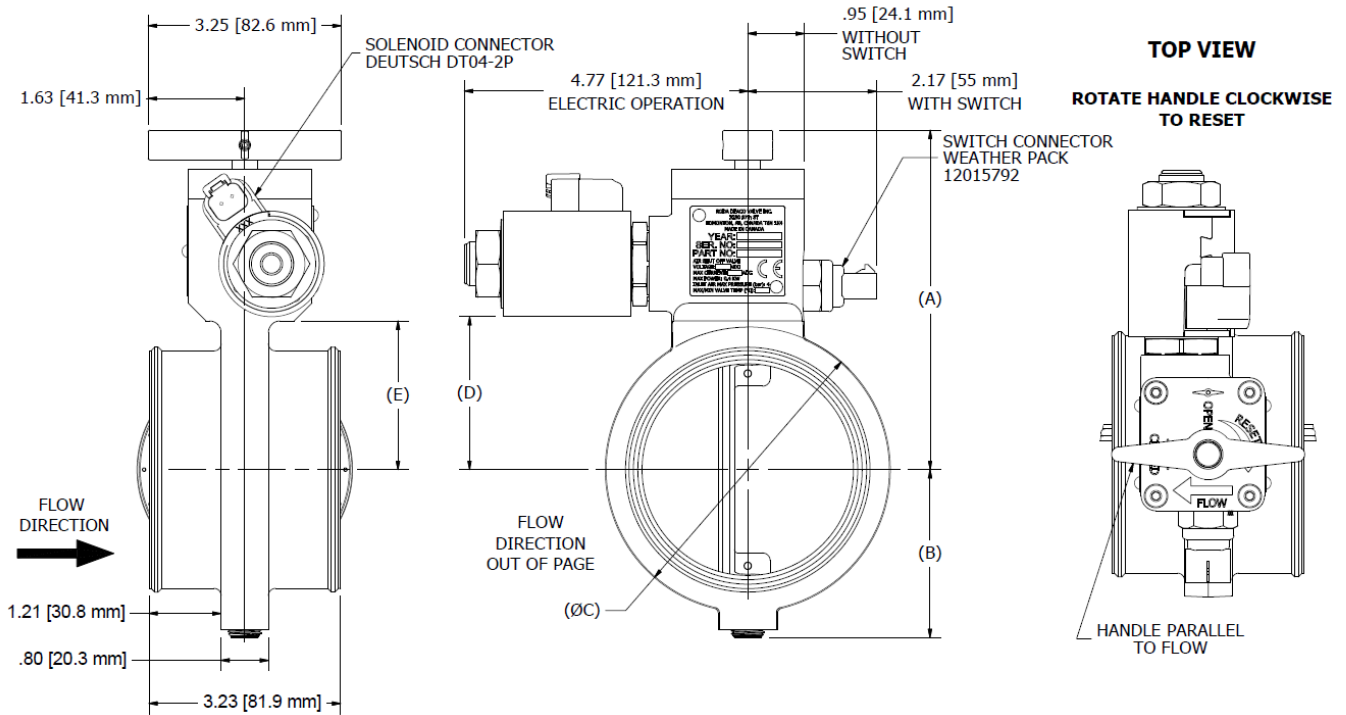

VALVE DIMENSIONS						
OD (in)	A (in)	B (in)	C (in)	D (in)	E (in)	Weight (lb)
3.5	5.46	2.58	4.30	2.32	2.25	4.0
4.0	5.71	2.83	4.80	2.57	2.50	4.1
5.0	6.21	3.33	5.80	3.07	3.00	4.5

VALVE DIMENSIONS						
OD (in)	A (in)	B (in)	C (in)	D (in)	E (in)	Weight (lb)
5.5	6.71	3.48	6.30	3.32	3.25	5.4
6.0	6.96	3.73	6.80	3.57	3.50	5.6
7.0	7.46	4.23	7.80	4.07	4.0	6.2
8.0	7.96	4.73	8.80	4.57	4.50	6.8

Mating Solenoid and Switch Connectors

Included with Valve (comes with 12-inch pigtail)

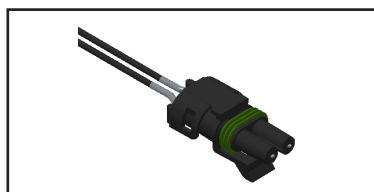

XT switch connector (RKS-Xt-017)

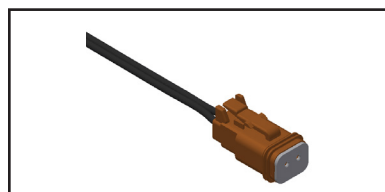

XT solenoid connector (RKS-Xt-016)

Specifications

Standard Materials		Valve body/disc	Anodized aluminum
		Seals	Viton
		Solenoid housing	Plated steel
Intake & Ambient Air Temp	Electric	Minimum: -40°C / maximum: 125°C	
Max Charge Air Pressure		5 bar (72 psi); Solenoid coil duty cycle: 60s max on/540s off (11%)	
Electric Solenoid	12 VDC	26.4 Amps (max) @ 13.2 VDC / -40°C	
		19.8 Amps (max) @ 13.2 VDC / 25°C	
	24 VDC	13.2 Amps (max) @ 26.4 VDC / -40°C	
		9.9 Amps (max) @ 26.4 VDC / 25°C	
Switch Rating		4.4 Amps DC max, 100°C max temperature rating. Please contact factory for higher temperature requirements.	

Product Code Definitions

Example	XT	3	5	B	2	A	3.5" OD, 24V, low temp, no switch
---------	----	---	---	---	---	---	-----------------------------------

Basic model code	XT								
							mm OD	inches OD	
Valve flange size		3	5				89	3.5	
		4	0				102	4.0	
		5	0				127	5.0	
		5	5				140	5.5	
		6	0				152	6.0	
		7	0				178	7.0	
		8	0				203	8.0	
Actuator				A			Electric power to close - 12 VDC		
				B			Electric power to close - 24 VDC		
Temperature (Disc Seal)					2		Low temp (-40°C to +125°C)		
Switch type				A			No switch		
				B			Valve open = switch open		
				C			Valve open = switch closed		
				D			Valve open = switch open (heavy duty) available on 6", 7", 8"		
				E			Valve open = switch closed (heavy duty) available on 6", 7", 8"		

Note: Switch E option has 33 kΩ internal shunt resistor.

Service Schedule

Valve servicing should be conducted according to the maintenance schedule in the table below. However, frequency of part replacement may vary depending on environmental and operational factors. Contact customer service for specific kit ordering information.

Engine Hours on Valve	Switch	Actuation	Replace Valve
10,000	✓	✓	
20,000			✓

Service Kits

Part No.	Description
RKS-XT-001	12V complete solenoid kit (A Actuator Code)
RKS-XT-002	24V complete solenoid kit (B Actuator Code)
RKS-XT-018	12V solenoid coil kit (A Actuator Code)
RKS-XT-019	24V solenoid coil kit (B Actuator Code)
RKS-XT-006	Switch kit: valve open = switch open (B Switch Code)
RKS-XT-007	Switch kit: valve open = switch closed (C Switch Code)
RKS-XT-024	Switch kit: valve open = switch open (D switch code)
RKS-XT-025	Switch kit: valve open = switch closed (E switch code)

Accessories for Fully Automatic Systems

Activation Kits	
Part No.	Description
1520-001	Revguard 2 speed switch kit
AK2-E1-RM	Electric activation kit for 12V valve
AK2-E2-RM	Electric activation kit for 24V valve

Hose and Clamp Kits	
Part No.	Description
IK-3500H-01	Hose and clamp kit for 3.5 in (89 mm)
IK-4000H-01	Hose and clamp kit for 4.0 in (102 mm)
IK-5000H-01	Hose and clamp kit for 5.0 in (127 mm)
IK-5500H-01	Hose and clamp kit for 5.5 in (140 mm)
IK-6000H-01	Hose and clamp kit for 6.0 in (152 mm)
IK-7000H-01	Hose and clamp kit for 7.0 in (178 mm)



Revguard speed switch (1520-001)

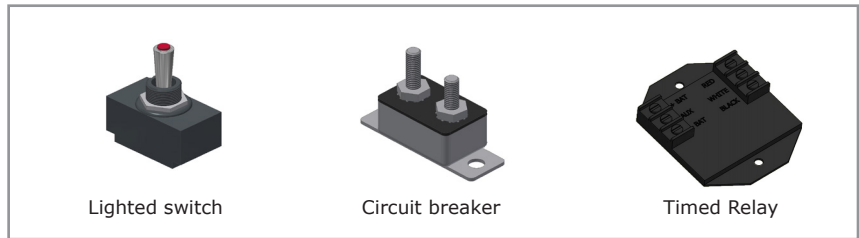

Activation kit components



Hose and clamp kit (IK-3500H-01)

WARNING

These products can expose you to chemicals including carbon black (airborne and extracts), antimony trioxide, titanium dioxide, silica (crystalline), di(2-ethylhexyl)phthalate, ethylene thiourea, acrylonitrile, 1,3-butadiene, epichlorohydrin, toluenediisocyanate, tetrafluoroethylene, ethylbenzene, formaldehyde, furfuryl alcohol, glass fibers, methyl isobutyl ketone, nickel (metallic and compounds), lead and lead compounds which are known to the state of California to cause cancer; and 1,3 butadiene, epichlorohydrin, di(2-ethylhexyl)phthalate, di-isodecyl phthalate, ethylene thiourea, methyl isobutyl ketone, toluene, lead and lead compounds which are known to the state of California to cause birth defects and other reproductive harm. For more information go to www.P65Warnings.ca.gov.

Americas

AMOT - USA
 Tel +1 (281) 940 1800
 Fax +1 (713) 559 9419
 customer.service@amot.com

AMOT - Canada
 Tel +1 (780) 465 4429
 Fax +1 (780) 469 6275
 customer.service@amot.com

Asia Pacific

AMOT - China
 Tel +86 21 5910 4052
 Fax +86 21 5237 8560
 shanghai@amot.com

Europe, Middle East and Africa

AMOT - United Kingdom
 Tel +44 (0) 1284 715739
 Fax +44 (0) 1284 760256
 info@amot.com

AMOT - Germany
 Tel +49 (0) 40 8537 1298
 Fax +49 (0) 40 8537 1331
 germany@amot.com